

Instruction
booklet

Gas hob

ZGF 642
ZGF 692 C
ZGF 692 CT

Welcome to the world of Electrolux

Thank you for choosing a first class product from Electrolux, which hopefully will provide you with lots of pleasure in the future.

The Electrolux ambition is to offer a wide variety of quality products that make your life more comfortable.

You find some examples on the cover in this manual. Please take a few minutes to study this manual so that you can take advantage of the benefits of your new machine.

We promise that it will provide a superior User Experience delivering Ease-of-Mind.

Good luck!

Contents

Important Safety Information	4
Description of the Hobs	6
Instructions for the User	7
Operation	8
Maintenance and Cleaning	10
Something Not Working?	12
Guarantee/Customer Service	28
European Guarantee	30
Instructions for the Installer	13
Engineer technical data	13
Important safety requirements	15
Installation	16
Gas Connection	17
Location	18
Fitting the Hob into the Worktop	19
Building In	20
Building over a cupboard or drawer	20
Building over a kitchen unit with door	20
Electrical Connections	21
Wiring diagram	22
Fault Finding	23
Commissioning	26
Conversion from Natural Gas to LPG	27

Guide to Use the instructions

The following symbols will be found in the text to guide you throughout the Instructions:



Safety Instructions



Step by step instructions for an operation



Hints and Tips



Environmental information

MANUFACTURER:

ELECTROLUX HOME PRODUCTS ITALY S.P.A.
Viale Bologna, 298 - 47100 Forlì - Italy

Important Safety Information

You **MUST** read these warnings carefully before installing or using the hob. If you need assistance, contact our Customer Care Department on 08705 727 727.

Installation

- This appliance must be installed and serviced by a competent person as stated in the Gas Safety (Installation and Use) Regulations Current Editions and the IEE Wiring Regulations.
- For appliances installed in the Republic of Ireland please refer to NSAI-Domestic Gas Installations I.S.813 Current Editions and the ETCI Rules for Electrical Installations.
- Remove all packaging before using the hob.
- Ensure that the gas and electrical supply complies with the type stated on the rating plate, located near the gas supply pipe.
- Do not attempt to modify the hob in any way.

Child Safety

- This hob is designed to be operated by adults. Do not allow children to play near or with the hob.
- This appliance is not intended for use by children or other persons whose physical, sensory or mental capabilities or lack of experience and knowledge prevents them from using the appliance safely without supervision or instruction by a responsible person to ensure that they can use the appliance safely.
- The hob gets hot when it is in use. Children should be kept away until it has cooled.
- Children can also injure themselves by pulling pans or pots off the hob.

During Use

- This hob is intended for domestic cooking only. It is not designed for commercial or industrial purposes.
- This appliance is not connected to a combustion products evacuation device. It must be installed and connected in accordance with current installation regulations. Particular attention shall be given to the relevant requirements regarding ventilation.
- When in use a gas cooking hob will produce heat and moisture in the room in which it has been installed. Ensure there is a continuous air supply, keeping air vents in good condition or installing a cooker hood with a venting hose.
- Ensure a good ventilation around the appliance. A poor air supply could cause lack of oxygen.

- When using the hob for a long period time, the ventilation should be improved, by opening a window or increasing the extractor speed.
- Do not use this hob if it is in contact with water. Do not operate the hob with wet hands.
- Ensure the control knobs are in the 'OFF' position when not in use.
- When using other electrical appliances, ensure the cable does not come into contact with the hot surfaces of the cooking appliance.
- Unstable or misshapen pans should not be used on the hob as unstable pans can cause an accident by tipping or spillage.
- Never leave the hob unattended when cooking with oil and fats.
- Never use plastic or aluminium foil dishes on the hob.
- Perishable food, plastic items and aerosols may be affected by heat and should not be stored above or below the hob unit.
- This appliance cannot be cleaned with steam or with a steam cleaning machine.

Service

- This hob should only be repaired or serviced by an authorised Service Engineer and only genuine approved spare parts should be used.



Environmental Information

- After installation, please dispose of the packaging with due regard to safety and the environment.
- When disposing of an old appliance, make it unusable, by cutting off the cable.
- The symbol  on the product or on its packaging indicates that this product may not be treated as household waste. Instead it shall be handed over to the applicable collection point for the recycling of electrical and electronic equipment. By ensuring this product is disposed of correctly, you will help prevent potential negative consequences for the environment and human health, which could otherwise be caused by inappropriate waste handling of this product. For more detailed information about recycling of this product, please contact your local city office, your household waste disposal service or the shop where you purchased the product.

These instructions are only valid for countries whose identification symbols are shown on the cover of this instruction booklet and on the appliance itself.

Keep this instruction book for future reference and ensure it is passed on to any new owner.

Description of the Hobs

Model ZGF 642

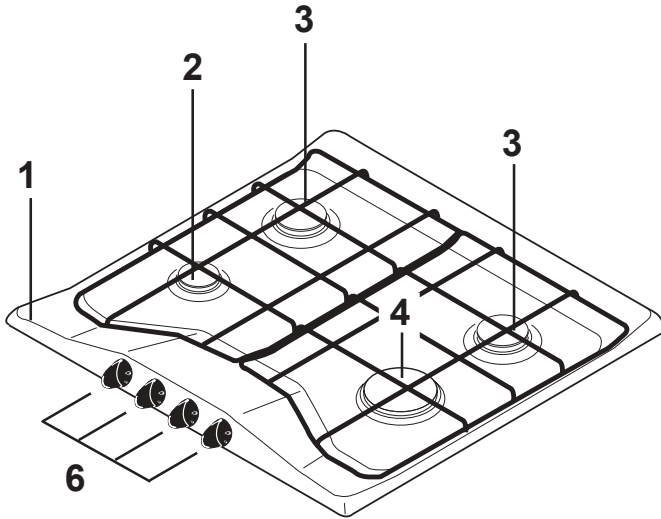

Model ZGF 692 C- ZGF 692 CT

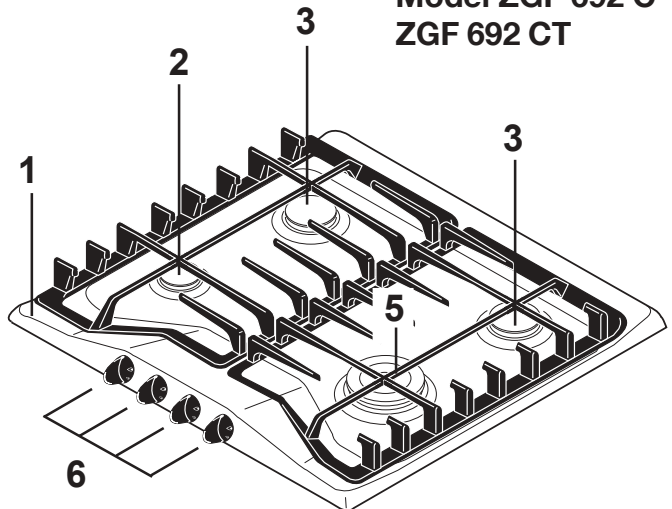

1. Hob Top
2. Auxiliary Burner
3. Semi-rapid Burner
4. Rapid Burner
5. Triple crown Burner
6. Control knobs

Instructions for the User



INSTALLATION

Any gas installation must be carried out by a registered competent person, and in accordance with existing rules and regulations.

The relevant instructions are to be found in the second section of this manual.

Please, ensure that, once the hob is installed, it is easily accessible for the engineer in the event of a breakdown.

WHEN THE HOB IS FIRST INSTALLED

Once the hob has been installed, it is important to remove any protective materials, which were put on in the factory.

The manufacturer will not accept liability, should the above instructions or any of the other safety instructions incorporated in this book be ignored.

Operation

Lighting the burners



For easier lighting, proceed before putting a pan on the pan support.



To light a burner:

- turn the relevant knob anti-clockwise to maximum position (★🔥), then push it down to ignite the burner.

Only for model ZGF 692 CT

- Upon ignition, keep the knob pushed down about **5 seconds**. This will allow the "thermocouple" (Fig. 1 - letter D) to be heated and the safety device to be switched off, otherwise the gas supply would be interrupted.
- Then adjust the flame as required.



If the burner does not ignite, turn the control knob to zero, and try again.



If you cannot light the flame even after several attempts, check the "cap" (Fig. - lett. A) and the "crown" (Fig. - lett. B) are in the correct position.

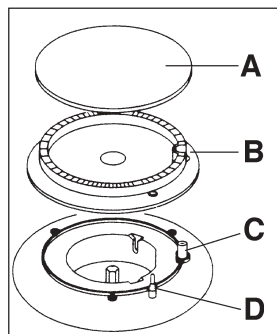

**Triple crown burner
(mod. ZGF 692 C/CT)**

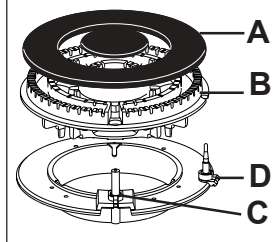

- A - Burner cap
- B - Burner crown
- C - Ignition electrode
- D - Thermocouple (only in model ZGF 692 CT)

- i** When switching on the mains, after installation or a power cut, it is quite normal for the spark generator to be activated automatically.
- i** **In the absence of electricity**, ignition can occur without the electrical device; in this case, approach the burner with a flame, push the relevant knob down and turn it anti-clockwise until it reaches the maximum position.
- i** If the control knobs become difficult to turn, please contact your local Service Force Centre.

Using the Wok Stand (only for model ZGF 692 C, ZGF 692 CT)

A wok stand is provided to enable you to use a round bottomed wok on the hob. The wok stand must only be used on the triple crown burner, and should not be used with any other type of wok or pan. When fitting the wok stand, ensure the recesses in the frame fit securely onto the bars of the pan supports, as shown in the picture.

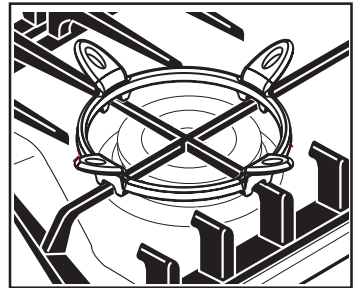

Using the hob correctly

To ensure maximum burner efficiency, it is strongly recommended that you use only pots and pans with a **flat** bottom fitting the size of the burner used, so that flame will not spread beyond the bottom of the vessel (see the table below).

Burner	minimum diameter	maximum diameter
Triple crown	180 mm	260 mm
Large (rapid)	180 mm	260 mm
Medium (semi-rapid)	120 mm	220 mm
Small (auxiliary)	80 mm	160 mm

i As soon as a liquid starts boiling, turn down the flame so that it will barely keep the liquid simmering.

! Use only pans or pots with flat bottom.

! If you use a saucepan which is smaller than the recommended size, the flame will spread beyond the bottom of the vessel, causing the handle to overheat.

i Carefully supervise cooking with **fat or oil**, since these types of foodstuff can result in a fire, if over-heated.

! The stainless steel can become tarnished if excessively heated. Therefore prolonged cooking with potstones, earthenware pans or cast-iron plates is inadvisable. Also, do not use aluminium foil to protect the top during use.



! Make sure pots do not protrude over the edges of the cooktop and that they are centrally positioned on the rings in order to obtain lower gas consumption.

! Do not place unstable or deformed pots on the rings: they could tip over or spill their contents, causing accidents.

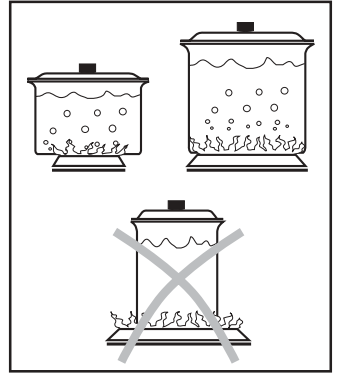
! Pots must not enter the control zone.



Maintenance and Cleaning

-  Before any maintenance or cleaning can be carried out, you must **DISCONNECT** the hob from the electricity supply.
-  The hob is best cleaned whilst it is still warm, as spillage can be removed more easily than if it is left to cool.
-  This appliance cannot be cleaned with steam or with a steam cleaning machine.

The Hob Top

Regularly wipe over the hob top using a soft cloth well wrung out in warm water to which a little washing up liquid has been added. Avoid the use of the following:

- household detergent and bleaches;
- impregnated pads unsuitable for non-stick saucepans;
- steel wool pads;
- bath/sink stain removers.

Should the hob top become heavily soiled, the following products are recommended:

- For stainless steel hobs use a proprietary stainless steel cleaner.
- For other hobs use Hob Brite or Bar Keepers Friend.

 **Do not leave acid or alkaline substances (e.g. vinegar, salt, lemon juice, etc.) on the cooktop.**

Pan Supports

To keep the pan supports in the correct position, they are hooked into hinges at the back of the hob.

Model ZGF 642: The pan supports can be lifted for easier cleaning, as shown in Fig. 1.

To remove the pan supports completely, proceed as shown in Fig. 2.

Model ZGF 692 C, ZGF 692 CT: The hob has two cast iron pan supports.

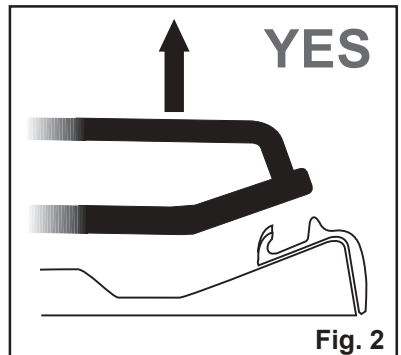
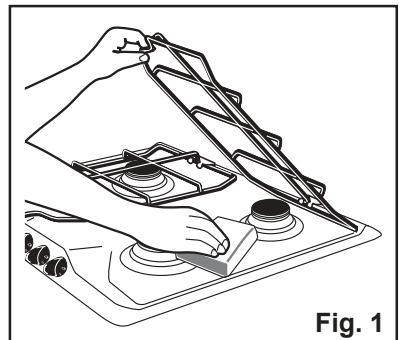



Take care when removing them. They are heavy and could damage the hob or your kitchen furniture if you let them fall.

Never turn the cast iron pan supports on the hinges, this could damage them.

To remove the cast iron pan supports completely, proceed as shown in Fig. 2.

Wash the pan supports using hot soapy water. If necessary, a paste cleaner or a soap impregnated steel wool pad can be used with caution.

After cleaning, be sure to wipe dry with a soft cloth and make sure that the pan supports are correctly positioned.

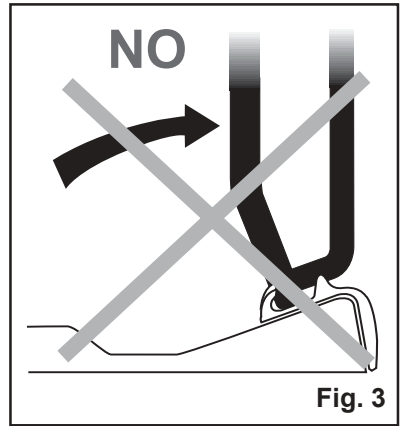

Fig. 3

The Burners

The burner caps and crowns can be removed for cleaning.

Wash the burners caps and crowns using hot soapy water, and remove marks with a mild paste cleaner. A well moistened soap impregnated steel wool pad can be used with caution, if the marks are particularly difficult to remove.

After cleaning, be sure to wipe dry with a soft cloth.

The Ignition electrode

The electric ignition is obtained through a ceramic electrode which contains a metal electrode. Keep these components very clean, to avoid difficult lighting, and check that the burner crown holes are not obstructed.

Something Not Working?

If the hob is not working correctly, please carry out the following checks before contacting your local Service Force Centre.

SYMPTOM	SOLUTION
<ul style="list-style-type: none">■ There is no spark when lighting the gas.	<ul style="list-style-type: none">◆ Check that the unit is plugged in and the electrical supply is switched on.◆ Check that the RCCB has not tripped (if fitted).◆ Check the mains fuse has not blown.◆ Check the burner cap and crown have been replaced correctly, e.g. after cleaning.
<ul style="list-style-type: none">■ The gas ring burns unevenly.	<ul style="list-style-type: none">◆ Check the main jet is not blocked and the burner crown is clear of food particles.◆ Check the burner cap and crown have been replaced correctly, e.g. after cleaning.

If after all these checks, your hob still does not operate correctly, contact your local Service Force Centre.

Please note that it will be necessary to provide proof of purchase for any in-guarantee service calls.

In-guarantee customers should ensure that the above checks have been made as the engineer will make a charge if the fault is not a mechanical or electrical breakdown.

TYPE OF GAS	BURNER POSITION	RAPID		SEMI-RAPID		AUXILIARY		TRIPLECROWN	
		MAX	MIN	MAX	MIN	MAX	MIN	MAX	MIN
NATURAL GAS 20 mbar VALUE = 37.78 MJ/m ³ Ws - 50.7 MJ/ m ³	NOMINAL THERMAL POWER kW	3.0	0.65	2.0	0.45	1.0	0.33	4.0	1.2
	NOMINAL FLOW RATE m ³ /h	0.286	0.057	0.190	0.038	0.095	0.028	0.381	0.114
	NOZZLE REFERENCE 1/100mm	119	Adjust.	96	Adjust.	70	Adjust.	146	Adjust.
LPG GAS 28-30/37 mbar VALUE = 49.92 MJ/Kg	NOMINAL THERMAL POWER kW	2.8	0.65	2.0	0.45	1.0	0.33	4.0	1.2
	NOMINAL FLOW RATE g/h	202	43.5	144	29	72	21,5	291	87
	NOZZLE REFERENCE 1/100mm	86	40	71	32	50	28	98	56

Important safety requirements

This hob must be installed in accordance with the Gas Safety (Installation and Use) Regulations (Current Edition) and the IEE Wiring Regulations (Current Edition).

For appliances installed in the Republic of Ireland please refer to NSAI- Domestic Gas Installation I.S. 813 Current Editions and the ETCI Rules for Electrical Installations.

Provision for Ventilation

Detailed recommendations are contained in the following British Standards Codes Of Practice: B.S. 6172/ B.S. 5440, Par. 2 and B.S. 6891 Current Editions.

The hob should not be installed in a bed sitting room with a volume of less than 20 m³. If it is installed in a room of volume less than 5 m³ an air vent of effective area of 100 cm² is required. If it is installed in a room of volume between 5 m³ and 10 m³ an air vent of effective area of 50 cm² is required, while if the volume exceeds 11 m³ no air vent is required.



However, if the room has a door which opens directly to the outside no air vent is required even if the volume is between 5 m³ and 11 m³.

If there are other fuel burning appliances in the same room, B.S. 5440 Part 2 Current Edition, should be consulted to determine the requisite air vent requirements.

For appliances installed in the Republic of Ireland please refer to the NSAI- Domestic Gas Installation I.S. 813 Current Editions Table Four.

Installation

IMPORTANT

-  This hob must be installed by a competent person to the relevant Gas Standards.
-  Any gas installation must be carried out by a registered competent person.

Please, ensure that, once the hob is installed, it is easily accessible for the engineer in the event of a breakdown.

The manufacturer will not accept liability, should the above instructions or any of the other safety instructions incorporated in this instruction booklet be ignored.

On the end of the shaft, which includes the G 1/2" threaded elbow, adjustment is fixed so that the washer is fitted between the components as shown in the diagram. Screw the parts together without using excessive force.

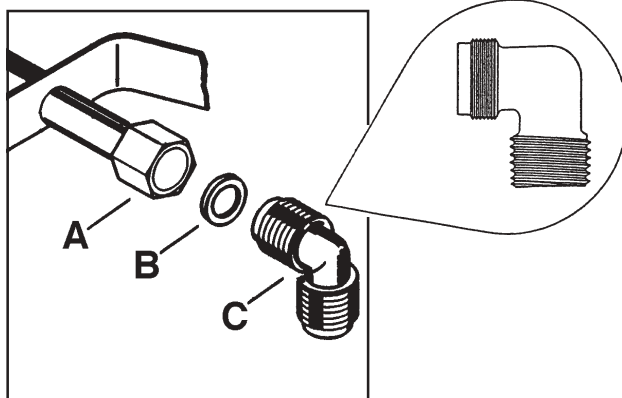

- A) End of shaft with nut
- B) Washer
- C) Elbow

Gas Connection

Connection to the gas supply should be with either rigid or semi-rigid pipe, i.e. steel or copper.

The connection should be suitable for connecting to R 1/2 (1/2 BSP male thread).

When the final connection has been made, it is essential that a thorough leak test is carried out on the hob and installation.

Ensure that the main connection pipe does not exert any strain on the hob.

 **It is important to install the elbow correctly, with the shoulder on the end of the thread, fitted to the hob connecting pipe.**

Failure to ensure the correct assembly will cause leakage of gas.

Location

The hob may be located in a kitchen, a kitchen/diner or bed sitting room, but not in a bathroom, shower room or garage.

Ensure that there is a minimum distance of 55 mm between the rear cut out edge and the wall.

A minimum distance of 100 mm must be left between the side edges of the cut out and any adjacent cabinets or walls.

The minimum distance combustible material can be fitted above the hob in line with the edges of the hob is 400 mm. If it is fitted below 400 mm a space of 50 mm must be allowed from the edges of the hob.

The minimum distance combustible material or a cooker hood can be fitted above the hob is 650 mm.

For appliances installed in the Republic of Ireland please refer to NSAI- Domestic Gas Installation I.S 813 Current Edition Section 7- Permitted Locations of Appliance.

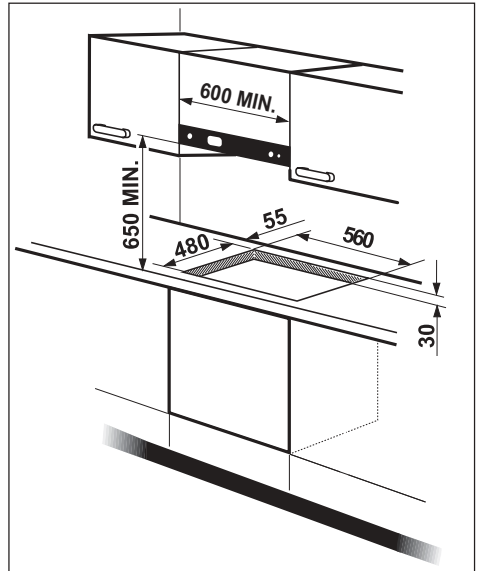

Fitting the Hob into the Worktop

Carry out the building in of the hob as follows:

1. place the seals supplied with the hob on the side edges of the cut out and at 8 mm. from the front and rear edges, as shown in the diagram, taking care that the seals meet without overlapping;
2. place the hob in the cut out, taking care that it is centred;
3. fix the hob with the relevant fixing clamps and screws, as shown in the diagram. When the screws have been tightened, the excess seal can be removed.

The edge of the hob forms a double seal which prevents the ingress of liquids.

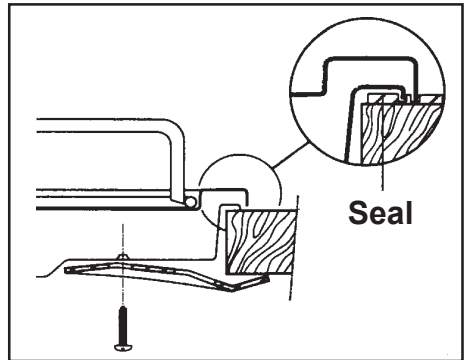
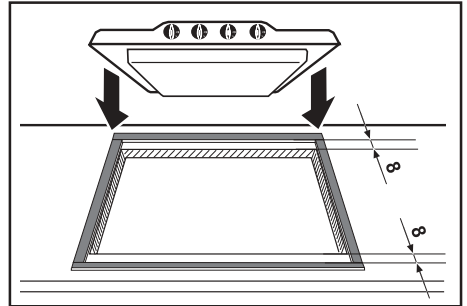

Building In

Building over a cupboard or drawer

If the hob is to be installed above a cupboard or drawer it will be necessary to fit a heat resistant board below the base of the hob on the underside of the work surface.

It is also recommended to carry out the electrical connection to the hob as shown in diagrams 1 and 2.

Building over a kitchen unit with door

Proper arrangements must be taken in designing the furniture unit, in order to avoid any contact with the bottom of the hob which can be heated when it is operated. The recommended solution is shown in diagram 3.

The panel fitted under the hob ("a") should be easily removable to allow easy access if technical assistance is needed. The space behind the kitchen unit ("b") can be used for connections.

Dimensions are given in mm.

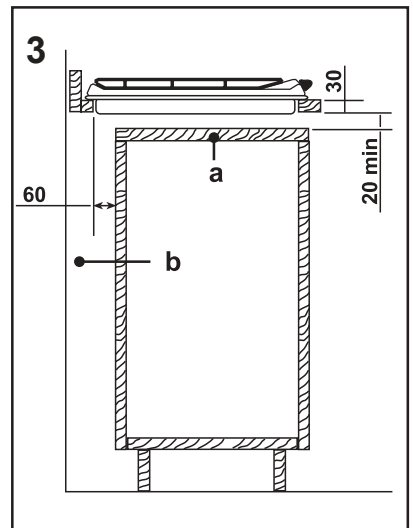
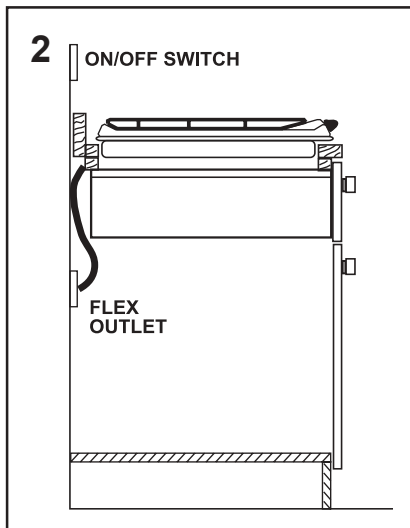
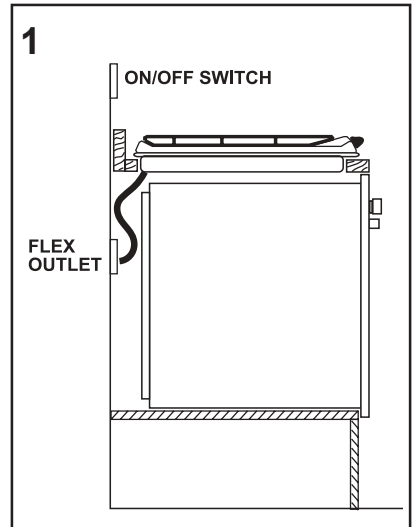

Electrical Connections

⚠ Any electrical work required to install this hob should be carried out by a qualified electrician or competent person, in accordance with the current regulations.

THIS HOB MUST BE EARTHED.

Electrical Requirements

Any permanent electrical installation must comply with the latest I.E.E. Regulations and local Electricity Board regulations. For your own safety this should be undertaken by a qualified electrician, e.g. your local Electricity Board, or a contractor who is on the roll of the National Inspection Council for Electrical Installation Contracting (NICEIC).

The manufacturer declines any liability should these safety measures not be observed.

This hob is designed to be connected to a 230 V 50 Hz AC electrical supply.

Before switching on, make sure the electricity supply voltage is the same as that indicated on the hob rating plate. The rating plate is located on the bottom of the hob. A copy is attached on the back cover of this book.

The hob is supplied with a 3 core flexible supply cord incorporating a 3 amp plug fitted. In the event of having to change the fuse, a 3 amp ASTA approved (BS 1362) fuse must be used.

Should the plug need to be replaced for any reason, the wires in the mains lead are coloured in accordance with the following code:

Green and Yellow	- Earth
Blue	- Neutral
Brown	- Live



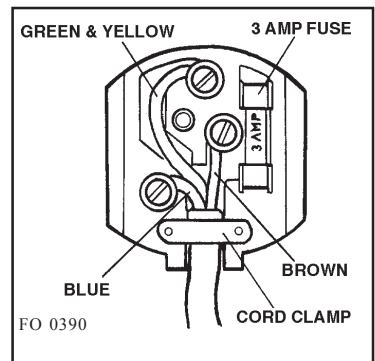

- 1) Connect the green and yellow (earth) wire to the terminal in the plug which is marked with the letter 'E' or the earth symbol \perp or coloured green and yellow.
- 2) Connect the blue (neutral) wire to the terminal in the plug which is marked with the letter 'N' or coloured black.



- 3) Connect the brown (live) wire to the terminal in the plug which is marked with the letter 'L' or coloured red.

Upon completion there must be no cut, or stray strands of wire present and the cord clamp must be secure over the outer sheath.

 **A cut off plug inserted into a 13 amp socket is a serious safety (shock) hazard. Ensure that the cut off plug is disposed of safely.**

 **The replacement of electric cable must be carried out exclusively by the service force centre or by personnel with similar competencies, in accordance with the current regulations.**

Permanent Connection

In the case of a permanent connection, it is necessary that you install a double pole switch between the hob and the electricity supply (mains), with a minimum gap of 3 mm between the switch contacts and of a type suitable for the required load in compliance with the current electric regulations.

The switch must not break the yellow and green earth cable at any point.

 **Ensure that the hob supply cord does not come into contact with surfaces with temperatures higher than 50 deg. C.**

Wiring diagram

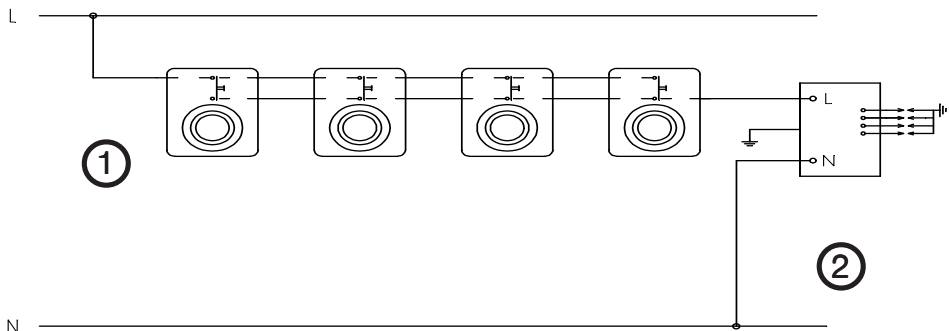

1. TAPS IGNITOR SWITCHES

2. IGNITOR UNIT

Fault Finding

Preliminary Electrical Systems Check

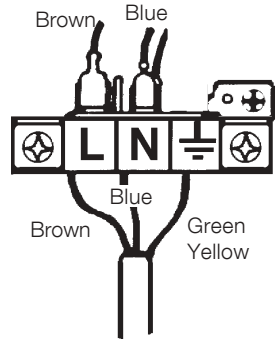
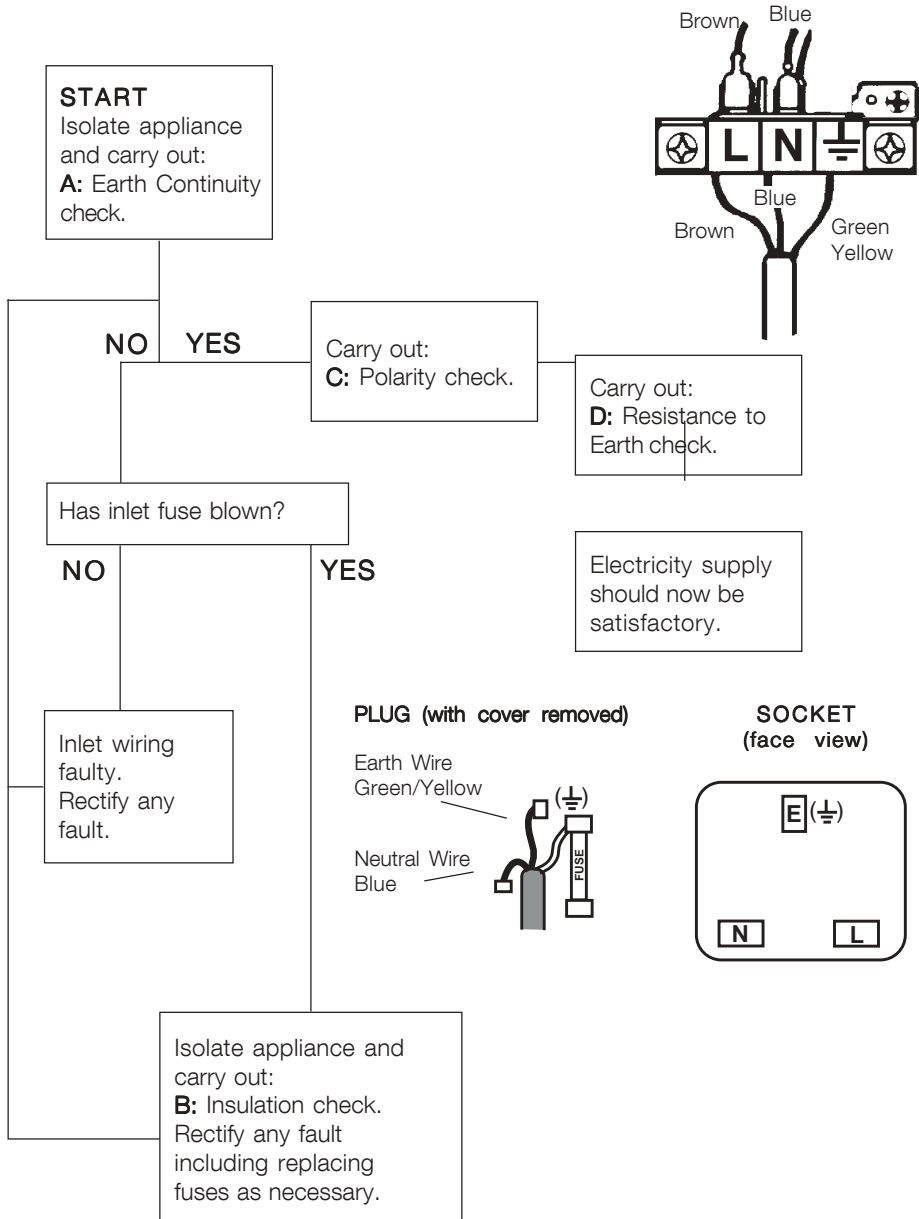

PLUG (with cover removed)

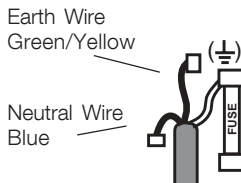

SOCKET (face view)

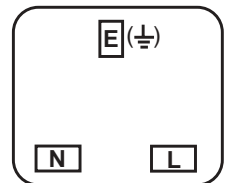

A. EARTH CONTINUITY CHECK

Appliance must be electrically disconnected - meter set on W (Ohms) x 1 scale and adjust zero if necessary.

- Test leads from any appliance earth point to earth pin on plug. Resistance should be less than 0.1 W (Ohm), check all earth wires for continuity and all contacts clean and tight.

B. INSULATION CHECK

Appliance electrically disconnected, all switches ON.

- a) meter set on W (Ohms) x 1 scale.

Test leads from L to N in appliance terminal block. If meter reads «0» then there is a short circuit.

- b) meter set on W (Ohm) x 100 scale.

Repeat test with leads from L to E. If meter reads less than ∞ (infinity) there is a fault.

NOTE - Should it be found that the fuse has failed but no fault is indicated - a detailed continuity check (i.e. by disconnecting and checking each component) is required to trace the faulty component.

It is possible that a fault could occur as a result of local burning/arcing but no fault could be found under test. However a detailed visual inspection should reveal evidence of burning around the fault.

Ignition System / Gas Ignition

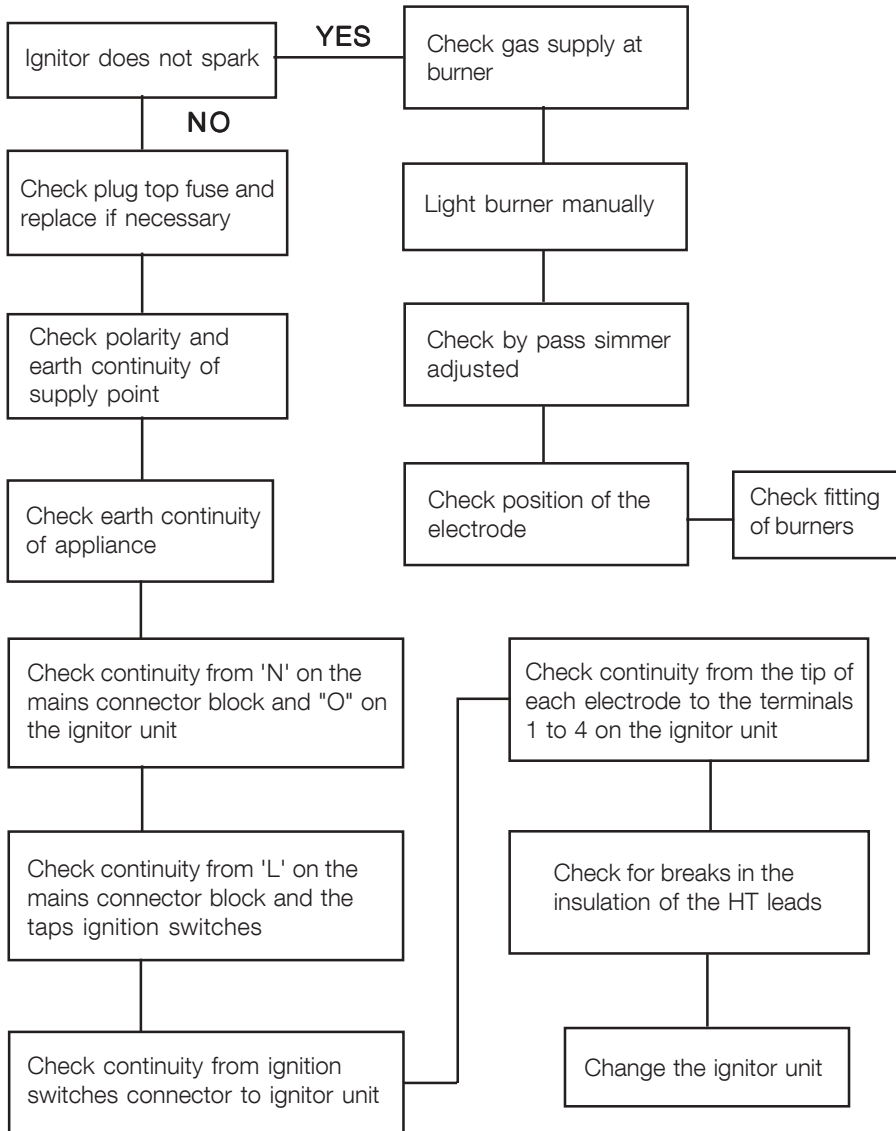

Commissioning

When the hob has been fully installed it will be necessary to check the minimum flame setting. To do this, follow the procedure below.

- ☞ 1) Turn the gas tap to the MAX position and ignite.
- 2) Set the gas tap to the MIN flame position then turn the control knob from MIN to MAX several times. If the flame is unstable or is extinguished follow the procedure below.

Procedure:

- ☞ 1) Re-ignite the burner and set to MIN.
- 2) Remove the control knob.
- 3) To adjust, use a thin bladed screwdriver and turn the adjustment screw (see diagram) until the flame is steady and does not extinguish, when the knob is turned from MIN to MAX. Repeat this procedure for all burners.

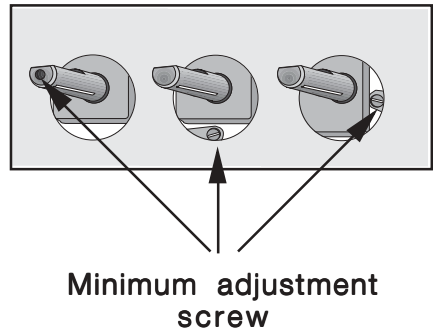

Pressure Testing

The pressure testing must be carried out on the burners.

- ☞ Proceed as follows:
 - 1) Remove the pan supports and the burner caps and crowns.
 - 2) Fit manometer tube over the injector.
 - 3) Turn on the burner gas supply and ignite another burner supply.
The pressure reading should be nominally 20 mbar and must be between 17 mbar and 25 mbar.
 - 4) Turn off the burner supplies.

Conversion from Natural Gas to LPG



IMPORTANT

The replacement/conversion from natural gas to LPG should only be undertaken by a competent person.

It is important to note that this model is designed for use with natural gas but can be converted for use with butane or propane gas providing the correct injectors are fitted. The gas rate is adjusted to suit.

Method



- 1) Ensure that the gas taps are in the 'OFF' position
- 2) Isolate the hob from the electricity supply
- 3) Remove all pan supports, burner caps, rings, crowns and control knobs.
- 4) With the aid of a 7mm box spanner the burner injectors can then be unscrewed and replaced by the appropriate LPG injectors.

TO ADJUST THE GAS RATE

With the aid of a thin bladed screwdriver completely tighten down the bypass adjustment screw. Upon completion stick the replacement rating plate on the under side of the hob.

Guarantee/Customer Service

Standard guarantee conditions

We, Zanussi-Electrolux, undertake that if within 12 months of the date of the purchase this Zanussi-Electrolux appliance or any part thereof is proved to be defective by reason only of faulty workmanship or materials, we will, at our option repair or replace the same FREE OF CHARGE for labour, materials or carriage on condition that:

- The appliance has been correctly installed and used only on the electricity supply stated on the rating plate.
- The appliance has been used for normal domestic purposes only, and in accordance with the manufacturer's instructions.
- The appliance has not been serviced, maintained, repaired, taken apart or tampered with by any person not authorised by us.
- Electrolux Service Force Centre must undertake all service work under this guarantee.
- Any appliance or defective part replaced shall become the Company's property.
- This guarantee is in addition to your statutory and other legal rights.

Exclusions

- Damage or calls resulting from transportation, improper use or neglect, the replacement of any light bulbs or removable parts of glass or plastic.
- Costs incurred for calls to put right an appliance which is improperly installed or calls to appliances outside the United Kingdom.
- Appliances found to be in use within a commercial environment, plus those which are subject to rental agreements.
- Products of Electrolux manufacturer that are not marketed by Electrolux.

Service and Spare Parts

In the event of your appliance requiring service, or if you wish to purchase spare parts, please contact your local Service Force Centre by telephoning

0870 5 929 929

Your telephone call will be automatically routed to the Service Force Centre covering your postcode area.

For the address of your local Service Force Centre and further information about Service Force, please visit the website at

www.serviceforce.co.uk

Before calling out an engineer, please ensure you have read the details under the heading "Something not working"

When you contact the Service Force Centre you will need to give the following details:

1. Your name, address and postcode.
2. Your telephone number.
3. Clear concise details of the fault.
4. The model and Serial number of the appliance (found on the rating plate).
5. The purchase date.

Please note a valid purchase receipt or guarantee documentation is required for in guarantee service calls.

Customer Care

For general enquiries concerning your Electrolux appliance, or for further information on Electrolux products please contact our Customer Care Department by letter or telephone at the address below or visit our website at www.electrolux.co.uk

Customer Care Department
Electrolux Major Appliances
Addington Way
Luton
Bedfordshire, LU4 9QQ
Tel: 08705 727 727 (*)

(*) Calls may be recorded for training purposes

European Guarantee

This appliance is guaranteed by Electrolux in each of the countries listed at the back of this user manual, for the period specified in the appliance guarantee or otherwise by law. If you move from one of these countries to another of the countries listed below the appliance guarantee will move with you subject to the following qualifications:

- The appliance guarantee starts from the date you first purchased the appliance which will be evidenced by production of a valid purchase document issued by the seller of the appliance.
- The appliance guarantee is for the same period and to the same extent for labour and parts as exists in your new country of residence for this particular model or range of appliances.
- The appliance guarantee is personal to the original purchaser of the appliance and cannot be transferred to another user.
- The appliance is installed and used in accordance with instructions issued by Electrolux and is only used within the home, i.e. is not used for commercial purposes.
- The appliance is installed in accordance with all relevant regulations in force within your new country of residence.

The provisions of this European Guarantee do not affect any of the rights granted to you by law.



Albania	+35 5 4 261 450	Rr. Pjeter Bogdani Nr. 7 Tiranë
Belgique/België/Belgien	+32 2 363 04 44	Bergensesteenweg 719, 1502 Lembeek
Česká republika	+420 2 61 12 61 12	Budějovická 3, Praha 4, 140 21
Danmark	+45 70 11 74 00	Sjællandsgade 2, 7000 Fredericia
Deutschland	+49 180 32 26 622	Muggenhofer Str, 135, 90429 Nürnberg
Eesti	+37 2 66 50 030	Pämu mnt, 153, 11624 Tallinn
España	+34 902 11 63 88	Carretera M-300, Km. 29,900 Alcalá de Henares Madrid
France	www.electrolux.fr	
Great Britain	+44 8705 929 929	Addington Way, Luton, Bedfordshire LU4 9QQ
Hellas	+30 23 10 56 19 70	4, Limnou Str., 54627 Thessaloniki
Hrvatska	+385 1 63 23 338	Slavonska avenija 3, 10000 Zagreb
Ireland	+353 1 40 90 753	Long Mile Road Dublin 12
Italia	+39 (0) 434 558500	C.so Lino Zanussi, 26 - 33080 Porcia (PN)
Latvija	+37 17 84 59 34	Kr. Barona iela 130/2, LV-1012, Riga
Lituania	+370 5 27 80 609	Ozo 10A, LT 08200 Vilnius
Luxembourg	+35 2 42 43 13 01	Rue de Bitbourg, 7, L-1273 Hamm
Magyarország	+36 1 252 1773	H-1142 Budapest XIV, Erzsébet királyné útja 87
Nederland	+31 17 24 68 300	Vennootsweg 1, 2404 CG - Alphen aan den Rijn
Norge	+47 81 5 30 222	Risløkkvn. 2 , 0508 Oslo
Österreich	+43 18 66 400	Herziggasse 9, 1230 Wien
Polska	+48 22 43 47 300	Electrolux Poland sp. z o.o., ul. Kolejowa 5/7, 01-217 Warszawa
Portugal	+35 12 14 40 39 39	Quinta da Fonte - Edificio Gonçalves Zarco - Q 35 -2774-518 Paço de Arcos
Romania	+40 21 451 20 30	Str. Garii Progresului 2, S4, 040671 RO
Schweiz - Suisse - Svizzera	+41 62 88 99 111	Industriestrasse 10, CH-5506 Mägenwil
Slovenija	+38 61 24 25 731	Gerbičeva ulica 98, 1000 Ljubljana
Slovensko	+421 2 43 33 43 22	Electrolux Slovakia s.r.o., Electrolux Domáce spotrebiče SK, Seberínho 1, 821 03 Bratislava
Suomi	www.electrolux.fi	
Sverige	+46 (0)771 76 76 76	Electrolux Service, S:t Göransgatan 143, S-105 45 Stockholm
Türkiye	+90 21 22 93 10 25	Tarlabası caddesi no : 35 Taksim İstanbul
Россия	+7 095 937 7837	129090 Москва, Олимпийский проспект, 16, БЦ "Олимпик"

www.electrolux.com

www.zanussi-electrolux.co.uk

Free Manuals Download Website

<http://myh66.com>

<http://usermanuals.us>

<http://www.somanuals.com>

<http://www.4manuals.cc>

<http://www.manual-lib.com>

<http://www.404manual.com>

<http://www.luxmanual.com>

<http://aubethermostatmanual.com>

Golf course search by state

<http://golfingnear.com>

Email search by domain

<http://emailbydomain.com>

Auto manuals search

<http://auto.somanuals.com>

TV manuals search

<http://tv.somanuals.com>