

ZANUSSI

**Instructions
for the use and care
of Z 22/16 PR
fridge/freezer**

It is most important that this instruction book should be retained with the appliance for future reference. Should the appliance be sold or transferred to another owner, or should you move house and leave the appliance, always ensure that the book is supplied with the appliance in order that the new owner can be acquainted with the functioning of the appliance and the relevant warnings.

Refrigeration Warnings

THESE WARNINGS ARE PROVIDED IN THE INTEREST OF SAFETY. YOU MUST READ THEM CAREFULLY BEFORE INSTALLING OR USING THE APPLIANCE.

- This appliance is designed to be operated by adults. Children should not be allowed to tamper with the controls or play with the product.
- Any electrical work required to install this appliance should be carried out by a qualified electrician.
- This product should be serviced by an authorised Zanussi Network Service Centre, and only genuine Zanussi spare parts should be used.
- It is dangerous to alter the specifications or modify the product in any way.
- Care must be taken to ensure that the appliance does not stand on the electrical supply cable.
- Zanussi domestic refrigerators and fridge/freezers are designed to be used specifically for the storage of edible foodstuffs only.
Frozen food must not be re-frozen once it has been thawed out.
- Manufacturers' storage recommendations should be strictly adhered to. Refer to relevant instructions.
- There are working parts in this product which heat up. Always ensure that there is adequate ventilation as a failure to do this will result in component failure and possible food loss. See installation instructions.
- Parts which heat up should not be exposed. Wherever possible the back of the product should be against a wall.
- Before any cleaning or maintenance work is carried out, be sure to switch off the appliance and unplug.
- The inner lining of the appliance consists of channels through which the refrigerant passes. If this should be punctured this would damage the appliance beyond repair and cause food loss. **DO NOT USE SHARP INSTRUMENTS** to scrape off frost or ice. Frost may be removed by using the scraper provided. Under no circumstances should solid ice be forced off the liner. Solid ice should be allowed to thaw when defrosting the appliance. See defrost instructions.
- The appliance should be left for 2 hours after installation before it is turned on in order to allow the refrigerant to settle.
- Do not place carbonated or fizzy drinks in the freezer as it creates pressure on the container, which may cause it to explode, resulting in damage to the appliance.
- This appliance is heavy. Care should be taken when moving it.
- Ice lollies can cause frost burns if consumed straight from the freezer.
- Under no circumstances should you attempt to repair the appliance yourself. Repairs carried out by inexperienced persons may cause injury or more serious malfunctioning. Refer to your local Zanussi Network Centre, and always insist on genuine **Zanussi spare parts.**

Control panel

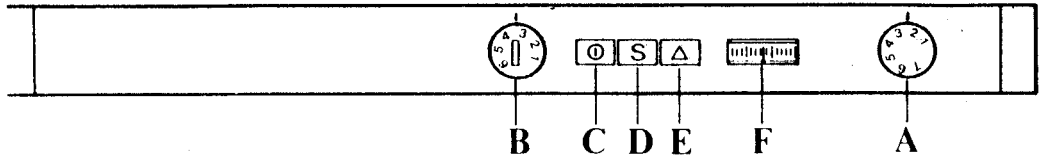

ig. 1

- 1. Refrigerator temperature control knob
- 2. Freezer temperature control knob
- 3. Green pilot light switch for normal freezer operation
- 4. Yellow pilot light switch for quick-freeze operation
- 5. Red warning light
- 6. Thermometer

Installation

Please note

If you are discarding an old refrigerator that has a lock on the door, please ensure that the lock is made unusable to avoid accidents to young children.

Electricity Supply

The appliance is for operation on a 220/240 v. 50 c/s supply, so be sure that your electricity supply voltage is within the range marked on the nameplate inside the cabinet.

Earthing

Warning: THIS APPLIANCE MUST BE EARTHED. The manufacturer declines any liability should this safety measure not be observed.

Electrical connection

Important

The wires in this mains lead are coloured in accordance with the following code:

GREEN AND YELLOW - EARTH
BLUE - NEUTRAL
BROWN - LIVE

If you fit your own plug, the colours of the wires in the mains lead of your appliance may not correspond with the markings identifying the terminals in your plug, this is what you have to do: Connect the green and yellow (earth) wire to the terminal in the plug which is marked with the letter «E» or the earth \perp symbol or coloured green, or green and yellow.

Connect the blue (neutral) wire to the terminal in the plug which is marked with the letter «N» or coloured black.

Connect the brown (live) wire to the terminal which is marked with the letter «L» or coloured red.

If the plug is not suitable it must be cut off and the appropriate plug fitted. The cut off plug should be disposed of to prevent the hazard of electric shocks in case it should be plugged into a 13 Amp socket in another part of your home.

The plug moulded on to the cord incorporates a fuse. For replacement, use a 13 Amp BS 1362 fuse. Only ASTA approved fuses should be used.

The fuse cover/carrier must be replaced in the event of changing fuse.

The right fuse cover/carrier colour is the one shown by the coloured insert at the base of the plug.

The plug must not be used if the fuse cover/carrier is lost.

A replacement cover/carrier must be obtained from Zanussi Service Agents whose addresses are listed on the attached «Zanussi Service Agents Nationwide».

THIS APPLIANCE COMPLIES WITH E.E.C. DIRECTIVE NO. 76/889 OF 4.11.76 RELATIVE TO RADIO INTERFERENCE SUPPRESSION.

Location and Levelling

Place the appliance away from heat sources and in such a way that air can circulate freely to the back of the cabinet. Level by adjusting the special levelling feet on the bottom of the cabinet.

Before using

Remove all securing tapes. Wash inside the appliance with lukewarm water and a little bicarbonate of soda (one teaspoonful to one quart of water). Do not use soap or detergent as the smell might linger. Dry thoroughly. Repeat the above for regular cleaning of your appliance.

Operation

The appliance has two completely independent compartments — one for refrigeration and the other for deep-freezing. The upper compartment is a normal refrigerator suitable for storing food and drinks. The lower compartment is a four-star (****) freezer suitable for long term storage of commercially frozen food marked by the three-star symbol (***), (i.e. for 3 months, unless otherwise stated by the manufacturer), for freezing fresh food and also for making ice cubes. Do not exceed the storage times shown by the manufacturers on the commercially frozen food packets (i.e.: the storage limits indicated by the number of «stars»).

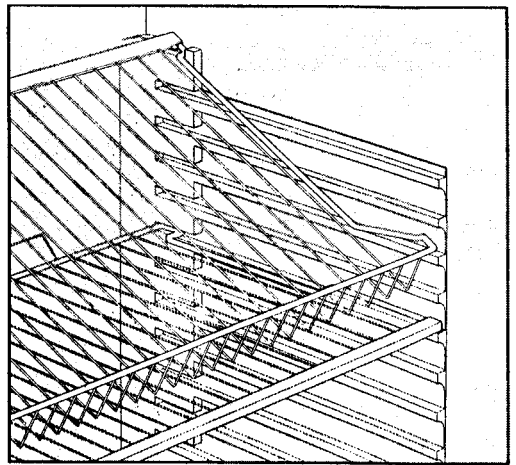

fig. 2

Refrigerator-Starting-Up, Temperature, Regulation and Storage

To start the refrigerator turn the knob of the thermostat A - Fig. 1 clockwise beyond «●» position. The temperature increases (less cold) by turning the thermostat knob anti-clockwise; it decreases (more cold) turning it clockwise. A medium setting is generally the most suitable. However, a higher setting (more cold) may be required if the refrigerator is affected by abnormal operating conditions such as poor ventilation, high ambient temperature and frequent door openings.

To obtain the best results from the refrigerator neither hot food nor liquids, which may evaporate, should be placed inside the refrigerator compartment; cover all food, particularly food with a strong aroma; place meat to be stored in a special

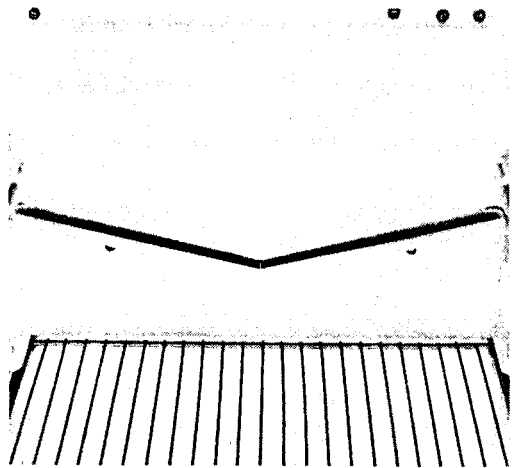

fig. 3

hermetically-sealed box, which should be placed on the glass shelf above the vegetable crispers, do not pack shelves too tightly or cover shelves with paper, so as not to obstruct the free circulation of air.

The inner walls of the refrigerator compartment incorporate a number of shelf-carrying runners which allow the shelves to be placed at the various levels. Furthermore, the upper shelf can be tilted as in Fig. 2. This will make a handy bottle rack for wines and beverages.

Drink-chiller

The drink-chiller, which — depending on the type of appliance — is located either on the inner door or on the inner liner ceiling of the refrigerator compartment, can easily be removed from its runners for filling up.

To draw out the drink, push the glass against the arms of the special dispenser tap. When the glass is removed, the tap closes automatically. To clean the drink chiller, fill with hot water adding a tablespoonful of baking soda, then wash taking care to turn the tap on and off several times so as to clear it of any sugar deposits that may have formed.

Empty the container and rinse with clean water.

Defrosting the refrigerator

Frost is automatically eliminated from the evaporator of the refrigerator compartment every time the compressor stops.

Defrost water drains out through a trough into a special container on the back of the appliance where it evaporates.

Important

The defrost water drain opening (Fig. 3), located at the center of the special conveyor of the refrigerator

compartment, should be cleaned at regular intervals in order to prevent the defrost water from overflowing and dripping onto the food stored in this compartment.

Deep-freezer - Starting-Up - Temperature Adjustment

To start the freezer, set thermostat knob «B» Fig. 1 on number 4 and then depress controls «C» and «D» Fig. 1: «NORMAL» (storage) operation is obtained by depressing switch «C» so that its green light turns on, whereas «SUPER» (quick-freeze) operation is obtained by depressing switch «D» so that its yellow light comes on. On the «NORMAL» setting (green light ON), the temperature in the freezer is automatically adjusted by a thermostat in order to obtain a suitable temperature for the storage of the frozen and deep-frozen food. However, if the appliance works in unfavourable room conditions such as poor ventilation, high ambient temperature and frequent door openings, it might be necessary to select a higher setting (to obtain a colder temperature) by turning the thermostat knob (B - Fig. 1) clockwise to the higher numbers. Conversely, if you require less cold, turn the knob in the opposite direction towards the lower numbers.

Caution

The red warning light (E - Fig. 1), which is to be found next to the controls, indicates, when it lights up, that the temperature in the freezer has climbed to a level where the safe storage of frozen food is no longer ensured. Needless to say, when the appliance is first started or when fresh food to be frozen is first placed in the freezer, this warning light will stay on until the temperature has dropped to a safe level for the storage of the foodstuffs.

Deep-freezer - Freezing of Foods

Any fresh food to be frozen should be stored in the upper and lower compartments which are designed for this purpose. If the appliance has not worked previously, it must be left to run for at least three hours with the fast-freeze switch on the «ON» position (yellow light «on») before loading with food to be frozen.

However, if the appliance is already running, switch to quick-freeze operation (SUPER» - yellow pilot light on) at least 4 hours before introducing the fresh food to be frozen.

Once the fresh food is placed in the freezer, let it run on quick-freeze for another 24 hours, after which the freezing process may be regarded as completed.

Then, switch back to normal operation (NORMAL» yellow pilot light off). In order to freeze food properly, proceed as follows:

Only use top quality foodstuffs which are fresh and properly cleaned, since freezing preserves quality but cannot improve it. Prepare foodstuffs for deep-freezing in small portions so that each piece can be frozen rapidly right the way through. This procedure allows you to use, as required, complete portions rather than thawing out a large piece when only a small amount is needed. Remember that frozen food once thawed, deteriorates rapidly if frozen again.

Always remember that lean foodstuffs store better and longer than fat foodstuffs and that salt reduces the freezing time. Wrap the food up in aluminium foil or polythene and make sure that the packages are hermetically sealed.

Do not place fresh food to be frozen close to frozen food already stored in the freezer.

Always leave the door closed when freezing.

Do not, at any one time, freeze fresh foods in a quantity greater than 28,65 lbs.

Warning

Water ices, if consumed immediately after removal from the freezer, can possibly result in a low-temperature skin burn condition. It can be dangerous to place in the freezer sealed vessels that contain carbonated liquids (fizzy drinks, etc.).

Deep-freeze - Storage of foods

Net storage volume of the freezer:
cu. ft. 4.59.

Gross storage volume of the freezer:
cu. ft. 5.47.

If the appliance has not worked previously or after a period of inaction, it must be left to run for at least three hours with the fast-freeze switch on the «on» position (yellow light «on») before storing frozen food inside; then switch it off (yellow light «off»). When the appliance is on normal operation (storage), the temperature in the freezer is kept steady by the thermostat which can be adjusted by turning knob B - Fig. 1. The best temperature for safe storage of frozen food should be a little colder or at least equal to -18°C .

To correctly adjust the temperature, follow the directions under paragraph: «Freezer - starting-up and temperature adjustment». To obtain the best service from the appliance it is advisable to make sure that the frozen foods have been properly stored by the retailer and that their transfer from retailer to consumer is effected in the shortest time possible. Moreover it is important not to exceed the storage period indicated by the producer of the frozen food. Also, do not open the door often or leave it open longer than absolutely necessary.

Important

If the power fails when storing frozen food, do not open the door at all while the power is off. The frozen food will not deteriorate in any way if the power failure is of short duration and the freezer is full.

The thermometer «F» - Fig. 1 incorporated in this model, has a double temperature scale extending from negative to positive degrees Centigrade and the readings given by the same are to be regarded as a mere indication.

To correctly freeze and store the food, follow the directions given in the preceding paragraphs.

Useful hints

On the door liner you will find a pictorial guide with numbers shown next to each type of meat or food and these numbers indicate the approximate storage time in months from the freeze-in date.

On the front part of the sliding drawers or freezer compartments are fitted special contents cards which can be out and on which you may enter by pencil a description of the contents.

Warning

In the upper part of the freezer compartment is located the inner light. If the door is kept open for an extended period of time, the inner light will turn off automatically. This light will then go on and off to avoid building up too much heat.

Defrosting the freezer

Whilst in operation the inner liner becomes progressively covered with frost. This should be removed with the special plastic scraper provided whenever the thickness of frost exceeds 1/4. During this operation it is not necessary to switch off the power supply or remove the foodstuffs.

However, when the ice becomes very thick on the inner liner, complete defrosting should be carried out as ice acts as an insulator and prevents the cold from reaching the food.

It is advisable to carry out this operation when the appliance is empty. If frozen foods are removed to defrost the deep freezer, wrap them in several newspaper sheets and place in a cold spot. A temperature rise of the frozen food packs during defrosting may shorten the storage life thus the period of up to 3 months quoted may not apply.

To carry out complete defrosting proceed as follows:

- Turn off the normal operation switch (C - Fig. 1), the green light will go out;
- Leave the door open and place a bowl of hot water inside the freezer compartment (with a piece of cardboard underneath as a protection); the hot water will accelerate the defrosting process.

Defrost water will drain through the trough placed at the center front side of the appliance, between the base and the door, and it should be collected by placing a basin (container) underneath.

When defrosting is completed, dry the freezer thoroughly, close the door and start the appliance by depressing switches «C» and «D» (green and yellow lights will come on) and let it run for at least three hours, then replace the food in the freezer and disconnect the quick-freeze switch (the yellow light will go out).

Door reversal directions

Attention

Unplug the appliance from the power supply before carrying out the below-mentioned operations.

To carry out this reversal, rest the appliance on the back and go through the following steps:

a. Top, middle and bottom hinge

Using a blade screwdriver or a spanner, remove that door rotating pivot (A - Fig. 4) from the bottom hinge; slide out the lower door from the middle hinge; remove the middle hinge; slide out the door from the top hinge. Remove the door rotating pivot (A - Fig. 5) from the top hinge (B - Fig. 5) and refit in the hinge on the opposite side taking care to interpose the tab washer (C - Fig. 5); refit the door taking care to slip the upper hinge rotation pivot into the bush provided on the door for this purpose; refit the middle hinge (Fig. 6) in its new position on the opposite side (remove the plastic plugs from the screw holes of the new hinge location and refit them in the holes on the opposite side); refit the lower door.

Remove the snap-on base (B - Fig. 4); take off the lower hinge (C - Fig. 4) and refit it on the opposite side; remove the slit covering plug from the base (D - Fig. 4) and refit it in the slit on the opposite side; refit the base (B - Fig. 4), then screw the door rotation pivot (A - Fig. 4) back into the lower hinge placed in its new location.

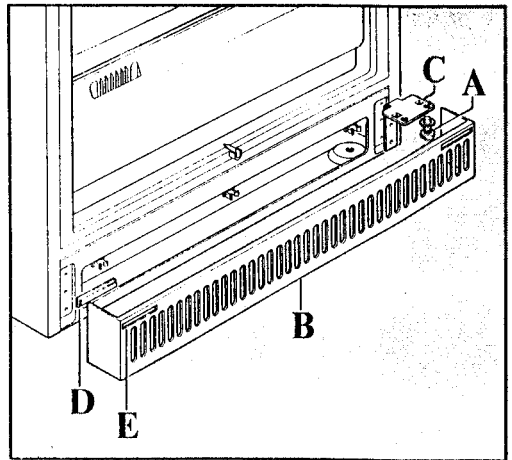

fig. 4

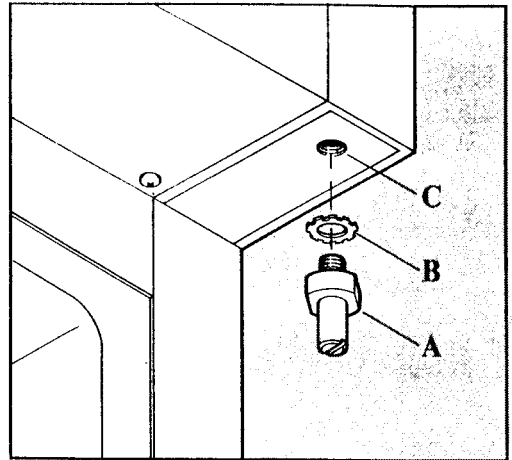

fig. 5

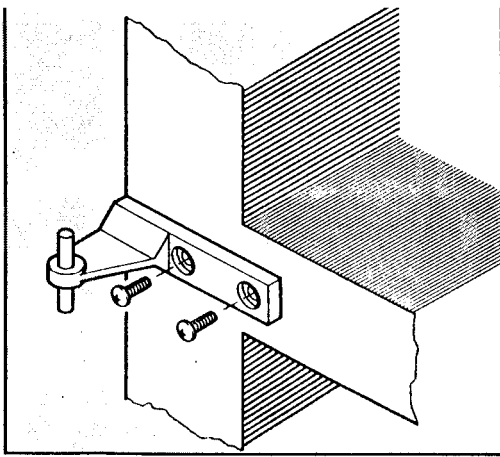

fig. 6

important

The middle hinge (which can be displaced horizontally by about 3 mm) is designed to allow perfect alignment of the two doors; this can easily be attained by going through the following steps:

- Loosen the two screws fixing the hinge to the cabinet.
- Slightly adjust the hinge until perfect alignment of the doors is obtained, then fix the hinge in its new position.

b. Upper and lower door handles

Remove the handle by unscrewing the two fastening screws (Fig. 7); refit the two screws in the same locations; refit the handle upside-down on the opposite side of the door by means of the pre-fitted screws.

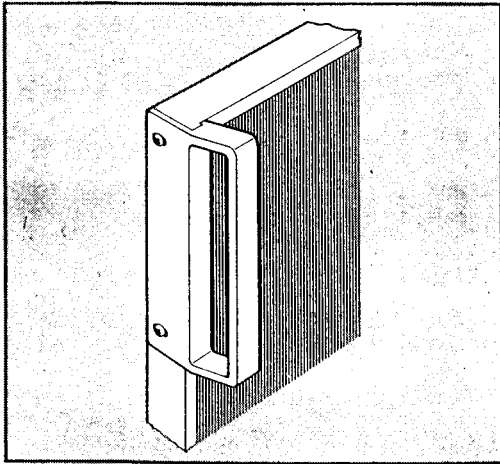

fig. 7

C. Checking the magnetic door seal for airtightness

After returning the refrigerator to an upright position, check by opening and closing the door several times that the rubber seal around the door is not warped.

If any defect is detected, lay down the appliance again, loosen the screws of the top and bottom hinge, and adjust the seal after slightly raising the door and then retighten the screws of the two hinges.

Airtightness of the magnetic seal can be verified by inserting a thin sheet of paper (for instance, from an exercise-book) between the seal and the cabinet, and this sheet of paper should resist traction, i.e.: it should not slide through the door.

If it does slide, adjust the hinges again repeating the above procedure.

d. Fast-freezing compartment door

Whenever door reversal has been carried out, the fast-freezing compartment door should also be reversed to allow best access conditions. For this purpose proceed as follows:

Using a Phillips (crosshead) screwdriver, remove door catch support «A» - Fig. 8; remove the two hinges «B» - Fig. 8 and the relevant door; fit door catch support «A» upside-down, on the opposite side of the inner liner; fit the door and its hinges «B» - Fig. 8 on the opposite side, taking care to turn them upside-down. Check correct operation of the door.

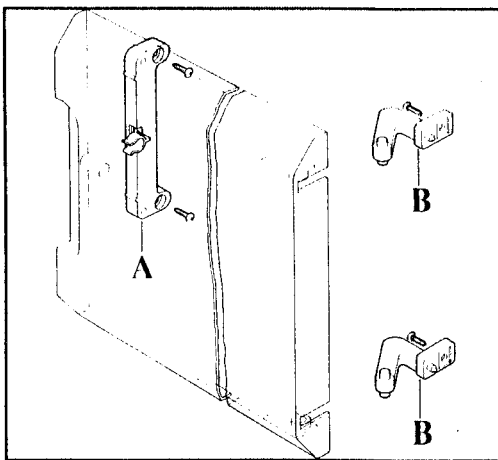

fig. 8

Door panelling directions

To fit the front panel, if so required, go through the following steps:

Take off the removable section of the door frame from the opposite side with respect to the hinges after unscrewing the securing screws (Fig. 9). Unloose, without removing them, all securing screws of the door frame.

Slide in, on the side from which the removable section of the door frame was taken off, the covering panel and push it in all the way.

Fasten again the frame to the door, including the previously removed detachable frame section.

Note: The over-all dimensions of the covering front panel should be 1÷2 mm smaller than those of the door, and the thickness should not exceed 4 mm.

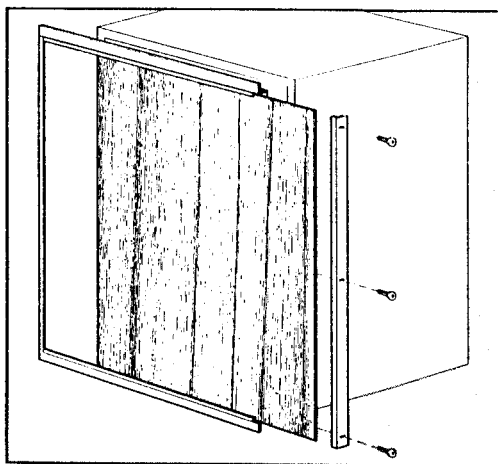

fig. 9

Maintenance

Prior to undertaking any maintenance operation, be sure to unplug the appliance from the wall socket as a safety precaution. Clean out the interior periodically with lukewarm water and bicarbonate of soda, the cabinet exterior with a Silicon wax spray, the condenser and the motor compressor with a brush or a vacuum cleaner. During periods when the appliance is not in use, take the following precautions:

Unplug the freezer from the power supply;

Take out all the foodstuffs contained in the cabinet;

Clean the inside and all accessories; leave the door ajar to facilitate the circulation of air so as to avoid the formation of unpleasant smells.

Servicing

Should service be required for this appliance, contact your local Service Agent but before requesting service the following simple checks may save you inconvenience and expense:

Check that the cabinet light comes on when the door is opened (refrigerator) or that the green light is on (freezer);

Check that the plug is firmly in the wall socket and that all controls are correctly set;

Check that there is an electricity supply to the socket by plugging in another appliance;

If fused plug, replace fuse, plug in and switch on;

Turn thermostat (refrigerator) to colder setting or switch freezer to «**QUICK-FREEZE**» position;

If the motor still does not run, contact your Service Agent.



ZANUSSI STANDARD GUARANTEE CONDITIONS

This guarantee is in addition to your statutory and other legal rights which will not be excluded or in any way diminished by the return of the guarantee card.

We, Zanussi Limited, undertake that if, within twelve months (24 months for TV sets) of the date of the purchase, this ZANUSSI appliance or any part thereof is proved to be defective by reason only of faulty workmanship or materials, we will, at our option, repair or replace the same **FREE OF ANY CHARGE** for labour, materials or carriage on condition that:

—The appliance has been correctly installed and used only on the electricity supply stated on the rating plate.

—The appliance has been used for normal domestic purposes only, and in accordance with the manufacturer's operating and maintenance instructions.

—The appliance has not been serviced, maintained, repaired, taken apart or tampered with by any person not authorised by us.

—The appliance is still in the possession of the original purchaser.

All service work under this guarantee must be undertaken by a Zanussi Network Service Centre (or the Zanussi Authorised TV Service Dealer).

Any appliance or defective part replaced shall become our property.

Exclusions

This guarantee does not cover:

—Damage or calls resulting from transportation, improper use or neglect, the replacement of any light bulbs or removable parts of glass or plastic.

—Costs incurred for calls to put right machines improperly installed or calls to machines outside the UK and the Republic of Ireland.

—Appliances found to be in use within a commercial environment, plus those which are the subject of rental agreements.

—Television receivers - routine adjustment, or poor reception resulting from a source outside of the receiver.



ZANUSSI 5 YEAR COVER CONDITIONS

For a once-only payment you can extend your Standard Guarantee to 5 years. All the conditions and exclusions of the Standard Guarantee apply.

Notes

1. Products supplied as "seconds", refurbished, damaged or shop-soiled are not eligible for Zanussi 5 year cover.
2. The issue of a cover does NOT by virtue of our having done so, nullify the exclusions.
3. The Engineer will need to check the details of your Cover card and may make a charge for his services if it is not presented to him at the time of his call.
4. The date of purchase, or the date of initial payment (deposit) of the appliance will be deemed the date of commencement of cover.
5. Covers issued are not refundable or transferable.

ZANUSSI
The appliance of science

R377

Free Manuals Download Website

<http://myh66.com>

<http://usermanuals.us>

<http://www.somanuals.com>

<http://www.4manuals.cc>

<http://www.manual-lib.com>

<http://www.404manual.com>

<http://www.luxmanual.com>

<http://aubethermostatmanual.com>

Golf course search by state

<http://golfingnear.com>

Email search by domain

<http://emailbydomain.com>

Auto manuals search

<http://auto.somanuals.com>

TV manuals search

<http://tv.somanuals.com>