

# INSTRUCTIONS FOR THE USE AND CARE OF ZANUSSI FRIDGE FREEZER

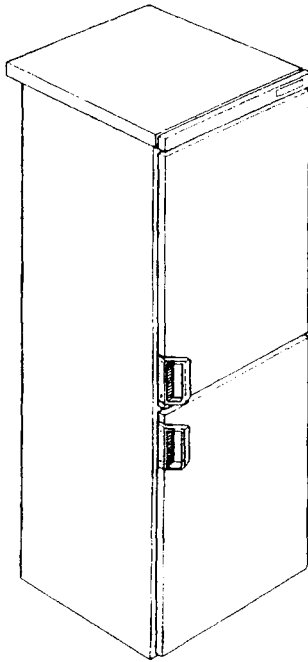

MODEL NO ZF 56/45

**ZANUSSI**  
The appliance of science

It is most important that this instruction book should be retained with the appliance for future reference. Should the appliance be sold or transferred to another owner, or should you move house and leave the appliance, always ensure that the book is supplied with the appliance in order that the new owner can be acquainted with the functioning of the appliance and the relevant warnings.

## Refrigeration Warnings

**THESE WARNINGS ARE PROVIDED IN THE INTEREST OF SAFETY. YOU MUST READ THEM CAREFULLY BEFORE INSTALLING OR USING THE APPLIANCE.**

This appliance is designed to be operated by adults. Children should not be allowed to tamper with the controls or play with the product.

Any electrical work required to install this appliance should be carried out by a qualified electrician or competent person.

This product should be serviced by an authorised Zanussi Network Service Centre, and only genuine Zanussi spare parts should be used.

It is dangerous to alter the specifications or modify this product in any way.

Care must be taken to ensure that the appliance does not stand on the electrical supply cable.

Zanussi domestic refrigerators and fridge/freezers are designed to be used specifically for the storage of edible foodstuffs only.

Frozen food must not be re-frozen once it has been thawed out.

Manufacturers' storage recommendations should be strictly adhered to. Refer to relevant instructions.

There are working parts in this product which heat up. Always ensure that there is adequate ventilation as a failure to do this will result in component failure and possible food loss. See installation instructions.

Parts which heat up should not be exposed. Wherever possible the back of the product should be against a wall.

Before any cleaning or maintenance work is carried out, be sure to switch off the appliance and unplug.

The inner lining of the appliance consists of channels through which the refrigerant passes. If this should be punctured this would damage the appliance beyond repair and cause food loss. **DO NOT USE SHARP INSTRUMENTS** to scrape off frost or ice. Frost may be removed by using the scraper provided. Under no circumstances should solid ice be forced off the liner. Solid ice should be allowed to thaw when defrosting the appliance. See defrost instructions.

The appliance should be left for 2 hours after installation before it is turned on in order to allow the refrigerant to settle.

Do not place carbonated or fizzy drinks in the freezer as it creates pressure on the container, which may cause it to explode, resulting in damage to the appliance.

This appliance is heavy. Care should be taken when moving it.

Ice lollies can cause frost burns if consumed straight from the freezer.

Under no circumstances should you attempt to repair the appliance yourself. Repairs carried out by inexperienced persons may cause injury or more serious malfunctioning. Refer to your local Zanussi Network Centre, and always insist on genuine Zanussi spare parts.

---

# Contents

---

Page 6	Getting to know your machine
Page 7	Installation
Page 9	Using your machine
Page 9	The fridge compartment
Page 12	The freezer compartment
Page 15	Looking after your machine
Page 19	Door reversal
Page 21	Servicing
Page 22	ZANUSSI guarantee
Page 23	ZANUSSI 5 year cover

Please note that the specifications of your appliance may differ slightly from those shown in this booklet.

---

# Specifications

ZF 56/45

---

## Dimensions:

Height	166.0cm (65.4ins)
Width	55.0cm (21.7ins)
Depth	60.0cm (23.6ins)

## Capacity:

Gross fridge	160 litres 5.6cu ft
Freezer	125 litres 4.4cu ft
Net fridge	156 litres 5.5cu ft
Freezer	104 litres 4.2cu ft

## Star rating

4

---

Power Absorbed	190W
Voltage	220/240V
Frequency	50Hz
Average Daily Units of Electricity	1.8kWh

---

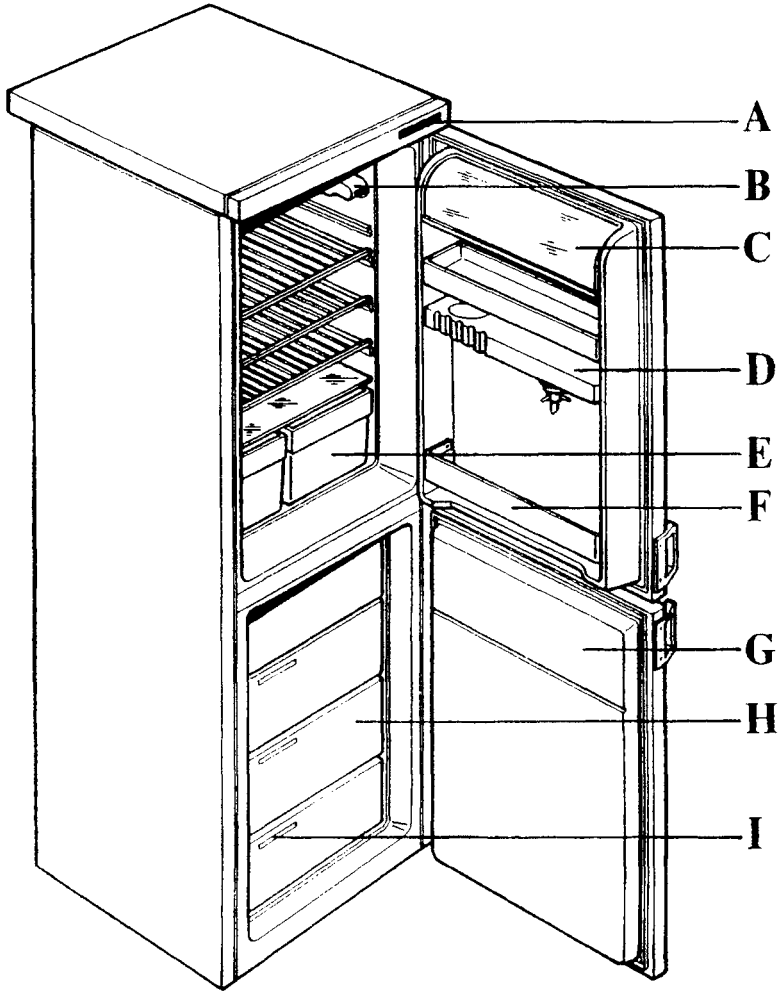

- A** Freezer controls
- B** Interior light/Thermostat control
- C** Dairy compartment
- D** Drink dispenser
- E** Salad crispers
- F** Storage shelf with bottle grippers
- G** Produce storage guide
- H** Four star freezer compartment
- I** Produce storage cards

# Getting to know your machine

## A. Freezer controls (Fig. 1)

Incorporates a fast freeze switch and light (A & B), mains-on light (C), temperature warning light (D) and thermostat control (E).

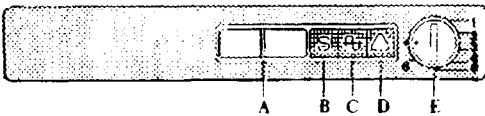

Fig. 1

## B. Interior light/thermostat control

The interior light operates automatically when the door is opened and closed. The thermostat control allows adjustment of the temperature in the refrigerator to accommodate seasonal changes.

## C. Dairy compartment

Separate storage compartment for dairy products to prevent tainting.

## D. Drink dispenser

A container for cooling drinks with an «optic». Removable for easy cleaning and filling, it can be used to store drinks such as water, squash drinks or wine.

## E. Salad crispers

Helps to keep salad produce fresh.

## F. Storage shelf with bottle grippers

Prevents accidental spills.

## G. Produce storage guide

Quick, easy to read guide to aid the user with recommended storage times for frozen foods.

## H. Four star freezer compartment

The freezer is suitable for long term storage of commercially frozen foods marked with the symbol (\*\*\*) up to 3 months, and for freezing fresh foods.

## I. Produce storage cards

Write on, wipe off cards for recording what has been stored in the freezer and when.

# Installation

## WARNING

**IF YOU ARE DISCARDING AN OLD APPLIANCE THAT HAS A LOCK OR CATCH ON THE DOOR, PLEASE ENSURE THAT IT IS MADE UNUSABLE TO PREVENT YOUNG CHILDREN BEING TRAPPED INSIDE.**

Depending upon the position which you choose for your appliance, you may wish to reverse the way in which the door opens. To do this, refer to instructions on page 19.

For this appliance to work efficiently, it should be located away from heat sources, e.g. cookers, radiators, boilers, direct sunlight etc. This also includes locations or rooms where the ambient temperature reaches above 32 degrees C or drops below 16 degrees (e.g. conservatories).

You should also ensure that air can circulate freely around the back and the top of the cabinet. There must also be at least 50mm (2") distance between the top of the cabinet and any overhanging kitchen furniture. Ideally, the appliance should not be positioned beneath overhanging furniture. There should also be a gap of 25mm either side of the appliance. Do not obstruct the space underneath. The back of the cabinet may be placed close to the wall but must not touch it. DO NOT install in places with restricted ventilation.

Adjust the level of the appliance by screwing out the adjustable foot, or feet, at the bottom of the cabinet using your fingers or a spanner. (see fig. 2). Make sure that the cabinet is upright.

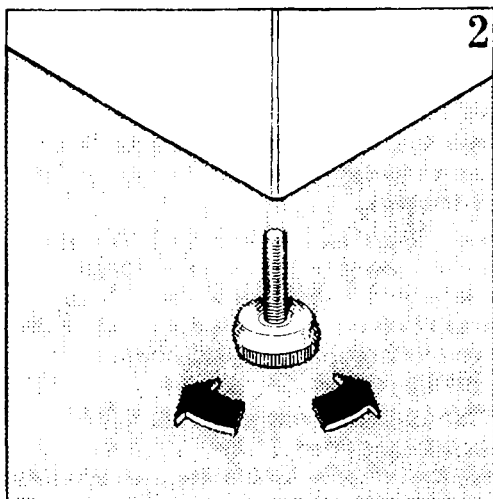

---

# The electrical connections

## WARNING

**THIS APPLIANCE MUST  
BE EARTHED.**

The manufacturer declines any liability should this safety measure not be observed.

If the plug that is fitted to your appliance is not suitable for your socket outlet, it must be cut off and the appropriate plug fitted.

The cut off plug should be disposed of to prevent the hazard of electric shocks in case it should be plugged into a 13 Amp socket in another part of your home.

## IMPORTANT

The wires in the mains lead are coloured in accordance with the following code:

**GREEN AND YELLOW - EARTH  
BLUE - NEUTRAL  
BROWN - LIVE**

If you fit your own plug the colours of the wires in the mains lead of your appliance may not correspond with the markings identifying the terminals in your plug, this is what you have to do:

Connect the green and yellow (earth) wire to the terminal in the plug which is marked with the letter «E» or the earth symbol  $\perp$ , or coloured green, or coloured green and yellow.

Connect the blue (neutral) wire to the terminal in the plug which is marked with the letter «N» or coloured black.

Connect the brown (live) wire to the terminal in the plug with the letter «L» or coloured red.

The plug moulded onto the cord incorporates a fuse, for replacement, use a 13 Amp BS1362 fuse. Only ASTA approved fuses should be used.

The fuse cover/carrier colour is the one shown by the coloured insert at the base of the plug.

The plug must not be used if the fuse cover/carrier is lost. A replacement cover/carrier must be obtained from Zanussi Service Agents whose addresses are listed on the attached «Zanussi Service Agents Nationwide».

**This appliance complies with E.E.C.  
directive number 82/499 of 7.6.82  
relative to radio interference suppression.**



---

# Using your machine

## **Before Using:**

Remove all securing tapes. Wash the inside of the appliance with lukewarm water and a little bicarbonate of soda (one teaspoonful to 1.2 litres/2 pints water). Do not use soap or detergent as the smell might linger. Dry thoroughly.

To start the cooling system insert the plug into the wall socket, switch on.

## **The fridge compartment**

Open the fridge door and turn the thermostat knob beyond the «0» (Off) position.

Temperature adjustment is obtained by turning the thermostat knob to the required setting. A medium setting is generally most suitable. However, the internal temperature will be affected by the location, room temperature, the amount of food being stored and the number of times which the door is opened.

Turn the knob clockwise to higher numbers to obtain a lower temperature, and anticlockwise if a less cold temperature is required.

The required temperature inside the fridge compartment is from 0° C to 7° C (32° F to 45° F).

To obtain the best results from the refrigerator, neither hot food nor liquids which may evaporate, should be placed in the refrigerator.

Cover all foods, particularly those foods with a strong aroma.

Do not pack the fridge too tightly or cover shelves with paper or card so as not to obstruct the free circulation of air.

Place meat to be stored in an airtight box. Meat can only be stored safely in this way for one or two days at the most.

Cooked foods should be well covered. Fruit and vegetables should be thoroughly cleaned and placed in the salad drawers.

Butter and cheese should be placed in special airtight containers or wrapped in foil or polythene bags to exclude as much air as possible.

Milk bottles should have a cap and should be stored in the bottle rack on the door.

# Suggested maximum storage times

Type of food	Storage time
<b>Uncooked fresh meat</b>	
Poultry, beef and lamb	3 - 5 days
Pork	2 - 4 days
Sausages	3 days
Mince and offal	1 - 2 days
<b>Cooked meat</b>	
Ham, sliced meat	2 - 3 days
Pies	1 day
Casseroles and pate	2 days
<b>Bacon</b>	1 week
<b>Dairy produce</b>	
Milk	2 - 3 days
Cream	1 week
Butter	3 - 4 weeks
Hard cheese	3 - 4 weeks
Soft cheese	1 week
<b>Vegetables and salads</b>	1 week

## **Fruit**

Storage times will vary according to the type of food and how fresh it is when put into the fridge compartment, but no food should be stored for longer than the time stated.

# Drink dispenser

The container for cooling drinks (fig. 3) is located in the door of the fridge. It is easily removed from its runners for filling and cleaning by pulling sharply outwards. Remove the clip on lid to fill.

To pour a drink, press a glass upwards against the tap arms. To stop the flow of liquid remove the glass.

If using the dispenser, we recommend that you rinse it several times with hot water. For a thorough cleaning of the container add a spoonful of bicarbonate of soda to the rinsing water. Push the dispenser tap on and off several times to allow sugar deposits from soft drinks or wines to dissolve, or alternatively remove for cleaning by unscrewing in an anticlockwise direction. Empty the container and rinse thoroughly with clean water.

If using the dispenser to store fresh fruit juice, particular attention should be paid to the manufacturers storage instructions. It is also advisable to clean the dispenser thoroughly between every filling, using a solution of sterilising fluid.

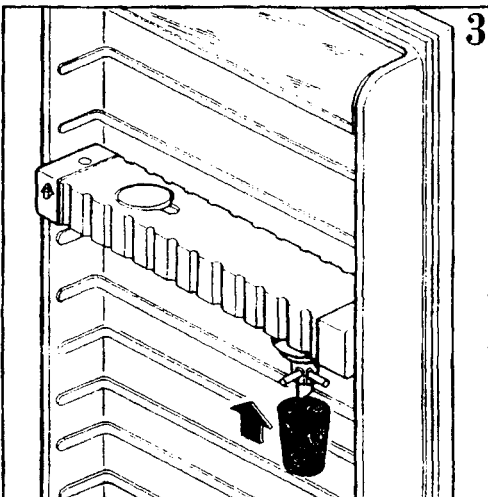

---

# The freezer compartment

The four star freezer compartment is suitable for storage of commercially frozen food, marked with the symbol . The temperature reached of -18°C is suitable for long term storage of frozen foods; this means up to three months unless otherwise stated by the manufacturer. It is also suitable for freezing fresh foods.

Do not exceed the storage times shown by the manufacturer on the commercially frozen food packets.

## Temperature control

The temperature within the freezer is controlled by the thermostat situated at the top of the fridge freezer unit (see Fig. 1).

To operate the freezer proceed as follows:

Plug the appliance into the wall socket and turn the thermostat control «E» beyond the «0» position. The pilot lamp «C» will light up to show that the appliance is working. When you first start the freezer, we suggest that you turn the thermostat control «E» to a medium setting. For easier turning of this control, use a small coin.

The internal temperature of the freezer is automatically adjusted by the thermostat to ensure safe storage of the food. However, if the appliance is working in unfavourable room conditions such as poor ventilation, high temperature and frequent door openings, it may be necessary to select a more suitable setting.

To obtain a lower temperature, turn the thermostat control (E) to the higher numbers; to obtain a higher temperature turn the control to the lower numbers.

## Warning light

If the temperature warning light (D) lights up, it indicates that the temperature within the freezer has reached a level where the safe storage of food is no longer ensured.

When the fridge freezer is first switched on, the warning light will stay on until the temperature has dropped to a safe level for the storage of frozen food.

## Frozen food storage

Your freezer compartment has the following storage capacity:

Net storage volume: 104 litres.

**WE ADVISE YOU TO RUN YOUR NEW FREEZER FOR A DAY BEFORE STORING FROZEN FOODS.**

### **Freezing fresh foods**

In any 24 hours you can freeze up to 10kg (22lbs).

Slide the fast freeze switch (A) to the left to position «S» about 2-3 hours before you want to freeze your food. The fast freeze light will come on (B). After the time has elapsed place the food to be frozen in the top compartment of the freezer as this is the coldest part.

Only freeze top quality, fresh and thoroughly cleaned foodstuffs. Do not allow fresh food to touch food which is already frozen. During the freezing process ensure that the freezer door remains closed.

Once the food is completely frozen, (which will take up to 24 hours depending on the amount), return the Fast Freeze switch (A) to the off position, thus covering the fast freeze light (B).

### **Attention**

Do not put carbonated liquids (fizzy drinks) in the freezer compartment.

Water ices, if consumed immediately after removal from the freezer, can possibly result in a low temperature skin burn.

If there is a power failure during the storage of frozen food, do not open the door during the whole time of the failure. If the freezer is fully loaded, the frozen food will not be affected if the power cut is of short duration, otherwise, it is recommended to consume the food within a very short time.

### **Ice making**

Fill the ice tray with water to the top of each ice cube compartment, and place it in the freezer compartment. To release the ice cubes, twist the tray along its length.

### **Thawing**

Deep frozen or frozen food, prior to being used, can be thawed in the fridge or at room temperature depending on the time available. Small food items may even be cooked from frozen; in this case cooking will take longer.

Any frozen food which is allowed to thaw accidentally should either be eaten as soon as possible or thrown away. Alternatively, if the food is uncooked and has not been completely defrosted it can be cooked and then refrozen.

**DEFROSTED COOKED FOOD MUST NEVER BE REFROZEN.**

---

# Important points to remember

## DO...

- Adjust the level of your fridge before loading it with food (see page 6).
- Cover or wrap liquids and foods, particularly those with strong odours.
- Put vegetables and salads in the salad drawer, in plastic bags.
- Cover melons and pineapples and only store for short periods.
- Rotate stocks of frozen foods; date markings will help with this.
- Leave the door ajar when the fridge freezer is not in use.

## DON'T...

- Obstruct air circulation in the fridge by tightly packing stored items.
- Put hot food in the fridge.
- Let food or containers touch the refrigerator cooling plate.
- Store bananas in the fridge.
- Use a sharp instrument to hasten defrosting or remove ice trays.

# Looking after your machine

## Defrosting

The fridge compartment is automatically defrosted.

Frost is automatically eliminated from the cooling plate at the back of the fridge compartment every time the motor compressor stops.

The defrost water drains out through a trough into a special container on the back of the appliance where it evaporates.

The defrost water drain hole should be cleaned at regular intervals. To do this, use either a straw, pipe cleaner or thin, flexible wire (e.g. net curtain wire without the end hooks) and insert it into the drain hole to a maximum of 6".

The freezer compartment however, will become progressively covered with frost. This frost, which acts as an insulator and thus prevents the cold from reaching the food, should be removed whenever the frost exceeds 5mm (1/4 inch).

**NEVER USE A SHARP METAL TOOL TO SCRAPE OFF FROST FROM THE INTERIOR AS YOU COULD DAMAGE IT.**

The frost should be removed with the special plastic scraper provided.

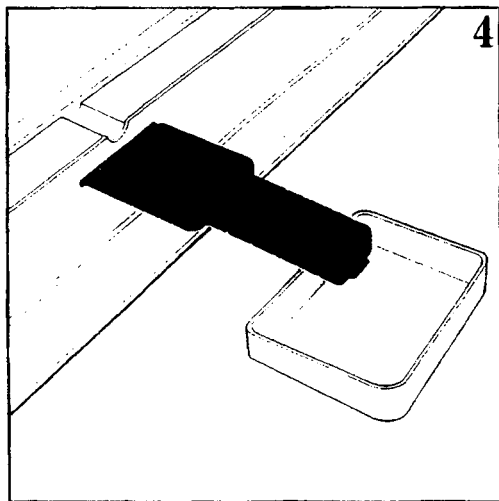

To carry out complete defrosting of the freezer, proceed as follows:  
**wrap frozen food in several layers of newspaper and place the food packages in a cool place.**

**Important**

**A temperature rise of the frozen food packs during defrosting may shorten their storage life.**

Remove any stored food from the compartment and wrap well.

Switch off, and remove the plug from the wall socket, or turn the thermostat to the «0» setting.

Leave the freezer door open, and the door to the fast freeze compartment.

Introduce the plastic scraper in the appropriate seating as shown in figure 4, place underneath a basin to collect the defrost water.

When defrosting is completed, dry the interior thoroughly.

Hook once again the plastic scraper in the appropriate seating on the basket (fig. 5).

Replace the plug in the socket, and after letting the appliance run until the warning light switches off, replace the previously removed food.

**Important**

**A temperature rise of the frozen food packs during defrosting may shorten their storage life.**

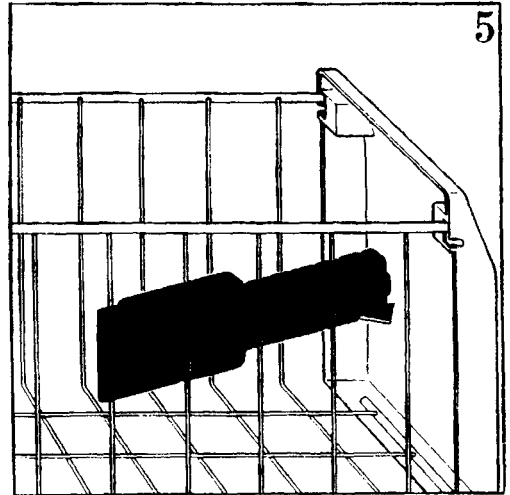



---

# Cleaning

The most suitable time to clean your fridge freezer would be after defrosting before turning the appliance back on again.

Clean out the interior with a clean cloth wrung out in a solution of warm water and bicarbonate of soda (1 teaspoon to 600ml/1 pint of water).

**NEVER USE DETERGENTS, OR ABRASIVE POWDERS, HIGHLY PERFUMED CLEANING MATERIALS OR WAX POLISHES TO CLEAN THE INTERIOR OF THE FRIDGE AS THESE WILL DAMAGE THE SURFACES AND LEAVE A STRONG SMELL.**

The outside should be occasionally dusted or wiped over with a damp cloth and a small amount of detergent, but not the door seal which should be cleaned with the bicarbonate of soda solution.

A small amount of wax polish, or silicone wax spray can be used to maintain the gloss finish of the outside cabinet.

The motor compressor and condenser should be cleaned of dust occasionally using a brush or vacuum cleaner.

Occasionally strong smelling foods may leave the fridge with a slight odour. Placing a small dish of bicarbonate of soda solution should slowly absorb these smells.

During periods when the appliance is not in use, take the following precautions:

Unplug the fridge freezer from the power supply.

Remove all foodstuffs from the fridge freezer.

Clean the interior and all accessories; leaving the interior of the cabinet open to prevent unpleasant odours lingering in the appliance.

### **Replacing the interior light bulb**

Should the interior light in the fridge fail to work, first switch off and pull out the mains plug, and then replace the bulb as follows:

Remove the bulb housing cover, situated underneath the light/thermostat mechanism, by unscrewing the screw and by sliding it out (see Fig. 6).

Unscrew the lightbulb by turning in an anticlockwise direction.

Replace with a 10W bulb.

Replace the bulb housing cover by sliding back in.

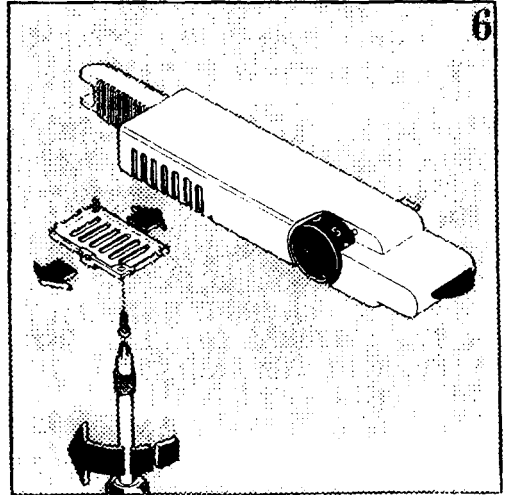

# Door reversal (Fig. 7)

BEFORE CARRYING OUT THE INSTRUCTIONS GIVEN BELOW FOR REVERSING THE DOOR HINGE FROM RIGHT TO LEFT, SWITCH THE FRIDGE FREEZER OFF AND REMOVE THE PLUG FROM THE WALL SOCKET.

**1**

Gently lay the fridge freezer on its back with the top held away from the floor by 5-8cm (2-3 inches) of packing.

**2**

Remove the bottom hinge (1) by unscrewing the two screws. Be sure to keep the plastic washer safe.

**3**

Remove the freezer door by opening the door and pulling gently downwards to release it from the middle hinge/pin (2).

**4**

Remove the lower middle hinge/pin (2) and refit it on the opposite side.

**5**

Remove the upper middle hinge/pin (3) by unscrewing the screw.

**6**

Remove the fridge door by opening the door and pulling gently downwards to remove it from the top hinge pin (4).

**7**

Unscrew the top hinge pin (4) and replace it in the opposite hole on the left hand side.

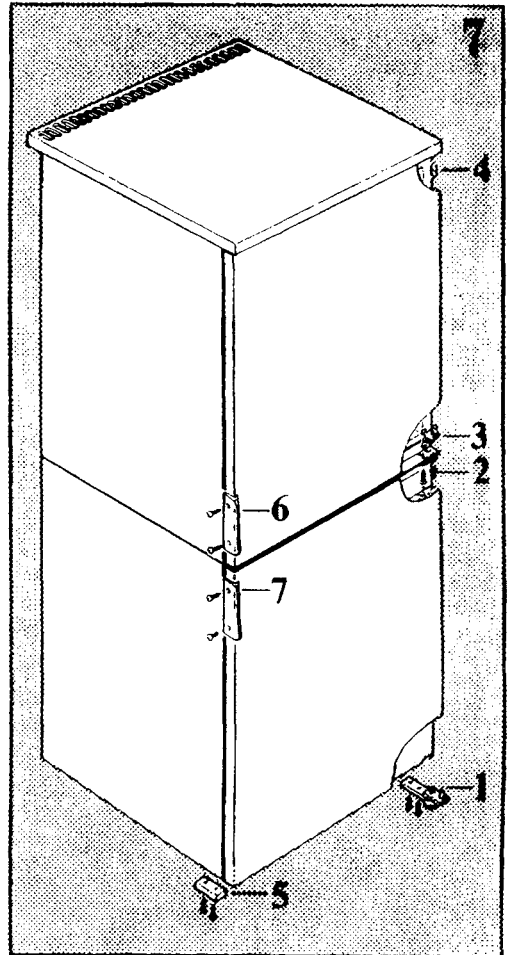

---

**8**

Refit the fridge door and the upper middle hinge pin (3) to the left hand side of the appliance.

**9**

Unscrew the foot (5) at the base of the appliance and refit it on the opposite side.

**10**

Refit the freezer door and the bottom hinge (1) with washer to the left hand side.

**11**

Remove the two door handles (6 & 7) by unscrewing them and refit on the opposite side by removing the plastic plugs from the fixing holes and fitting them in the vacated holes on the opposite side. (Protect the paintwork with masking tape).

---

# Servicing

If, having followed these instructions carefully, your machine fails to work properly, contact your local Zanussi Service Network, whose details can be found under «Z» in your local telephone directory. Before you do that though it is worth making a few simple checks yourself.

Is the plug firmly connected to the wall socket and the socket switched on? Check the power supply by plugging in another appliance.

Check that there is not a power failure. Switch on the house lights.

Is the fuse in the plug intact and are the wires in the mains lead correctly connected to the plug? (see page 7 for Electrical Connections).

Have you turned the thermostat to the correct setting?

Has the door been left open causing the temperature to rise?

If there are water drops on the bottom of the fridge compartment, check that the defrost water drain is not obstructed.

**IN-GUARANTEE CUSTOMERS SHOULD ENSURE THAT THE ABOVE CHECKS HAVE BEEN MADE AS THE ENGINEER WILL MAKE A CHARGE IF THE FAULT IS NOT A MECHANICAL OR ELECTRICAL BREAKDOWN.**

**\*PLEASE NOTE THAT PROOF OF PURCHASE IS REQUIRED FOR ANY IN-GUARANTEE SERVICE CALLS.**

---

# Peace of mind for twelve months

## ZANUSSI STANDARD GUARANTEE CONDITIONS

This guarantee is in addition to your statutory and other legal rights which will not be excluded or in any way diminished by the return of this guarantee card.

We, Zanussi Ltd, undertake that if, within twelve months of the date of the purchase, this ZANUSSI appliance or any part thereof is proved to be defective by reason only of faulty workmanship or materials, we will, at our option, repair or replace the same **FREE OF ANY CHARGE** for labour, materials or carriage on condition that:

The appliance has been correctly installed and used only on the electricity supply stated on the rating plate.

- The appliance has been used for normal domestic purposes only, and in accordance with the manufacturer's operating and maintenance instructions.
- The appliance has not been serviced, maintained, repaired, taken apart or tampered with by any person not authorised by us.
- The appliance is still in the possession of the original purchaser.

All service work under this guarantee must be undertaken by a Zanussi Network Service Centre.

Any appliance or defective part replaced shall become our property.

## Exclusions

- Damage or calls resulting from transportation, improper use or neglect, the replacement of any light bulbs or removable parts of glass or plastic.
- Costs incurred for calls to put right machines improperly installed or calls to machines outside the UK and the Republic of Ireland.
- Appliances found to be in use within a commercial environment, plus those which are the subject of rental agreements.
- Television receivers-routine adjustment, or poor reception resulting from a source outside of the receiver.

---

## or five years

### ZANUSSI 5 YEAR COVER CONDITIONS

For a once-only payment you can extend your Standard Guarantee to 5 years. All the conditions and exclusions of the Standard Guarantee apply.

#### Notes

1. Products supplied as «seconds», refurbished, damaged or shop-soiled are not eligible for Zanussi 5 Year Cover.
2. The issue of a cover does NOT by virtue of our having done so, nullify the exclusions.

3. The Engineer will need to check the details of your Cover card and may make a charge for his services if it is not presented to him at the time of his call.

4. The date of purchase, or the date of initial payment (deposit) of the appliance will be deemed the date of commencement of cover.

5. Covers issued are not refundable or transferable.

---

## Guarantee Record

Appliance purchased from \_\_\_\_\_ on \_\_\_\_\_  
Guarantee card no \_\_\_\_\_ Model no \_\_\_\_\_  
Serial no \_\_\_\_\_ (These details may be  
Your name \_\_\_\_\_ taken from your  
Address \_\_\_\_\_ Guarantee Record Card)

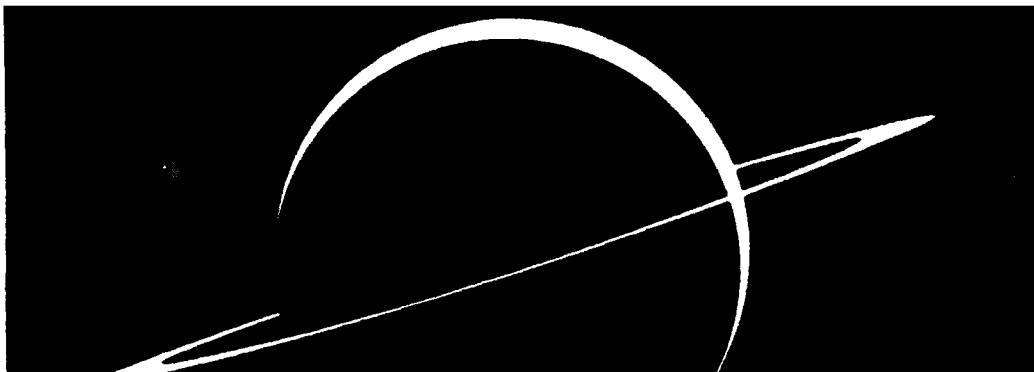

# ZANUSSI

The appliance of science

IAZ International (UK) Ltd., Zanussi House, Newbury

The information in this manual is correct at time of going to press.

Zanussi reserve the right to alter specifications without notice.

Download from [www.Sofmanualse.com](http://www.Sofmanualse.com). All Manuals Search And Download.



## Free Manuals Download Website

<http://myh66.com>

<http://usermanuals.us>

<http://www.somanuals.com>

<http://www.4manuals.cc>

<http://www.manual-lib.com>

<http://www.404manual.com>

<http://www.luxmanual.com>

<http://aubethermostatmanual.com>

Golf course search by state

<http://golfingnear.com>

Email search by domain

<http://emailbydomain.com>

Auto manuals search

<http://auto.somanuals.com>

TV manuals search

<http://tv.somanuals.com>