

RANGE COMPOSITION

N 900: a range of over 150 models for the professional caterer designed to guarantee the highest level of performance, reliability, energy saving, safety standards and ergonomic operation. These concepts are reflected in the total modularity of the range that ensures innumerable configurations, either free-standing, bridged or cantilever. N900 demonstrates how advanced technology can satisfy the needs of the professional caterer. The models detailed in this sheet are two fry tops in gas and electric version on static oven.



Model 200224

N 900

FULL MOD. FRY TOPS ON OVEN-THERMOSTATIC ZANUSSI PROFESSIONAL

FUNCTIONAL AND CONSTRUCTION FEATURES

- ◆ Stainless steel burner with a self-stabilizing flame. The burner has 4 branches with 8 flame lines (gas models).
- ◆ Incoloy heating elements positioned under the cooking plate (electric models)
- ◆ Gas static oven (on model NRFG800) with stainless steel burners, self-stabilizing flame positioned beneath the base plate and a thermostat adjustable from 120° to 280°C
- ◆ Electric static oven (on model NRFE800) with separate thermostats for top and bottom elements. Oven thermostat with temperature markings in °C adjustable from 120° to 280°C and power of 6 KW.
- ◆ Safety thermostat on models with thermostatic control (temperature markings in °C). Piezo ignition.
- ◆ Deep drawn worktop in 20/10 stainless steel. Front and side panels in stainless steel with Scotch Brite finish.
- ◆ All models have right-angled side edges to allow flush fitting joints between units eliminating gaps and possible dirt traps. The new built-in design (not valid for gas cock models) avoids fat infiltration behind the appliance improving hygienic condition.

- ◆ Cooking surface with rounded corners and removable higher splashback, available in mild steel (smooth or ribbed surface) or mild steel coated with a layer of hard polished chrome (only smooth) for optimum grilling results.
- ◆ On the cooking surface there is a large drain hole to drain fat into a 3-lt collector placed under the cooking area.
- ◆ Main connections can be via the base of the unit.
- ◆ All models provided with service duct to facilitate installation.
- ◆ All gas appliances are supplied for use with natural gas, with LPG conversion jets supplied as standard.
- ◆ Very quick heat-up time to maximum temperature.

- ◆ The special design of the control knob system guarantees against water infiltration.
- ◆ Removable splashback in stainless steel and scrapers with smooth/ribbed blades included as standard.
- ◆ IPX5 water protection.

* In accordance with CE regulations for gas models belonging to Class B11 (power over 14 kW), it is necessary to install a chimney (if installed under a hood) or chimney and draft diverter if the waste gases are vented directly outside.

TECHNICAL DATA		
CHARACTERISTICS	MODELS	
	NRG8MMO 200224	NRE8MMO 200225
Power supply	Gas	Electric
External dimensions - mm		
width	800	800
depth	900	900
height	850	850
height adjustment	50	50
Sloped cooking surface	●	●
Thermostatic valve	●	●
Net weight - kg.	171	171
Supply voltage		400 V, 3N, 50/60
INCLUDED ACCESSORIES		
2/1 GN CHROME GRID	1	1
SCRAPER FOR RIBBED PLATE FRY TOP	1	1
SCRAPER FOR SMOOTH PLATE FRY TOP	1	1

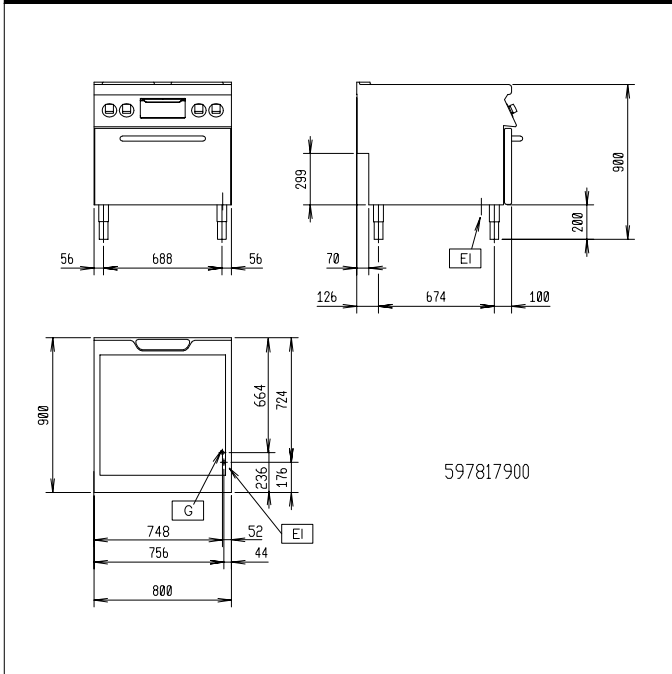
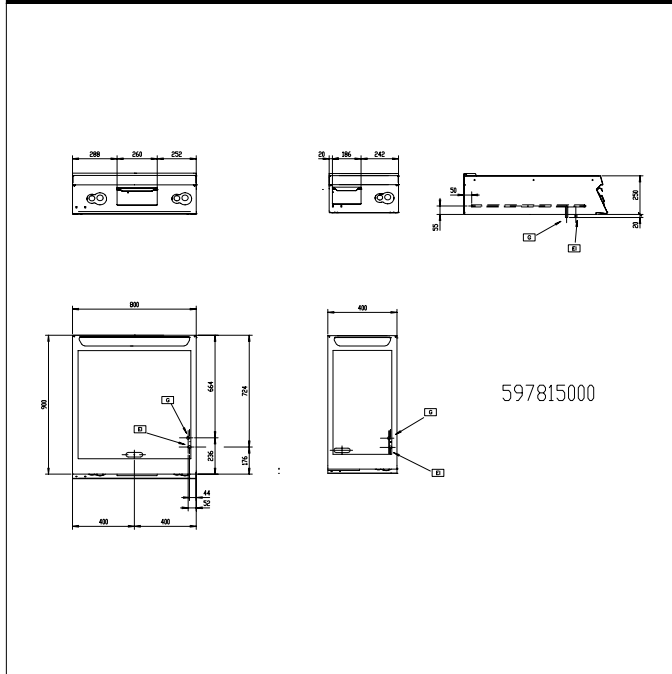

LEGEND

	NRG8SMMO 200224	NRE8SMMO 200225
EI - Electrical connection		400 V, 3N, 50/60
G - Gas connection	1/2"	

OPTIONAL ACCESSORIES

ACCESSORIES	MODELS	
	NRG8SMMO 200224	NRE8SMMO 200225
2 PANELS FOR SERVICE DUCT (BACK TO BACK)	206202	206202
2 PANELS FOR SERVICE DUCT (SINGLE INST.)	206181	206181
2 SIDE COVERING PANELS FOR TOP-D=900MM	206278	206278
2 SIDE COVERING PANELS H=700 D=900	206134	206134
2 SIDE KICKING STRIPS	206180	206180
2 SIDE KICKING STRIPS F.CONCRETE INSTAL.	206157	206157
2/1 GN CHROME GRID	164250	164250
4 FEET FOR CONCRETE INSTALLATION	206210	206210
4 WHEELS (2 WITH BRAKE)	206188	206188
DRAUGHT DIVERTER WITH 120 MM DIAMETER	206126	206126
DRAUGHT DIVERTER WITH 150 MM DIAMETER	206132	206132
FLANGED FEET KIT	206136	206136
FLUE CONDENSER FOR 1 MODULE DIAM.150MM	206156	206156
FLUE CONDENSER FOR 1/2 MOD. DIAM.120MM	206155	206155
FRONT.KICK.STRIP F.CONCRETE INST.1000 MM	206150	206150
FRONT.KICK.STRIP F.CONCRETE INST.1200 MM	206151	206151
FRONT.KICK.STRIP F.CONCRETE INST.1600 MM	206152	206152
FRONT.KICK.STRIP F.CONCRETE INST.200 MM	206146	206146
FRONT.KICK.STRIP F.CONCRETE INST.400 MM	206147	206147
FRONT.KICK.STRIP F.CONCRETE INST.800 MM	206148	206148
FRONTAL HANDRAIL 1200 MM	206191	206191
FRONTAL HANDRAIL 1600 MM	206192	206192
FRONTAL HANDRAIL 400 MM	206166	206166
FRONTAL HANDRAIL 800 MM	206167	206167
FRONTAL KICKING STRIP 1000 MM	206177	206177
FRONTAL KICKING STRIP 1200 MM	206178	206178
FRONTAL KICKING STRIP 1600 MM	206179	206179
FRONTAL KICKING STRIP 200 MM	206174	206174
FRONTAL KICKING STRIP 400 MM	206175	206175
FRONTAL KICKING STRIP 800 MM	206176	206176
JUNCTION SEALING KIT	206086	206086
LARGE HANDRAIL(PORTIONING SHELF)400 MM	206185	206185
LARGE HANDRAIL(PORTIONING SHELF)800 MM	206186	206186
MATCHING RING FOR FLUE CONDENSER 150DIAM	206133	206133
PAIR OF COVERING STRIPS FOR END ELEMENTS	206234	206234
PRESSURE REGULATOR FOR GAS UNITS	927225	
REAR FLUE UPSTAND FOR LARGE CHIMNEY	206160	
REAR FLUE UPSTAND FOR SMALL CHIMNEY		206159
SCRAPER FOR SMOOTH PLATE FRY TOP		164255
SIDE HANDRAIL-RIGHT/LEFT HAND	164255	164255
SUPPORT FOR "BRIDGE" SYSTEM 1000 MM	206138	206138
SUPPORT FOR "BRIDGE" SYSTEM 1200 MM	206139	206139
SUPPORT FOR "BRIDGE" SYSTEM 1400 MM	206140	206140
SUPPORT FOR "BRIDGE" SYSTEM 1600 MM	206141	206141
SUPPORT FOR "BRIDGE" SYSTEM 400 MM	206154	206154
SUPPORT FOR "BRIDGE" SYSTEM 800 MM	206137	206137
WATER COLUMN EXTENSION FOR 900 LINE	206290	206290
WATER COLUMN WITH SWIVEL ARM	206288	206288
WATER DRAIN FOR FRY TOP FULL MODULE	216153	216153
WATER DRAIN FOR FRY TOP HALF MODULE	206153	206153



www.zanussiprofessional.com

Free Manuals Download Website

<http://myh66.com>

<http://usermanuals.us>

<http://www.somanuals.com>

<http://www.4manuals.cc>

<http://www.manual-lib.com>

<http://www.404manual.com>

<http://www.luxmanual.com>

<http://aubethermostatmanual.com>

Golf course search by state

<http://golfingnear.com>

Email search by domain

<http://emailbydomain.com>

Auto manuals search

<http://auto.somanuals.com>

TV manuals search

<http://tv.somanuals.com>