

User
information

Built-in oven

ZOB 150

Thank you for selecting our appliance

We wish you lots of enjoyment with your new appliance and we hope that you will consider our brand again when purchasing household appliances.

Please read this user manual carefully and keep it throughout the product life cycle as a reference document. The user manual should be passed on to any future owner of the appliance.

Contents

Warnings and Important Safety Information	5
Description of the appliance	7
Controls	8
Before using the oven for the first time	9
Using the Oven	10
Baking and Roasting Tables	13
Cleaning and Maintenance	15
If something is wrong	18
Technical Data	19
Electrical Connection	20
Instructions fo Building In	21
Guarantee/Customer Service	22
European Guarantee	23

Guide to using the user instructions



Safety instructions



Step by step instructions



Hints and Tips



Environmental Informations



This appliance conforms with the following **ECC Directives**:

- **2006/95** (Low Voltage Directive);
 - **89/336** (EMC Directive);
 - **93/68** (General Directive);
- and subsequent modifications.



Warnings and Important Safety Information

These warnings are provided for the safety of the users and those living with them. So read them carefully before installing and using the appliance.

This will allow you to obtain best performance, avoid improper actions, use the appliance in complete safety and also respect the environment.

If you need assistance, contact our Customer Care Department on 08705 727 727

Installation

- This oven must be installed by qualified personnel to the relevant British Standards.
- This oven is heavy. Take care when moving it.
- Remove all packaging, both inside and outside the oven, before using the oven.
- Do not attempt to modify the oven in any way.
- Do not hang towels, dishcloths or clothes from the oven or its handle.
- Do not use this oven if it is in contact with water and never operate it with wet hands.
- Take great care when heating fats and oils as they will ignite if they become too hot.
- Always use oven gloves to remove and replace food in the oven.

During use

- This oven is intended for domestic cooking only. It is not designed for commercial or industrial purposes.
- Always stand back from the oven when opening the oven door during cooking or at the end of it to allow any build up of steam or heat to release.
- Appliances become very hot with use, and retain their heat for long periods after use. Care should be taken to avoid touching heating elements inside the oven.
- Never line any part of the oven with aluminium foil.
- Do not allow heatproof cooking material, e.g. roasting bags, to come into contact with oven elements.
- Never place plastic or any other material which may melt in or on the oven.
- Do not place sealed cans or aerosols inside the oven. They may explode if they are heated.
- Before cleaning the oven, either turn the power off or pull the mains plug out.
- Ensure that all controls are in the OFF position when not in use.
- Do not leave cookware containing foodstuffs, e.g. fat or oil in or on the oven in case it is inadvertently switched ON.
- When using other electrical appliances, ensure the cable does not come into contact with the hot surfaces of the oven.

People Safety

- This oven is designed to be operated by adults. Do not allow children to play near or with the oven.
- The oven gets hot when it is in use. Children should be kept away until it has cooled.
- This appliance is not intended for use by children or other persons whose physical, sensory or mental capabilities or lack of experience and knowledge prevents them from using the appliance safely without supervision or instruction by a responsible person to ensure that they can use the appliance safely.

Maintenance and Cleaning

- Only clean this oven in accordance with the instructions.
- Always allow the oven to cool down and switch off the electrical supply before carrying out any cleaning or maintenance work.
- The oven should be kept clean at all times. A build-up of fats or other foodstuffs could result in a fire, especially in the grill pan.
- Never use steam or high pressure steam cleaners to clean the appliance.
- Do not use abrasive cleaners or sharp metal scrapers. These can scratch the glass in the oven door, which may result in the shattering of the glass.

Service

- This oven should only be repaired or serviced by an authorised Service Engineer and only genuine approved spare parts should be used.



Environmental Information

- After installation, please dispose of the packaging with due regard to safety and the environment.
- When disposing of an old appliance, make it unusable, by cutting off the cable. Remove any door catches, to prevent small children being trapped inside.



The symbol  on the product or on its packaging indicates that this product may not be treated as household waste. Instead it shall be handed over to the applicable collection point for the recycling of electrical and electronic equipment. By ensuring this product is disposed of correctly, you will help prevent potential negative consequences for the environment and human health, which could otherwise be caused by inappropriate waste handling of this product.

For more detailed information about recycling of this product, please contact your local city office, your household waste disposal service or the shop where you purchased the product.

Always keep these user instructions with the appliance. Should the appliance be passed on to third persons or sold, or if you leave this appliance behind when you move house, it is very important that the new user has access to these user instructions and the accompanying information.

Description of the appliance

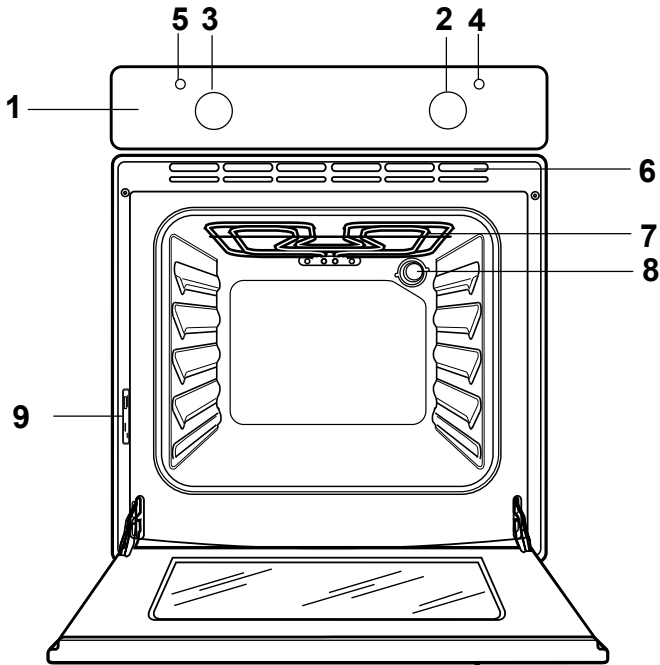



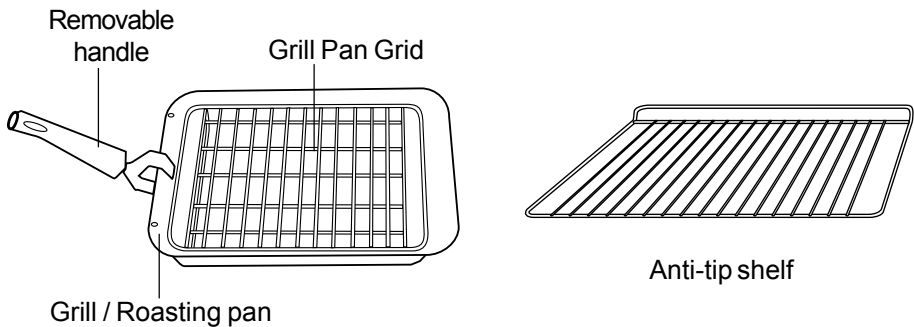

- | | |
|-------------------------------|---------------------------------|
| 1. Control Panel | 5. Thermostat Control Indicator |
| 2. Oven Function Control Knob | 6. Air Vents for Cooling Fan |
| 3. Thermostat Control Knob | 7. Grill |
| 4. Mains On Indicator | 8. Oven light |
| | 9. Rating plate |

Oven accessories



Controls

Oven Function Control Knob

- 0 The oven is off
-  **Conventional cooking** - The heat comes from both the top and bottom element, ensuring even heating inside the oven
-  **Bottom heating element** - The heat comes from the bottom of the oven only
-  **Top heating element** - The heat comes from the top element only (outer section)
-  **Inner grill element only** - Can be used for grilling small quantities
-  **Full Grill** - The full grill element will be on

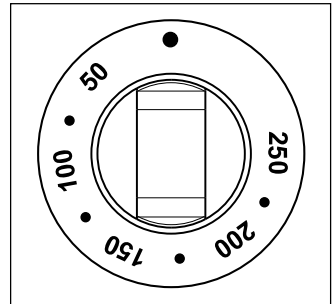
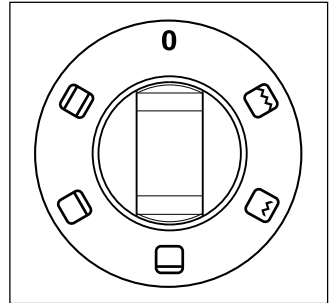

Mains on Indicator

The mains on light will come on when the oven function control knob is set.

Thermostat Control Knob

Turn the thermostat control knob clockwise to select temperatures between 50°C and 250°C.

Thermostat Control Indicator

The thermostat control indicator will come on when the thermostat control knob is turned. The indicator will remain on until the correct temperature is reached. It will then cycle on and off to show the temperature is being maintained.

Safety Thermostat

To prevent dangerous overheating (through incorrect use of the appliance or defective components), the oven is fitted with a safety thermostat, which interrupts the power supply. The oven switches back on again automatically, when the temperature drops.

Should the safety thermostat trigger due to incorrect use of the appliance, it is enough to remedy the error after the oven has cooled down; if on the other hand, the thermostat triggers because of a defective component, please contact Customer Service.

The cooling fan

The oven is provided with a cooling fan, meant to keep the front panel, the knobs and the oven door handle cool. The fan switches on automatically when the oven is activated. Warm air is blown out through the aperture near the oven door handle. The fan switches off when, after cooking, the oven function control knob is set to OFF position **0**.

Before using the oven for the first time

i Remove **all packaging**, both inside and outside the oven, before using the oven.

Before using for the first time, the oven should be heated up without food.

During this time, an unpleasant odour may be emitted. This is absolutely normal. It is caused by manufacturing residues.

Ensure the room is well ventilated.

1. Switch the oven function control knob to conventional cooking .
2. Set the thermostat control knob to 250°C.
4. Open a window for ventilation.
5. Allow the oven to run empty for approximately 45 minutes.

This procedure should be repeated with the full grill  function for approximately 5-10 minutes.

i Then let the oven cool down. Then dampen a soft cloth with warm water and a little mild washing-up liquid and use this to clean the oven cavity.

i Before using for the first time, carefully wash the oven accessories as well.

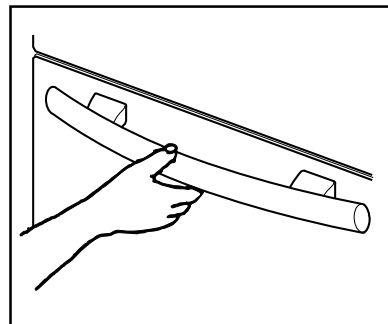

To open the oven door, always hold the handle in the centre.

Using the oven

The oven is supplied with an exclusive system which produces a natural circulation of air and the constant recycling of steam.

This system makes it possible to cook in a steamy environment and keep the dishes soft inside and crusty outside. Moreover, the cooking time and energy consumption are reduced to a minimum. During cooking steam may be produced which can be released when opening the oven door. This is absolutely normal.



However, always stand back from the oven when opening the oven door during cooking or at the end of it to allow any build up of steam or heat to release.



Attention! - Do not place objects on the oven base and do not cover any part of the oven with aluminium foil while cooking, as this could cause a heat build-up which would affect the baking results and damage the oven enamel. Always place pans, heat-resisting pans and aluminium trays on the shelf which has been inserted in the shelf runners. When food is heated, steam is created, like in a kettle. When the steam comes into contact with the glass in the oven door, it condenses and creates water droplets.

To reduce condensation, always preheat the empty oven for 10 minutes.

We recommend you wipe the water droplets away after every cooking process.

Always cook with the oven door closed. Stand clear when opening the drop down oven door. **Do not** allow it to fall open - support the door using the door handle, until it is fully open.

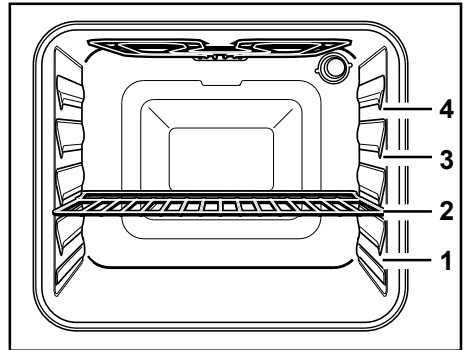

The oven has four shelf levels, and is supplied with one shelf. The shelf positions are counted from the bottom of the oven as shown in the diagram.

It is important that these shelves are correctly positioned as shown in the diagram.

Do not place cookware directly on the oven base.

Conventional Cooking

- The middle shelf position allows for the best heat distribution. To increase base browning simply lower the shelf position. To increase top browning, raise the shelf position.
- The material and finish of the baking trays and dishes used will affect base browning. Enamelware, dark, heavy or non-stick utensils increase base browning, while oven glassware, shiny aluminium or polished steel trays reflect the heat away and give less base browning.
- Always place dishes centrally on the shelf to ensure even browning.
- Stand dishes on suitably sized baking trays to prevent spillage onto the base of the oven and make cleaning easier.

- Do not place dishes, tins or baking trays directly on the oven base as it becomes very hot and damage will occur. When using this setting, heat comes from both the top and bottom elements. This allows you to cook on a single level and is particularly suitable for dishes which require extra base browning such as quiches and flans.

Gratins, lasagnes and hotpots which require extra top browning also cook well in the conventional oven.

How to use the conventional oven

1. Turn the oven function control knob to the required cooking function .
2. Turn the thermostat control knob to the required temperature.

Top oven element only

This function is suitable for finishing cooked dishes, e.g. lasagne, shepherds pie, cauliflower cheese etc.

Bottom oven element only

This function is particularly useful when blind-baking pastry. It may also be used to finish off quiches or flans to ensure the base pastry is cooked through.

 The thermostat control light will remain on until the correct temperature is reached. It will then cycle on and off to show the temperature is being maintained.

Grilling -

- Most foods should be placed on the grid in the grill pan to allow maximum circulation of air and to lift the food out of the fats and juices. Food such as fish, liver and kidneys may be placed directly on the grill pan, if preferred.
- Food should be thoroughly dried before grilling to minimise splashing. Brush lean meats and fish lightly with a little oil or melted butter to

keep them moist during cooking.

- Accompaniments such as tomatoes and mushrooms may be placed underneath the grid when grilling meats
- When toasting bread, we suggest that the top runner position is used.
- The food should be turned over during cooking, as required.

Full Grill Element

1. Turn the oven control function knob on .
2. Turn the thermostat control knob on the required temperature.
3. Adjust the grid and grill pan runner position to allow for different thicknesses of food. Position the food close to the element for faster cooking and further away for more gentle cooking.

Preheat the grill on a full setting for a few minutes before sealing steaks or toasting. Adjust the heat setting and the shelf as necessary, during cooking. During cooking, the cooling fan and the thermostat control light will operate in the same way as described for the fan oven function.

Inner Grill Element

The inner grill provides quick direct heat to the central area of the grill pan. By using the inner grill element for cooking small quantities, it can help to save energy.

1. Turn the oven control function knob on .
2. Turn the thermostat control knob on the required temperature.
3. Adjust the grid and grill pan runner position to allow for different thicknesses of food and follow the instructions for grilling.

The grill element is controlled by the thermostat. During cooking, the grill cycles on and off to prevent overheating.

Hints and Tips

- The middle shelf position allows for the best heat distribution. To increase base browning simply lower the shelf position. To increase top browning, raise the shelf position.
- The material and finish of the baking trays and dishes used will affect base browning. Enamelware, dark, heavy or non-stick utensils increase base browning, while oven glassware, shiny aluminium or polished steel trays reflect the heat away and give less base browning.
- Always place dishes centrally on the shelf to ensure even browning.
- Stand dishes on suitably sized baking trays to prevent spillage onto the base of the oven and make cleaning easier.
- Do not place dishes, tins or baking trays directly on the oven base as it becomes very hot and damage will occur.

On baking:

Cakes and pastries usually require a medium temperature (150°C-200°C) and therefore it is necessary to preheat the oven for about 10 minutes.

Do not open the oven door before 3/4 of the baking time has elapsed.

Shortcrust pastry is baked in a springform tin or on a tray for up to 2/3 of the baking time and then garnished before being fully baked. This further baking time depends on the type and amount of topping or filling. Sponge mixtures must separate with difficulty from the spoon. The baking time would be unnecessarily extended by too much liquid.

If two baking trays with pastries or biscuits are inserted into the oven at the same time, a shelf level must be left free between the trays.

If two baking trays with pastries or biscuits are inserted into the oven at the same time, the trays must be swapped and turned around after about 2/3 of the baking time.

On Roasting:

Do not roast joints smaller than 1 kg. Smaller pieces could dry out when roasting. Dark meat, which is to be well done on the outside but remain medium or rare inside, must be roasted at a higher temperature (200°C-250°C).

White meat, poultry and fish, on the other hand, require a lower temperature (150°C-175°C). The ingredients for a sauce or gravy should only be added to the roasting pan right at the beginning if the cooking time is short. Otherwise add them in the last half hour.

You can use a spoon to test whether the meat is cooked: if it cannot be depressed, it is cooked through. Roast beef and fillet, which is to remain pink inside, must be roasted at a higher temperature in a shorter time.

If cooking meat directly on the oven shelf, insert the roasting pan in the shelf level below to catch the juices.

Leave the joint to stand for at least 15 minutes, so that the meat juices do not run out.

To reduce the build up of smoke in the oven, it is recommended to pour a little water in the roasting pan. To prevent condensation forming, add water several times. The plates can be kept warm in the oven at minimum temperature until serving.



Caution!

Do not line the oven with aluminium foil and do not place a roasting pan or baking tray on the floor, as otherwise the oven enamel will be damaged by the heat build-up.

Cooking times

Cooking times can vary according to the different composition, ingredients and amounts of liquid in the individual dishes.

Note the settings of your first cooking or roasting experiments to gain experience for later preparation of the same dishes.

Based upon your own experiences you will be able to alter the values given in the tables.

Baking and Roasting Table

Conventional Cooking

i Timings do not include pre-heating.
The empty oven should always be pre-heated for 10 minutes.

TYPE OF DISH	Conventional Cooking		Cooking time in minutes	NOTES
	 temp °C	temp °C		
CAKES				
Whisked recipies	2	170	45-60	In cake mould
Shortbread dough	2	170	20-30	In cake mould
Butter-milk cheese cake	1	175	60-80	In cake mould
Apple cake (Apple pie)	1	170	90-120	In cake mould
Strudel	2	180	60-80	In baking tray
Jam- tart	2	190	40-45	In cake mould
Fruit cake	2	170	60-70	In cake mould
Sponge cake	1	170	30-40	In cake mould
Christmas cake	1	150	120-150	In cake mould
Plum cake	1	175	50-60	In bread tin
Small cake	3	170	20-35	In baking tray
Biscuits	2	160	20-30	In baking tray
Meringues	2	135	60-90	In baking tray
Buns	2	200	12-20	In baking tray
Pastry: Choux	2or 3	210	25-35	In braking tray
Plate tarts	2	180	45-70	In cake mould
Rich fruit cake	1	160	110-120	In cake mould
Victoria sandwich	1or2	180	40-55	In cake mould
BREAD AND PIZZA				
White bread	1	195	60-70	
Rye bread	1	190	30-45	In bread tin
Bread rolls	2	200	25-40	In baking tray
Pizza	2	200	20-30	In baking tray
Scones	3	200	10-20	In baking tray
FLANS				
Pasta flan	2	200	40-50	In mould
Vegetable flan	2	200	45-60	In mould
Quiches	1	210	30-40	In mould
Lasagne	2	200	25-35	In mould
Cannelloni	2	200	25-35	In mould
Yorkshire pudding	2	220	20-25	6 pudding mould
MEAT				
Beef	2	190	50-70	On grid
Pork	2	180	100-130	On grid
Veal	2	190	90-120	On grid
English roast beef				
rare	2	210	50-60	On grid
medium	2	210	60-70	On grid
well done	2	210	70-80	On grid
Shoulder of pork	2	180	120-150	With rind
Shin of pork	2	180	100-120	2 pieces
Lamb	2	190	110-130	Leg
Chicken	2	190	70-85	Whole
Turkey	2	180	210-240	Whole
Duck	2	175	120-150	Whole
Goose	2	175	150-200	Whole
Rabbit	2	190	60-80	Cut in pieces
Hare	2	190	150-200	Cut in pieces
Pheasant	2	190	90-120	Whole
Meat loaf	2	180	150	in bread pan
FISH				
Trout/Sea bream	1	190	40-55	3-4 fishes
Tuna fish/Salmon	2	190	35-60	4-6 fillets

If you wish to cook more than one dish at the same time, we suggest that you change the cooking levels of your dishes during the last 5-10 minutes in order to obtain a more uniform colour of your dishes.

(*) If you need to cook more than one dish at the same time, we recommend you to place them on the levels quoted between brackets. Shelf positions are counted from bottom of the oven.

Grilling -

i Timings do not include pre-heating.
The empty oven should always be pre-heated for 10 minutes.

TYPE OF DISH	Quantity		Grilling		Cooking time in minutes	
	Pieces	g.		temp.°C	1st side	2nd side
Fillet steaks	4	800	3	250	12~15	12~14
Beef-steaks	4	600	3	250	10~12	6~8
Sausages	8	/	3	250	12~15	10~12
Pork chops	4	600	3	250	12~16	12~14
Chicken (cut in two)	2	1000	3	250	30~35	25~30
Kebabs	4	/	3	250	10~15	10~12
Chicken (breast)	4	400	3	250	12~15	12~14
Hamburger*	6	600	2	250	20-30	
*Preheat 5'00"						
Fish (fillets)	4	400	3	250	12~14	10~12
Sandwiches	4~6	/	3	250	5~7	/
Toast	4~6	/	3	250	2~4	2~3

i The temperatures quoted are guidelines. The temperatures may have to be adapted to personal requirements.

Cleaning and Maintenance



Before cleaning always allow the cooling fan to cool the oven down before switching off at the electricity supply.

This appliance cannot be cleaned with steam or with a steam cleaning machine.

The oven should be kept clean at all times. A build-up of fats or other foodstuffs could result in a fire, especially in the grill pan.

Important: Before carrying out any cleaning operation, the appliance must be disconnected from the power supply.

External cleaning

Regularly wipe over the control panel, oven door and door seal using a soft cloth well wrung out in warm water to which a little mild washing-up liquid has been added.

To prevent damaging or weakening the door glass panels avoid the use of the following:

- Household detergent and bleaches
- Impregnated pads unsuitable for non-stick saucepans
- Brillo/Ajax pads or steel wool pads
- Chemical oven pads or aerosols
- Rust removers
- Bath/Sink stain removers

Clean the outer and inner door glass using warm soapy water. Should the inner door glass become heavily soiled it is recommended that a cleaning product such as Hob Brite is used. Do not use paint scrapers to remove soilage.

Cleaning materials

Before using any cleaning materials on your oven, check that they are suitable and that their use is recommended by the manufacturer.

Cleaners that contain bleach should NOT be used as they may dull the surface finishes. Harsh abrasives should also be avoided.

Oven Cavity

The enamelled base of the oven cavity is best cleaned whilst the oven is still warm.

Wipe the oven over with a soft cloth soaked in warm soapy water after each use. From time to time it will be necessary to do a more thorough cleaning, using a proprietary oven cleaner.

Cleaning the Oven Door

Before cleaning the oven door, we recommend you to remove it from the oven.

Proceed as follows:

1. open the oven door completely;
2. find the hinges linking the door to the oven (Fig. A);
3. unlock and turn the small levers located on the two hinges (Fig. B);
4. handle the door by its left- and right-hand sides, then slowly turn it towards the oven until it is half-closed (Fig. C);
5. gently pull the oven door off its site (Fig. C);
6. place it on a steady plan;

Clean the oven door glass with warm soapy water and a soft cloth only. Never use harsh abrasives. Once the cleaning is carried out, refit the oven door, following the procedure in reverse.

Stainless steel or aluminium appliances:

We recommend that the oven door is only cleaned using a wet sponge and dried after cleaning with a soft cloth.

Never use steel wool, acids or abrasive products as they can damage the oven surface. Clean the oven control panel following the same precautions.



DO NOT clean the oven door while the glass panels are warm. If this precaution is not observed the glass panel may shatter.

If the door glass panel becomes chipped or has deep scratches, the glass will be weakened and must be replaced to prevent the possibility of the panel shattering. Contact your local Service Centre who will be pleased to advise further.

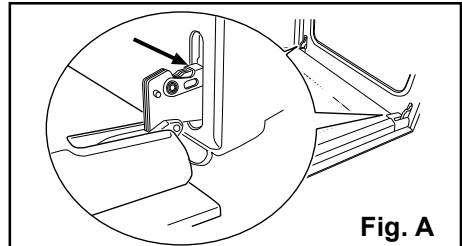

Fig. A

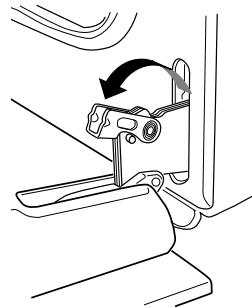

Fig. B

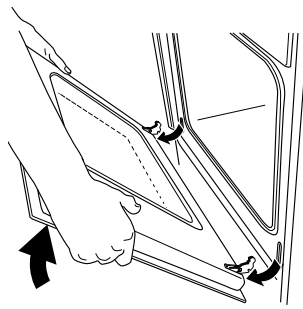

Fig. C

Replacing The Oven Light

Disconnect the appliance

If the oven bulb needs replacing, it must comply with the following specifications:

- Electric power: 15 W/25 W,
- Electric rate: 230 V (50 Hz),
- Resistant to temperatures of 300°C,
- Connection type: E14.

These bulbs are available from your local Service Force Centre.

To replace the faulty bulb:

1. Ensure the oven is isolated from the electrical supply.
2. Push in and turn the glass cover anticlockwise.
3. Remove the faulty bulb and replace with the new one.
4. Refit the glass cover and restore the electrical supply.

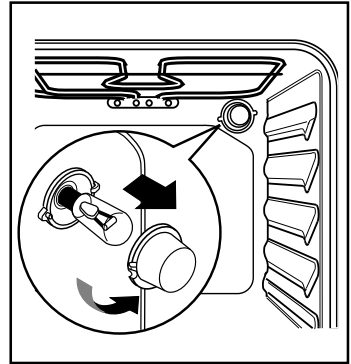

If something is wrong

If the appliance is not working correctly, please check the following before contacting the Electrolux Service Centre:

PROBLEM	SOLUTION
<ul style="list-style-type: none"> ■ The oven is not switching on. 	<ul style="list-style-type: none"> ◆ Check that both a cooking function and temperature have been selected or ◆ Check whether the appliance is correctly connected and the socket switch or the mains supply to the oven is ON.
<ul style="list-style-type: none"> ■ The oven temperature light does not come on. 	<ul style="list-style-type: none"> ◆ Select a temperature with the thermostat control knob or ◆ Select a function with the oven function control knob.
<ul style="list-style-type: none"> ■ The oven light does not come on. 	<ul style="list-style-type: none"> ◆ Select a function with the oven function control knob or ◆ Check the light bulb, and replace it if necessary (see "Cleaning and maintenance")
<ul style="list-style-type: none"> ■ It takes too long to cook the dishes or they cook too quickly. 	<ul style="list-style-type: none"> ◆ The temperature may need adjusting or ◆ Following the advice contained in these instructions, especially the section "Using the oven".
<ul style="list-style-type: none"> ■ Steam and condensation settle on the food and in the oven cavity. 	<ul style="list-style-type: none"> ◆ When the cooking process is completed, do not leave the dishes standing in the oven for longer than 15-20 minutes.

Technical Data

Heating element ratings

Bottom oven element	1000 W
Top heating element	800 W
Full oven (Top + Bottom)	1800 W
Grill	1650 W
Full grill	2450 W
Oven light	25 W
Cooling Fan	25 W
Total rating	2500 W
Operating voltage (50 Hz)	230 V

Dimensions of the recess

Height	under top	mm 593
	in column	mm 580
Width		mm 560
Depth		mm 550

Oven

Height	mm 335
Width	mm 405
Depth	mm 410
Oven capacity	56 l

Electrical Connection

The oven is designed to be connected to 230 V (50 Hz) electricity supply.

The oven has an easily accessible terminal block which is marked as follows:

- Letter L - Live terminal
- Letter N - Neutral terminal
-  or E - Earth terminal



THIS OVEN MUST BE EARTHED

The cable used to connect the oven to the electrical supply must comply to the specifications given below.

It is necessary that you install a double pole switch between the oven and the electricity supply (mains), with a minimum gap of 3mm between the switch contacts and of a type suitable for the required load in compliance with the current rules.

The switch must not break the yellow and green earth cable at any point.

the yellow and green earth cable should be 2-3 cm longer than the other cables.

Important

After installation and connecting, the cable must be placed so that it cannot at any point reach a temperature of more than 60°C above the ambient temperature.

Before the oven is connected, check that the main fuse and the domestic installation can support the load and that the power supply is properly earthed.

The manufacturer declines any responsibility should these safety measures not be carried out.

Connection via	Min. size Cable/flex	Cable/flex type	Fuse
13 A socket outlet	2.5 mm ²	3 core butyl insulated	13 A min.
13 A spur box			
Oven Control Circuit	2.5 mm ²	PVC/PVC twin and earth	15 A min. 20 A max.

For Europe use only

Min. size Cable/flex	Cable / flex type	Fuse
2.5 mm ²	H07 RN-F, H05 RN-F, H05 RR-F, H05 VV-F, H05 V2V2-F (T90), H05 BB-F	15 A

Instructions for Building In

Please ensure that when the oven is installed it is easily accessible for the engineer in the event of a breakdown.

Building In

The surround or cabinet into which the oven will be built must comply with these specifications:

- the dimensions must be as shown in the relevant diagrams;
- the materials must withstand a temperature increase of at least 60 °C above ambient;
- proper arrangements must be made of a continuous supply of air to the oven to prevent the oven overheating.

Dimensions of the oven and recess required are given in the relevant diagrams.

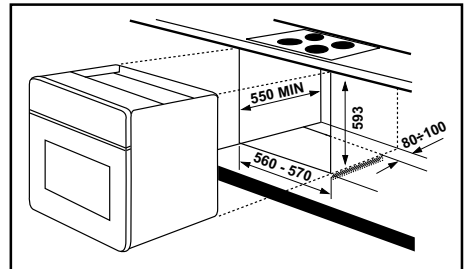
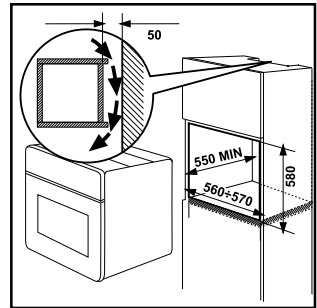
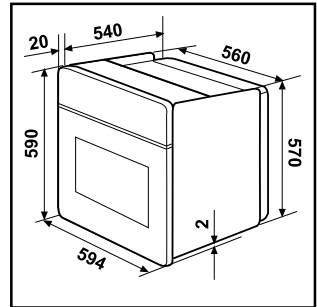

Securing the Appliance to the Cabinet

1. Open the oven door.
2. Fasten the oven to the cabinet placing the four distance holders (letter A) which fit exactly into the holes in the frame and then fit the four wood screws (letter B) provided.

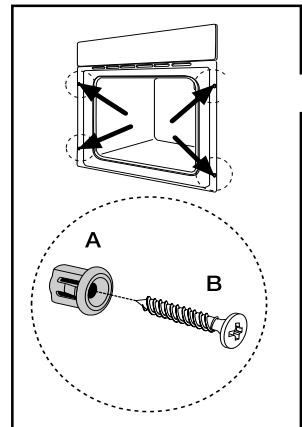

Guarantee/Customer Service

Standard guarantee conditions

We, Zanussi - Electrolux, undertake that if within 12 months of the date of the purchase this Zanussi - Electrolux appliance or any part thereof is proved to be defective by reason only of faulty workmanship or materials, we will, at our option repair or replace the same FREE OF CHARGE for labour, materials or carriage on condition that:

- The appliance has been correctly installed and used only on the electricity supply stated on the rating plate.
- The appliance has been used for normal domestic purposes only, and in accordance with the manufacturer's instructions.
- The appliance has not been serviced, maintained, repaired, taken apart or tampered with by any person not authorised by us.
- Electrolux Service Force Centre must undertake all service work under this guarantee
- Any appliance or defective part replaced shall become the Company's property.
- This guarantee is in addition to your statutory and other legal rights.

Exclusions

- Damage or calls resulting from transportation, improper use or neglect, the replacement of any light bulbs or removable parts of glass or plastic.
- Costs incurred for calls to put right an appliance which is improperly installed or calls to appliances outside the United Kingdom.
- Appliances found to be in use within a commercial environment, plus those which are subject to rental agreements.
- Products of Electrolux manufacturer that are not marketed by Electrolux

Service and Spare Parts

In the event of your appliance requiring service, or if you wish to purchase spare parts, please contact your local Service Force Centre by telephoning **0870 5 929 929**

Your telephone call will be automatically routed to the Service Force Centre covering your postcode area.

For the address of your local Service Force Centre and further information about Service Force, please visit the website at

www.serviceforce.co.uk

Before calling out an engineer, please ensure you have read the details under the heading "Something not working" When you contact the Service Force Centre you will need to give the following details:

1. Your name, address and postcode.
2. Your telephone number.
3. Clear concise details of the fault.
4. The model and Serial number of the appliance (found on the rating plate).
5. The purchase date.

Please note a valid purchase receipt or guarantee documentation is required for in guarantee service calls.

Customer Care

For general enquiries concerning your Electrolux appliance, or for further information on Electrolux products please contact our Customer Care Department by letter or telephone at the address below or visit our website at

www.electrolux.co.uk

Customer Care Department

Electrolux Major Appliances

Addington Way

Luton

Bedfordshire, LU4 9QQ

Tel: 08705 727 727 (*)

(*) Calls may be recorded for training purposes

European Guarantee

This appliance is guaranteed by Electrolux in each of the countries listed at the back of this user manual, for the period specified in the appliance guarantee or otherwise by law. If you move from one of these countries to another of the countries listed below the appliance guarantee will move with you subject to the following qualifications:

- The appliance guarantee starts from the date you first purchased the appliance which will be evidenced by production of a valid purchase document issued by the seller of the appliance.
- The appliance guarantee is for the same period and to the same extent for labour and parts as exists in your new country of residence for this particular model or range of appliances.
- The appliance guarantee is personal to the original purchaser of the appliance and cannot be transferred to another user.
- The appliance is installed and used in accordance with instructions issued by Electrolux and is only used within the home, i.e. is not used for commercial purposes.
- The appliance is installed in accordance with all relevant regulations in force within your new country of residence.

The provisions of this European Guarantee do not affect any of the rights granted to you by law.

www.electrolux.com

		
Albania	+35 5 4 261 450	Rr. Pjeter Bogdani Nr. 7 Tirane
Belgique/België/Belgien	+32 2 363 04 44	Bergensesteenweg 719, 1502 Lembeek
Česká republika	+420 2 61 12 61 12	Budějovická 3, Praha 4, 140 21
Danmark	+45 70 11 74 00	Sjællandsgade 2, 7000 Fredericia
Deutschland	+49 180 32 26 622	Muggenhofer Str. 135, 90429 Nürnberg
Eesti	+37 2 66 50 030	Pärnu mnt. 153, 11624 Tallinn
España	+34 902 11 63 88	Carretera M-300, Km. 29,900 Alcalá de Henares Madrid
France	www.electrolux.fr	
Great Britain	+44 8705 929 929	Addington Way, Luton, Bedfordshire LU4 9QQ
Hellas	+30 23 10 56 19 70	4, Limnou Str., 54627 Thessaloniki
Hrvatska	+385 1 63 23 338	Slavonska avenija 3, 10000 Zagreb
Ireland	+353 1 40 90 753	Long Mile Road Dublin 12
Italia	+39 (0) 434 558500	C.so Lino Zanussi, 26 - 33080 Porcia (PN)
Latvija	+37 17 84 59 34	Kr. Barona iela 130/2, LV-1012, Riga
Lietuva	+370 5 2780609	Ozo 10A, LT 08200 Vilnius
Luxembourg	+352 42 431 301	Rue de Bitbourg, 7, L-1273 Hamm
Magyarország	+36 1 252 1773	H-1142 Budapest XIV, Erzsébet királyné útja 87
Nederland	+31 17 24 68 300	Vennootsweg 1, 2404 CG - Alphen aan den Rijn
Norge	+47 81 5 30 222	Risløkkvn. 2, 0508 Oslo
Österreich	+43 18 66 400	Herziggasse 9, 1230 Wien
Polska	+48 22 43 47 300	ul. Kolejowa 5/7, Warszawa
Portugal	+35 12 14 40 39 39	Quinta da Fonte - Edificio Gonçalves Zarco - Q 35 -2774-518 Paço de Arcos
Romania	+40 21 451 20 30	Str. Garii Progresului 2, S4, 040671 RO
Schweiz - Suisse - Svizzera	+41 62 88 99 111	Industriestrasse 10, CH-5506 Mägenwil
Slovenija	+38 61 24 25 731	Gerbičeva ulica 98, 1000 Ljubljana
Slovensko	+421 2 43 33 43 22	Electrolux Slovakia s.r.o., Electrolux Domáce spotrebiče SK, Seberínho 1, 821 03 Bratislava
Suomi	www.electrolux.fi	
Sverige	+46 (0)771 76 76 76	Electrolux Service, S:t Göransgatan 143, S-105 45 Stockholm
Türkiye	+90 21 22 93 10 25	Tarlabası caddesi no : 35 Taksim İstanbul
Россия	+7 495 937 7837	129090 Москва, Олимпийский проспект, 16, БЦ "Олимпик"

	ES	DA	DE	EL	EN	FR	IT	NL	PT	SV	FI	
1	Fabricante	Mærke	Hersteller	Προμηθευτής	Manufacturer	Fabricant	Costruttore	Fabrikant	Fabricante	Leverantör	Tavarantoimittaja	ZANUSSI
2	Modelo	Model	Modell	Μοντέλο	Model	Modèle	Modello	Model	Modelo	Modell	Malli	ZOB 150
3	Clase de eficiencia energética	Relativt energigifbrug	Energieeffizienzklasse	Τάξη ενεργειακής απόδοσης	Energy efficiency class	Classement selon son efficacité énergétique	Classe di efficienza energetica	Energie-efficiëntieklasse	Classe de eficiência energética	Energieeffektivitetsklass	Energialohokussuokka	A
4	- Calentamiento convencional - Convección forzada	- Traditionel opvarmning - Varmluft	- Konventionelle Beheizung - Um/Heißluft	- Συμβατική θέρμανση αέρα	- Conventional - Forced air convection	- Classique - Convection forcée	- Convezione naturale - Convezione forzata	- Conventioneel - Geforceerde luchtconvector	- Conveccion - Conveccion forçada de ar	- Konventionell värmning - Värmning med varmluft	- Ylä-alalämpö - Kiertolämpö	←
5	Consumo de energía Función de calentamiento	Energiforbrug Opvarmningsfunktion	Energieverbrauch Beheizung	Κτανάλωση ενέργειας Αποστογή θέρμανσης	Energy consumption Heating function	Consommation d'énergie Fonction chauffage	Consumo di energia Funzione di riscaldamento	Energieverbruik Verhittingsfunctie	Consumo de energia Função de aquecimento	Energiförbrukning Värmningsfunktion	Energiankulutus Kuumentusta pä-	
6	- Calentamiento convencional - Convección forzada	- Traditionel opvarmning - Varmluft	- Konventionelle Beheizung - Um/Heißluft	- Συμβατική θέρμανση αέρα	- Conventional - Forced air convection	- Classique - Convection forcée	- Convezione naturale - Convezione forzata	- Conventioneel - Geforceerde luchtconvector	- Conveccion - Conveccion forçada de ar	- Konventionell värmning - Värmning med varmluft	- Ylä-alalämpö - Kiertolämpö	0.79 kWh
7	- Vapor	- Dampf	- Dampf	- Ατμός	- Steam	- Vapeur	- Vapore	- Stoom	- Vapor	- Ånga	- Höyry	
8	Volumen neto (litros)	Netto-volumen (liter)	Netto-volumen (Liter)	Ωφέλιμος όγκος (λίτρο)	Usable volume (litres)	Volumé utile (litres)	Volumé utile (litri)	Netto volume (liter)	Netto volume (Litros)	Användbar volym (liter)	Käyttötilavuus (litraa)	56
9	•• Pequeño ••• Medio •••• Grande	Type: - Lille - Mellemstort - Stort	Typ: - Klein - Mittel - Groß	Τύπος: - Μικρός - Μεσoίος - Μεγάλος	Size: - Small - Medium - Large	Type: - Faible volume - Volume moyen - Grand volume	Type: - Piccolo - Medio - Grande	Type: - Klein - Middelgroot - Groot	Type: - Klein - medio - grande	Type: - peqüeno - medelstor - Suuri	Koko: - Pieni - Keskipikokoinen - Suuri	←
10	•• Tiempo de cocción con carga normal	Tilberedningstid ved standardbelasting	Kochzeit bei Standardbeladung	Χρόνος για τυρίμα τυποποιημένου φούρτου	Time to cook standard load	Temps de cuisson en charge normale	Tempo necessario per cottura carico normale	Bereidings-tijd bij standaardbelasting	Tempo de cozedura da carga-padrão	Tillagningstid för en standardbelastning	Pastotaika vakioormalla	
11	- Calentamiento convencional - Convección forzada	- Traditionel opvarmning - Varmluft	- Konventionelle Beheizung - Um/Heißluft	- Συμβατική θέρμανση αέρα	- Conventional - Forced air convection	- Classique - Convection forcée	- Convezione naturale - Convezione forzata	- Conventioneel - Geforceerde luchtconvector	- Conveccion - Conveccion forçada de ar	- Konventionell värmning - Värmning med varmluft	- Ylä-alalämpö - Kiertolämpö	43 min.
12	Superficie de la placa de cocción de mayor tamaño	Arealaf den største bageplade	Größe des größten Backblechs	Η μεγαλύτερη επιφάνεια ψησίματος αποκρυσταλλωμένη	The area of the largest baking sheet	Aire de la surface de la plus grande plaque pour pâtisserie	Superficie del piano di cottura più grande	Oppervlakte van de grootste bakplaat	Área da superfície da maior placa de pasteleria	Ytan för den största bakplaten	Suurimman leivipinnan ala	1130 cm ²
13	Ruido dB (A) re 1 pW	Lydeffektniveau dB (A) (Støj)	Geräusch dB (A) re 1 pW	Ήχημα [dB (A) ανά 1 pW]	Noise dB (A) re 1 pW	Bruit dB (A) re 1 pW	Rumore dB (A) re 1 pW	Geluidsniveau dB (A) re 1 pW	Nível de ruído dB (A) re 1 pW	Bullemliv dB (A)	Ääni dB (A) re 1 pW	
<p> ● Más eficiente / Bassi consumi / Efficient / Niedriger Verbrauch / Mais efficace / Lää kulutus / More efficient / Vähän kuluttava / Economie ●● Menos eficiente / Højt forbrug / Hoher Verbrauch / Nöyryä kuluttava / Less efficient / Paljon kuluttava / Peu economie ●●● 12 l ◀ Volumen neto / Netto volume / Volume utilisable / Käyttötilavuus / < 35 l ●●●● 35 l ◀ Volumen neto / Netto volume / Volume utilisable / Käyttötilavuus / < 65 l ●●●●● 65 l ◀ Volumen neto / Netto volume / Volume utilisable / Käyttötilavuus </p>												
2002/40/EC												



www.electrolux.com

www.zanussi-electrolux.co.uk

Free Manuals Download Website

<http://myh66.com>

<http://usermanuals.us>

<http://www.somanuals.com>

<http://www.4manuals.cc>

<http://www.manual-lib.com>

<http://www.404manual.com>

<http://www.luxmanual.com>

<http://aubethermostatmanual.com>

Golf course search by state

<http://golfingnear.com>

Email search by domain

<http://emailbydomain.com>

Auto manuals search

<http://auto.somanuals.com>

TV manuals search

<http://tv.somanuals.com>