

RANGE COMPOSITION

N 900: a range of over 150 models for the professional caterer designed to guarantee the highest level of performance, reliability, energy saving, safety standards and ergonomic operation. These concepts are reflected in the total modularity of the range that ensures innumerable configurations, either free-standing, bridged or cantilever. N900 demonstrates how advanced technology can satisfy the needs of the professional caterer.

The models detailed on this sheet are 2 electric automatic pasta cookers with automatically tilting baskets, with direct heating and with one or two baskets, ideal for the cooking in water of pasta rice, minestrone, boiled meat etc.



Model 200395

N 900

ELECTRIC AUTOMATIC PASTA COOKERS **ZANUSSI** PROFESSIONAL

FUNCTIONAL AND CONSTRUCTION FEATURES

- ◆ Load bearing frame in stainless steel.
- ◆ Front and side panels in stainless steel with satin finish.
- ◆ Cooking basket and all other parts in contact with water are made from 316 AISI stainless steel.
- ◆ Heating via armoured stainless steel elements.
- ◆ Automatic water filling and automatic water topping up.
- ◆ Automatic refilling of the evaporated water.
- ◆ Digital timer guaranteeing precise settings of cooking parameter.
- ◆ Wells with rounded corners in 316 AISI stainless steel with mirror finish, highly resistant to salt corrosion.
- ◆ Elevating baskets which are automatically and independently tilted at the end of the cooking cycle by an electromechanic linear activator fed at low tension (24 V)
- ◆ Electrovalve with probe to prevent heating in the case of no water. Automatic ignition when water reaches minimum level.
- ◆ Electronic control end limit basket.
- ◆ Large drainage taps with insulated handle positioned on the front of the appliance
- ◆ Feet in stainless steel, adjustable up to a height of 200 mm.
- ◆ Insulated lid and handle in stainless steel

fitted on hinges with counter-balancing springs.

- ◆ Independent, simple and functional control panel provided with transparent plexiglass protection.
- ◆ Well fitted with overflow pipe to eliminate foam.
- ◆ Timer for programming cooking times.

- ◆ High productivity and quality due to high thermal efficiency and automatically controlled cooking times.
- ◆ The special design of the control knob system guarantees against water infiltration.
- ◆ All models provided with service duct to facilitate installation.
- ◆ IPX5 water protection.

TECHNICAL DATA		
CHARACTERISTICS	MODELS	
	NCPE800H 200395	NCPE1210H 200392
Power supply	Electric	Electric
External dimensions - mm		
width	800	1600
depth	900	900
height	850	850
height adjustment	50	50
N° of wells	1	2
Usable well dimensions - mm		
width	530	625
depth	570	640
height	550	410
Basket load capacity - kg	15	15
Power - kW		
installed-electric	15	30
Control panel - V	24	24
Net Weight - lb	364	683
Supply voltage	400 V, 3N, 50	400 V, 3N, 50

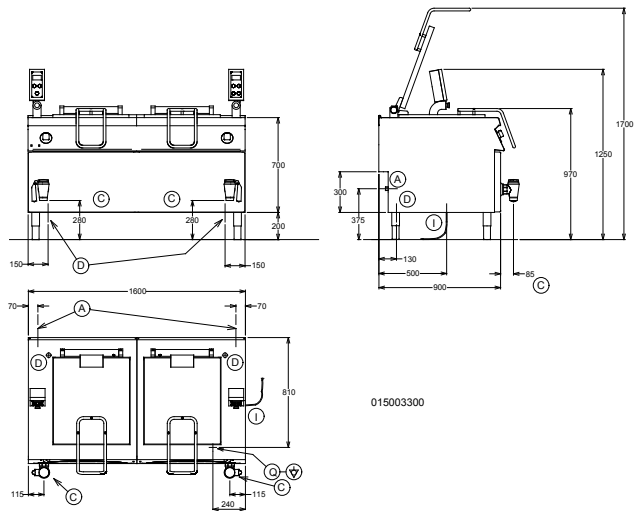
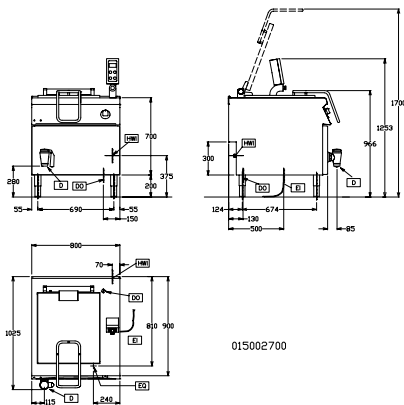

LEGEND

	NCPE800H 200395	NCPE1210H 200392
CW/I/B - Cold water inlet	3/4"	3/4"
D/C - Water drain	2"	2"
DO/D - Overflow drain pipe	●	●
EI/I - Electrical connection	400 V, 3N, 50	400 V, 3N, 50



OPTIONAL ACCESSORIES

ACCESSORIES	MODELS	
	NCPE800H 200395	NCPE1210H 200392
2 SIDE COVERING PANELS H=700 D=900	206134	206134
2 SIDE KICKING STRIPS	206180	206180
FRONTAL HANDRAIL 1600 MM		206192
FRONTAL HANDRAIL 800 MM	206167	
FRONTAL KICKING STRIP 1600 MM		206179
FRONTAL KICKING STRIP 800 MM	206176	
KIT HACCP EKIS	922166	922166
PASTA COOKER TROLLEY FOR 2-GN 1/1 CONT.	921011	921011
PASTA COOKER TROLLEY WITH TILTING TANK	921012	921012
SIDE HANDRAIL-RIGHT/LEFT HAND	206165	206165



www.zanussiprofessional.com

Free Manuals Download Website

<http://myh66.com>

<http://usermanuals.us>

<http://www.somanuals.com>

<http://www.4manuals.cc>

<http://www.manual-lib.com>

<http://www.404manual.com>

<http://www.luxmanual.com>

<http://aubethermostatmanual.com>

Golf course search by state

<http://golfingnear.com>

Email search by domain

<http://emailbydomain.com>

Auto manuals search

<http://auto.somanuals.com>

TV manuals search

<http://tv.somanuals.com>