



DA402

Stripe® Series Direct Thermal Printer

User's Guide

Rev. 2
Customer order # 52005L
Manufacturer part # 52005LB

Proprietary Statement

This manual contains proprietary information of Zebra Technologies Corporation. It is intended solely for the information and use of parties operating and maintaining the equipment described herein. Such proprietary information may not be used, reproduced, or disclosed to any other parties for any other purpose without the expressed written permission of Zebra Technologies Corporation.

Product Improvements

Continuous improvement of products is a policy of Zebra Technologies Corporation. All specifications and signs are subject to change without notice.

FCC Compliance Statement

NOTE: This equipment has been tested and found to comply with the limits for a Class B digital device, pursuant to Part 15 of the FCC Rules. These limits are designed to provide reasonable protection against harmful interference in a residential installation. This equipment generates, uses, and can radiate radio frequency energy and, if not installed and used in accordance with the instructions, may cause harmful interference to radio communications. However, there is no guarantee that the interference will not occur in a particular installation. If this equipment does cause harmful interference to radio or television reception, which can be determined by turning the equipment off and on, the user is encouraged to try to correct the interference by one or more of the following measures:

- Reorient or relocate the receiving antenna.
- Increase the separation between the equipment and the receiver.
- Connect the equipment into an outlet on a circuit different than that to which the receiver is connected.
- Consult the dealer or an experienced Radio/TV technician for help.

NOTE: This unit was tested with shielded cables on the peripheral devices. Shielded cables must be used with the unit to insure compliance.

"The user is cautioned that any changes or modifications not expressly approved by Zebra Technologies Corporation could void the user's authority to operate the equipment."

Canadian DOC Compliance Statement

This digital apparatus does not exceed the Class A limits for radio noise emissions from digital apparatus as set out in the radio interference regulations of the Canadian Department of Communications.

Liability Disclaimer

Zebra Technologies Corporation takes steps to assure that its published Engineering specifications and Manuals are correct; however, errors do occur. Zebra Technologies Corporation reserves the right to correct any such errors and disclaims liability resulting therefrom.

No Liability for Consequential Damage

In no event shall Zebra Technologies Corporation or anyone else involved in the creation, production, or delivery of the accompanying product (including hardware and software) be liable for any damages whatsoever (including, without limitation, damages for loss of business profits, business interruption, loss of business information, or other pecuniary loss) arising out of the use of or the results of use of or inability to use such product, even if Zebra Technologies Corporation has been advised of the possibility of such damages. Because some states do not allow the exclusion or limitation of liability for consequential or incidental damages, the above limitation may not apply to you.

Copyrights

This copyrighted manual and the label printer described herein are owned by Zebra Technologies Corporation. All rights are reserved. Unauthorized reproduction of this manual or the software in the label printer may result in imprisonment of up to one year and fines of up to \$10,000 (17 U.S.C.506). Copyright violators may be subject to civil liability.

All products and brand names are trademarks of their respective companies. All rights reserved.
© 1999 Zebra Technologies Corporation

DECLARATION OF CONFORMITY

I have determined that the Zebra printers identified as the

Stripe[®] Series
DA402 and T402

manufactured by:

Zebra Technologies Corporation
333 Corporate Woods Parkway
Vernon Hills, Illinois 60061-3109 U.S.A.

have been shown to comply with the applicable technical standards of the FCC

for Home, Office, Commercial, and Industrial use

if no unauthorized change is made in the equipment,
and if the equipment is properly maintained and operated.

Clive Kueser

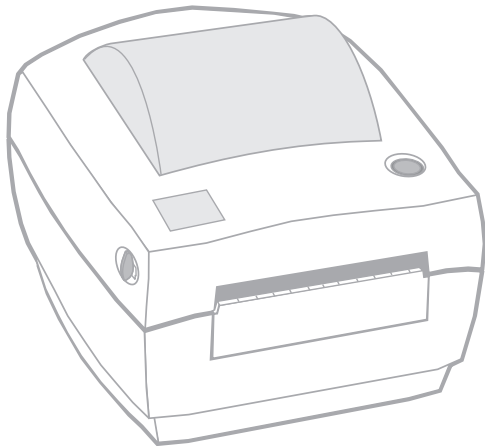

Contents

Introduction

Hello!	1
What's in the Box	1
Unpacking and Inspection	2
Reporting Damage	2
DC Power Supply	3
Printer Overview (illustration)	4

Getting Ready to Print

Loading the Media.	5
Tear-Off Mode	5
Peel-Off Mode	9
Cutter Mode.	14
Fanfold Media	17
Auto Calibration	18
Operator Controls	19
Power Switch	19
Feed Button	19
Status LED	19
Printing a Test Label	20
Hooking Up the Printer and Computer.	20
Serial (RS-232) Interface Requirements	20
Parallel Interface Requirements	21
Serial and Parallel Cabling Requirements	21
Communicating with the Printer	22
Via the Serial Port	22
Via the Parallel Port.	22
Using ZPL II	23
Adjusting the Print Width	23
Adjusting the Print Darkness.	23
Adjusting the Print Speed	23

Troubleshooting

What the Status LED is Telling You	25
Print Quality Problems	26
Manual Calibration	28
Troubleshooting Tests	29
Printing a Configuration Label	29
Recalibration	29
Resetting the Factory Default Values	30
Communications Diagnostics	30
Feed Button Modes	31

Maintenance

Cleaning	33
Lubrication	33
Parts List	35
Replacing the Printhead	36
Removing the Printhead	36
Installing the Printhead	38

Specifications

Printing	41
Label/Tag	42
Font/Bar Code	43
Physical/Environmental/Electrical	43
Agency Approvals	44
Options	44
Serial (RS-232) Connector Technical Information	45
Interconnecting to DTE Devices	45
Interconnecting to DCE Devices	45
Parallel Interface Technical Information	48

Index

Introduction

Hello!

Thank you for choosing the Zebra® DA402™ Printer. This rugged little printer is certain to become a productive and efficient addition to your workplace!

- This user's guide provides the information you will need to operate and maintain the printer.
- To create and print label formats, take a look at the *ZPL II Programming Guide*. If one was not ordered with your printer, simply call your distributor or visit our web site at www.zebra.com.



NOTE: Many printer settings may also be controlled by your printer's driver or label preparation software. Refer to the driver or software documentation for more information.

What's in the Box

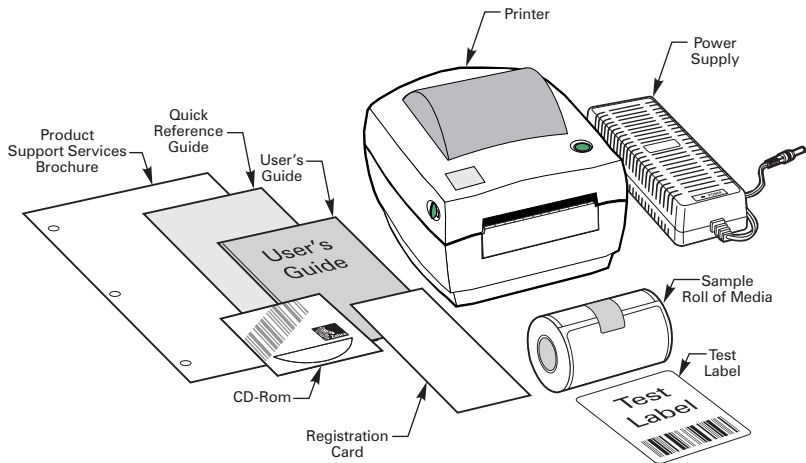

Unpacking and Inspection

Inspect the printer for possible shipping damage:

- Check all exterior surfaces for damage.
- Raise the top cover (refer to “[Loading the Media](#)” on page 5) and inspect the media compartment for damage.

In case shipping is required, save the carton and all packing material.

Reporting Damage

If you discover shipping damage:

- Immediately notify and file a damage report with the shipping company.
Zebra Technologies Corporation is not responsible for any damage incurred during shipment of the printer and will not cover the repair of this damage under its warranty policy.
- Keep the carton and all packing material for inspection.
- Notify your authorized reseller.



WARNING: NEVER OPERATE THE PRINTER AND POWER SUPPLY IN AN AREA WHERE THEY CAN GET WET. SERIOUS PERSONAL INJURY COULD RESULT!

DC Power Supply

Refer to Figure 1.

1. The DC power supply has a barrel connector on one end that must be inserted into the power supply receptacle on the back of the printer.
2. Insert the separate AC power cord into the power supply.
3. Plug the other end of the cord into an appropriate AC electrical outlet.

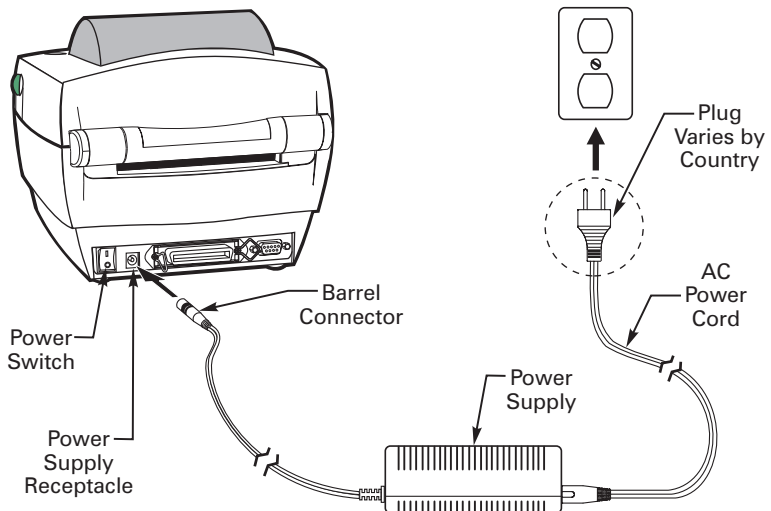

Figure 1

Printer Overview

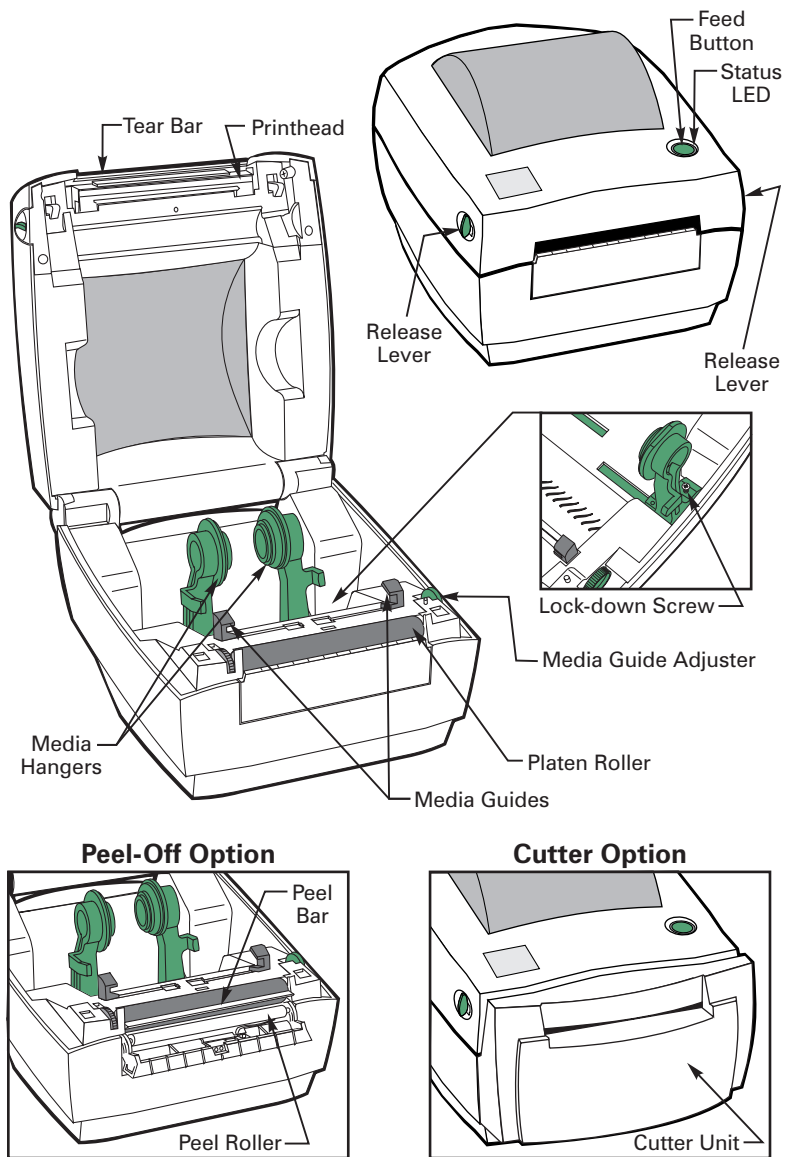

Figure 2

Getting Ready to Print

Loading the Media

You can operate this printer in three different modes: tear-off, peel-off, or with a cutter.

- Tear-off mode allows you to tear off each label (or a strip of labels) after it is printed.
- In peel-off mode, the backing material is peeled away from the label as it is printed. After this label is removed, the next one is printed.
- In cutter mode, the printer automatically cuts the label after it is printed.

Tear-Off Mode

1. Unlatch the top cover by pulling the two green release levers toward you (refer to Figure 3). Then, lift the top cover to expose the media compartment.

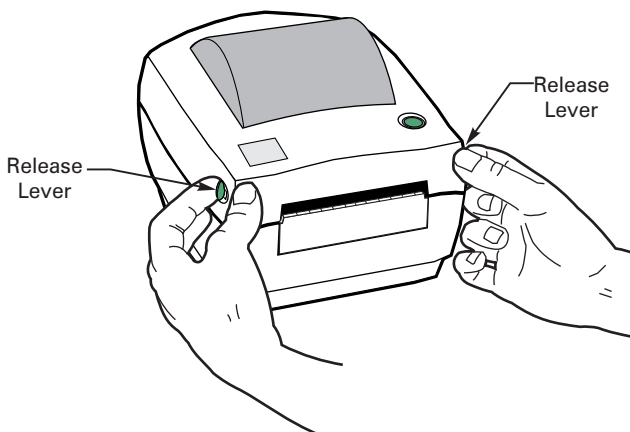

Figure 3

2. Separate and hold open the media hangers (refer to Figure 4).
3. Place the media roll onto the media hangers, ensuring that it is tightly wound (refer to Figure 5).



NOTE: Refer to [Figure 6](#). If you are using labels, make sure the media unwinds from the top of the roll. Tags unwind from the bottom of the roll.

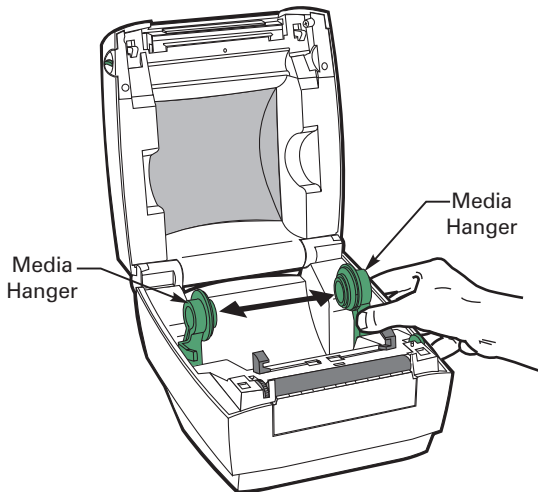

Figure 4

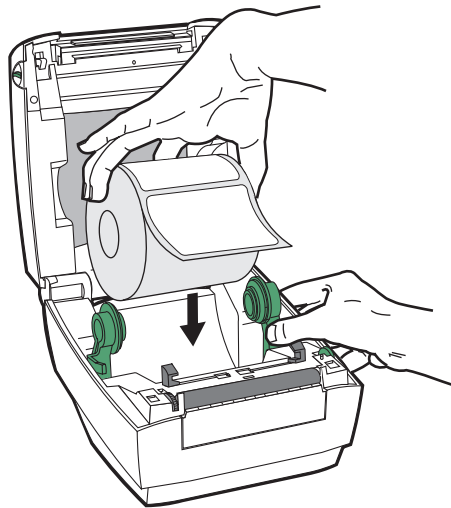

Figure 5

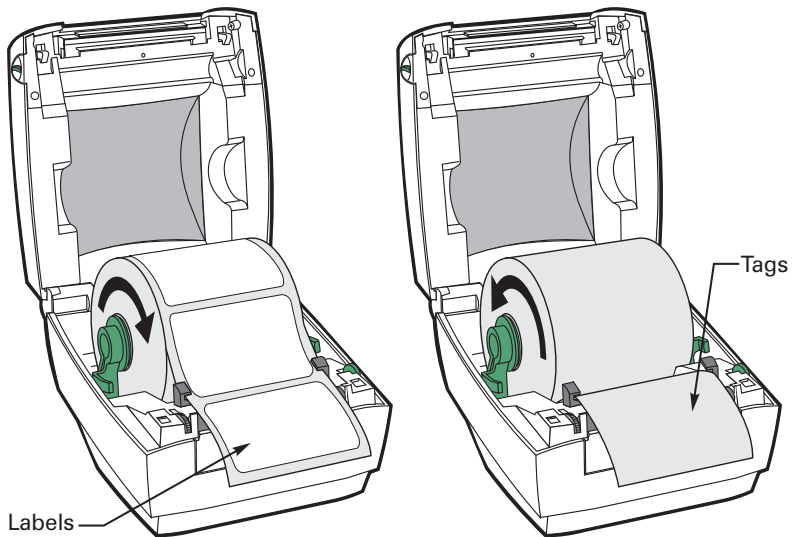

Figure 6

4. Refer to Figure 7. Thread the media through the media guides.



NOTE: If the media guides must be changed to accommodate the width of the media, turn the green media guide adjuster (refer to Figure 7). The media guides should just touch, but not restrict, the edges of the media.

5. Close the top cover and turn on the printer *or* press the feed button if the printer is already on (see “Auto Calibration” on page 18 for more information).

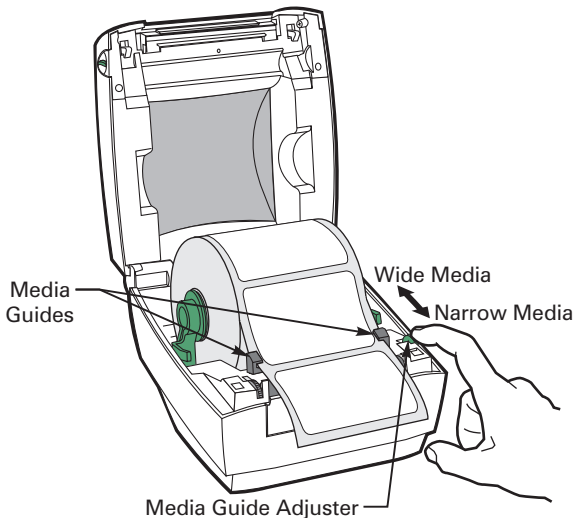

Figure 7

Peel-Off Mode (optional)

1. Unlatch the top cover by pulling the two green release levers toward you (refer to Figure 8). Then, lift the top cover to expose the media compartment.

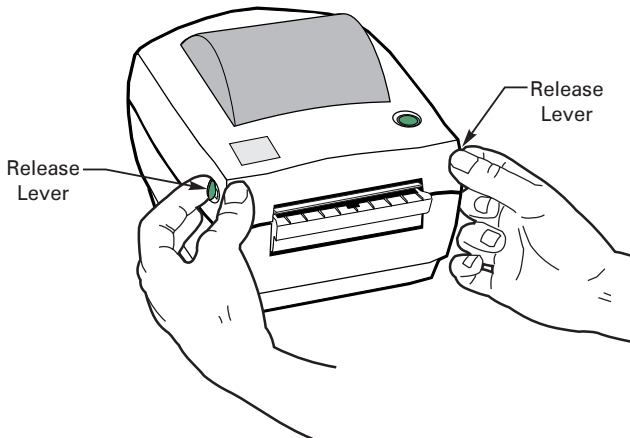

Figure 8

2. Separate and hold open the media hangers (refer to Figure 9).
3. Place the media roll onto the media hangers, making sure it is tightly wound (refer to Figure 10).
4. Open the peel-off unit by pulling down on its textured top surface (refer to Figure 11).
5. Activate the peel-off unit by moving the peel-off switch to the left (refer to Figure 11 inset).



NOTE: When not operating the printer in peel-off mode, **always** deactivate the peel-off unit by moving the peel-off switch to the right.

6. Remove approximately 6” (152 mm) of labels from the label backing.

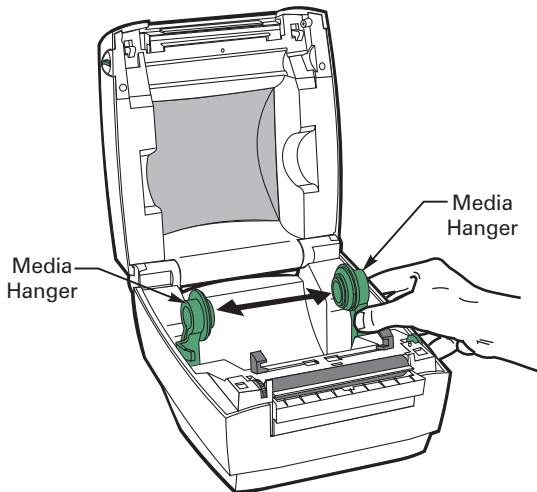

Figure 9

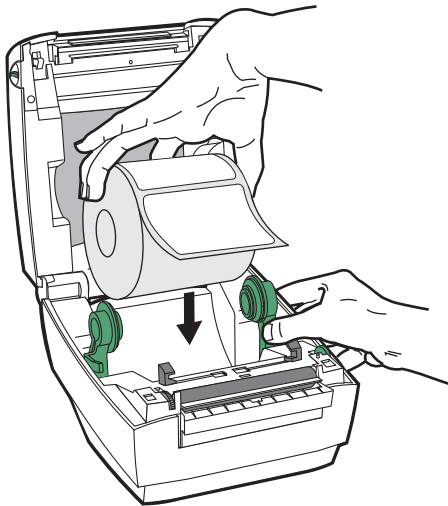

Figure 10

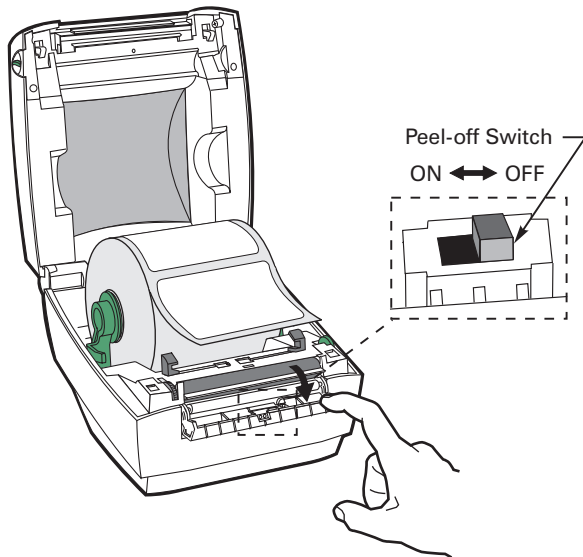

Figure 11

7. Refer to Figure 12. Thread the label backing through the media guides and over the peel bar.



NOTE: If the media guides must be changed to accommodate the width of the media, turn the green media guide adjuster (refer to Figure 12). The media guides should just touch, but not restrict, the edges of the media.

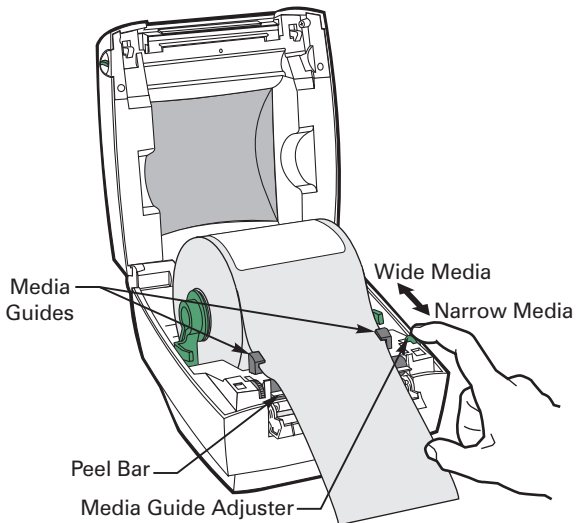

Figure 12

8. Thread the label backing between the black platen roller and white peel roller until it comes out of the slot beneath the peel-off unit (refer to Figure 13).
9. Close the peel-off unit by pushing in on its smooth side surface.
10. To remove any slack, rewind media onto the roll.
11. Close the top cover and turn on the printer *or* press the feed button if the printer is already on (see “[Auto Calibration](#)” on page 18 for more information).

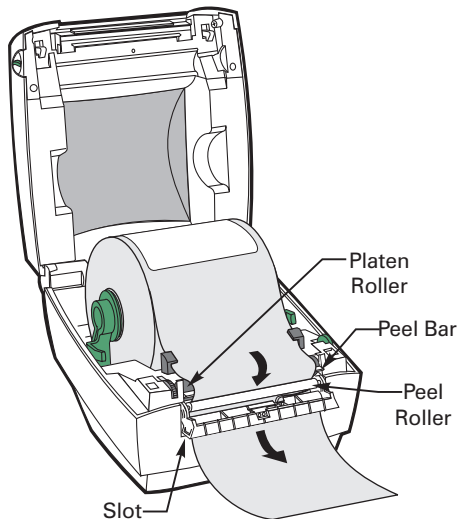

Figure 13

Cutter Mode (optional)



NOTE: The cutter is designed to cut through paper labels or the backing between labels, not the adhesive backing of the label. Adhesive build-up on the cutter blade may cause the cutter to jam.

1. Unlatch the top cover by pulling the two green release levers toward you (refer to Figure 14). Then, lift the top cover to expose the media compartment.
2. Separate and hold open the media hangers (refer to [Figure 15](#)).
3. Place the media roll onto the media hangers, ensuring that it is tightly wound (refer to [Figure 16](#)).

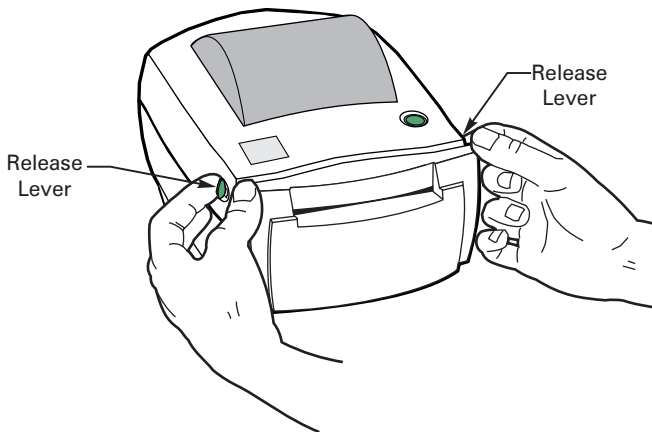

Figure 14

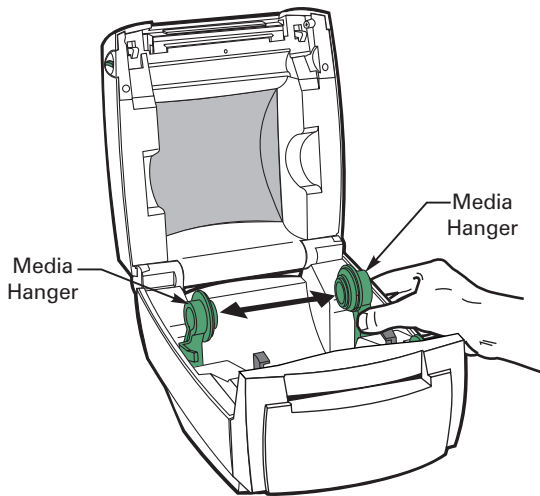

Figure 15

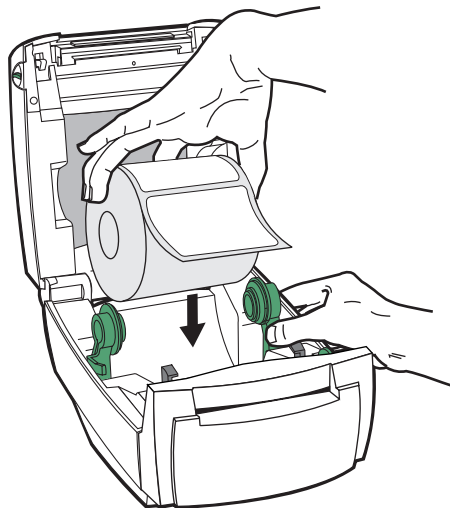

Figure 16

4. Refer to Figure 17. Thread the media through the media guides.



NOTE: If the media guides must be changed to accommodate the width of the media, turn the green media guide adjuster (refer to Figure 17). The media guides should just touch, but not restrict, the edges of the media.

5. Refer to Figure 17. Thread the media through the cutter unit.
6. Close the top cover and turn on the printer *or* press the feed button if the printer is already on (see “[Auto Calibration](#)” on page 18 for more information).

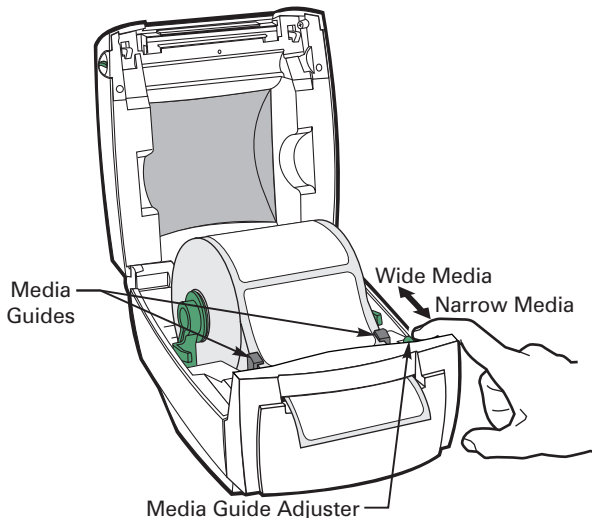

Figure 17

Fanfold Media

Fanfold media loads from the outside of the printer. Refer to Figure 18.

1. Thread the media through the access slot in the back of the printer.
2. Separate and hold open the media hangers.
3. Lock the media hangers in position by tightening the screw located on the right media hanger.



CAUTION: Do not overtighten the screw! Overtightening could pierce the case and damage the printer's electronics!

4. Thread the media through the media guides.



NOTE: If the media guides must be changed to accommodate the width of the media, turn the green media guide adjuster. Media guides should just touch, but not restrict, the edges of the media.

5. Close the top cover and turn on the printer *or* press the feed button if the printer is already on (see “[Auto Calibration](#)” on page 18 for more information).

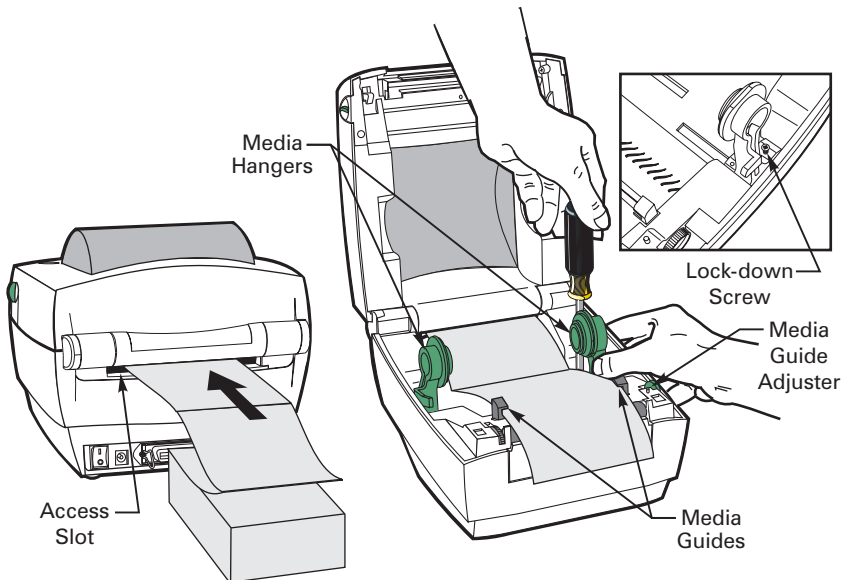

Figure 18

Auto Calibration



NOTE: *If you are using pre-printed labels, pre-printed label backing, or continuous media, see “[Manual Calibration](#)” on page 28.*

An auto calibration is performed when the printer is turned on (if media is loaded) or after a media error is cleared. When it is auto calibrating, the printer sets the sensor levels for, and determines the length of, the label you are using.

If the status LED flashes red, refer to “[Manual Calibration](#)” on page 28.

Operator Controls

Refer to Figure 19.

Power Switch

- Press to turn on and turn off the printer.



CAUTION: The power should be turned off before connecting or disconnecting the communications and power cables.

Feed Button

- Forces the printer to feed one blank label.
- Takes the printer out of a “pause” condition. (The printer is put into “pause” by either a ZPL II command or an error condition.) See “[What the Status LED is Telling You](#)” on page 25.
- Used for printer setup and status (see “[Feed Button Modes](#)” on page 31).

Status LED

- Functions as a printer operational indicator (see “[What the Status LED is Telling You](#)” on page 25).

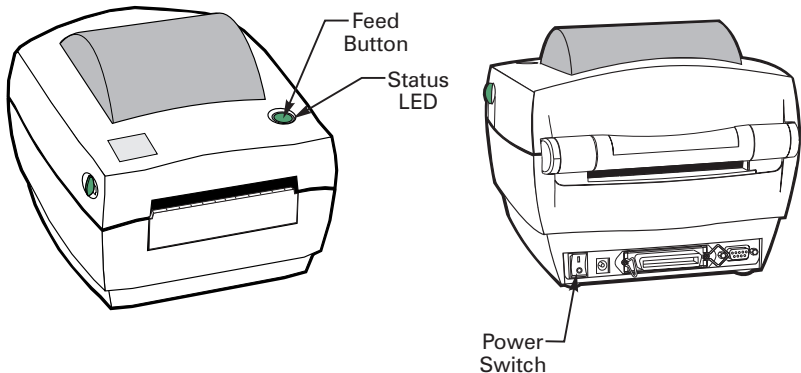

Figure 19

Printing a Test Label

Before you connect the printer to your computer, make sure that the printer is in proper working order. You can do this by printing a configuration label:

1. Make sure the media is properly loaded and the top cover of the printer is closed. Then, turn the printer power on if you have not already done so.
2. When the status LED is solid green, press and hold the feed button until the status LED flashes once.
3. Release the feed button. A configuration label will print.

If you cannot get this label to print, refer to [Troubleshooting](#).

Hooking Up the Printer and Computer



CAUTION: *The power supply barrel connector must be inserted into the power supply receptacle on the back of the printer before connecting or disconnecting the communications cables. (If necessary, refer to [Figure 1](#).)*

This printer comes with both a nine-pin Electronics Industries Association (EIA) RS-232 serial data interface and an IEEE 1284-compliant bidirectional parallel data interface. In either case, you must supply the required interface cable for your application.



CAUTION: *This printer complies with FCC “Rules and Regulations,” Part 15, for Class B Equipment, using fully shielded six-foot data cables. Use of longer cables or unshielded cables may increase radiated emissions above the Class B limits.*

Serial (RS-232) Interface Requirements

The required cable must have a nine-pin “D” type (DB-9P) male connector on one end, which is plugged into the mating (DB-9S) serial port located on the back of the printer (refer to Figure 20). The other end of this signal interface cable connects to a serial port at the host computer. Depending on the specific interface requirements, this will most likely be a null modem cable.

For [technical and pinout information](#), refer to page 45.

Parallel Interface Requirements

The required cable (IEEE 1284-compliant is recommended) must have a standard 36-pin parallel connector on one end, which is plugged into the parallel port located on the back of the printer (refer to Figure 20). The other end of the parallel interface cable connects to the printer connector at the host computer.

For [pinout information](#), refer to page 48.

Serial and Parallel Cabling Requirements

Data cables must be of fully shielded construction and fitted with metal or metalized connector shells. Shielded cables and connectors are required to prevent radiation and reception of electrical noise.

To minimize electrical noise pickup in the cable:

- Keep data cables as short as possible (6' [1.83 m] recommended).
- Do not tightly bundle the data cables with power cords.
- Do not tie the data cables to power wire conduits.

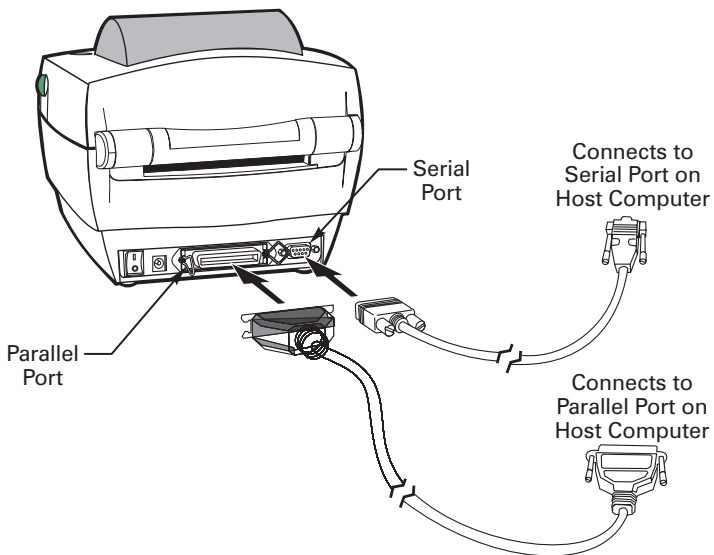

Figure 20

Communicating with the Printer

Via the Serial Port

Serial communications between the printer and the host computer can be set by either autobaud synchronization or the ^SC command.

Autobaud

Autobaud synchronization allows the printer to automatically match the communication parameters of the host computer. To autobaud:

1. Press and hold the feed button until the green status LED flashes once, twice, and then three times.
2. While the status LED flashes, send a ZPL II format to the printer.
3. When the printer and host are synchronized, the LED changes to solid green. (No labels will print during autobaud synchronization.)

^SC Command

Use the Set Communications (^SC) command to change the communications settings on the printer.

1. With the host computer set at the **same** communications settings as the printer, send the ^SC command to change the printer to the desired settings.
2. Change the host computer settings to match the new printer settings.

Refer to the *ZPL II Programming Guide* for more information about this command.

Setting the Communications Parameters

To reset the communications parameters on the printer to the factory defaults (9600 baud, 8 bit word length, no parity, 1 stop bit, and XON/XOFF), do the following:

1. Press and hold the feed button until the green status LED flashes once, twice, and then three times.
2. While the status LED rapidly flashes yellow and green, press the feed button.

Via the Parallel Port

Typically, no setup is required once the cable is plugged in. If you should encounter any problems, consult the user's guide that came with your computer.

Using ZPL II

For detailed information about creating labels using ZPL II, refer to the *ZPL II Programming Guide* or visit our web site at www.zebra.com.

Adjusting the Print Width

Print width must be calibrated when:

- You are using the printer for the first time.
- There is a change in the width of the media.

Print width may be set by way of the five-flash sequence in “[Feed Button Modes](#)” (see page 31) or refer to the Print Width (^PW) command (consult your *ZPL II Programming Guide*).

Adjusting the Print Darkness

The relative darkness setting is controlled by either the six-flash sequence in “[Feed Button Modes](#)” (see page 31) or the Set Darkness (~SD) ZPL II command (follow the instructions in the *ZPL II Programming Guide*).

Adjusting the Print Speed

Print quality is affected by print speed *and* the media you are using. Only by experimenting will you find the optimal mix for your application.

If you find that the print speed needs to be adjusted, refer to the Print Rate (^PR) command in the *ZPL II Programming Guide*.

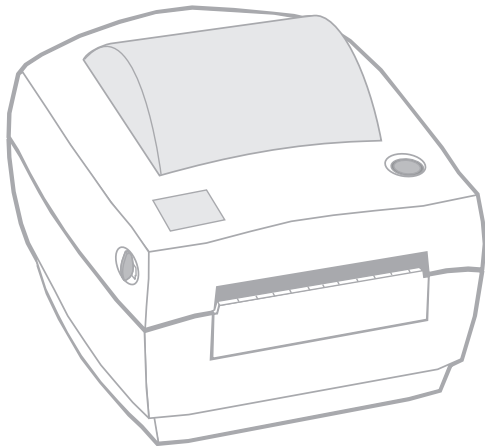

Troubleshooting

What the Status LED is Telling You

Status LED Condition and Color	Printer Status	For a Resolution, Refer to:
Off	Off	1
Solid Green	On	2
Flashing Yellow	Stopped	3
Flashing Green	Normal Operation	4
Flashing Red	Stopped	5
Double Flashing Green	Paused	6
Solid Yellow	Various	7
Alternately Flashing Green and Red	Needs Service	8

RESOLUTIONS:

1. The printer is not receiving power.

- Have you turned on the printer power?
- Check power connections from the wall outlet to the power supply, and from the power supply to the printer.

2. The printer is on and in an idle state.

3. The printer has failed its power on self test (POST).

- If this error occurs right after you turn on the printer, contact an authorized reseller for assistance.

There is a shortage of memory.

- If this error occurs after you have been printing, turn the printer power off and on. Then, resume printing.

4. The printer is receiving data.

- As soon as all of the data has been received, the status LED will turn green; then, the printer will automatically resume operation.

5. The media is out.

- Load a roll of media, following the instructions in [“Loading the Media”](#) on page 5. Then, press the feed button to resume printing.

The printhead is open.

- Close the top cover. Then, press the feed button to resume printing.

The cutter is jammed.

- Turn off the printer and remove any jammed labels from the cutter unit. Then, turn on the printer to resume printing.

6. The printer is paused.

- Press the feed button to resume printing.

7. The printhead is under temperature.

- Continue printing while the printhead reaches the correct operating temperature.

The printhead is over temperature.

- Printing will stop until the printhead cools to an acceptable printing temperature. When it does, the printer will automatically resume operation.

8. FLASH memory is not programmed.

- Return the printer to an authorized reseller.

Print Quality Problems

No print on the label.

- Make sure the correct media (direct thermal) is loaded. Try this: Quickly rub your nail or a blunt object over the label surface. If it does not produce dark marks, the wrong media (thermal transfer) is loaded.
- Is the media loaded correctly? Follow the instructions in [“Loading the Media”](#) on page 5.

The printed image does not look right.

- The printhead is dirty. [Clean the printhead](#) according to the instructions on page 33.
- The printhead is under temperature.

- Adjust the print darkness and/or print speed. Refer to the six-flash sequence in [“Feed Button Modes”](#) on page 31, or the ^PR and ~SD commands in the *ZPL II Programming Guide*.
- The media being used is incompatible with the printer. Be sure to use the recommended media for your application, and *always* use Zebra-approved labels and tags.

There are long tracks of missing print (blank vertical lines) on several labels.

- The printhead is dirty. [Clean the printhead](#) according to the instructions on page 33.
- The printhead elements are damaged. Replace the printhead (see [“Replacing the Printhead”](#) on page 36).

The printing does not start at the top of the label, or misprinting of one to three labels.

- The media may not be threaded under the media guides. Refer to [“Loading the Media”](#) on page 5.
- The printer needs to be calibrated. Refer to [“Auto Calibration”](#) on page 18.
- The correct media sensor may not be activated. Manual calibration selects the media sensing method for the labels being used (refer to the ^MN command in the *ZPL II Programming Guide*).
- Verify that the Label Top (^LT) command is correctly set for your application (consult the *ZPL II Programming Guide*).

A label format was sent to, but not recognized by, the printer.

- Is the printer in pause mode? If so, press the feed button.
- If the status LED is on or flashing, refer to [“What the Status LED is Telling You”](#) on page 25.
- Make sure the data cable is correctly installed.
- A communications problem has occurred. First, make sure that the correct communications port on the computer is selected. Next, verify that the same handshaking is in use by both the printer and the computer. Then, ensure that the baud rates of the printer and the computer match. Refer to [“Communicating with the Printer”](#) on page 22.

Manual Calibration

Manual calibration is recommended whenever you are using pre-printed labels (or label backing) or if the printer will not correctly auto calibrate.

1. Turn on the printer power.
2. Remove approximately 4" (102 mm) of labels from a section of backing material. Load the media so that only the backing material is threaded through the printer and under the printhead.
3. Press and hold the feed button until the green status LED flashes once, then twice. Release the feed button.
4. The printer will set the media sensor for the label backing being used. After it is done making this adjustment, the roll will automatically feed until a label is positioned at the printhead.
5. A profile of the media sensor settings (similar to the example in Figure 21) will print. Upon completion, the printer will save the new settings in memory and the printer is ready for normal operation.
6. Press the feed button. One entire blank label will feed. If this does not happen, try defaulting (refer to the four-flash sequence in "[Feed Button Modes](#)" on page 31) and recalibrating the printer.



NOTE: *Performing a manual calibration disables the auto calibration function. To return to auto calibration, default the printer (see the four-flash sequence in "[Feed Button Modes](#)" on page 31).*

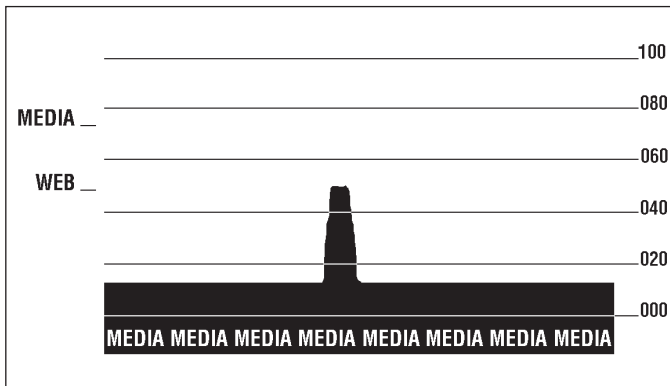

Figure 21

Troubleshooting Tests

Printing a Configuration Label

To print out a listing of the printer's current configuration (an example is shown in Figure 22), refer to the one-flash sequence in “[Feed Button Modes](#)” on page 31.

Recalibration

Recalibrate the printer if it starts to display unusual symptoms, such as skipping labels. See “[Auto Calibration](#)” on page 18.

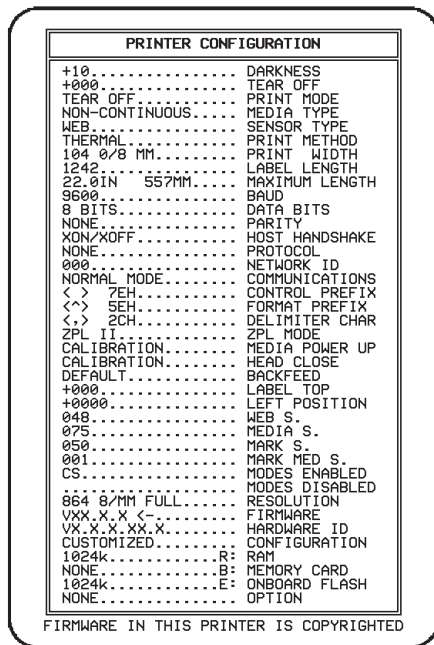

Figure 22

Resetting the Factory Default Values

Sometimes, resetting the printer to the factory defaults solves some of the problems. Follow the four-flash sequence instructions in “[Feed Button Modes](#)” on page 31.

Communications Diagnostics

If there is a problem transferring data between the computer and printer, try putting the printer in the communications diagnostics mode. The printer will print the ASCII characters and their respective hexadecimal values (a sample is shown in Figure 23) for any data received from the host computer. To find out how, refer to the power off mode procedure in “[Feed Button Modes](#)” on page 31.

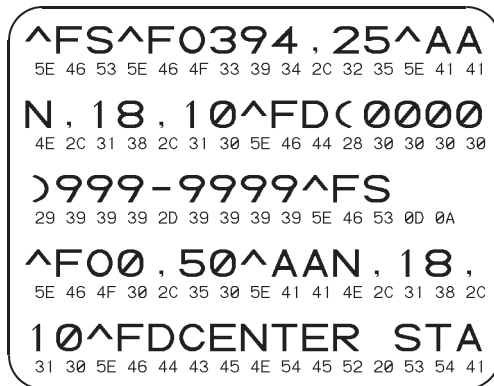
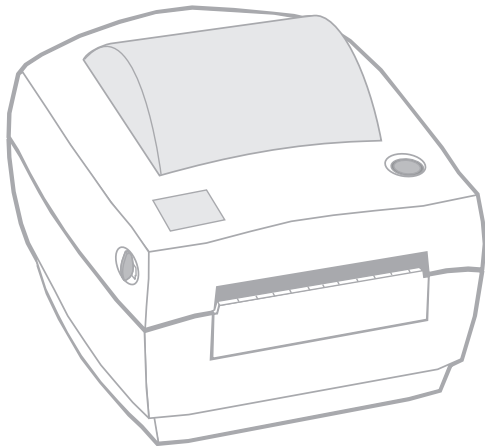

Figure 23

Feed Button Modes

Power Off Mode (Communications Diagnostics Mode)	
<p>With the printer power off, press and hold the feed button while you turn on the power. The printer prints out a listing of its current configuration (see Figure 22). After printing the label, the printer will automatically enter a diagnostic mode in which the printer prints out a literal representation (see Figure 23) of all data subsequently received. To exit the diagnostic mode and resume printing, turn off and then turn on the printer.</p>	
Power On Modes	
<p>With the printer power on and top cover closed, press and hold the feed button for several seconds. The green status LED will flash a number of times in sequence. The explanation at the right (Action) shows what happens when you release the key after the specific number of flashes.</p>	
Flash Sequence	Action
*	A configuration label prints.
* **	The media sensor calibrates and a media sensor profile prints (see "Manual Calibration" on page 28).
* ** ***	<p>To reset the communication parameters: Press and release the feed button while the LED rapidly flashes yellow and green. The serial communication parameters reset to 9600 baud, 8 bits per character, no parity, 1 stop bit, and XON/XOFF.</p> <p>For autobaud synchronization: Send a ZPL II format to the printer while the LED rapidly flashes yellow and green. When the printer and host are synchronized, the LED changes to solid green. NOTE: <i>No labels will print during autobaud synchronization.</i></p>
* ** *** ****	Resets the factory defaults, auto calibrates, and saves settings into memory.
* ** *** **** *****	The print width calibrates. While the status LED alternately flashes green and yellow, a series of stacking rectangles print on the label. When the rectangle prints to the outer edges of the label, press and release the feed button. The label width and current communication parameters will be saved into memory.
* ** *** **** ***** *****	The print darkness calibrates. A series of nine samples print, starting with the lightest and ending with the darkest image. When the desired print darkness is achieved, press and release the feed button. The print darkness will be saved into memory.
<p>If the feed button remains pressed after a 7-flash sequence, the printer will ignore the button when it is released.</p>	



Maintenance

Cleaning



CAUTION: Use only the cleaning agents indicated. Zebra Technologies Corporation will not be responsible for damage caused by any other cleaning materials used on this printer.

If necessary, refer to [Figure 2](#) for part locations.

Area	Method	Interval
Printhead	After allowing the printhead to cool for approximately one minute, use 70% isopropyl alcohol on a cotton swab to clean the print elements from end to end (the print elements are located in the thin gray line on the printhead). NOTE: You do not have to turn off the printer to do this. If print quality has not improved after performing this procedure, try cleaning the printhead with Save-a-Printhead cleaning film. This specially coated material removes contamination buildup without damaging the printhead. Call your authorized reseller for more information.	After every five rolls of media
Platen roller	Manually rotate the platen roller. Clean it thoroughly with 70% isopropyl alcohol and a cotton swab or lint-free cloth.	
Peel bar	Clean it thoroughly with 70% isopropyl alcohol and a cotton swab.	As needed
Tear bar	Clean it thoroughly with 70% isopropyl alcohol and a cotton swab.	As needed
Cutter	Turn off the printer power. Use tweezers to remove the media.	As needed
Exterior	Water-dampened cloth	As needed
Interior	Brush/air blow	As needed

Lubrication



CAUTION! No lubricating agents of any kind should be used on this printer! Some commercially available lubricants, if used, will damage the finish and the mechanical parts inside the printer.

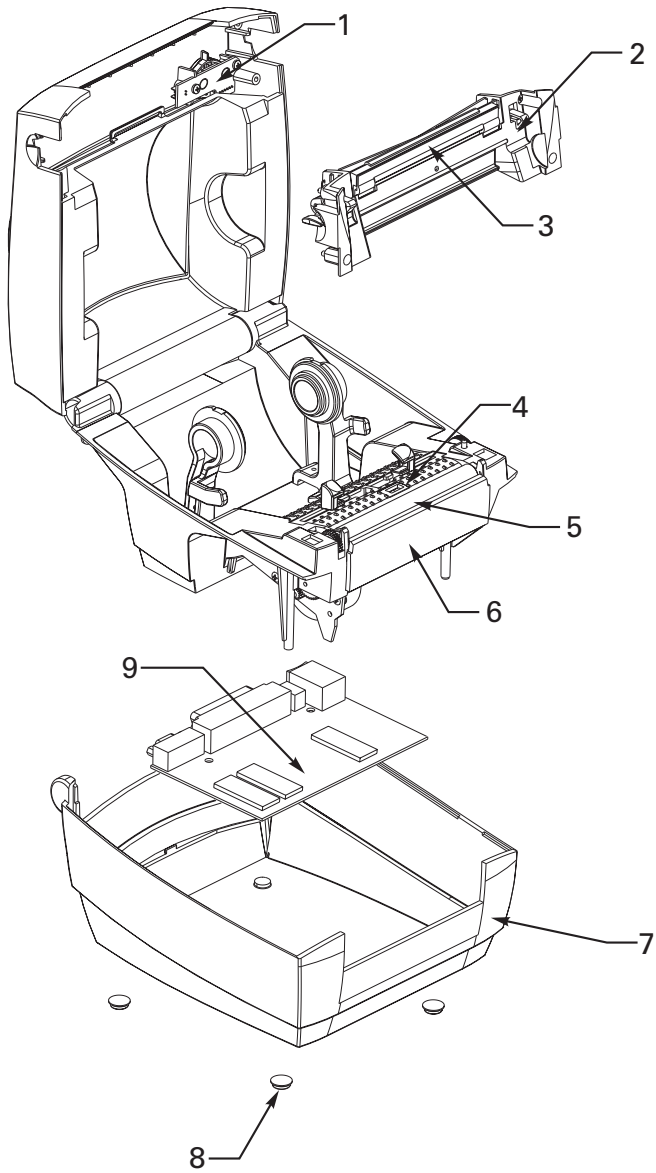

Figure 24

Parts List

Refer to [Figure 24](#).

Item Number	Description	Part Number
1	Feed Switch Assembly (set of 3)	105910-004
2	Printhead and Latch Assembly	105910-003
3	Printhead Assembly	105910-010
4	Media Sensor PCB Assembly (set of 3)	105910-011
5	Platen Roller Kit, Standard (set of 3)	105910-001
	Platen Roller Kit, Linerless	105910-002
6	Front Bezel, Standard (set of 10)	105910-005
	Front Bezel, Peel-Off (set of 5)	105910-012
	Peel-Off Sensor PCB Assembly (set of 3)	105910-013
7	Base Housing (set of 3)	105910-006
8	Rubber Foot Kit (set of 24)	105910-007
9	Main Logic Board Kit, Maintenance	52050M
Not shown:	Stepper Motor, (set of two)	105910-009
	Power Supply Assembly (90-264 VAC, 47-63 Hz)	105903-040
	Power Cord, 110V (set of 5)	105950-014
	Power Cord, 230V European (set of 5)	105950-015
	Power Cord, 230V UK (set of 5)	105950-030
	Power Cord, 230V Australian (set of 5)	105950-029
	Cutter	105910-028
	4M FLASH Memory Option Assembly	52051
	8M FLASH Memory Option Assembly	52052
	4M FLASH Memory w/Real Time Clock Option Assembly	52053
	8M FLASH Memory w/Real Time Clock Option Assembly	52054
	User's Guide	52005L
	Quick Reference Guide	52006L

Replacing the Printhead

Removing the Printhead

1. Turn printer power off and unplug the printer.
2. Refer to Figure 25. Remove the four screws that secure the printhead and latch assembly to the top cover.
3. Refer to Figure 26. Slide the tension bar all the way to the right in its mounting bracket (1). Then, while gently pressing on the opposite mounting bracket (2), lift and remove the tension bar (3).
4. Refer to Figure 27. Remove both printhead wire harness connectors from their receptacles.
5. Refer to Figure 27. Remove the two screws and washers that secure the printhead to the printhead bracket. Then, lift the lip on the front of the printhead bracket to remove the printhead.

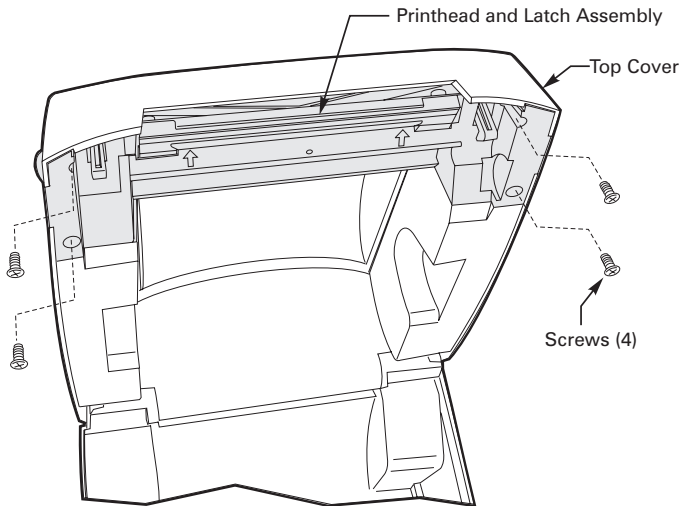

Figure 25

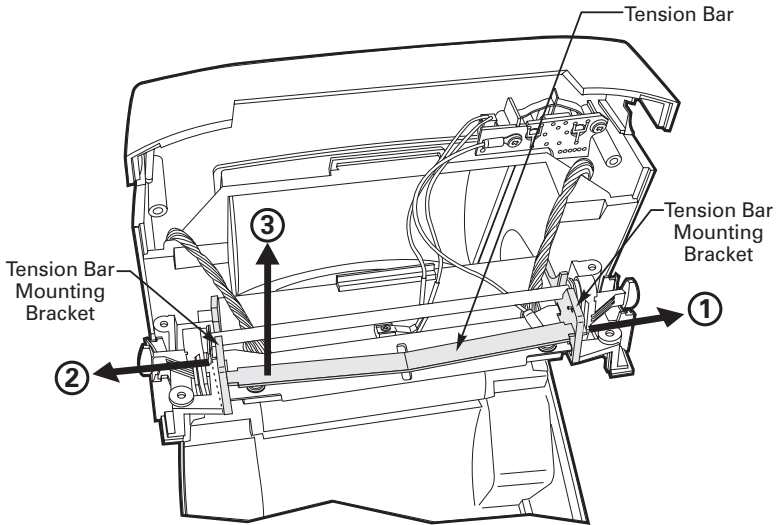

Figure 26

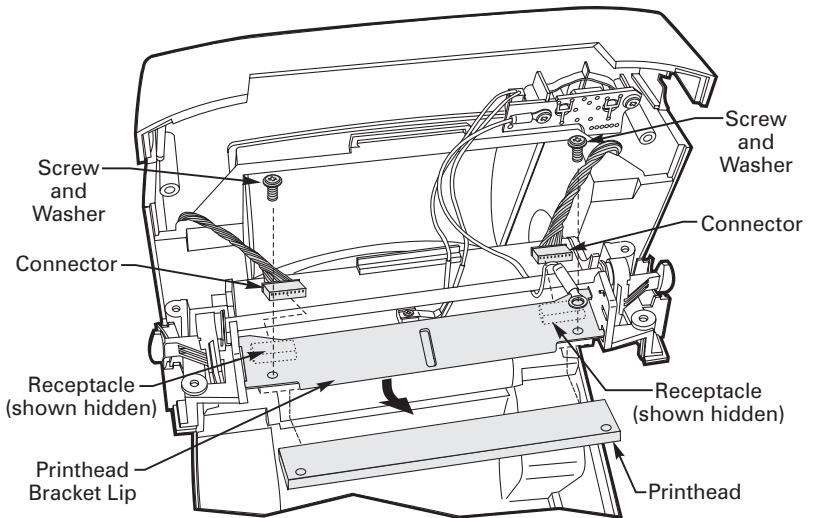

Figure 27

Installing the Printhead

1. Ensure that the printer is turned off and unplugged.
2. Refer to Figure 28. Route the two printhead wire harness connectors as shown. Then, insert the connectors into their receptacles.
3. Insert the printhead into the printhead bracket.
4. Refer to Figure 29. Reinstall the two screws and washers that secure the printhead to the printhead bracket.



NOTE: The green grounding cable, which attaches to the feed switch assembly PC board, must also be secured by one of the screws.

5. Refer to Figure 30. Insert one end of the tension bar into its mounting bracket (1). Then, gently push down on the opposite end of the tension bar until it locks into place (2).



NOTE: Make sure the “V” of the tension bar fits into the notch in the printhead bracket.

6. Ensure that all cables are properly dressed between the printhead and latch assembly *and* the top cover.
7. Reinstall the four screws that secure the printhead and latch assembly to the top cover. Then, plug in the printer and turn on the power.

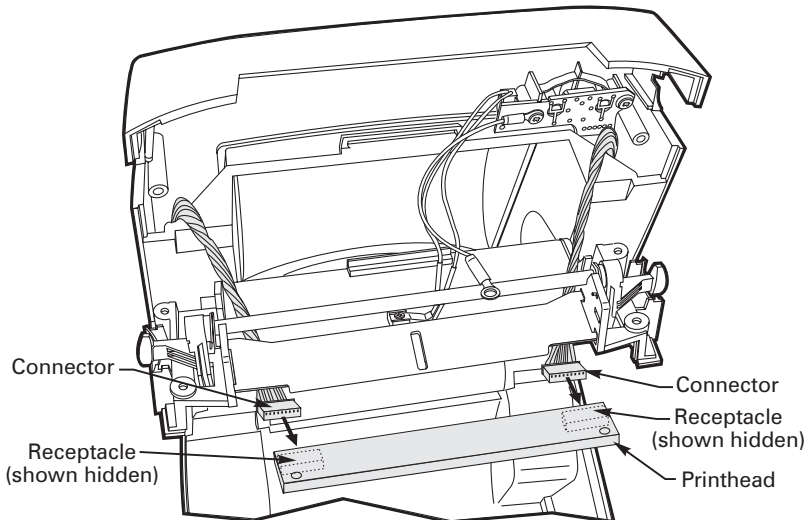

Figure 28

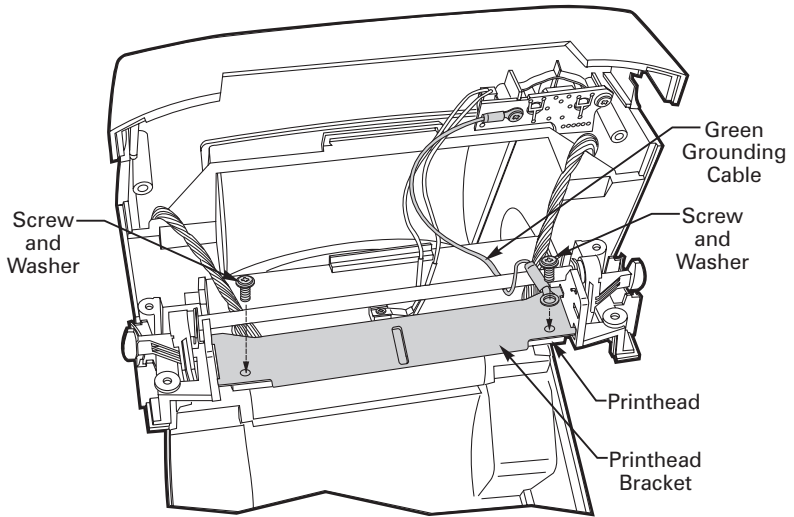

Figure 29

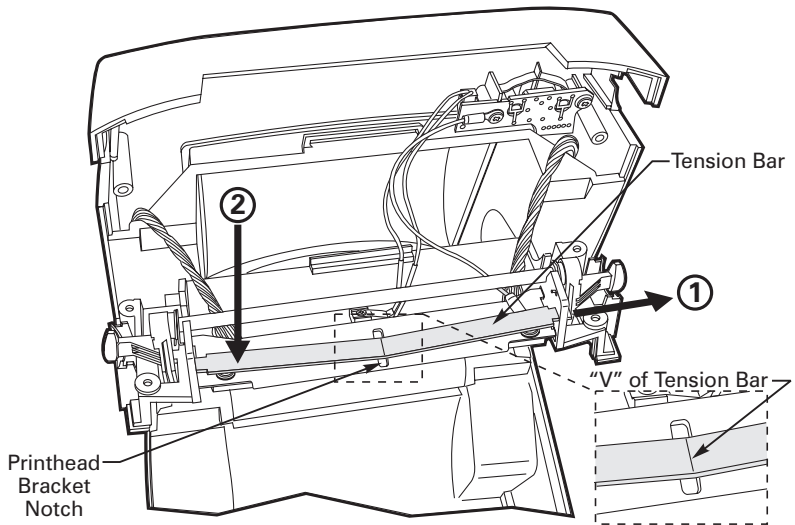
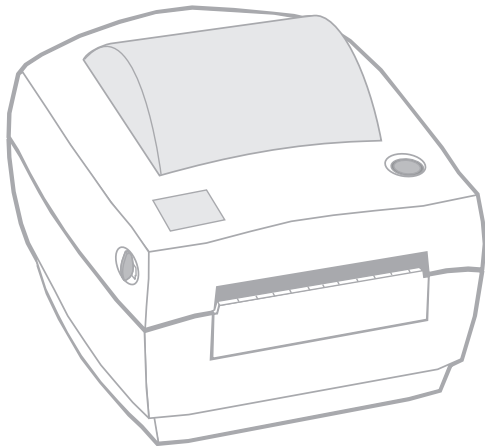

Figure 30



Specifications



NOTE: Printer specifications are subject to change without notice.

Printing Specifications

Print Density	203 dots/inch (8 dots/mm)
Print Speed	1.5" (38 mm), 2" (51 mm), and 2.5" (64 mm) per second
Print Width	1" to 4.09" (25.4 mm to 104 mm) 1" to 2.25" (25.4 mm to 57 mm) for tag stock
Print Length	.005" to 22" (.125 mm to 559 mm) with standard memory
Registration Tolerance	Horizontal: +/- 0.0591" (1.5 mm) Vertical: +/- 0.0393" (1 mm)
FLASH Memory (User Available)	1 MB
DRAM Memory (User Available)	1 MB

Label/Tag Specifications

Label/Tag Width		1" to 4.25" (25.4 mm to 108 mm) 1" to 2.25" (25.4 mm to 57 mm) for tag stock
Label/Tag Length		0.5" to 22" (13 mm to 559 mm) with standard memory
Interlabel Gap		0.08" to 0.16" (2 mm to 4 mm) 0.118" (3 mm) recommended
Label/Tag Thickness		.003" to .007" (.08 mm to .18 mm) .003" to .0053" (.08 mm to .135 mm) for cutter option
Label Roll Size	Max. Outer Diameter	5" (127 mm)
	Inner Core	1" (25.4 mm) or 1.5" (38 mm)
Media Requirements		<ul style="list-style-type: none"> ✓ Use Zebra-brand direct thermal media that is outside wound. Media may be reflective (black mark) sensing or transmissive sensing, die-cut, notched, or continuous. ✓ For die-cut labels, use only full auto dies. ✓ Notched media must have a 0.5" (13 mm) wide x 0.094" (2.4 mm) long cutout located in the center of the roll. The reflective media black marks must be located in the center of the roll. <p>Minimum Black Mark Dimensions:</p> <ul style="list-style-type: none"> ✓ Mark width: 0.5" (13 mm) centered and perpendicular to the edge of the media. ✓ Mark length: 0.094" (2.4 mm) parallel to the bottom edge of the media.

Font/Bar Code Specifications

Fonts Available	<ul style="list-style-type: none"> ✓ CG Triumvirate Bold Condensed scalable smooth (0) ✓ Zebra fonts A-H, GS, P-V ✓ IBM Code Page 850 International Symbols 	
Bar Codes Available (1D)	<ul style="list-style-type: none"> ✓ Codabar (supports ratios of 2:1 to 3:1) ✓ Code 11 ✓ Code 128/USD 8 (supports serialization in all subsets and UCC Case Codes) ✓ Code 39 (supports ratios of 2:1 to 3:1) ✓ Code 93 ✓ EAN 8/JAN 8 ✓ EAN 13/JAN 13 ✓ EAN 14/UPC-A 	<ul style="list-style-type: none"> ✓ Industrial 2 of 5 ✓ Standard 2 of 5 ✓ Interleaved 2 of 5 (supports ratios of 2:1 to 3:1, Modulus 10 Check Digit) ✓ LOGMARS ✓ MSI ✓ Plessey ✓ POSTNET ✓ UPC-E ✓ UPC/EAN Extensions
Bar Codes Available (2D)	<ul style="list-style-type: none"> ✓ Codablock ✓ Code 49 ✓ Data Matrix ✓ MaxiCode 	<ul style="list-style-type: none"> ✓ MicroPDF417 ✓ PDF 417 ✓ QRcode
Rotation Angles	0°, 90°, 180°, and 270°	

Physical/Environmental/Electrical Specifications

Physical Size (L x W x H)		8.5" x 7.6" x 6.6"	216 mm x 193 mm x 167 mm
Weight	Printer	3 lbs.	1.4 kg.
	Shipping	9 lbs.	4.1 kg.
Temperature Range	Operating	40° to 105° F	5° to 41° C
	Storage	-40° to 140° F	-40° to 60° C
Relative Humidity	Operating	10% to 90% (non-condensing)	
	Storage	5% to 95% (non-condensing)	
Electrical		External 90-264 VAC, 47-63 Hz universal power supply. Regional line cords are available.	

Agency Approvals

- UL 544 Medical Equipment Standard Part 42.5
- CSA 22.2 No. 950-95 Canadian Safety Standard
- IEC 950/EN 60950 International Safety Standard
- FCC Class B
- UL 1950 Domestic Safety Standard, 3rd Ed.
- Canadian DOC Class A
- EN50082-1:1997 International Immunity Standard
- EN55022 Class B European Electromagnetic Radiation Standard
- EN61000-3-2, 3 Powerline Disturbance
- AS/NZS 3548 Australia EMC
- CE Compliant
- EMC Taiwan
- CB Scheme Documents

Options

- Peel-off
- Cutter
- Linerless
- 4 MB FLASH memory
- 8 MB FLASH memory
- Real time clock with 4 MB FLASH
- Real time clock with 8 MB FLASH
- Power rewinder, 110 VAC
- Power rewinder, 230 VAC

For details, call your authorized reseller.

Serial (RS-232) Connector Technical Information

Pin No.	Description
1	Not used
2	RXD (receive data) input to the printer
3	TXD (transmit data) output from the printer
4	DTR (data terminal ready) output from the printer -- controls when the host may send data
5	Chassis ground
6	DSR (data set ready) input to the printer
7	RTS (request to send) output from the printer -- always in the ACTIVE condition when the printer is turned on
8	Not used
9	+5 V @ 0.75 A fused



NOTES: *The maximum current available through the serial and/or parallel port is not to exceed a total of 0.75 Amps.*

When XON/XOFF handshaking is selected, data flow is controlled by the ASCII control codes DC1 (XON) and DC3 (XOFF). The DTR control lead will have no effect.

Interconnecting to DTE Devices

The printer is configured as data terminal equipment (DTE). To connect the printer to other DTE devices (such as the serial port of a personal computer), use an RS-232 null modem (crossover) cable.

[Figure 31](#) shows the required cable connections.

Interconnecting to DCE Devices

When the printer is connected via its RS-232 interface to data communication equipment (DCE) such as a modem, a STANDARD RS-232 (straight-through) interface cable must be used. [Figure 32](#) shows the connections required for this cable.

Connecting the Printer to a DTE Device

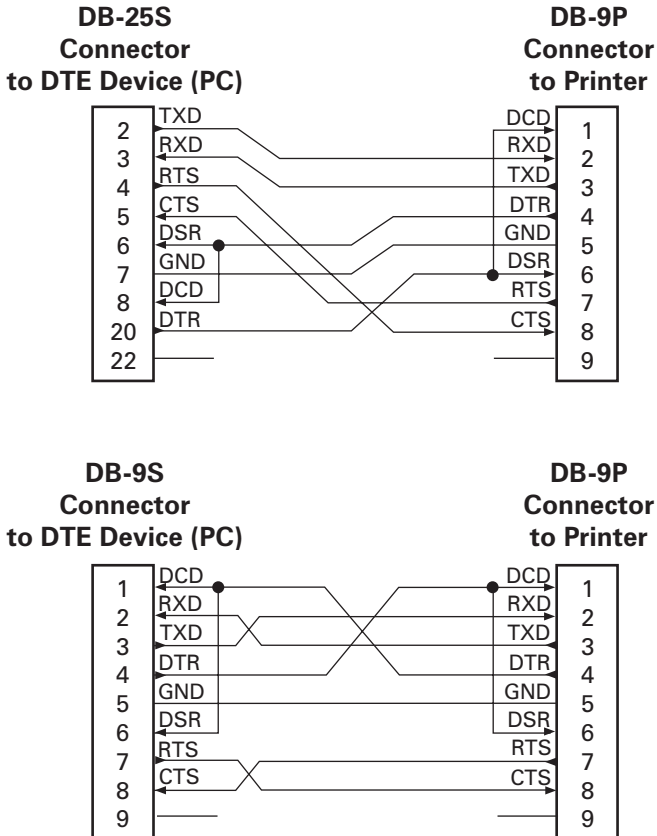

Figure 31

Connecting the Printer to a DCE Device

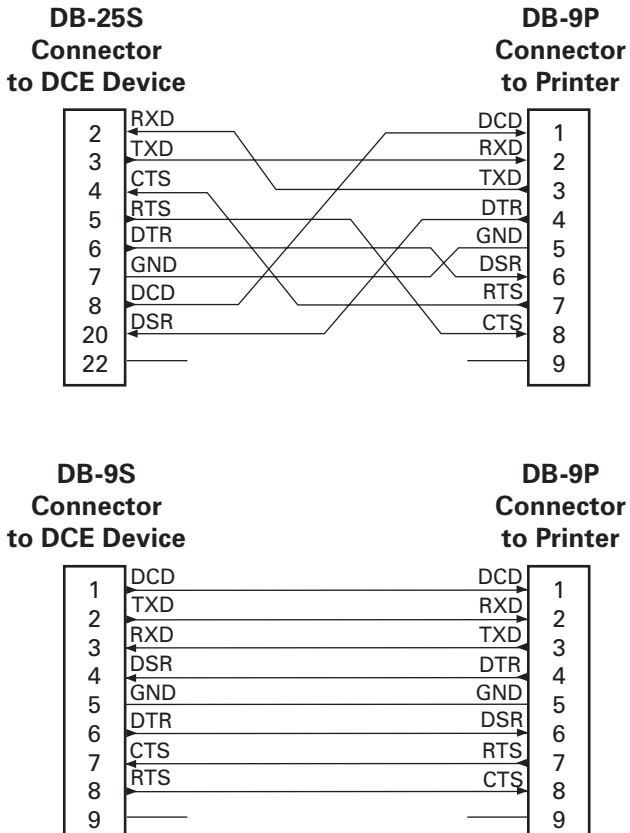

Figure 32

Parallel Interface Technical Information

Pin No.	Description
1	nStrobe/Host Clk
2-9	Data Bits 1-8
10	nACK/PtrClk
11	Busy/Per Busy
12	PError/ACK Data Req.
13	Select/Xflag
14	nAuto Fd/Host Busy
15	Not Used
16 & 17	Ground
18	+5 V @ 0.75 A Fused
19-30	Ground
31	nInit
32	nFault/nData Avail.
33 & 34	Not Used
35	+5V through 1.8 K Ω Resistor
36	nSelectin/1284 active



NOTE: *The maximum current available through the serial and/or parallel port is not to exceed a total of 0.75 Amps.*

Index

A

Adjustments	
Print darkness	23
Print speed	23
Print width	23
Agency approvals	44
Auto calibration	18
Autobaud	22

C

Calibration	
Auto	18
Manual	28
Cleaning	
Cutter	33
Exterior	33
Interior	33
Peel bar	33
Platen roller	33
Printhead	33
Tear bar	33
Communications parameters, setting	22
Communications diagnostics	30
Configuration label	29
Cutter mode	14

D

Damage, shipping	2
Darkness, adjusting	23
DCE devices, interconnecting	45
Defaulting the printer	30
DTE devices, interconnecting	45

F

Factory defaults, resetting	30, 31
Fanfold media	17
Feed button	19
Feed button modes	31

I

Inspection	2
----------------------	---

L

Loading the media	
Cutter mode	14
Fanfold	17
Peel-off mode	9
Tear-off mode	5
Lubrication	33

M

Maintenance parts	35
Manual calibration	28
Media loading	
Cutter mode	14
Fanfold	17
Peel-off mode	9
Tear-off mode	5

O

Operator controls	19
Options	44

P

Parallel connector pinouts	48
Parts list	35
Peel-off mode	9
Pinouts	
Parallel	48
Serial	45
Power switch	19
Print darkness, adjusting	23, 31
Print speed, adjusting	23
Print width, adjusting	23, 31
Printhead, replacing	36

R

Recalibrating the printer	29
Repair parts	35
Replacing the printhead.	36
Reporting damage, shipping	2
Resetting the factory defaults	30, 31

S

Serial connector pinouts	45
Set communications (^SC)	22
Specifications	
Font/bar code	43
Label/tag	42
Physical/environmental/ electrical.	43
Printing	41
Status LED	19, 25

T

Tear-off mode	5
Troubleshooting.	25
Troubleshooting tests	29

U

Unpacking	2
---------------------	---

Z

ZPL II	23
ZPL II Programming Guide	1, 23

Free Manuals Download Website

<http://myh66.com>

<http://usermanuals.us>

<http://www.somanuals.com>

<http://www.4manuals.cc>

<http://www.manual-lib.com>

<http://www.404manual.com>

<http://www.luxmanual.com>

<http://aubethermostatmanual.com>

Golf course search by state

<http://golfingnear.com>

Email search by domain

<http://emailbydomain.com>

Auto manuals search

<http://auto.somanuals.com>

TV manuals search

<http://tv.somanuals.com>