



C Series-3G Loudspeakers Owner's Information



American Acoustic Development LLC



C Series-3G Loudspeakers

Owner's Information

Introduction

Thank you for choosing  loudspeakers. Their refined and natural sound character will greatly enhance your listening pleasure. Great attention to detail has gone into the design and manufacturing of  loudspeakers, which are built with only the finest materials. They will provide many years of excellent performance.

Since 1998, C Series speakers have enjoyed tremendous popularity around the world. Our relentless pursuit for perfection at affordability has led to the creation of C Series-3G, speakers one step further in performance than the original Ci Series. To accomplish this mission, a new line of dedicated transducers have been painstakingly developed: the high-power, long-stroke woofers featuring laminated cones of polypropylene and natural fibers, ferro-magnetic liquid cooled and damped mid-range unit which provides unmatched dynamic and natural tonality, and the titanium dome tweeter (same tweeter used in our high end S Series) with crystalline sonic purity and smoothness. Computer aided crossover network designs in combination of extensive listening sessions provide seamless transition between these proprietary transducers, giving the listener not reproduced sound from a loudspeaker but more a window of the live performance.

More features of the C Series-3G include:

1. Smooth and extended frequency response. The  speakers are able to produce wide musical range from bass through mid-range frequencies and up to the highest frequency beyond human limits.
2. High acoustic output. This means that modest amplifiers will be able to produce acoustical levels normally associated with amplifiers with substantially more rated power.
3. Superior transient performance. The speakers are able to give definition to percussion sound such as piano, drums and triangles, all of which will be reproduced with startling clarity.

4. Precise stereo imaging. Close tolerance pair matching of drivers ensure a stable stereo image. Minimal phase crossovers ensure great depth and width of the sound stage.
5. Compatibility and flexibility. The C Series-3G includes many models of bookshelf, centre channel, floor standing, rear surround speakers and subwoofers in various sizes to provide maximum flexibility for different home theatre and stereo application. No matter what your requirements are and type of room you have, a custom designed system by using speakers from the C Series-3G will meet your personal needs.

C Series-3G Family Products

Refer to Table 1 for specifications

C-204

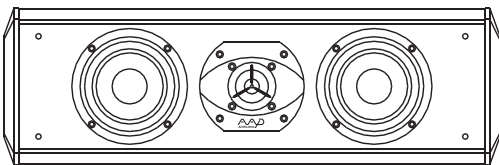

C-305

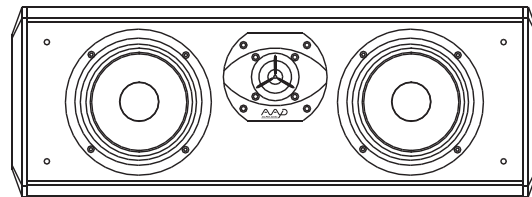

C-11

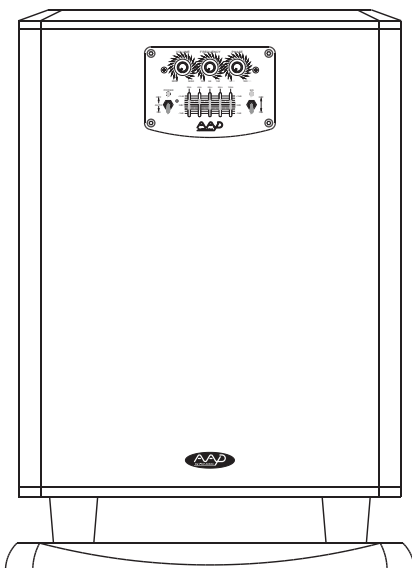

C-150

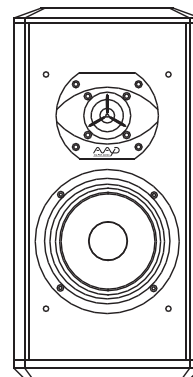

C-44W

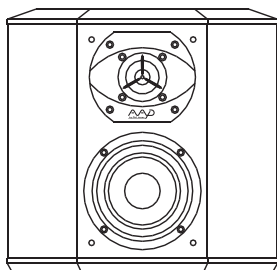

C-44

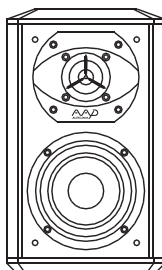

C-45

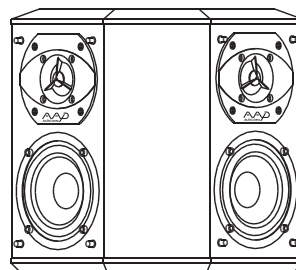

C-880

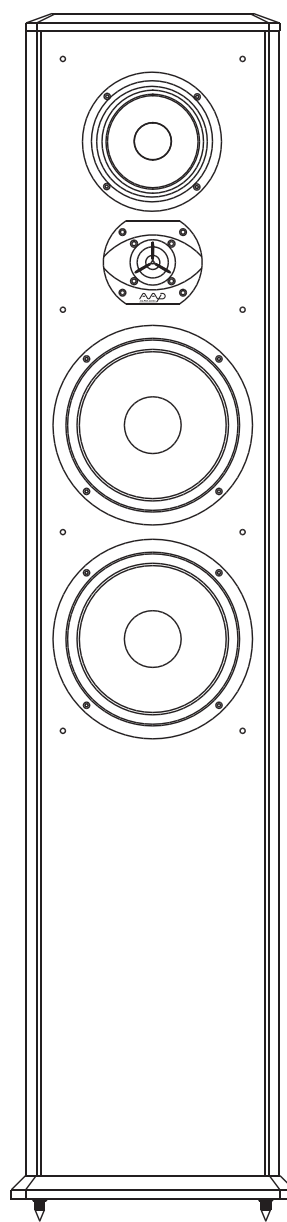

C-660

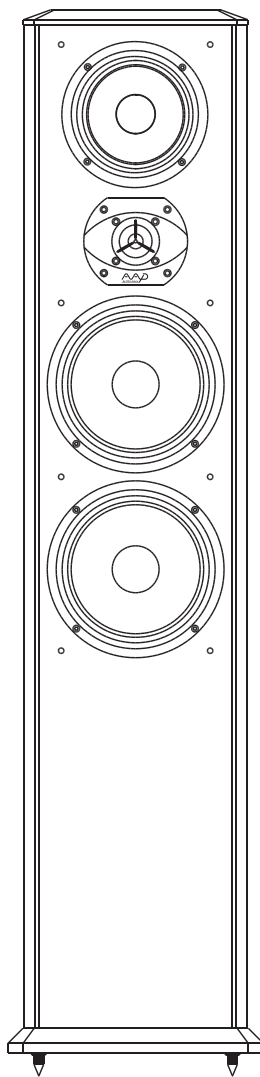

C-550

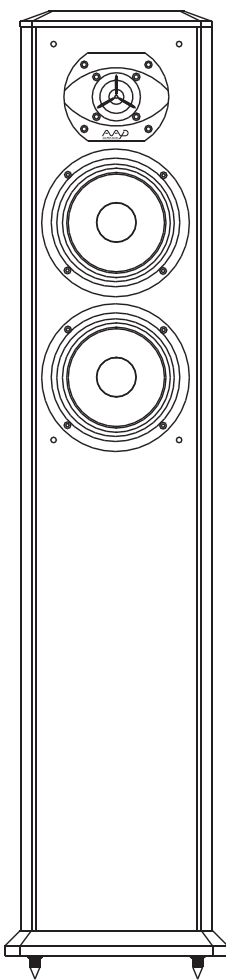

Placement

Two Channel Stereo Application

For stereo listening, you may choose any one pair of bookshelf or floor standing model. The size of speakers should be determined by the size of your living space so that they can provide sufficient volume. The two loudspeakers should be placed an equal distance from your listening position.

Bookshelf systems will also benefit from placement on stands or shelves. The C Series-3G stands are designed to match the bookshelf speakers functionally and aesthetically.

Placing the loudspeakers in corners or against a wall will result in the strongest (but not necessarily the most accurate) bass. For the best stereo imaging, we recommend that the systems be placed so that the high frequency transducers are as close as possible to the ear level of a seated listener.

Every room has different acoustic characteristics and people have different tastes in sound. You should experiment to find out the placement position that satisfy your personal tastes.

Home Theater Application

To get the best surround sound from your C Series-3G speakers, we recommend to position the speakers at the same distance from the listening position.

The centre speaker, however, may be moved closer, but not beyond the straight line connecting the two front speakers. The rear speakers may also be closer to listening position than the front speakers to suit the configuration of your room.

Notes:

- Do not place the centre or rear speakers farther away from the listening position than the front speakers.
- When mounting the rear speakers on side walls perpendicular to the listening position they should be placed 60-90cm above the listener's ear level at sitting down position.

Depending on the shape of your room (etc.), you may wish to place the rear speakers behind you instead of on the side walls. In this case, you can use a pair of large floor standing speakers matching your front speakers.

Connections

Note: Make sure your amplifier is off and disconnected from power while you are connecting speakers to amplifier. Turn your amplifier on only after you check and make sure speakers are properly connected.

Two Channel Stereo Application

Connections are made at the terminals located on the back of the loudspeaker system. The terminals accept spade plugs, bare wire or banana plugs. For best results, use high quality speaker cables.

All C Series-3G loudspeakers have 4 gold plated binding post for single or bi-wiring options.

Single Wiring

This method uses only one pair of cables to connect each speaker to the amplifier. (see Fig. 1).

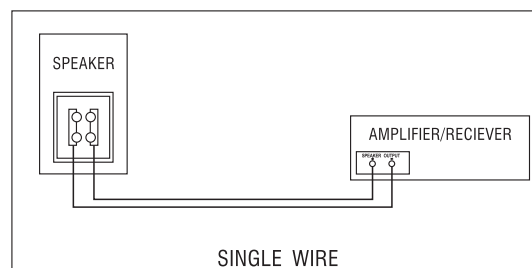

FIG. 1

For each channel, the red terminal on the loudspeaker should be connected to the red or (+) loudspeaker connection terminal on the receiver or amplifier. The black terminal on the loudspeaker should be connected to the black or (-) loudspeaker connection terminal on the receiver or amplifier. Connecting the loudspeakers in this manner ensures that they will be in phase; that is work together rather than in opposition. Connecting the loudspeakers out of phase will not damage them, but will result in less bass and poor imaging.

Note: make sure the metal links are in place.

Bi-Wiring

Bi-wiring increases the flow of current and will usually improve the sound quality. This method uses two pair of cables: one pair for the upper two terminals and one pair for the bottom two terminals (see Fig. 2).

Connect the speakers to amplifier the same manner as you do single wiring.

You will need one pair of cable for each speaker in the system.

Note: remove the metal links.

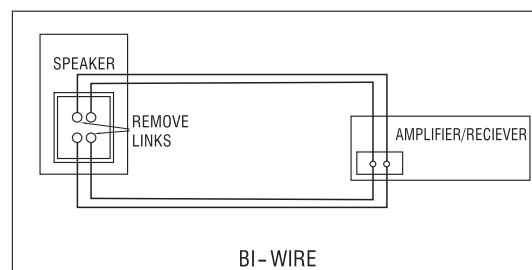

FIG 2

Home Theater Application

Adding centre and rear speakers to the left and right channels will enhance the surround effects of motion pictures. If you choose smaller models, an active subwoofer is essential for adequate bass reproduction.

On the back panel of your AV amplifier, locate the Front Speaker, Centre Speaker, and Rear Speaker terminals.

Using the same method as connecting two channel stereo speakers, connect left and right, centre, and rear speakers to the corresponding terminals on the AV amplifier.

Again, be sure to match the speaker cables to the appropriate terminals on the components: (+) to (+) and (-) to (-) to ensure sufficient bass and clear imaging.

Adding a subwoofer to your home theater system will greatly improve bass performance and provide fuller impact from motion pictures. We recommend C-11 subwoofer for smooth transition and configuration.

C-11 Powered Subwoofer Owner's Information

Important Instructions

1. Read your owner's manual carefully before using the product. Retain this manual for future reference.
2. The subwoofer should be placed at a ventilated, dry and cool location, away from any heat sources such as radiators or amplifiers. Do not obstruct the amplifier in the C-11 from ventilation. It is necessary that air can flow around the finned heat sink on the rear panel of the amplifier.
3. Do not use the subwoofer near water or expose it to rain or moisture.
4. Always unplug the power cord first when making connections. Switch power on only after you check and make sure all connections are made correctly.
5. Unplug the power cord from the outlet when you are not going to use the subwoofer for a long period of time.
6. To clean, unplug the power cord from the outlet first. Use a damp cloth only to wipe dust off the surface. Do not use any liquid cleaners.
7. Do not put coffee cups or other objects on top of the cabinet. They can be shaken off when the subwoofer is in operation as it can produce a lot of vibration.

Introduction

C-11 is a home theater subwoofer equipped with a build-in equalizer. The  5-band equalizer is a powerful tool in correcting anomalies of subwoofers caused by room acoustics. It will greatly increase subwoofer performance when used properly.

In the real world, subwoofers generally do not have a flat frequency response. Only in ideal conditions such as open air or large anechoic test chambers do they have a perfect response measurement. When a subwoofer is played in a listening room, the bass frequencies can be up or down 10 dB from the ideal response. The sound can have a “boomy” or ill-defined bass that will impair the overall musical performance. The  5-band equalizer is designed to control offending bass notes that “booms” louder than they should. It features precisely aligned 1/3-octave equalization filters that are only found on the best professional audio equipment.

The cabinet has been designed using extensive computer modeling for the best possible alignment between driver and box. Coupled with two high excursion

proprietary 8" drivers, the C-11 produces clean, powerful and controlled bass. Three large rear-firing vents ensure ventilation of both driver and amplifier for cool running at high power. The vent's large bore and "gas flowed" cross-section reduces air turbulence that causes audible distortion.

Functions and Connections

Please refer to Fig. 3 (Front control panel) and Fig. 4 (Back panel) for functions on C-11 Subwoofer amplifiers

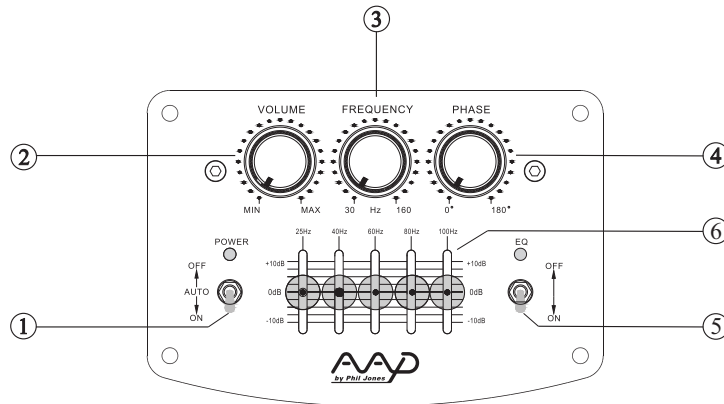

Fig. 3

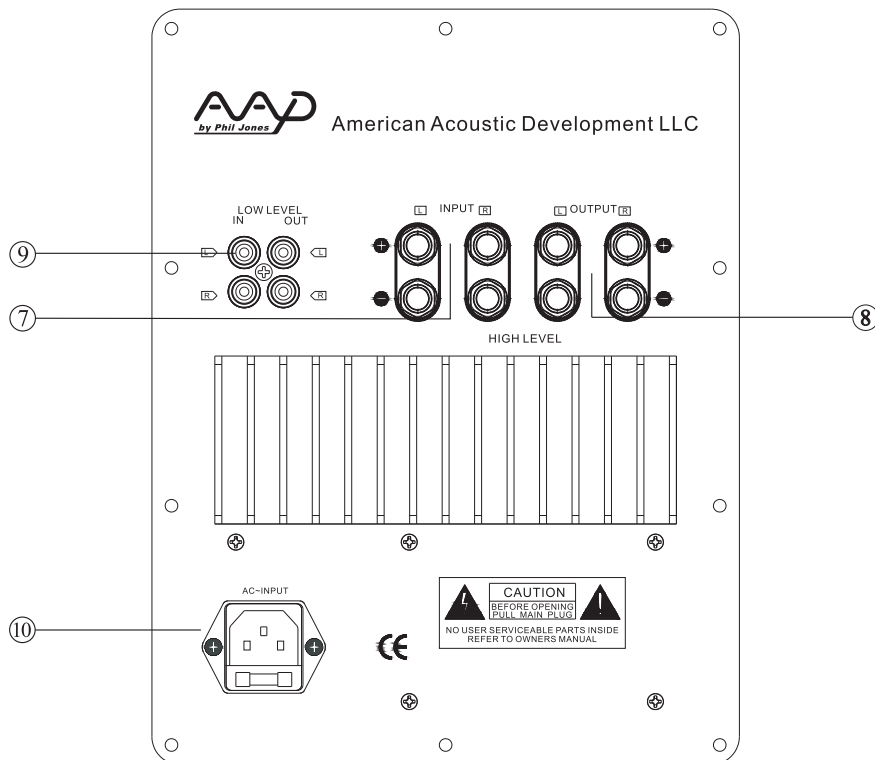

Fig. 4

① **Power switch on/off**

Upper position: Power on

Lower position: Power off

Middle position: Auto on

At this position the subwoofer amplifier is in a stand by mode, awaiting an input signal. When there is no signal, the amplifier is shut down. As soon as the signal appears, the amplifier switches on. If signal is absent, the amplifier will shut down automatically after a pre-determined period of time. The power indicator is red when the switch is at OFF position, and green when the switch is at ON or AUTO position.

② **Volume Control**

Use this control to balance the level of the woofer with the level of your main speakers.

③ **Crossover Frequency control**

If you are using small loudspeakers (4" to 6" woofers) in your main system, you will need to set the crossover frequency at a high position (100 to 160 Hz). If your main speakers have larger woofers (8" and above) you will need to set the crossover frequency to much lower position (40 to 80 Hz). Generally, the larger the speaker, the greater the low frequency output will be. If the frequency control is set too high, the bass will appear "boomy" due to outputs of subwoofer and main speakers overlapping each other. If it is set too low, the bass will be ill defined and the subwoofer will sound detached from the rest of the system.

④ **Phase Control**

Use this control to determine the best possible bass performance of your system. There can be interference between your main speakers and subwoofer at the frequency where they cross over due to placement, room acoustics and type of main speakers used. By carefully positioning the subwoofer in the room in combination with the level and crossover control, you should be able to get a seamless transition between your main speakers and subwoofer. Start with the full anticlockwise 0° position. This means that the subwoofer will push out positive pressure wave corresponding to a positive electrical input. The 180° full clockwise position inverts this so the subwoofer will put out a negative

pressure wave. You can use this position if you are unable to get a good integration between the subwoofer and main speakers.

⑤ **Equalizer on/off**

At “off” position, the amplifier will function normally without the effect of the  5-band equalizer.

⑥  **5-band Equalizer**

Please refer to “Setting up EQ for the Room”

⑦ **High Level Inputs L&R**

These inputs should be connected to the left and right speaker terminals of your amplifier/receiver, if you intend to connect the subwoofer using this option instead of the low-level RCA input connections.

⑧ **High Level Output L&R**

You could connect your main speakers from the subwoofer amplifier instead of the main amplifier/receiver. Use this option if you are connecting the subwoofer up via the High Level Input.

CAUTION! Do not use both low level and high level connection methods simultaneously. This may cause damage to the subwoofer and your amplifier/receiver.

⑨ **Low level Input & Output**

Connect this to the pre-amp output of your amplifier/receiver. If you do not have a pre-amp output or a power amplifier input, you can connect up the subwoofer using the Low Level Input/Output utilizing a tape input/output amplifier/receiver. Connect the tape output to the Low Level Input on the subwoofer, then connect the tape input to the Low Level Output on the Subwoofer. To switch the subwoofer into the circuit, switch the tape monitor input on your amplifier/receiver.

Use this in conjunction with your receiver/amplifier. Connect this output to the power amplifier input of your amplifier/receiver.

⑩ **Power input socket and Fuse**

For continued protection, replace only with same type fuse. (A spare fuse is enclosed for replacement.)

Connection

Please see diagrams below for different method of connecting the subwoofer to your main amplifier/receiver. It may be possible to use alternative connecting methods. Please refer to the owner's manual of your amplifier/receiver or seek professional advice from your retailer or installer.

CAUTION! Before switching power on, please make sure all connections are made properly, i.e., positive to positive, negative to negative.

Connection method 1:

Connecting the subwoofer using dedicated subwoofer RCA output from receiver (see Fig. 5)

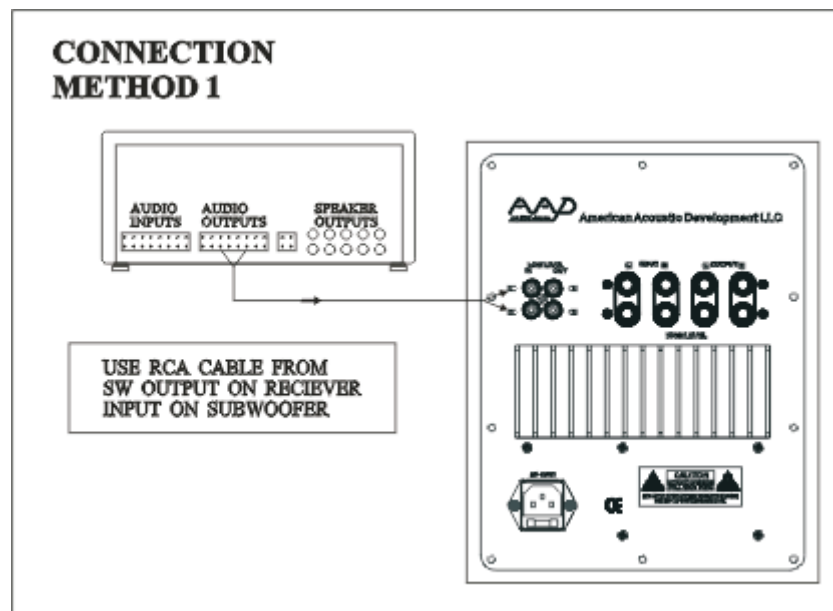

Fig. 5

Connection method 2:

Connecting subwoofer between pre-amplifier outputs and power amplifier inputs (see Fig. 6)

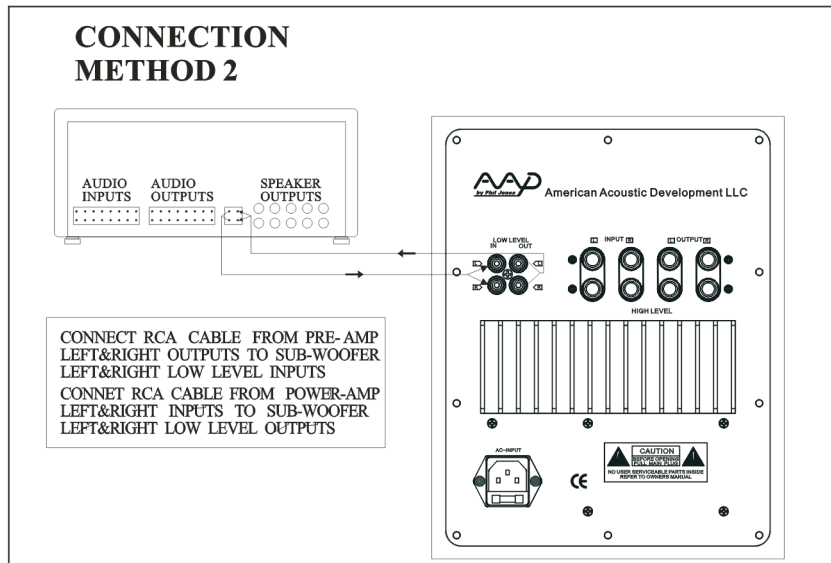

Fig. 6

Connection method 3:

Connecting subwoofer from speaker outputs of receiver (see Fig. 7)

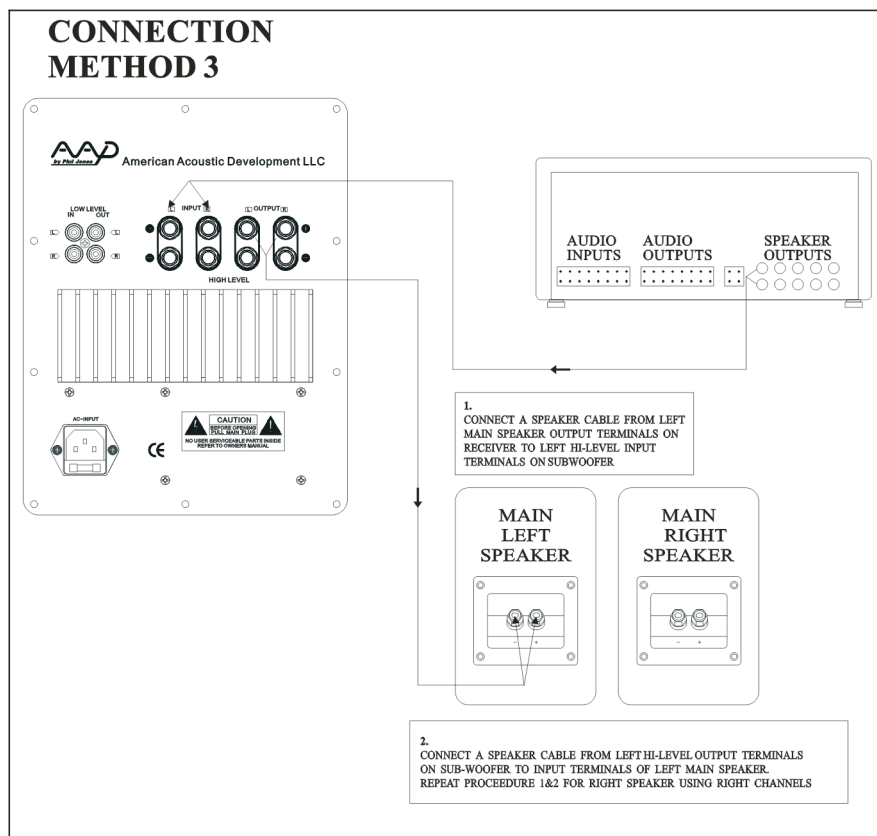

Fig. 7

Setting up EQ or the Room

Play some familiar pieces of music that have prominent bass lines. Start with the EQ switched out and then adjust the EQ filters one by one switching the EQ in and out. It is better to start with the EQ cutting the frequencies and not boosting them. Remember that a 10 dB boost is adding ten times the power at that frequency so it would be easy to overload the system at high power levels with the EQ sliders set at maximum.

Room Size and Room Position

The size of the room and the position of sub-woofer placement will also determine low frequency limit of the subwoofer. So by adjusting the EQ settings, the ideal response can be obtained without having to place the subwoofer in an unpractical location. Small rooms usually add gain to low frequencies, which can be overpowering to the rest of the music. Large rooms need greater low frequency energy to sound balanced. The EQ settings can be adjusted to fit the room size. The 5 band equalizer should be used with great caution. The power levels to the speaker can be boosted by as much as 10 times! So if the subwoofer is running at 100 watts the EQ boost at maximum will try to push the amplifier to an impossible 1000 watts! Although the amplifier and speakers are designed to handle overload conditions it is still possible to cause damage from mis-use.

Placement of Subwoofer

The subwoofer can be placed virtually anywhere in your room without affecting the stereo image of your main speakers. Placing the unit in a corner of the room will yield the greatest bass output but may not provide the best sound, as this position will cause maximum room mode resonance. You can start with this position and then move the subwoofer to different areas until you find the sound satisfactory. The best method is to try different positions. Keep a clearance of 100mm/4" from the wall or furniture to provide best performance.

General Care

The loudspeaker cabinet may be cleaned with a slightly damp cloth. Grilles should be kept on the speakers to protect the drive units when the speakers are not being played. Never use any solvents to clean any part of the system.

The grille is held in place by pins near the edges. To remove the grille, grasp it by both top and bottom edges and pull gently. To replace the grille, reposition it carefully and press gently at the corners. Do not push on the center area of the grille. Keep the grille free of dust and dirt. To clean, remove the grille from the cabinet and vacuum lightly.

Warranty & Service

The C-3G Series speakers come with warranty period of 3 years, starting from the date of purchase. This warranty is provided to original owner, and covers defect in materials or workmanship that occurs in normal use. This warranty excludes damage that results from abuse, misuse, accidents, shipping, or repairs or modifications by anyone other than authorized  representatives. The warranty is void if serial number has been removed.

Should you need service on your speakers, please bring it to the dealer whom you purchased from along with sales slip.

If this is not possible, call or write to:

American Acoustic Development LLC
8559 Page Ave, St. Louis,
MO 63114, USA

Tel: 314-814-3383
Fax: 314-628-9941
E-mail: info@aadsound.com
www.aadsound.com

C series-3G Specification

Standard Cabinet Finish: Cherry/Classic Black(viny1)

Model	Cabinet Type	Tweeter	Mid-Range	Woofers	Shielded Drivers	Impedance	Sensitivity (dB)	Recommended Power(watt)	Cabinet Dimension(mm)	Weight(Kg)	Frequency Response(Hz-KHz)
C-150	Bookshelf	1		1x5 "	Yes	8Ohm	89	20-100	377x191x251	8.5	45-20
C-550	Floor Standing	1		2x5 "	Yes	6Ohm	90	20-150	940x222x282	18.5	35-20
C-660	Floor Standing	1	1x5 "	2x6.5 "	No	6Ohm	91	20-200	1050x257x322	23.5	30-20
C-880	Floor Standing	1	1x5 "	2x8 "	No	6Ohm	92	20-250	1253x299x377	31	25-20
C-204	Center Channel	1		2x4 "	Yes	8Ohm	88	20-100	156x494x195	7.5	70-20
C-305	Center Channel	1		2x5 "	Yes	6Ohm	89	20-150	191x529x250	12	40-20
C-44	Rear Surround	1		1x4 "	Yes	8Ohm	87	20-80	260x156x151	4	80-20
C-44W	Rear Surround	1		1x4 "	No	8Ohm	87	20-80	259x263x91	3.75	80-20
C-45	Rear Surround	2		2x4 "	No	6Ohm	89	20-100	259x287x143	5.75	50-20

Table 1

C-11 Specifications

Amplifier type	Solid state Class A/B
Power	160 watts continuous into 4 Ohm
Woofers	Proprietary 10" diaphragm Aluminum Cone / 60 Az magnet / 2" voice coil
Frequency response	30 Hz to 160 Hz +/- 3 dB
Electronic crossover	Continuously variable from 30 Hz to 160 Hz 24dB/octave
Phase control	Variable 0° - 180°
5 Band EQ	±10dB at 25Hz、40Hz、60Hz、80Hz、100Hz
Inputs	Low level RCA 300mv sensitivity in both channel High level 5 way binding post 10v sensitivity
Outputs	Low level RCA High level 5 way binding post
Enclosure type	Vented bass reflex
Cabinet dimensions	514(H) x375 (W) x445(D) mm
Net weight	23.5 Kg
Finish	Cherry/Classic Black(viny1)



American Acoustic Development LLC
8559 Page Ave, St. Louis,
MO 63114, USA

Tel: 314-814-3383
Fax: 314-628-9941
E-mail: info@aadsound.com
www.aadsound.com

Free Manuals Download Website

<http://myh66.com>

<http://usermanuals.us>

<http://www.somanuals.com>

<http://www.4manuals.cc>

<http://www.manual-lib.com>

<http://www.404manual.com>

<http://www.luxmanual.com>

<http://aubethermostatmanual.com>

Golf course search by state

<http://golfingnear.com>

Email search by domain

<http://emailbydomain.com>

Auto manuals search

<http://auto.somanuals.com>

TV manuals search

<http://tv.somanuals.com>