



EZScan 2000 Document Scanner



Model: EZScan 2000

QuickGuide

English

www.adesso.com

1

LIMITED WARRANTY

Adesso provides a one year limited warranty for all of its products against defects in material and workmanship.

During this period, Adesso will repair or replace any product which proves to be defective. However, Adesso will not warranty any product which has been subject to improper freight handling, shipping abuse, neglect, improper installation or unauthorized repair. The warranty will not cover products installed with components not approved by Adesso and products where the sealed assembly trace has been broken.

If you discover a defect, Adesso will, at its option, repair or replace the product at no charge to you provided you return it during the warranty period with freight charges pre-paid to Adesso. Before returning any product, you must obtain a Return Merchandise Authorization number (RMA). This RMA # must be clearly marked on the outside of the package you are returning for warranty service. Be certain to also include your name, shipping address (no PO Boxes), telephone number, and a copy of the invoice showing proof of purchase in the package.

SUPPORT

We have listed most of our FAQ's (Frequently Asked Questions) at: <http://www.adesso.com/faqs.asp>. Please visit our FAQ Service & Support pages before you contact our E-mail or Telephone Support.

Email Support: If our FAQ's do not help you resolve your issues, please email support@adesso.com

Telephone Support:
Toll Free: (800) 795-6788
9:00AM to 5:00PM PST Monday - Friday

2

INTRODUCTION

The Adesso EZScan 2000 Document Scanner is the best companion for the busy business traveler because it quickly and easily scans and converts any printed document into a digital file for instant sharing and storing. With the touch of a button scan business cards, checks, identification cards, photographs, letters, legal size documents and much more. Instantly, your document will be converted to a digital file (JPG or PDF) for sharing, storing or editing. The EZScan 2000 also comes equipped with NewSoft Presto! PageManager software for file editing; ABBYY FineReader 9.0 Sprint software to extract text from scanned files with the Optical Character Recognition (OCR) function; and Hotcard Bizcard Finder 3.0 software to organize scanned business cards electronically. Along with all these great features the EZScan 2000 is also lightweight and portable, so you can take it with you anywhere to convert all your important printed documents to digital files.

SPECIFICATIONS

Scanning Type: Advanced Color Contact Image Sensor
Optical Resolution: 600 x 600 DPI
Scan Mode: Color: 48-bit input; 24-bit output
Grayscale: 16-bit input; 8-bit output, Black and White: 1-bit
Scan Area: Max 8.5 x 36" (216 x 910 mm), Min 0.5 x 0.5" (12.7 x 12.7mm)
Scan Speed: Approx 20 sec at 300 DPI, A4 Size, Grayscale
Paper Thickness: Up to 0.4mm
File Formats: JPG, TIFF, PNG, BMP & PDF
Action Button: PDF, SCAN
Scan Method: Single Pass
Protocols: TWAIN Compliant
Interface: USB
Power Supply: USB Bus Power 5V/0.5A

REQUIREMENTS

Hardware: IBM Compatible PC with Pentium III 1GHz or faster CPU
Memory: 512 MB RAM
1GB free HDD Space
Operating System: Windows® 7, Windows® Vista, Windows® XP and Windows® 2000
Connectivity Interface: USB
Others: High Color Graphic Card (VGA or higher)
CD-ROM (for Software Installation)

3

Package Contents

1. EZScan 2000 Document Scanner



2. Mini USB Cable



3. Quick Start Guide



4. Installation CD



5. Calibration Sheet



6. Cleaning Paper



7. Travel Pouch



8. Wall Holder



9. (2) Screws



4

Description

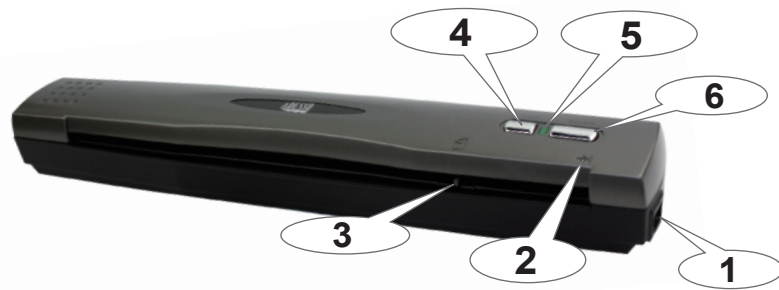

- USB port:** Connects scanner to your computer via included USB cable.
- Alignment Arrow:** Always align the edges of your documents to this arrow sign.
- Page Feed Slot:** Feed the document into the scanner from this direction, you can feel the document being grabbed by the scanner.
- PDF Button:** Scans documents into PDF format.
- LED Indicator:** Light indicates scanner is connected and power is on.
- Scan Button:** Scans document into pre-selected image format.

5

Installation

- Plug the smaller end of the included USB cable to the back of the scanner, and plug the bigger end of the USB cable to the USB port on your computer.

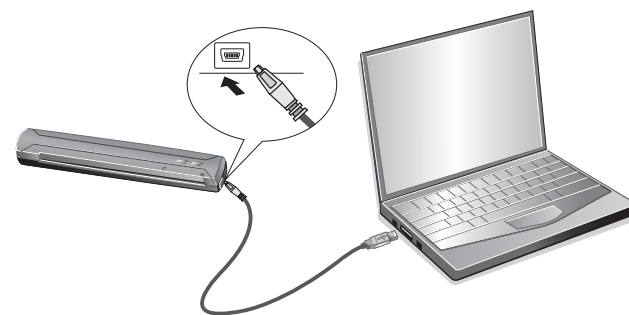

- Insert the Installation CD into your CD-ROM drive



Note: If the Installation Wizard does not start and display automatically, please double click "install.exe" from the root of CD-ROM.

6

Start Scanning

Documents, photo and business card scanning can be performed using the following steps.

- Insert your source (document, photo or business card) faced down into the scanner. Align the source to the arrow sign → on the right side of the scanner.

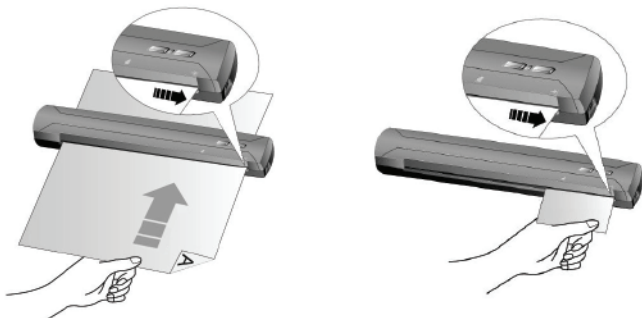

- Press the Scan or PDF Button.
- If the option of "Continuous Scan" is checked, insert additional documents after previous document has been scanned completely.
- When the scan is complete, the scanned image(s) will be saved at the defined file path and sent to the assigned post-processing software (e.g. File, Program, PDF, OCR, Email).

9

How to Clean Scanner

If unusual dots or lines are found in your scanned images, it is very likely that dust particles or other foreign objects are inside the scanner. You may clean the scanner to rectify this problem.

- Insert the special cleaning paper into the page feed slot of scanner.

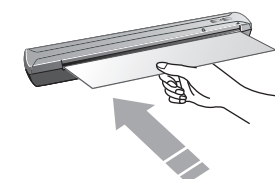

Attention

- Must use the cleaning paper included in package. Store the cleaning paper in a clean place.
- Do not use anything other than our cleaning paper to clean this scanner. Using another sheet will affect the scan quality or even lead to scanner malfunction.

- Press Scan button to start cleaning process. Wait until the cleaning paper scans completely and then cleaning is complete.

10

How to Calibrate Scanner

Calibrate the scanner if scanned image appears with white spots or if color of scanned image varies a lot from original. Calibrating allows you to adjust and compensate for variations that can occur in the optical component over time.

- Insert the special calibration sheet face down into the page feed slot of the scanner.

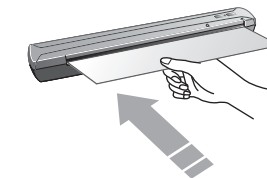

Attention

Please insert the special calibration sheet included with the scanner. Alternatively you may also use any plain white sheet of Letter size (8.5" x 11.69") paper instead; however, the calibration may be less precise than if using the supplied special calibration sheet.

- Click Start > All Programs > Your scanner model name > Calibration Wizard.
- Follow the on-screen instruction to complete the calibration process.

11

Button Configuration

Before performing your first scan via scanner buttons, you are recommended to configure the button settings to your needs and preferences.

Right-click the icon in the Windows® system tray and select "Button Configuration" to select settings.

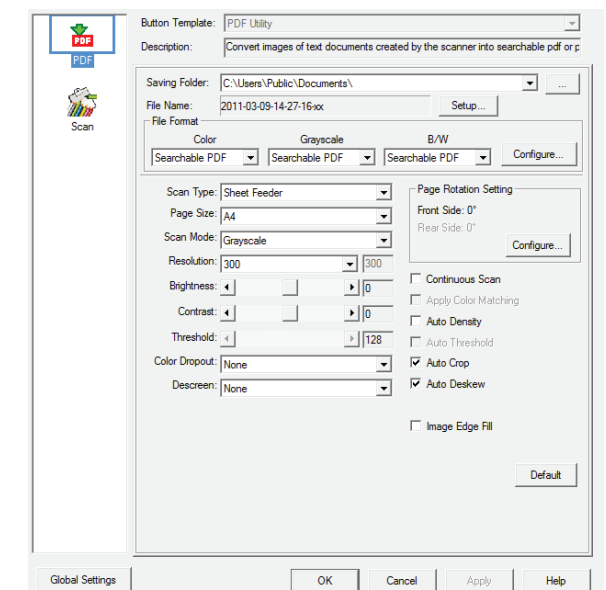

8

Usage & Maintenance Tips

To keep your scanner working smoothly take a moment to review the following maintenance tips.

Caution

- Do not insert any document into the scanner with small objects such as paper clips, pins, staples or any other fasteners.
- Do not insert damp, curled or wrinkled documents into the scanner for scanning. These types of documents can cause paper jams and possibly damage the unit.
- Your scanner operates best in temperatures between 10° C to 40° C (50° F to 104° F).

Note:

For more details about using the scanner, please refer the user guide on the Installation CD.

12

Free Manuals Download Website

<http://myh66.com>

<http://usermanuals.us>

<http://www.somanuals.com>

<http://www.4manuals.cc>

<http://www.manual-lib.com>

<http://www.404manual.com>

<http://www.luxmanual.com>

<http://aubethermostatmanual.com>

Golf course search by state

<http://golfingnear.com>

Email search by domain

<http://emailbydomain.com>

Auto manuals search

<http://auto.somanuals.com>

TV manuals search

<http://tv.somanuals.com>