



LIBRA-02 M / LIBRA-02 HM COPY ROUTER

User's Manual



CONTENTS

Page

1. General Information	3
	+
	+
2. Machine's Description and Purpose of Use	3
	+
	7
	@
3. Safety	9
	C
	D
	D
4. Transport of the machine	12
5. Installation of the machine	12
	,
6. Machine's safety information	14
7. Operation	15
	7
8. Changing the router bit and the drill bits	16
9. Adjusting the air pressure	17
10. Maintenance	19
	C
11. Information about faulty use	19
11. Electric / pneumatic components	20
	,
	D
12. Troubleshooting	21



1. GENERAL INFORMATION

1.1. INTRODUCTION

50) 4B (0: .) 1*#03 0 03 # 40#6) G '#0 1*#0. '# *#
/ 30## 3 3 # H' # 6 *# 4 /63
H #03# /00#* 0# #. #0 40# #040#0#B/ :) 4B#
D H 4#*34# . 1. B
D- 540 *#(# #101 * # 6 *3# ' ** # 10) 4B#
: 01 #B

1.2. DISTRIBUTOR

50) 4B (0: .) 1*#03 0 03 # 40#6) G '#0 1*#0. '# *#
/ 30## 3 3 # H' # 6 *# 4 /63
H #03# /00#* 0# #. #0 40# #040#0#B/ :) 4B#
D H 4#*34# . 1. B
D- 540 *#(# #101 * # 6 *3# ' ** # 10) 4B#
: 01 #B

2. MACHINE'S DESCRIPTION AND PURPOSE OF USE

2.1. MACHINE'S DESCRIPTION

50) 4B (0: .) 1*#03 0 03 # 40#6) G '#0 1*#0. '# *#
/ 30## 3 3 # H' # 6 *# 4 /63
H #03# /00#* 0# #. #0 40# #040#0#B/ :) 4B#
D H 4#*34# . 1. B
D- 540 *#(# #101 * # 6 *3# ' ** # 10) 4B#
: 01 #B



0 3 0# #10 06 : 0# #0' . *# 6() 034 '#0#00.' *# 10
 :.) 1*# *1 10 . #/)(0. '# B(5H 0 0
 -.) 1*# ' 06
 -.) 1*# 230* 6# 1 0
 6 0 '#/0(0#B
 ∴ 0 / 0 0 100 .) 1*# . 34) 1 3
 0 / 4) 1 3
 0B *4* #/ 10 .) 1*# / (6
 90 0. *B 40 * #40*



2.2. TECHNICAL FEATURES

Technical Features (American)						
LIBRA-02 M	800W/1200W 110V/220V 60Hz	14000 rpm	---	90 psi	24x22x57"	160 lb
LIBRA-02 HM	800W 220V/440V 60Hz	14000 rpm	3000 rpm	90-120 psi	26x26x54"	210 lb

Technical Features (Metric)



2.3. OVERALL DIMENSIONS

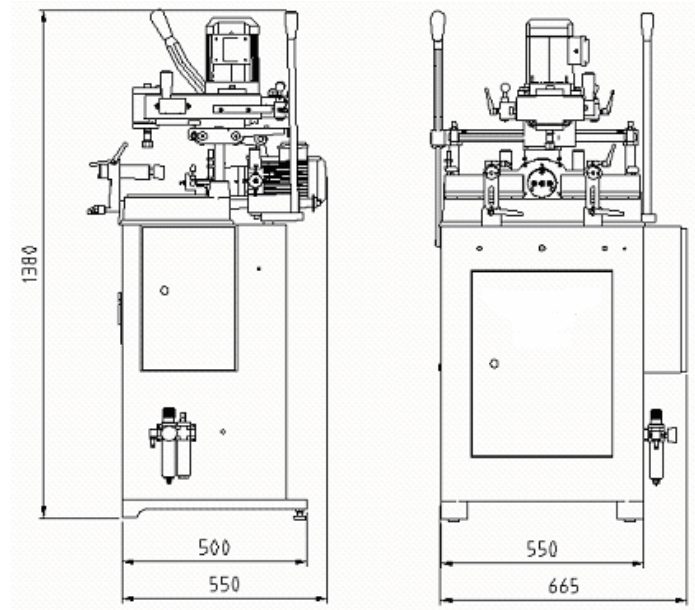

Figure-1

2.4. PART LISTS AND TECHNICAL DRAWINGS

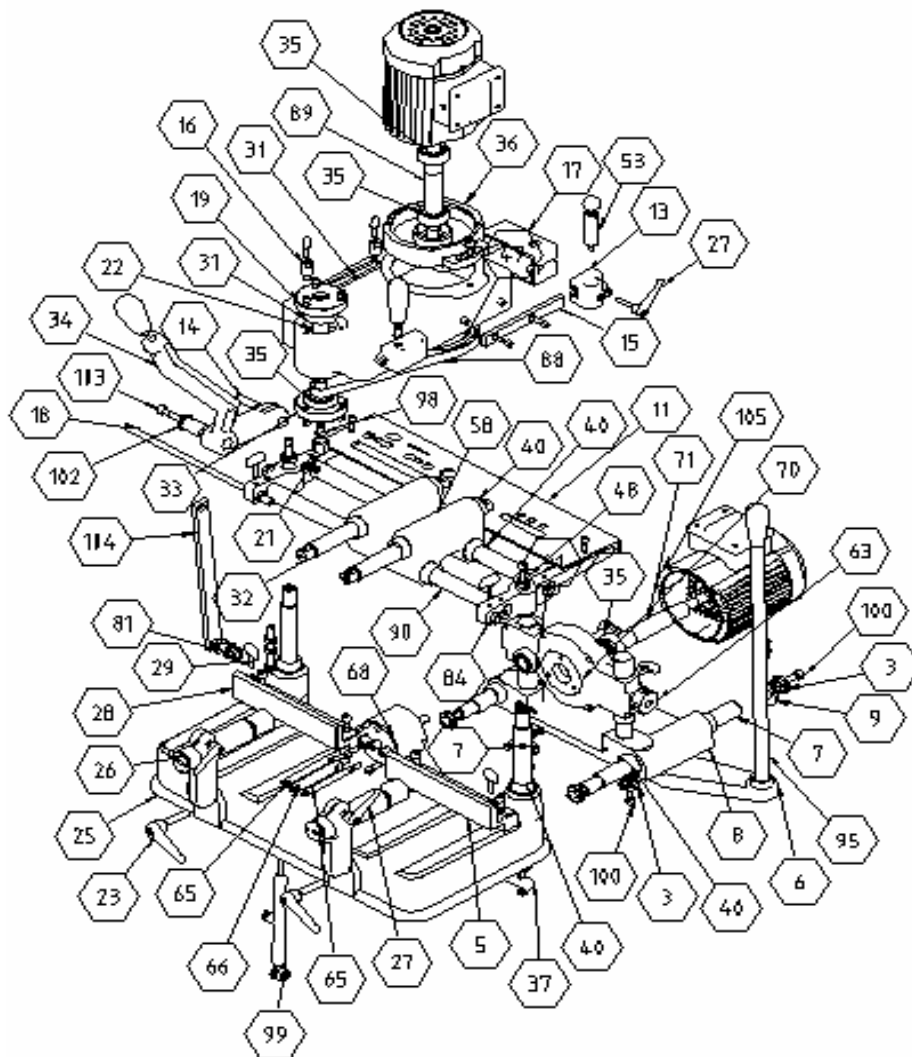

Figure-3



No	STOCK NO / PART NAME	QTY
3	141-093 Washer Diameter 30x8x7	6
5	111-075 Right set square	1
6	111-073 Lower motion arm connection	1
7	144-006 Motion shaft	4
8	111-077 Motion bearing	1
9	224-001 Plastic support	2
11	141-083 Copy template	1
13	111-068 Fixing knob bearing	2
14	141-078 Arm pin	1
15	145-017 Fixing knob bearing fixing bolt	2
16	141-074 Upper limiting pin	2
17	111-081 Rear clamping housing	1
18	141-267 Support shaft	1
19	111-083 Router upper bearing housing	1
21	141-085 Router holder shaft	1
22	142-022 Router shaft	1
23	550-009 Handle 1	2
25	111-051 Table	1
26	550-003 Pneumatic clamp	2
27	550-010 Handle 3	4
28	111-076 Set square (left)	1
29	141-138 Tightening knob	6
31	111-084 Head	1
32	144-007 Y Axis motion shaft	2
33	111-071 Router lower bearing housing	1
34	111-069 Arm	1
35	191-005 6204 Bearing	3



No	STOCK NO / PART NAME	QTY
36	111-080 Upper motor lower cover	1
37	141-079 Gas spring connection rod	1
40	192-008 Clamp end 25x35x40 PP	16
47	111-078 Motor cover	1
48	141-069 Bearing shaft connection sleeve	2
53	141-089 Fixing knob shaft bearing	2
58	111-070 Axis bearing	1
63	141-084 Drill bearing support	1
65	204-001 Diameter 10mm Drill bit	2
66	204-002 Diameter 13mm Drill bit	1
68	112-007 Drill bearing	1
70	111-079 Lower motor front cover	1
71	142-021 Lower rotor shaft	1
81	141-077 Arm connection	1
84	111-066 Column bearing	1
88	194-002 16x675 Motor belt	1
89	142-024 Rotor shaft	1
90	144-008 Motion bearing shaft	2
91	191-004 6203 Bearing 17x40x12	1
95	141-294 Lower motion rod	1
98	141-091 Router bit holder	1
99	273-001 Gas spring 3545 400N	1
100	171-019 M8x30 Hexagonal screw	8
102	141-090 Rod sleeve	1
103	172-030 M8x45 Hexagonal screw	5
104	145-016 Arm connection rod	1
105	550-013 Electric motor	2



3. SAFETY

3.1. SAFETY INFORMATION

5031 63 #00' #0. 0 # 03 B | 00' *130* 6 0# #
 0 *# | 39# / 10 :. B). (3 :. 0 100(*4 0# 403.#6
 *# B

IMPORTANT

50IMPORTANT 31 61 90*3 # 06# . 44830* 6. 0 '# | 0). Q 6
). B# (1030*70 40 * #

CAUTION !

50CAUTION! 31 61 90. #B(. *# 30*1'. #03 '# 0(*03 0
 100 | 39# :. B). (3 :. 0 100(*4 0#



DANGER WARNING

DANGER WARNING .1 90. #B(. *B 30 *' . #03. '# Q*#0B
0(*0310 0 0 1 309#. . B036*#0*(B *B*# B
0 3 0' 10(32. # 4. Q 6 Q 0(3# 10: .) 1*#) . B# (
: . *#0# #0



3.2. PREVENTION OF ACCIDENTS

- 3.2.1 8 : .) 1*#03 0 . #/) (0 *#) . '#0 *1F DD. '#F , ,C HF
3/0B *0 *903 1) 1) 90 #* #6 #*#0 #* #63/0B *0 *903
- 3.2.2 *310. 3G 100 46B0 #*33 // *#) * 0#*36 *#10 #
4090# #/) * 0#3 4 9 0/ # 03 B3/0B0(*4 0# '# 09 03/ 10
40 23/0B
- 3.2.3 0' 03 *# G*1 10 .) 1*# 10 40 3 ('6) 10 G0/0 (03 /
10 .) 1*# 0 # 6 0 *3 / 10 .) 1*# 03 40 * #
- 3.2.4 50: .) 1*# 03 ('6) 0 40 0 # B3 //: 01 03 1 1 90 0' . '#
('#03 ' 10) #0#3 / 1*3. # 6
- 3.2.5 6 *0 *903 0 : : 0# * #B '# 0# 63/0B(03 #*# *#1*3. # 6
1 90 1 01 390 / 6 50 .) 1*# . ## 1 0 40 0 *# #. B/ 4 4 33
10 1 #1 3 0B* 0 100*#810 *3 10. #/) (0 3 6# 1 0 00 0
034 # 0/ . # : . 03 *#*03 '# 3) 1) * (: 3 #03 ('6 0 10
0 *#* #/ 10 . . #B

3.3. GENERAL SAFETY INFORMATION



- 3.3.1 504 0) .1 03 ('6) 00 *#3) 1. B1 # ' B) #304 #
1*#) . #046) 0 # 40* 6. 01 3 i 0. 0#0. ' *# 10*#0. '#
(0 3) 03



3.3.2. /104 0).1 03('6l 0 :. 0' (*# 40 * # # () 1. '#
(#6 * 090(3 :. 0 4 0).1 03

3.3.3. # 906' :.) 1*#03/ ' *6#. '#)(*# (:.) 1*# *6 40 0
: 03/0B *1 4 0 (44B*#)) ' #0 *1 103*4.6 0 9 (603



3.3.4. #246) 0B(1 '#B 0 00#4 3*# * #



3.3.5. 3) 4 0 *90 0B0 .6 303 '# 0 46 3 # 0 9030) 6 103 '#
0 03500). # 0. (11 B 9# 4 3



3.3.6. 004B(*# 46) 0 6 B3 0 # B '#* B/ .)) * 0#4090# #
' # 3/0 40 * #

3.3.7. 3) 0 *6 *#* #/ 10 3/0B / 10 40 & C C50
* 1*# /# 030 3

3.3.8. # 0 90 #1*# #10 .) 1*#

3.3.9. # (3) # 0* 8 10.1 #1 30 :. 0#01 B 10
: . (#/) (07) (*# 40 * # #10 .) 1*#

3.3.10. F # 0 1 10 40 0*3).6 40 . 44 4* 0B B 10. .) 1*#03
) .6 4 9 0



3.3.11. F # 03/0 *# 4 3* # 6 B3 04B(1. .6 #0

3.3.12. 004B(: .) 1*# 6 B3 0 # 3/0 40 * # 6 10*#() * #
: . *#0# #0. '# 046) 0 0# (.)) 03 *03 H0 G0 46 '#). 1 0
0 (.6 B / . :. 0 0 * 046) 0 B (. 80 00) * # 0041 '# 03 #
*43/00 / . # *6 '# 0 3

3.3.13. #6 *3l Q 0) '#) *#. '#. . *#0# #0 3

3.3.14. F # 0 1 # 0B . ' (3 0# 81 90 00# 0 90 1 Q 0
40 *# 10 .) 1*#



3.3.15. /B(. 0 0(*0 40 0 10 .) 1*# (3 0(3 # 44 4* 0
0 0# #.1 63

3.3.16. 04*33('6l 0). *0 (l B (. #0 0 1#* # # 8 10 *3
.)) * 0#3. B)) (

3.3.17. 0 0 3 *#. # 40 * #) 10 G10. 44 4* 0 / #* # /
4 0 * 90 09 03 '#. 30# 01 10B 4 40B 4 '#** #l 90 /
l 0 / #0 *# ' 0 0# 0 4 40 40 * # / B(:) 1*# : 0
4 0 * 90 4 3 '# 0 (* 4 0# 1 90 l 0 046) 0 04 * 0 4 40B l B 10
: . #/) (0 0 0

3.3.18. # (3 .) 1*# 3 * 1* 4 40 / #* ## (# '# 3*) 103

3.3.19. # 04/6 : l 6) : l (3 90 # (* 3 '#. . 0* 3# 10 .) 1*#
. '# 00)) #0 * #

4. TRANSPORT OF THE MACHINE

IMPORTANT

4.1.1. 50. #4 3 ('d 0 # B (. #0 403 #06 #

4.1.2. 50 .) 1*# 3 ('d 0. #4 0 l B #*# * 1 4 40 0 (* 4 0# #) 1*#
10 ('# (*# 10. #4

4.1.3. - .) 1*# 3 0) 900 * 1 #6 #' 090B(#03 10)(3: 0 1 3# 0 (* 0
10: 0 1' / 4) *

4.1.4. 10 0 * 1 ' : 0# # # ' 0 1 #. 6/0 (03 / 10: .) 1*# 46 3 30
4 07

4.1.5. - 9l 04 3 # 10 .) 1*# 3 ('d 0 * 0 l 0 0). B# (10. #4

5. INSTALLATION OF THE MACHINE

5.1. PREPARATION

5.1.1. 50 (0 * 0# # / 10 .) 1*# 0 0# # ('# 0 50 1# 60 (03 #
4 07 50 ('# 100 10 .) 1*# * 6 046) 0 3 ('d 0 090# 3# 0# (1
1 0 10 0 * 1 / 10 .) 1*#

5.1.2. 50 .) 1*# 3 ('d 06. 0. 44 7D . B/ : 100 6504 0
) #0 * #46 / 10 .) 1*# 36. 0 # 10 0 3 0 / 10 .) 1*#



5.1.4. 10) 4B (0: .) 1*#03 D - * 100344 | . 3 *(0 10 .) 0#0 7 3# 101 '#0
 , C* 10/0#00344 + *1*330* 60 , @

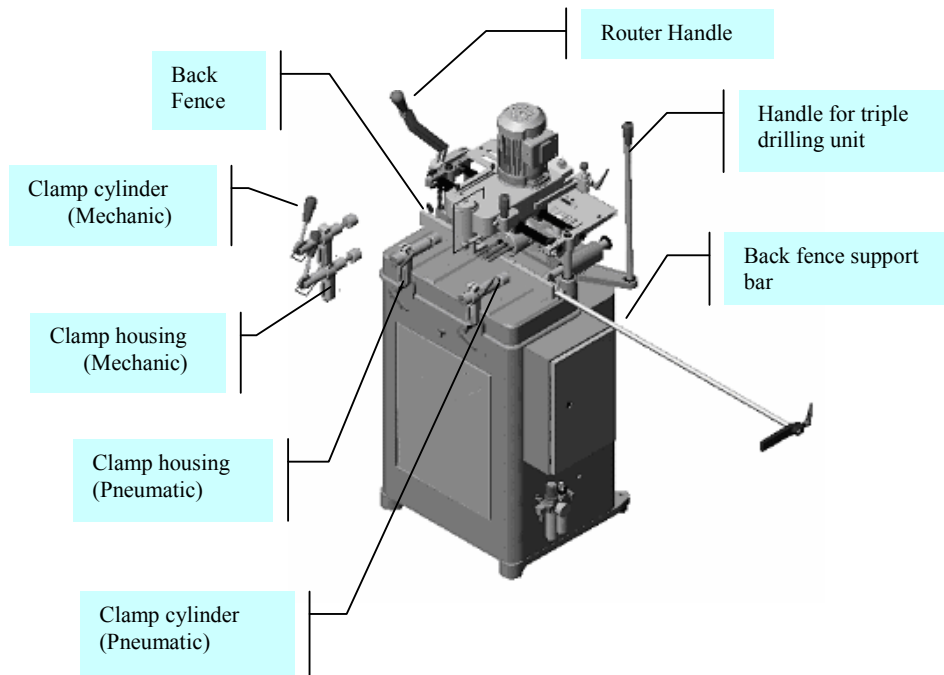

Figure - 4

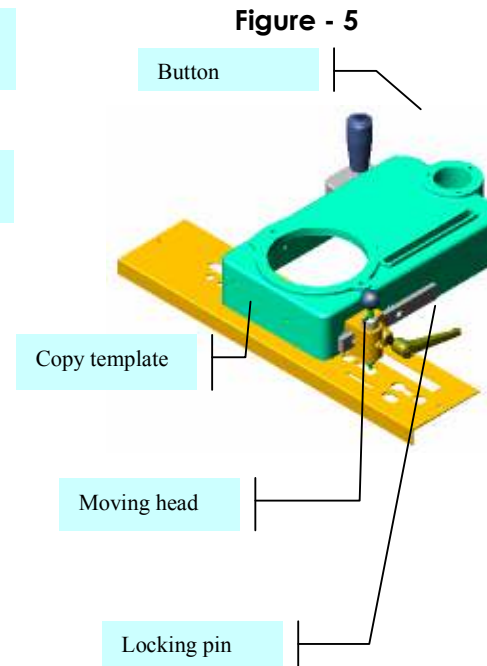

Figure - 5



5.2. ELECTRIC CONNECTION

- 5.2.1 5010041 3000 *) .1 03) G1 3 | 0*#)) ' . #0 *1 103) G #
- 5.2.2 (: ' 08 D 109 6 0) . # 0) 1 3 # 3 +D 7D D D
- 5.2.3 (6 10 .) 1*# . ('# 0 3) G

CAUTION!

- 5.2.4 H0 G0344896 0 503() 09 6 Q (3 0*#)) ' . #0 *1 10
- 5.2.5 5000 *) # * #1 90 | 0) . * 0 (| B (* 0 00) * # # 50
- 5.2.6 / 10 (0 * * # * 0 * # 3 0 9 0 3 *) . (3 3 . # 0 1 / 10 40

NOTE: THIS IS VALID FOR THREE-PHASE MOTORS.

6. MACHINE SAFETY INFORMATION

- 6.1.1 50 .) 1*# 0 3 (' 6 # | Q 3) * 1 (10 . # 4 0 # 4 Q * # 3 * 0 6 * # #
- 6.1.2 * / # * # 6 * # 0 0) * : . * # 0 # # 0 / 10 .) 1*# 0 3 (' 6 | 0) . * 0 (| B
- 6.1.3 (* # : * # 0 # # 0 . ' # 3 1 0 (0 : * # 0 # # 0 3 (' 6 | 0) . * 0 (| B
- 6.1.4 F # 0 1 10 .) 1*# 0 1 B 0 0 # 0 # 0 3 0 . ' # : . * # * # 0 | Q 0 3 * #
- 6.1.5 H0 G03/0B 09 034 0) . 1 0 '# : 9 # 4 3 0 (6 B # 2 4 0 0
- 6.1.6 0 9 0 0 4 6 0 1 0 (0 * ' * # * B 0 / Q # 4 6 * # / * 3
- 6.1.7 0 0 4 / 0 # . 0 * 3 . B / : 10 * # . 0 / 10 .) 1*# 0 0 4 . B

IMPORTANT

503/0B . . 1 9 0 0 0 # 0 * # . 1 9 0 # ' 0 4 0 9 0 # 4 1 B 3 6 : . 0



7. OPERATION

7.1. STARTING TO WORK

- 7.1.1 F# 01 10.) 1*#0.1 0 '#. 6*# /4 3,0 0 #'# B 0 0 0
- 7.1.2 H0 # (3 /) 03 / 10 .) 1*# /:) 1*4 '# / 0 #4 } 03 0000 .6303
- 7.1.3 H0 G*1 10 44 4* 0 031 10 (0 *.'# *6*3 0*10# 06
- 7.1.4 H0 G0 (0 *.'# *6*3' 0 1 0#*#.'# 0 *# 046) 0 10 * /
- 7.1.5 50) 4B (0:) 1*#03 D - 0 0 / 40## / 06) G 403
- 7.1.6 * 10 6 *# H ' 4 /6 # 1 1 B(#) 4B1 03 3 3
- 7.1.7 6) 0 10 4## 10 030 3 40 #10) 4B 0 46 0 00*(07
- 7.1.8 (3 103 30 3 1(# 4 3* #
- 7.1.9 A 40 0 10 (0 1 * 1 B 04# 10 4 3 (# #10 9# 10'
- 7.1.10 101 * # 6*46 *6# 40 * # 1*0 04# 10 (# #101 '#0
- 7.1.11 5010*1 / 10 *461 * # 6 *6#(#. (: ' 06 D -). # 0
- 7.1.12 06 3 10 (# / 0 10) 4B# 40 * #3*#30 50 (0 * 3 43
- 7.1.13 840#10).6 43 '#. G(104) 030 4

NOTE:

*34 3 0 . ' (3 / (' % / 00# 3 * 64 / 6 10 * 13 * 1 10 10 * 1 . ' (3 0 #

' # 040#0#B /: 10) 4B# 0 1 #3 B(). # 40# 1 #03 '# 3 3 /

, D: D #10. *3. +D: 7 #10. *3 # D: +7 #10

. *3

CAUTION!

7.1.14 # 4) 03104 /6 0 0).6 4# 10 40 04 40B



7.1.15 The router bit and triple drill unit should be moved down only after the regular rotation has been reached.

8. CHANGING THE ROUTER BIT AND DRILL BITS

8.1. / * 1 0 : 03 # 03 B 04) 0 10 (01 * / . # 0 3 # / 6 10 / 6 * #
0 / 046) 0 0 #



8.1.1 #6 10 .) 1 * #
8.1.2 * 1 10 . 0 # 1 # 3 . ' # @ 3 # 10 (01 * 1 ' 60 B (## 10 6 /
10 (01 * 1 ' 60 * # (# 0) 6 # 3) * 0 * # 0 90 10 (01 * / : * 31 ' 60
10 # (01 * * # 10 1 ' 60 . ' # * 1 0 # 10 6 * 1 10 0 # 1 # 3

NOTE: Ensure that the router bit is fixed properly.

CAUTION!

8.1.3 Check the router bit before using it. The router bit has to be inserted into the holder properly. Don't use damaged router bits with improper function. Operate the machine for at least 30 seconds to be sure that the router bit has been inserted and fixed correctly.

8.2 CHANGING THE TRIPLE DRILL BITS



8.2.1 #6 10 .) 1 * #
8.2.2 3 # 10 } 0 # 10) # 0 * # / 10 * 40 * 6 # (# 3 * 63 / * 1. † :
10 . # 6 # 046) 0 10 * 6 . ' # * 1 0 # 10 } 0

NOTE: Ensure that the drill bit is tightened properly.



9. ADJUSTING THE AIR PRESSURE OF PNEUMATIC CLAMPS (AT OUR MODELS LIBRA-02 M and LIBRA-02 HM)

- 9.1. (10' (3 0# (# / 10) '#** # (4. ' 3 *
- a 5 ## 10' (3 0# (## 6) * 0 * ## 0 3310403 0
- b 5 ## 10' (3 0# (## (# 0) 6) * 0 * # 0 0 3310403 0
- 9.2 8 # 0 B (0' # 10 # 00 4 3 10.' (3 0# (# / 10) '#** # # '# 6) * # 1 4 3 * #

CAUTION!

The air supply to the machine has to balance 6-8 Bar (90-120 psi) pressure. Don't operate the machine at an air pressure lower than 6 Bar (90 psi).

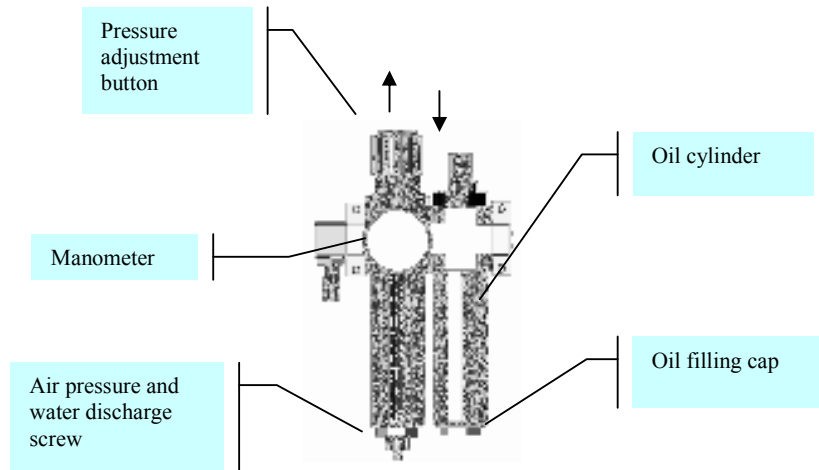

Figure-6

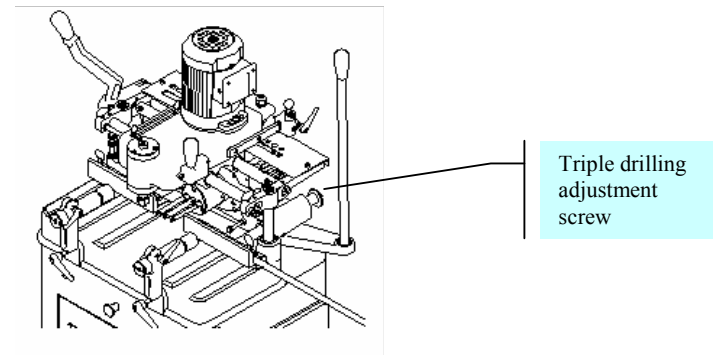

Figure-7



9.3 # ' 0 4090# 1 10 . 0 * # 0 10 . * 330) (33 : 0 10
 4 # : .) 330) : 4 # # 3 10) ' # * # (#) 310 . 0 * # 10) * #
 0 04) 0 * 31 0 10) 0 0 40 * * . 100 # / 10 * # . B
 1 B403 # 10 (# # 0 10 B # 0 04 / 10) ' # * #
 9.4 50 . # /) (0 0 : : 0 # 3 (3 10 / 6 * # * 3 * 1 10) ' # * # 5 A
 H D F F E 8 D 8 5 E 5 F 5 8 8 A A D

10. MAINTENANCE

10.1 PERIODIC CONTROLS AND MAINTENANCE AT THE END OF THE WORKING DAY

10.1.1 # 6 10) 1 * # * 3
 10.1.2 H 0 G 0 * 6 9 0 6 / 10) ' # * # 1 * 1 6 * . 0 3 1 0 4 # : .) 330
 1 0 0 3 * # 4 0 0 1 0 .) 1 * # 5 0 * 6 9 0 6 0 0 3 3 * 1 1 0 * 0 () . #
 0 * 6 * 6 B 4 0 # # 1 0 * (* #) . 4 / 10) B # 0 0 4 : . # 6 * 1 . 0
 10.1.3 H 0 G 0 (a * / * 3 4 4 0 (# * # 0) 1 4 0 * # 0 4) 0 : . . 0
 (a *
 10.1.4 / B (1 9 0 3) . 0 . 0 . 3) 6 (* 3 (* # * # 4 0 * # B 1 0
 : .) 1 * # * 1 . ' B 6 i . / 0 1 0 4 0 * # 3 * # 3 0 / 1 0 .) 1 * # * 6 # 1 0 3
 } . 6 # * 0 6 * . 0 1 0 # * # 0 3 * # / 1 0 .) 1 * # 3 4 0 * # . * #
 3 #
 10.1.5 0 9 0 6 (/ 0 * # . 0 * 3 : . 1 0 .) 1 * # 2 3 / 1 0
 10.1.6 1 0 # 0 # # 1 0 .) 1 * # 2 (3 # . 0 * 3 1 1) (' 6) . (3 : . . 0
 1 0 .) 1 * # 2 4 * #

11. INFORMATION ABOUT FAULTY USE

11.1 H 0 G 0 4 6 / 4 0 3 4 4 B
 11.2 0 0 4 1 0 (# 4 0 3 3 /) # # (3 # # / 1 0 (a *
 11.3 F # 0 1 1 0 . * # * 0 * # / 1 0 (a * . ' # 1 0 * 4 6 * 6 # (# * 3 0
 3 0 1 0 (# # * 0 * # 0 3 # 1 0 .) 1 * #
 11.4 # 3 * 1 0 4 / 6 0 0 1 0 4 # : .) . 6 4 3 1 9 0) . 6 4 0 1 0
 4 / 6 4 4 0 B
 11.5 5 * 3 .) 1 * # * 3 3 / 4 0 # # / 3 3) 1 # 0 3 * # 9 * (3 * 0 # # # H
 . 6 * # 4 / 6 3 ' # ' 0 # . 0 * 3



12. ELECTRIC / PNEUMATIC COMPONENTS

11.1 ELECTRIC COMPONENTS

STOCK CODE	PART NAME	QTY
161-006	MAIN SWITCH KG10B	1
162-003	CAPACITOR 25 MF 250 V	1
162-004	CONTACTOR LC1 K 0610 M7	1
163-004	SINGLE-PHASE WIRING	1
163-006	ROTOR STATOR	1
164-002	0.75 mm CABLE (BLACK)	0.5
164-006	1.5 mm CABLE (BLACK)	1.5
164-011	3*1.5 TTR CABLE	3
164-014	INTERM. CABLE 2*1 TTR	0.65
164-022	7*0.75 mm CONTROL CABLE	0.145
164-024	6*1 CONTROL CABLE	1.45
165-009	PUSH BUTTON D22-TS	1
165-011	PERFORATED RAIL (KLEMSAN)	0.15
165-012	WGD1 CONNECTOR STOPPER	2
165-016	CABLE CHANNEL (37.5*37.5)	0.4
165-020	PEK 2.5 MM. BEIGE CONNECTOR	5
165-021	NO:1 ROW CONNECTOR	0.07
165-025	PEK 2.5 mm BLUE CONNECTOR	1
165-028	TERMINAL SHEET NPP 2.5 10	3
165-029	PG 11 SLEEVE	1
165-031	PG 13.5	1
165-033	PG 16	3
165-040	WARNING LABEL IP 2S	2
165-048	GROUNDING CONNECTOR WGT4	2

11.2. PNEUMATIC COMPONENTS

STOCK CODE	PART NAME	QTY
241-004	6mm AIR HOSE	2.2
241-005	AIR GUN HOSE	2.5
241-009	FRC-1/8-D-MINI/CONDITIONER	1
241-022	1/4 EXHAUST (SC-SINTER)	1
241-023	SV 1/4-3/2 D.O MANUAL VALVE	1
242-001	AIR GUN LBP-1/4	1
243-004	1/4 HOSE INLET	1
243-008	1/4 TRIPLE DISTRIBUTOR	1
243-009	LATERAL QUADR. T S6440-6-1/4	1
243-010	1/4-1/8 NIPPLE (DECREASING)	1
243-011	1/4-6 SLEEVE (S6510-6-1/4)	1
243-014	1/4-8 SLEEVE (S6510-8-1/4)	1
243-023	1/8-6 ANKLE (S6520-6-1/8)	2
243-025	1/8-6 SLEEVE (S6510-6-1/8)	1
244-011	O RING 28*2	2



12. TROUBLESHOOTING

00 03 00 :: 0# * #/ 30#(0#41 0 3/10 (1 0). ##1 0
 300 *B(1 90 41 0 10 1 #1 3 0B* 0 100 '#0 40 3) #)
 (0 1 #. 60 9 0 B(# 03 0 0

TROUBLE	CAUSES	REMEDY
β/) 0 (. 6B : 6 *# : # 3 % : 0 * β (1 β /) 0 . 0 1 * 4 β /) 0 0 # 3	β /) 03 0 1 β # (0 1 * (3)	(1 .) 0 1 0 β /) 03 / 10 (0 * 3) /) 6 # 6 (* H0 G0 * 4 / 10 (0 * '# * 3) (* # / 6 03 10 * 4 (' 0 0 # / 3 0 4) 0 1 0 (0 *
- 03# G i (1 1 03 (# # 1 0 6 9 0 * 3 0 4 0 3)	500 * 3 # 4 0 β 4 4 B 10 .) 1 * #	H0 G0 0 0 *) # 0 * # H0 G0 4 0 3) 0 3
- (# (1 0 4 # : *) 6 4 4 3 # # G	50 * β 4 4 B # 0 * # . 0 * 3 # / (B	H0 G0 *) (3 10 * 4 0 3 0) # * #
50 (0 * . 03 # 0 9 0 3 * 0 * #	50 0 0 *) # 0 * # 4 0 . 1 0) # 6 4 # 6 # 0 * # 3 #	0 1 0 0 0 *) # 0 * #. B (1 B (. 0 0 0) * #

Free Manuals Download Website

<http://myh66.com>

<http://usermanuals.us>

<http://www.somanuals.com>

<http://www.4manuals.cc>

<http://www.manual-lib.com>

<http://www.404manual.com>

<http://www.luxmanual.com>

<http://aubethermostatmanual.com>

Golf course search by state

<http://golfingnear.com>

Email search by domain

<http://emailbydomain.com>

Auto manuals search

<http://auto.somanuals.com>

TV manuals search

<http://tv.somanuals.com>