

CHICAGO
Electric[®]Power Tools

RADIAL ARM SAW
8-1/4"

Model 42933

SET UP AND OPERATING INSTRUCTIONS

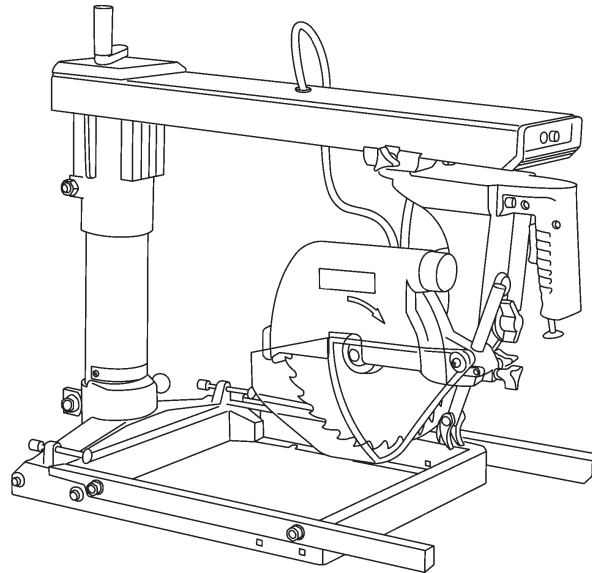

Distributed exclusively by Harbor Freight Tools[®].
3491 Mission Oaks Blvd., Camarillo, CA 93011
Visit our website at: <http://www.harborfreight.com>



Read this material before using this product.
Failure to do so can result in serious injury.
SAVE THIS MANUAL.

Copyright[®] 2000 by Harbor Freight Tools[®]. All rights reserved. No portion of this manual or any artwork contained herein may be reproduced in any shape or form without the express written consent of Harbor Freight Tools. Diagrams within this manual may not be drawn proportionally. Due to continuing improvements, actual product may differ slightly from the product described herein. Tools required for assembly and service may not be included.

For technical questions or replacement parts, please call 1-800-444-3353.

REV 04k; 06I; manual revised 09d

CONTENTS	
IMPORTANT SAFETY INFORMATION	3
GENERAL TOOL SAFETY WARNINGS.....	3
GROUNDING INSTRUCTIONS	5
110-120 V~ GROUNDED TOOLS: TOOLS WITH THREE PRONG PLUGS	5
RADIAL ARM SAW SAFETY WARNINGS.....	5
ESSENTIAL STRAIGHT PUSH-STICK FEATURES AND FUNCTIONS	7
SPECIFICATIONS.....	10
UNPACKING	10
INSTALLATION.....	10
OPERATING CONTROLS	12
ADJUSTMENTS.....	14
CUTTING KERF MARKS.....	15
OPERATION	16
CROSS CUTTING	16
MITRE CROSS CUTTING	16
BEVEL CROSS CUTTING	17
COMPOUND CROSS CUTTING.....	17
IN-RIP CUTTING	17
OUT-RIP CUTTING.....	18
MAINTENANCE	19
TROUBLESHOOTING.....	20
PARTS LIST	21
ASSEMBLY DIAGRAM (1-97)	22
ASSEMBLY DIAGRAM (98-167)	23
LIMITED 90 DAY WARRANTY ...	24

SAVE THIS MANUAL

Keep this manual for the safety warnings and precautions, assembly, operating, inspection, maintenance and cleaning procedures. Write the product's serial number in the back of the manual near the assembly diagram (or month and year of purchase if product has no number). Keep this manual and the receipt in a safe and dry place for future reference.

IMPORTANT SAFETY INFORMATION

In this manual, on the labeling, and all other information provided with this product:



This is the safety alert symbol. It is used to alert you to potential personal injury hazards. Obey all safety messages that follow this symbol to avoid possible injury or death.

DANGER

DANGER indicates a hazardous situation which, if not avoided, will result in death or serious injury.

WARNING

WARNING indicates a hazardous situation which, if not avoided, could result in death or serious injury.

CAUTION

CAUTION, used with the safety alert symbol, indicates a hazardous situation which, if not avoided, could result in minor or moderate injury.

NOTICE

NOTICE is used to address practices not related to personal injury.

CAUTION

CAUTION, without the safety alert symbol, is used to address practices not related to personal injury.

General Tool Safety Warnings



WARNING Read all safety warnings and instructions. *Failure to follow the warnings and instructions may result in electric shock, fire and/or serious injury.* **Save all warnings and instructions for future reference.**

1. KEEP GUARDS IN PLACE and in working order.
2. REMOVE ADJUSTING KEYS AND WRENCHES. Form habit of checking to see that keys and adjusting wrenches are removed from tool before turning it on.
3. KEEP WORK AREA CLEAN. Cluttered areas and benches invite accidents.
4. DON'T USE IN DANGEROUS ENVIRONMENT. Don't use power tools in damp or wet locations, or expose them to rain. Keep work area well lighted.
5. KEEP CHILDREN AWAY. All visitors should be kept safe distance from work area.
6. MAKE WORKSHOP KID PROOF with padlocks, master switches, or by removing starter keys.
7. DON'T FORCE TOOL. It will do the job better and safer at the rate for which it was designed.

8. USE RIGHT TOOL. Don't force tool or attachment to do a job for which it was not designed.

RECOMMENDED MINIMUM WIRE GAUGE FOR EXTENSION CORDS (120 VOLT)				
NAMEPLATE AMPERES (at full load)	EXTENSION CORD LENGTH			
	25'	50'	100'	150'
0 – 6	18	16	16	14
6.1 – 10	18	16	14	12
10.1 – 12	16	16	14	12
12.1 – 16	14	12	Do not use.	

TABLE A

9. USE PROPER EXTENSION CORD. Make sure your extension cord is in good condition. When using an extension cord, be sure to use one heavy enough to carry the current your product will draw. An undersized cord will cause a drop in line voltage resulting in loss of power and overheating. Table A shows the correct size to use depending on cord length and nameplate ampere rating. If in doubt, use the next heavier gauge. The smaller the gauge number, the heavier the cord.
10. WEAR PROPER APPAREL. Do not wear loose clothing, gloves, neckties, rings, bracelets, or other jewelry which may get caught in moving parts. Nonslip footwear is recommended. Wear protective hair covering to contain long hair.
11. ALWAYS USE SAFETY GLASSES. Also use face or dust mask if cutting operation is dusty. Everyday eyeglasses only have impact resistant lenses, they are NOT safety glasses.
12. SECURE WORK. Use clamps or a vise to hold work when practical. It's

safer than using your hand and it frees both hands to operate tool.

13. DON'T OVERREACH. Keep proper footing and balance at all times.
14. MAINTAIN TOOLS WITH CARE. Keep tools sharp and clean for best and safest performance. Follow instructions for lubricating and changing accessories.
15. DISCONNECT TOOLS before servicing; when changing accessories, such as blades, bits, cutters, and the like.
16. REDUCE THE RISK OF UNINTENTIONAL STARTING. Make sure switch is in off position before plugging in.
17. USE RECOMMENDED ACCESSORIES. Consult the owner's manual for recommended accessories. The use of improper accessories may cause risk of injury to persons.
18. NEVER STAND ON TOOL. Serious injury could occur if the tool is tipped or if the cutting tool is unintentionally contacted.
19. CHECK DAMAGED PARTS. Before further use of the tool, a guard or other part that is damaged should be carefully checked to determine that it will operate properly and perform its intended function – check for alignment of moving parts, binding of moving parts, breakage of parts, mounting, and any other conditions that may affect its operation. A guard or other part that is damaged should be properly repaired or replaced.
20. DIRECTION OF FEED. Feed work into a blade or cutter against the direction of rotation of the blade or cutter only.

21. NEVER LEAVE TOOL RUNNING UNATTENDED. TURN POWER OFF. Don't leave tool until it comes to a complete stop.

GROUNDING INSTRUCTIONS

⚠ WARNING TO PREVENT ELECTRIC SHOCK



AND DEATH FROM INCORRECT GROUNDING WIRE CONNECTION READ AND FOLLOW THESE INSTRUCTIONS:

110-120 V~ Grounded Tools: Tools with Three Prong Plugs

1. In the event of a malfunction or breakdown, grounding provides a path of least resistance for electric current to reduce the risk of electric shock. This tool is equipped with an electric cord having an equipment-grounding conductor and a grounding plug. The plug must be plugged into a matching outlet that is properly installed and grounded in accordance with all local codes and ordinances.
2. Do not modify the plug provided – if it will not fit the outlet, have the proper outlet installed by a qualified electrician.
3. Improper connection of the equipment-grounding conductor can result in a risk of electric shock. The conductor with insulation having an outer surface that is green with or without yellow stripes is the equipment-grounding conductor. If repair or replacement of the electric cord or plug is necessary, do not connect the equipment-grounding conductor to a live terminal.

4. Check with a qualified electrician or service personnel if the grounding instructions are not completely understood, or if in doubt as to whether the tool is properly grounded.
5. Use only 3-wire extension cords that have 3-prong grounding plugs and 3-pole receptacles that accept the tool's plug.
6. Repair or replace damaged or worn cord immediately.

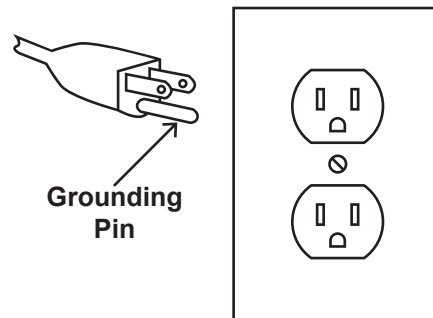

125 V~ 3-Prong Plug and Outlet (for up to 125 V~ and up to 15 A)

7. This tool is intended for use on a circuit that has an outlet that looks like the one illustrated above in **125 V~ 3-Prong Plug and Outlet**. The tool has a grounding plug that looks like the plug illustrated above in **125 V~ 3-Prong Plug and Outlet**.
8. The outlet must be properly installed and grounded in accordance with all codes and ordinances.
9. Do not use an adapter to connect this tool to a different outlet.

Radial Arm Saw Safety Warnings

For Your Own Safety Read Instruction Manual Before Operating Saw

1. **DANGER! Coasting Cutting Tool Can Be Dangerous – Apply brake immediately to stop cutting tool when the switch is turned off.**

2. **The torque developed during braking may loosen the blade-retaining nut/bolt.** The blade retaining nut/ bolt should be checked periodically and tightened if necessary, especially after braking.
 3. Wear eye protection.
 4. Keep hands out of path of saw blade.
 5. Know how to reduce risk of kickback.
 6. Use an appropriate push-stick for narrow work.
 7. Do not perform any operation free-hand.
 8. Never reach around saw blade.
 9. Return carriage to the full rear position after each crosscut operation.
 10. Turn off tool and wait for saw blade to stop before moving workpiece or changing settings.
 11. Disconnect power before changing blade or servicing.
 12. To properly understand all safety warnings, be familiar with the following safety terms and equipment:
 - a. Through-sawing – A cut made from one side of a board to the opposite side, without stopping.
 - b. Ripcut or Ripping - A cut made parallel to (along with) the grain of the wood.
 - c. Crosscut or Crosscutting - A cut made perpendicular (at a 90° angle) to the grain of the wood.
 - d. Push-stick – A narrow strip of wood or other soft material with a notch cut into one end and which is used to push short pieces of material through saws. It provides a safe distance between the hands and the cutting tool. Must be narrower than the cut width to prevent contact with the blade.
 - e. Freehand – Feeding a workpiece through the saw without using a fence or guided support to guide it. **NOT A SAFE METHOD.**
 - f. Kerf – The gap made by the saw in the workpiece.
 - g. Kickback – A sudden reaction to a pinched, bound, or misaligned blade, causing an uncontrolled workpiece to lift up and out of the saw toward the operator.
 - h. Spreader – A metal plate that follows the saw blade to keep the kerf (gap) from closing on the saw blade. Spreaders, except riving knives, must be aligned to the blade after blade adjustment to prevent binding.
13. Construct a Push Stick out of Wood according to the guidelines on the following page.

Essential Straight Push-stick Features and Functions

Note: Straight style (traditional) stick shown. A different stick design may be used if it properly protects against all hazards.

Diagram not to scale.

- Push sticks must be made from sturdy, defect-free, plywood or normal wood to prevent unexpected breakage. Material must be at least 1/4" thick, but no thicker than the finished wood.
- Inspect push stick before use and do not use a damaged or deteriorated push stick.
- Push stick dimensions will vary depending on the application and user.

Handle Notch

- Must be far enough down the stick to allow a comfortable and firm grip.
- Must be deep enough to prevent hand from slipping down the stick.
- Do not cut more than halfway into the stick to prevent weakening.
- Corners may be rounded to increase comfort.

Stick Length

- Must be long enough to prevent accidental blade contact.
- At least 6" from end of handle to closest part of notch.

Notch

- Must be right angle cut 30°-40° from the angle of the stick to keep hands out of the line of the blade.
- The lower lip of the notch must be no longer than the workpiece is thick.

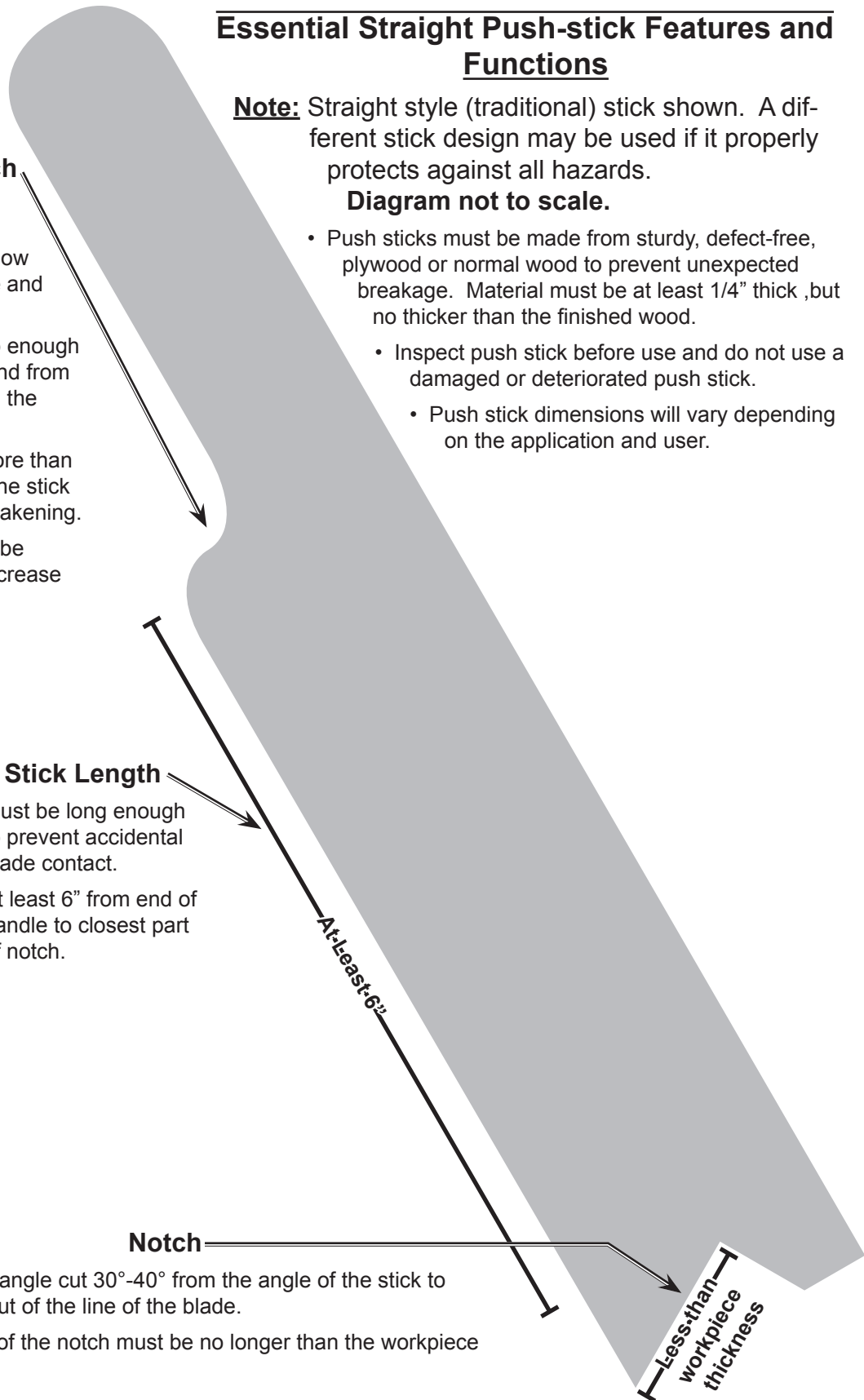

14. Always use the anti-kickback finger attachment when making rip cuts. Feed stock from the opposite end from the anti-kickback finger attachment.
15. Only use 8 1/4" saw blades with 5/8" arbor on this machine.
16. Before making any adjustments to the Radial Arm Saw, the Switch should be in the OFF position and the Switch locked OFF.
17. Lock the carriage arm in place before lowering the saw blade. Otherwise, when the saw blade touches the stock, it may draw itself backward (with you) into the cutting area.
18. Do not cut more than one piece of stock at a time, for any type of cut.
19. When cross cutting, return the carriage arm to the rear position before letting go of the Handle.
20. Do not use abrasive, cut off, or wire wheels.
21. **DO NOT OPERATE WITH ANY GUARD DISABLED, DAMAGED, OR REMOVED. Moving guards must move freely and close instantly.**
22. The use of accessories or attachments not recommended by the manufacturer may result in a risk of injury to persons.
23. When servicing use only identical replacement parts.
24. Only use safety equipment that has been approved by an appropriate standards agency. Unapproved safety equipment may not provide adequate protection. Eye protection must be ANSI-approved and breathing protection must be NIOSH-approved for the specific hazards in the work area.
25. Industrial applications must follow OSHA guidelines.
26. Maintain labels and nameplates on the tool. These carry important safety information. If unreadable or missing, contact Harbor Freight Tools for a replacement.
27. Avoid unintentional starting. Prepare to begin work before turning on the tool.
28. People with pacemakers should consult their physician(s) before use. Electromagnetic fields in close proximity to heart pacemaker could cause pacemaker interference or pacemaker failure.
29. **WARNING:** Some dust created by power sanding, sawing, grinding, drilling, and other construction activities, contains chemicals known [to the State of California] to cause cancer, birth defects or other reproductive harm. Some examples of these chemicals are:
 - Lead from lead-based paints
 - Crystalline silica from bricks and cement or other masonry products
 - Arsenic and chromium from chemically treated lumber
 Your risk from these exposures varies, depending on how often you do this type of work. To reduce your exposure to these chemicals: work in a well ventilated area, and work with approved safety equipment, such as those dust masks that are specially designed to filter out microscopic particles. (California Health & Safety Code § 25249.5, *et seq.*)
30. **WARNING:** Handling the cord on this product will expose you to lead,

a chemical known to the State of California to cause cancer, and birth defects or other reproductive harm. Wash hands after handling. (California Health & Safety Code § 25249.5, *et seq.*)

31. The warnings, precautions, and instructions discussed in this instruction manual cannot cover all possible conditions and situations that may occur. It must be understood by the operator that common sense and caution are factors which cannot be built into this product, but must be supplied by the operator.

3. Wear suitable gloves to reduce the vibration effects on the user.
4. Use tools with the lowest vibration when there is a choice between different processes.
5. Include vibration-free periods each day of work.
6. Grip tool as lightly as possible (while still keeping safe control of it). Let the tool do the work.
7. To reduce vibration, maintain the tool as explained in this manual. If any abnormal vibration occurs, stop use immediately.

Vibration Safety

This tool vibrates during use. Repeated or long-term exposure to vibration may cause temporary or permanent physical injury, particularly to the hands, arms and shoulders. To reduce the risk of vibration-related injury:

1. Anyone using vibrating tools regularly or for an extended period should first be examined by a doctor and then have regular medical check-ups to ensure medical problems are not being caused or worsened from use. Pregnant women or people who have impaired blood circulation to the hand, past hand injuries, nervous system disorders, diabetes, or Raynaud's Disease should not use this tool. If you feel any medical or physical symptoms related to vibration (such as tingling, numbness, and white or blue fingers), seek medical advice as soon as possible.
2. Do not smoke during use. Nicotine reduces the blood supply to the hands and fingers, increasing the risk of vibration-related injury.



**SAVE THESE
INSTRUCTIONS.**

SPECIFICATIONS

Power Requirements	120 V~, 60 Hz, 1-ph 20.9 A (start); 6.9 A (load); 1330 W
Motor	1-3/4 HP, 4200 spindle RPM, electric brake
Saw Blade	8-1/4" (dia.)
Arbor	5/8"
Crosscut Distance	11" (maximum)
Rip Cut Distance	20" (maximum)
Depth of Cuts	45°: 2"; 90°: 2-1/8"
Bevel Index Stops	0, 45, 90°
Mitre Index Stops	Left and right: 0, 15, 30, 45, and 60°
Table Size	15-1/16 x 27-5/8 x 3/4"
Accessories	Blade Replacement: Item # 43204

Note: Performance of this tool may vary depending on variations in local line voltage. Extension cord usage may also affect tool performance.

UNPACKING

When unpacking, check to make sure that all the parts are included. Refer to the Parts List and Assembly Drawing at the end of this manual. If any parts are missing or broken, please call Harbor Freight Tools at 1-800-444-3353 as soon as possible.

INSTALLATION

During the assembly and installation procedure, you may have to refer to the Parts List and Assembly Drawings located at the end of this manual.

1. Secure the Radial Arm Saw to a solid bench top (or table) by bolting (or clamping) the saw frame down to the bench top.
 - The workbench must not be able to slide or tip over. Affix to floor if necessary.
 - Position the Radial Arm Saw (or saw and bench) to slope slightly to the rear so the radial arm carriage will not roll forward due to gravity.

- The workbench should be of the appropriate length and width to allow the operator to stand aside of the saw blade, whatever position the saw blade is in.
- The work area should have adequate, overhead, non-glare lighting.
- Lock the radial arm carriage before moving the unit.

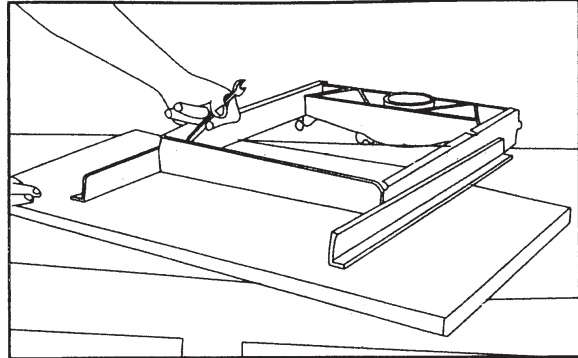

2. Turn the Base (152) assembly upside down. Attach Table A (127) squarely to the Base assembly using the four cross-head Tapping Screws (165).
3. Attach the table stabilizer Stands to both sides of the Base using four Hex Nuts (82), Washers (149), and Round Head Bolts (148).
4. Place the Table and Base assembly on the workbench, right side up. Secure to the workbench with nuts, bolts, and washers (not supplied).

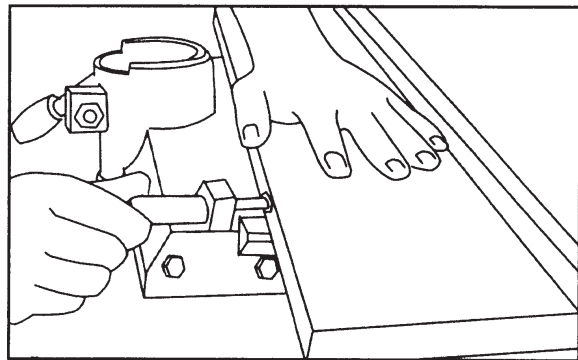

5. Position Table B (126) and Table C (125), and the rip fence (guide) and

secure them by partially tightening the two screw clamps built into the Base assembly.

- Set the Arm (118) assembly column into the Column Base. Move the Arm slightly to the left or right until the column index knob locks into the arm support column. The arm support column has nine positive stops: 0, 15, 30, 45, and 60° (left and right).

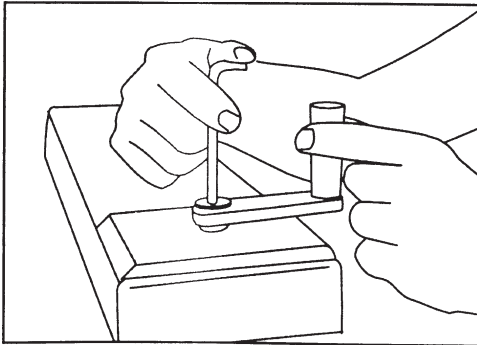

- Attach the Elevating Handle assembly to the Arm using the Allen wrench (provided).

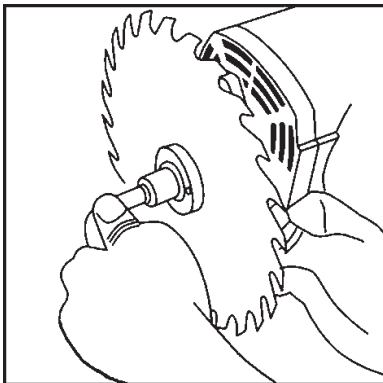

- Attach the Saw Blade (17) to the Gear Shaft (19) and secure with the Outside Flange (16) and Bolt (15). Lock the Gear Shaft with the Stopper Pin (22) located at the front part of the Gear Case Cover (26). Using a wrench, tighten the Bolt (15) over the Outside Flange (16), counterclockwise.

- Place the Safety Guard (10) over the Saw Blade and tighten in place.

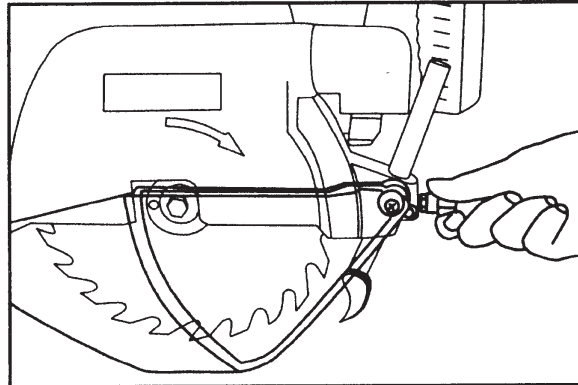

- Install the anti-kickback pawl on the Safety Guard (10) with the pawls facing the rear of the machine.

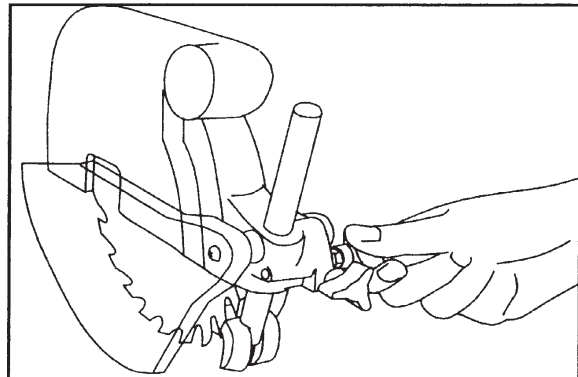

- Set the height by loosening its lock knob and moving it up or down. Retighten again when set to the proper height.
- Verify that no play exists in the carriage, and that the arm, yoke, and bevel locks and clamps are tight.

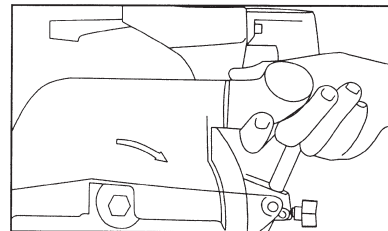

- Slip the Dust Guide (4) over the exhaust stem located on the Safety Guard.

OPERATING CONTROLS

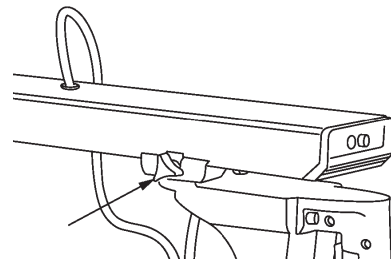
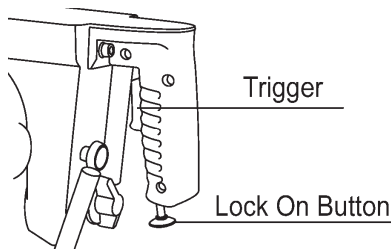
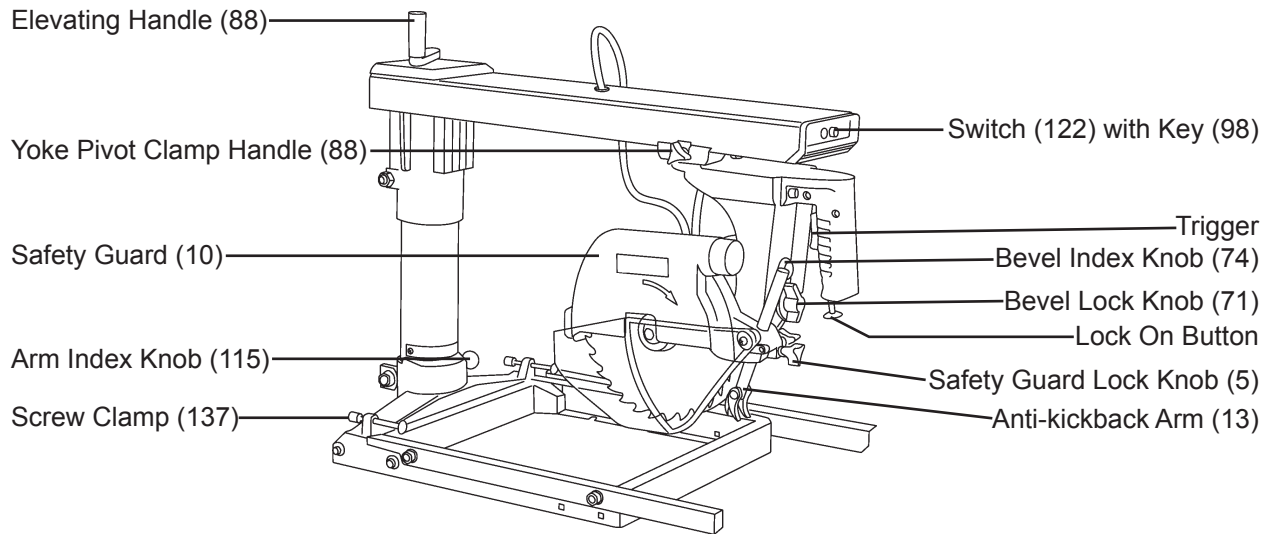

ON / OFF Switch – The Switch has a built-in locking feature which requires a key to be inserted before the saw can be turned ON. Removing the Key and pushing the OFF button locks the saw against unintended use. For crosscutting, press the green Switch in, then squeeze and hold the Trigger. For rip cutting, press the green Switch in, squeeze the Trigger (motor starts), then push up on the Lock On Button (*for rip cutting only*) to keep the motor running without holding the Trigger in. Depressing the Trigger again will release the Lock On Button, turning the motor off.

Carriage Lock – The Carriage Lock Knob located on the left side of the Radial Arm, permits the saw assembly to be moved in or out, and locked at the desired position on the arm. It must be fully released for any crosscutting, and tightly locked for all operations in which the saw assembly is stationary. To lock turn clockwise. To unlock turn counterclockwise.

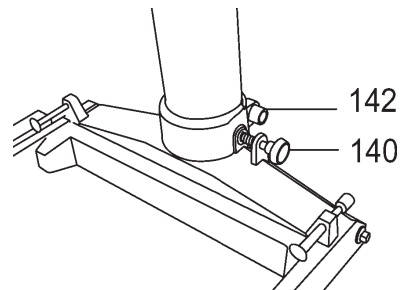

Arm Angle – The Arm Index Knob (142) and Washer (140) are located at the Column Base (132). They can index, release,

and secure the arm angle for various miter positions. Positive index stops are 0, 15, 30, 45, and 60° (left and right). Non-index stops can also be set within the range of the arm assembly.

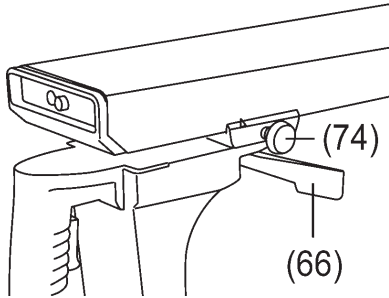

Yoke Pivot- The Yoke Index Knob, located at the top of the Yoke (under the Carriage Arm) indexes the Yoke horizontally to 0° (crosscuts) or 90° (for rip cuts). Loosen the Yoke Pivot Clamp Handle and pull out the Yoke Index Knob. Turn the motor assembly until it locks at the index position. Lock the Yoke Pivot Clamp Handle.

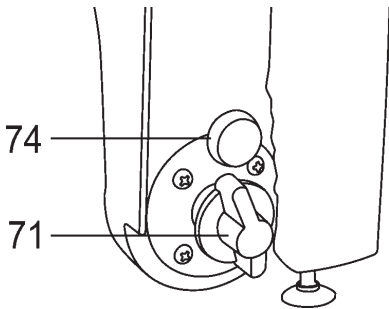

Blade Angle – The Bevel Index Knob (74) and the Bevel Lock Knob (71) are used to set the Blade angle (variable or indexed). Loosen the Bevel Index Knob (71). Turn the motor assembly clockwise or counterclockwise to the index notch of 0, 45, or 90°, or to a variable position without using the index notch. Tighten the Bevel Lock Knob by turning clockwise.

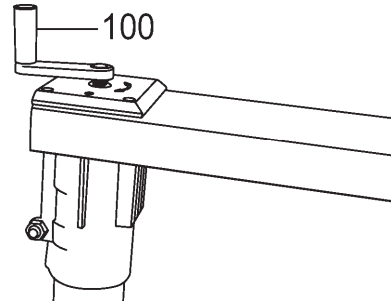

Depth of Cut – The Elevating Handle (100) at the rear of the arm is used to raise and lower the height of the Saw Blade. Turn the Elevating Handle clockwise to raise the Saw Blade or counterclockwise to lower it.

ADJUSTMENTS

The following checks, and possible adjustments, should be done in the order listed before beginning operation.

WARNING: For safety, unplug the line cord to the Radial Arm Saw.

1. Tables A (127), B (126), and C (125) are checked for straightness at the factory.
However, changes in humidity can slightly alter the condition of the wood. With the Screw Clamps (131) tightened, use a straight edge or framing square to check for flatness and squareness. Sand down any high spots using fine sandpaper.
2. Check for Arm tightness on the Column (132). If loose, tighten Bolt (115).

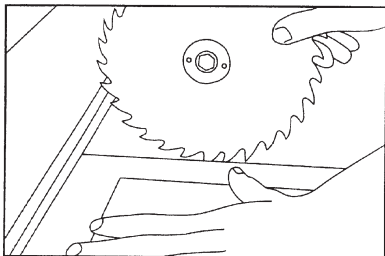

3. Check the crosscut travel of the Saw Blade for squareness.
 - Lock or tighten all adjustment levers and knobs.
 - Lower the Arm until it just clears the Table A front.
 - Place a framing square so it just touches a tooth of the Saw Blade.
 - Mark this location with a pencil on the table and draw a straight line using the square.
 - Check that the Saw blade follows this line from front to back.If the Saw Blade moves to the right or left side of the line as it travels the entire length of the Arm, loosen the Screw Clamps (137) and lightly tap on the Table left or right side until

there is full travel alignment. Tighten the Screw Clamps again.

4. Check that the Saw Blade is square to Table A.
 - Place a framing square on Table A so that the square is flat on the Saw Blade (not touching teeth).
 - If there is no gap between the square and the Saw Blade, no adjustment is necessary.
 - If the square does not touch the Saw Blade evenly (with the square flat on the Table A), loosen the Bevel Lock Knob (71) and adjust the motor until the gap between Saw Blade and the square is eliminated.
5. Check that the Saw Blade is square to the rip fence.
 - Firmly place a framing square against the rip fence and the blade as shown to the right. The square should not touch any teeth.
 - If the square is not flush with the entire blade, loosen the yoke pivot Clamp Handle (66) and move the motor assembly until any gaps have been eliminated. Tighten the Yoke Pivot Clamp and recheck alignment. (This will simultaneously set both yoke indexing positions for in and out ripping.)

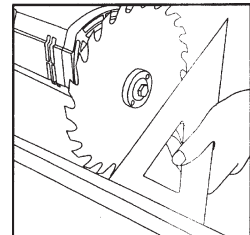
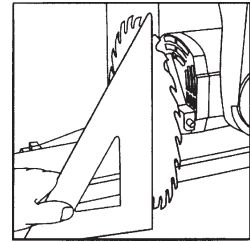

CUTTING KERF MARKS

In order to move the Saw Blade into different cutting positions, kerf marks (or grooves) must be cut into the worktable. It is recommended to cut grooves into a piece of 1/4" plywood mounted to the surface of Table A.

1. Cut a piece of 1/4" plywood the same size as Table A.
2. Mount the plywood to Table A using self-tapping, countersinking screws at the four corners of Table A.
3. Set the Carriage Arm at 0° and lock in place.
4. Set the Saw Blade angle to 0° index position (perpendicular to the worktable).
5. Draw out the Saw Blade to mid-range on the Carriage Arm and lock in that position.
6. Turn the Elevating Handle to lower the Saw Blade so it just touches the plywood top.
7. Place your hand on the Handle Assembly (87) and press the green ON button with the other hand. Squeeze the Trigger (86) to start the motor.
8. With the same hand that you turned ON the machine, loosen the Carriage Lock Knob and slowly move the Saw Blade back, cutting the rip fence; and then move it all the way forward, cutting a groove into the entire depth of the plywood.
9. With the machine still running, turn the Elevating Handle 1/4 turn, lowering the Saw Blade a little more. Pull the Handle back and forth again to cut the plywood groove a little deeper. Tighten the Carriage Lock Knob again.
10. With the machine still running, loosen the yoke Clamp Handle (66) and pull out the Yoke Index Knob and turn the yoke clockwise until it locks into the 90°. This cuts a swing line into the worktable for in-ripping.
11. Once the quarter turn (swing line cut) is complete, lock the yoke Clamp Handle. With the Saw Blade still turning, push on the Handle until the Saw Blade reaches the rip fence, cutting the rip trough in the center of the worktable.
12. Turn the machine OFF and return the Saw Blade to the crosscut position. Lock the Carriage Lock Knob.
13. Turn the machine ON and rotate the Yoke counterclockwise to the out-rip position. This cuts the swing line for out-ripping. Loosen the Carriage Lock Knob.
14. Lock the yoke Clamp Handle (66) and, with the Saw Blade revolving, push the Handle back until the new groove matches the groove cut in step 11. Turn the machine OFF.
15. Return the Saw Blade to the crosscut position. Unlock the Carriage Lock Knob (74b) and move the motor assembly to the rear position, behind the fence. Pull out the Bevel Index Knob (74) and lock the Saw Blade at index position 60°. Turn on machine and pull the Handle forward. This will cut a kerf mark for bevel crosscuts. Turn the machine OFF.
16. Lock the Carriage Lock Knob and start the motor. Pull the Carriage Arm Index Lock Knob and move the Arm to the 45° right-hand miter position. This will cut a groove for miter cuts. Turn the machine OFF.

OPERATION

WARNING: The Radial Arm Saw can be very dangerous and cause serious injuries if not operated properly. Review all safety precautions before operating. Keep hands out of the path of the moving Saw Blade.

Cross Cutting

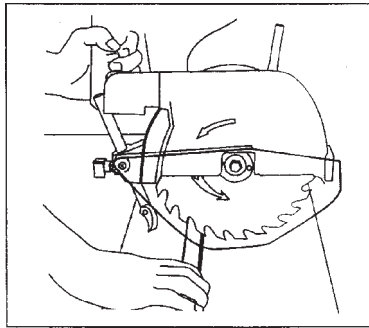

1. Secure the stock to be cut against the table and fence. If the stock length is short, do not hold with your hand. Use a clamp to hold in place.
2. Adjust the Anti-kickback Arm (13) so it just clears the stock.
3. Check that the Pivot Yoke Clamp Lock and Bevel Index Knob are set to 0° and are secure in place.
4. Adjust the Elevating Handle (100) so the Saw Blade (17) height is only 1/8" into the worktable.
5. Push the Handle backward so that the Saw Blade is in behind the stock to be cut.
6. Press the green Switch (122). Squeeze the Handle Trigger and slowly pull the Handle toward you, causing the Saw Blade to cut the stock.
7. When the cut is complete, release the Trigger and push the Handle all the way back.

8. Wait for the Saw Blade to stop turning before removing the stock.

Mitre Cross Cutting

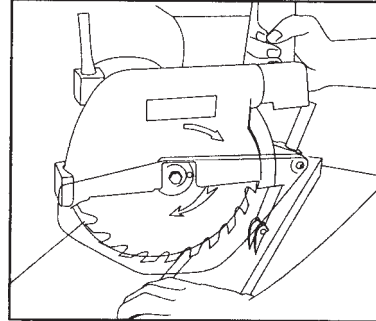

1. Loosen the yoke Clamp Handle (66) and pull out the Yoke Index Knob.
2. Turn the motor assembly to the left or right and lock the Yoke Index Knob at 45°.
3. Tighten the yoke Clamp Handle (66).
4. Push the Handle backward so that the Saw Blade is in behind the stock to be cut.
5. Secure the stock to be cut against the table and fence. If the stock length is short, do not hold with your hand. Use a clamp to hold in place.
6. Adjust the Anti-kickback Arm (13) so it just clears the stock.
7. Press the green Switch (122). Depress and hold the Trigger in. Slowly pull the Handle toward you, causing the Saw Blade to cut the stock.
8. When the cut is complete, release the Trigger and push the Handle all the way back.
9. Wait for the Saw Blade to stop turning before removing the stock.

Bevel Cross Cutting

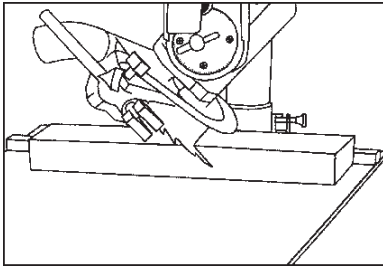

1. Loosen the Bevel Lock Knob (71) and pull out the Bevel Index Knob (74).
2. Turn the motor assembly clockwise or counterclockwise, selecting the desired angle (variable or indexed, i.e., 45°).
3. Tighten the Bevel Lock Knob (71) and push in the Bevel Index Knob (74).
4. Push the Handle backward so that the Saw Blade is in behind the stock to be cut.
5. Secure the stock to be cut against the table and fence. If the stock length is short, do not hold with your hand. Use a clamp to hold in place.
6. Adjust the Anti-kickback Arm (15) so it just clears the stock.
7. Press the green Switch (122). Squeeze the Trigger and push the Handle all the way back.
8. When the cut is complete, release the Trigger, push the Handle all the way back, and wait until the saw blade stops completely.

Compound Cross Cutting

Compound crosscutting combines the miter and bevel functions. Set the Saw Blade angles as previously described. Continue to follow steps 4 through 9, above.

In-Rip Cutting

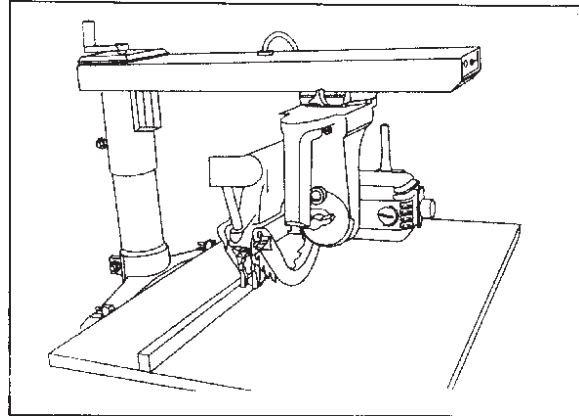

Ripping is the process of cutting stock along the grain (or lengthwise). The stock is fed into the Saw Blade against the blade rotation (similar to a table saw). The fence is used as a guide to help maintain cutting width.

1. Loosen the yoke Clamp Handle (66) and pull out the Yoke Index Knob.
2. Turn the motor assembly to the left and lock the Yoke Index Knob at 90°.
3. Tighten the yoke Clamp Handle (66).
4. Adjust the Saw Blade Safety Guard (7) so it is just above the surface of the stock to be ripped.
5. Adjust the Anti-kickback Arm (13) so it is just above the stock surface.
6. Adjust the Carriage Arm so that the Saw Blade is at the desired depth for the rip cut, and securely lock the Carriage Lock Knob in place. Note that the larger portion of the stock being ripped should be between the Fence and the Saw Blade.
7. Adjust the Elevating Handle (100) so that the Saw Blade is 1/16" into the worktable.
8. Verify that the Bevel Index Knob is locked into 0°.

9. Slide the stock to be ripped into the cutting area and verify that it slides easily beneath the Safety Guard, Anti-kickback Arm, and (optional) Spreader Plate, and there is no wobble space. Remove stock from cutting area.
10. Press the green Switch (122), squeeze the handle Trigger (93) (motor starts), and push up on the Lock On Button.
11. From the side of the machine, feed the stock into the Saw Blade (against its rotation) using a (long) push stick.

WARNING: Do not use your hand to push the stock through the Saw Blade. Do not reach around the Saw Blade while it is running. Serious injury can occur to hands and arms.

12. When the cut is complete, and before removing the stock, squeeze the Trigger or pull down on the Lock On Button, press the red Switch, and wait until the saw blade stops completely.

desired angle (variable or indexed, i.e., 45°).

4. Tighten the Bevel Lock Knob (71) and push in the Bevel Index Knob (74).
5. Press the green Switch (122), squeeze the handle Trigger (motor starts), and push up on the Lock On Button.
6. From the side of the machine, feed the stock into the Saw Blade (against its rotation) using a (long) push stick.

WARNING: Do not use your hand to push the stock through the Saw Blade. Do not reach around the Saw Blade while it is running. Serious injury can occur to hands and arms.

7. When the cut is complete, and before removing the stock, squeeze the Trigger or pull down on the Lock On Button, press the red Switch, and wait until the saw blade stops completely.

Out-Rip Cutting

Out-ripping is done when the in-rip position will not permit a wide enough cut. This function moves the Saw Blade to the front of the machine. This operation is the same as in-rip cutting (previously described), with the exception that the Pivot Yoke is turned so that the Handle is on the right side of the machine (opposite of the in-rip position).

1. Adjust the Saw Blade for In-rip cutting as described on previous page.
2. Loosen the Bevel Lock Knob (71) and pull out the Bevel Index Knob (74).
3. Turn the motor assembly clockwise or counterclockwise, selecting the

MAINTENANCE

CAUTION: Before performing any maintenance, remove the Line Cord from the electrical outlet.

1. Yoke Tightness – Periodically check and tighten the yoke Clamp Handle (66).
Over time this handle may become loose and not tighten entirely. To correct this condition, tighten the large Nut (64) at the base of the Handle using the 5/8" arbor wrench.
2. Cleaning – After each use, apply compressed air to blow clean all the parts of the Radial Arm Saw.
3. Saw Blades – Do not use a replacement blade rated lower than 5,000 RPM, and larger than 8-1/4" diameter.
4. Motor Brushes – Inspect the two motor Brushes (55) after the first 50 hours of saw use. After that, check every 10 hours. Replace if necessary by a qualified technician.
Improper Brush maintenance can cause motor failure. The Brush Caps (56) are located on each side of the motor housing.
5. Lubrication – The Radial Arm Saw does not require initial lubrication. Periodically, however, check all moving parts (i.e., knobs, levers, column shaft, Elevating Handle, shafts) to make sure that they move smoothly. If lubrication is required, use a small amount of light oil. Do not oil the Carriage Arm bearings because they are sealed and do not require lubrication.
6. Motor Preventative Maintenance – In addition to worn motor Brushes, the following are major causes of motor failure:
 - Using a dull or sticking Saw Blade
 - Feeding the stock through the Saw Blade too fast
 - Starting the cut before the Saw Blade has reached full speed
 - Abnormal friction caused by improper alignment of the motor assembly, especially when ripping
 - Low voltage supplied to the machine
 - Buildup of dust in the motor housing, which prevents proper cooling.

Troubleshooting

PROBLEM	CAUSE	SOLUTION
Saw will not make a square crosscut or a good 60° mitre cut.	<ol style="list-style-type: none"> 1. Arm is not perpendicular to the rip fence 2. Too much play between the arm and column 3. Yoke too loose when clamped to carriage 4. Dust between stock and rip fence 5. Table is not parallel with arm 6. Rip Fence is not straight. 7. Rear edge of table A not straight 	<ol style="list-style-type: none"> 1. Adjust the crosscut travel with the rip fence 2. Tighten the column sleeve bolt 3. Adjust Yoke clamp handle 4. Clean worktable 5. Adjust Table A 6. Replace rip fence. 7. Sand or replace Table A
60° cut not accurate	<ol style="list-style-type: none"> 1. Saw Blade not perpendicular to worktable 2. Too much play between arm and column 3. Yoke is too loose when clamped to carriage 4. Bevel Lock Knob is loose 5. Table is not parallel with arm 	<ol style="list-style-type: none"> 1. Adjust Saw Blade 2. Tighten column sleeve bolt 3. Adjust Yoke Clamp Handle 4. Adjust Bevel Lock Knob 5. Adjust Table A
Workpiece has a tendency to walk away from the fence when ripping	<ol style="list-style-type: none"> 1. Saw Blade is not parallel with the fence. 2. Arm is not perpendicular to the rip fence. 	<ol style="list-style-type: none"> 1. Adjust Saw Blade 2. Adjust cross cut travel with rip fence
Saw Blade tends to advance over the stock too fast	<ol style="list-style-type: none"> 1. Dull Saw Blade 2. Not pulling the Saw Blade properly 	<ol style="list-style-type: none"> 1. Replace or sharpen blade 2. Draw Saw Blade across stock with a slow and steady pull
Cut depth varies from one end to the other	Too much play between the arm and column	Tighten column sleeve bolt
Saw does not travel smoothly in arm tracks	<ol style="list-style-type: none"> 1. Dirty tracts 2. Bad Bearings 	<ol style="list-style-type: none"> 1. Clean tracts 2. Replace Bearings
Elevating Handle slips when elevating or lowering the Saw Blade	Screw loose on Elevating Handle	Tighten Screw
Clamping knobs do not hold motor assembly to the set position(s)	Treads stripped on knob(s)	Replace knob(s)
Saw Blade scores workpiece, not giving a good finished cut	<ol style="list-style-type: none"> 1. Saw Blade is leaning to one side 2. Too much play between arm and column 3. Yoke too loose when clamped to carriage 4. Saw Blade bent or dull 5. Not feeding saw properly 6. Using improper Saw Blade for finish cut desired 	<ol style="list-style-type: none"> 1. Adjust Saw Blade square to rip fence 2. Tighten column sleeve bolt 3. Adjust Yoke Clamp Handle 4. Replace Saw Blade 5. Draw the Saw Blade across stock with a slow and steady pull 6. Replace Saw Blade
Saw Blade or dado blades tend to push stock to one side when cross-cutting	<ol style="list-style-type: none"> 1. Saw Blade is heeling 2. Too much play between arm and column 3. Yoke too loose when clamped to carriage 4. Rip fence not straight 5. Dull Saw Blade 	<ol style="list-style-type: none"> 1. Adjust Saw Blade square to the rip fence 2. Tighten column sleeve bolt 3. Adjust Yoke Clamp Handle 4. Replace rip fence 5. Replace or sharpen Saw Blade
Saw Blade Stalls when ripping	<ol style="list-style-type: none"> 1. Arbor Nut loose 2. Dull Saw Blade 3. Saw Blade not parallel to fence 	<ol style="list-style-type: none"> 1. Tighten 2. Replace or sharpen 3. Adjust Saw Blade or fence to parallel
Motor will not reach full speed or power	<ol style="list-style-type: none"> 1. Faulty ON/OFF Switch 2. Circuit overloaded with other appliances 3. Motor windings burned out 4. Circuit used is under rated for this application 	<ol style="list-style-type: none"> 1. Have the Switch unit checked by a qualified technician 2. Use a different circuit for the machine 3. Replace motor 4. Use a different circuit with sufficient power for this machine
Motor overheats, stalls, trips the circuit breakers or fuses	<ol style="list-style-type: none"> 1. Overloaded motor 2. Improper cooling caused by excessive sawdust accumulation around the motor 3. Motor winding burned out or open 4. Power source circuit breakers do not have sufficient power capacity 	<ol style="list-style-type: none"> 1. Feed stock into Saw Blade more slowly 2. Clean motor housing with compressed air 3. Replace motor using a qualified technician 4. Install proper size circuit breakers or change circuits to one with more capacity

PARTS LIST

Part	Description	Q'ty	Part	Description	Q'ty	Part	Description	Q'ty
1	Nameplate	1	55	Carbon Brush	2	108	Arm	1
2	Screw M5×8	2	56	Brush Cap	2	108-1	Countersunk Flat Head Screw	8
3	Washer 5	1	57	Tilt Stop Bolt	1	108-2	Rail	2
4	Dust Guide	1	58	Pressure Spring (2)	1	109	Scale Label (Right)	1
5	Yoke Index Knob	3	59	Handle Cover	1	110	Feed Screw	1
6	Nut M6	69	60	Tapping Screw St3.9×12	2	111	Cable	1
7	Guard Clamping Screw	1	61	Tapping Screw St2.9×6.5	2	112	Arm Base	1
8	Flexible Guard	1	62	Handle Cover	1	113	Washer 12	1
9	Label	1	63	Spring Pin 4×20	1	114	Pressure Spring (5)	2
10	Safety Guard	1	64	Collet Nut	1	115	Bolt M12×60	1
11	Guard Plate	1	65	Screw M5×8	1	116	Buffer Piece	2
12	Spring Washer 5	1	66	Clamp Handle	1	117	Nut M12	2
13	Anti-kickback Arm Ass'y	1	67	Spring Board	2	118	Cable Cover	1
14	Stud Bolt	1	68	Scale Label Board	1	119	Pressure Spring (5)	1
15	Bolt M8×14(left)	1	69	Dial Disc	1	120	Fixed Bolster	1
16	Outside Flange	1	70	Tapping Screw St4.8×16	6	121	Cable Binder	1
17	Saw Blade	1	71	Bevel Lock Knob	1	122	Switch	1
18	Inside Flange	1	72	Pressure Spring (1)	1	123	Switch Case	1
19	Gear Shaft	1	73	C-clip	1	124	Key	1
20	Pressure Spring (1)	1	74a	Bevel Lock Knob	1	125	Table A	1
21	Retaining Ring 6	1	74b	Carriage Lock Knob	1	126	Table B	1
22	Stopper Pin	1	75	Knob Pin	1	127	Table C	1
23	Key B4×22	1	76	Bearing Shaft	4	128	Guide Post Nut	1
24	Tapping Screw St4.8×38	2	77	Bearing 60029	4	129	C-clip	1
25	Screw M5×20	1	78	Stopper Shaft	1	130	Spring Pin 6×12	2
26	Gear Case Cover	1	79	Thin Washer 16	2	131	Column	1
27	Screw M4×8	2	80	Carriage	1	132	Guide Rail	1
28	Bearing 80104	1	81	Spring Washer 8	8	133	Screw M5×10	1
29	Stopper Washer	1	82	Nut M8	8	134	Spacer	1
30	Output Gear	1	83	Washer 6	5	135	Washer 4	2
31	Retaining Ring 20	1	84	Fixed Spring Leaf	1	136	Gauge	1
32	Needle Bearing K101410	1	85	Hex. Head Bolt	1	137	Screw Clamp	2
33	Wood Screw 5×70	2	86	Switch Baffle	1	138	Column Clamping Washer	1
34	Thin Washer 12	2	87	Handle A	1	139	Screw M5×12	1
35	Middle Shaft	1	88	Pressure Spring (4)	1	140	Washer 12	1
36	Needle Bearing K121613	1	89	Cross Baffle	1	141	Arm Lock Bolt M12×65	1
37	Middle Gear	1	90	Spacer	1	142	Arm Index Knob	1
38	Tapping Screw St4.8×32	4	91	Pressure Spring (4)	1	143	Pressure Spring (3)	1
39	Gear Case Cover	1	92	Lock On Button	1	144	C-clip	1
40	Bearing 80102	2	93	Trigger	1	145	Column Base	1
41	Fan Guide	1	94	Screw M6×16	2	146	Table Clamp	2
42	Fan	1	95	Washer 6	2	147	Bolt M8×14	4
43	Rotor	1	96	Spring Washer 6	2	148	Round Head Bolt M8×16	4
44	Stator	1	97	Handle B	1	149	Washer M8	4
45	Cable Coil	5	98	Screw M6×12	5	150	Stand	2
46	Cable Clip	1	99	Spring Washer 6	5	151	Fixed Base (Right)	1
47	Tapping Screw St3.5×9.5	1	100	Elevating Handle	1	152	Base	1
48	Cable Cover	1	101	Arm Cap	1	153	Fixed Base (Left)	1
49	Tapping Screw St3.9×16	2	102	Screw M4×12	2	154	Round Head Bolt M6×16	4
50	Screw M4×10	2	103	Collet Nut M14	1	165	Screw M6 x 16	4
51	End Cap	1	104	Washer 14	1	166	Housing	1
52	Grip Nut	1	105	Cord Clamp	1	167	Bushing	1
53	Conical Collet Chuck	1	106	Lead Wire	1			
54	Brush Holder	2	107	Scale Label (Left)	1			

ASSEMBLY DIAGRAM (1-97)

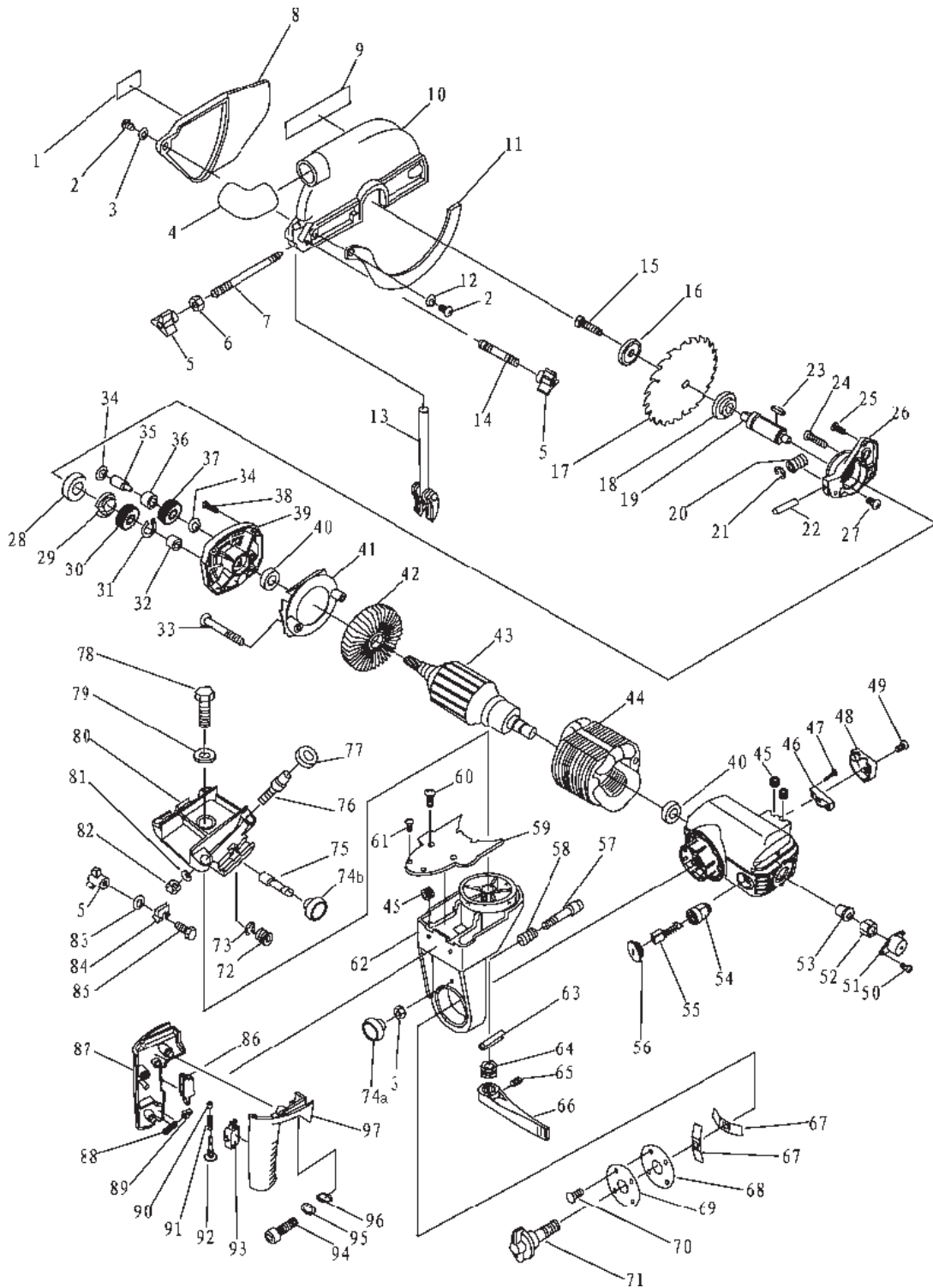

Record Product's Serial Number Here: _____

Note: If product has no serial number, record month and year of purchase instead.

Note: Some parts are listed and shown for illustration purposes only, and are not available individually as replacement parts.

ASSEMBLY DIAGRAM (98-167)

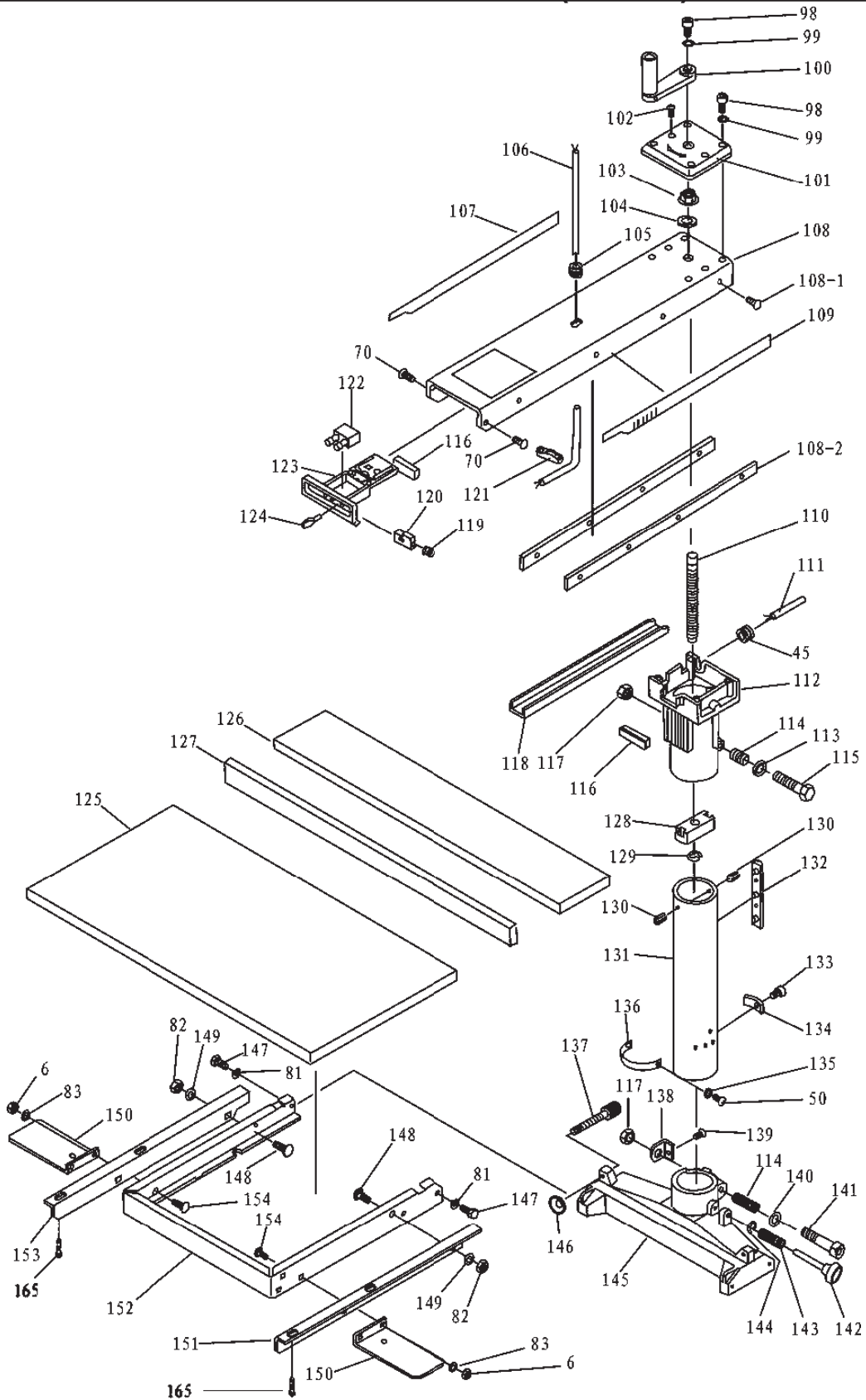

PLEASE READ THE FOLLOWING CAREFULLY

THE MANUFACTURER AND/OR DISTRIBUTOR HAS PROVIDED THE PARTS DIAGRAM IN THIS MANUAL AS A REFERENCE TOOL ONLY. NEITHER THE MANUFACTURER NOR DISTRIBUTOR MAKES ANY REPRESENTATION OR WARRANTY OF ANY KIND TO THE BUYER THAT HE OR SHE IS QUALIFIED TO MAKE ANY REPAIRS TO THE PRODUCT OR THAT HE OR SHE IS QUALIFIED TO REPLACE ANY PARTS OF THE PRODUCT. IN FACT, THE MANUFACTURER AND/OR DISTRIBUTOR EXPRESSLY STATES THAT ALL REPAIRS AND PARTS REPLACEMENTS SHOULD BE UNDERTAKEN BY CERTIFIED AND LICENSED TECHNICIANS AND NOT BY THE BUYER. THE BUYER ASSUMES ALL RISK AND LIABILITY ARISING OUT OF HIS OR HER REPAIRS TO THE ORIGINAL PRODUCT OR REPLACEMENT PARTS THERETO, OR ARISING OUT OF HIS OR HER INSTALLATION OF REPLACEMENT PARTS THERETO.

LIMITED 90 DAY WARRANTY

Harbor Freight Tools Co. makes every effort to assure that its products meet high quality and durability standards, and warrants to the original purchaser that this product is free from defects in materials and workmanship for the period of 90 days from the date of purchase. This warranty does not apply to damage due directly or indirectly, to misuse, abuse, negligence or accidents, repairs or alterations outside our facilities, criminal activity, improper installation, normal wear and tear, or to lack of maintenance. We shall in no event be liable for death, injuries to persons or property, or for incidental, contingent, special or consequential damages arising from the use of our product. Some states do not allow the exclusion or limitation of incidental or consequential damages, so the above limitation of exclusion may not apply to you. THIS WARRANTY IS EXPRESSLY IN LIEU OF ALL OTHER WARRANTIES, EXPRESS OR IMPLIED, INCLUDING THE WARRANTIES OF MERCHANTABILITY AND FITNESS.

To take advantage of this warranty, the product or part must be returned to us with transportation charges prepaid. Proof of purchase date and an explanation of the complaint must accompany the merchandise. If our inspection verifies the defect, we will either repair or replace the product at our election or we may elect to refund the purchase price if we cannot readily and quickly provide you with a replacement. We will return repaired products at our expense, but if we determine there is no defect, or that the defect resulted from causes not within the scope of our warranty, then you must bear the cost of returning the product.

This warranty gives you specific legal rights and you may also have other rights which vary from state to state.

3491 Mission Oaks Blvd. • PO Box 6009 • Camarillo, CA 93011 • (800) 444-3353

Free Manuals Download Website

<http://myh66.com>

<http://usermanuals.us>

<http://www.somanuals.com>

<http://www.4manuals.cc>

<http://www.manual-lib.com>

<http://www.404manual.com>

<http://www.luxmanual.com>

<http://aubethermostatmanual.com>

Golf course search by state

<http://golfingnear.com>

Email search by domain

<http://emailbydomain.com>

Auto manuals search

<http://auto.somanuals.com>

TV manuals search

<http://tv.somanuals.com>