

AC & DC Power Distribution Panel

PN 8408 / PN 3408 / PN 8508 / PN 3508

Specifications

Material: 0.125" 5052-H32 aluminum alloy
Primary Finish: Chemical Treatment per MIL-SPEC C-5541C Final
Panel Finish: Graphite color 2 part textured Polyurethane
Maximum Amperage: Varies by components; busbar maximum 100A
Voltage Rating: 8408 / 3408 12 or 24 Volt DC* / 120 Volt AC Systems
8508 / 3408 12 or 24 Volt DC* / 230 Volt AC Systems

Inches Millimeters

Overall Dimensions: 15-3/4 × 10 400.10 × 254.00

* Configure your panel with the supplied voltage identification labels.

Features

DC 8408 / 3408 / 8508 / 3508

- One 100 Ampere C-Series DC main circuit breaker
- Eighteen circuit breaker positions, twelve 15 Ampere branch circuit breakers installed
- DC digital multimeter PN 8248 with remote shunt and battery bank selector switch

AC 8408 / 3408

- Eight circuit breaker positions, one 30A AC Main circuit breaker and three 15A branch circuit breakers installed
- AC digital multimeter PN 8247

AC 8508 / 3508

- Eight circuit breaker positions, one 16A AC Main circuit breaker and three 8A branch circuit breakers installed
- AC digital multimeter PN 8247

Guarantee

Any Blue Sea Systems product with which a customer is not satisfied may be returned for a refund or replacement at any time. Reference Blue Sea Systems' Digital Meter installation manual for specific meter warranty information.

9089 Rev. 006



WARNING



- ✓ These instructions are intended to provide assistance with the installation of this product, and are not a substitute for a more comprehensive understanding of electrical systems. We strongly recommend that a competent electrical professional perform the installation of this product.
- ✓ If either the panel front or back is to be exposed to water it must be protected with a waterproof shield.
- ✓ The panels must not be installed in explosive environments such as gasoline engine rooms or battery compartments as the circuit breakers are not ignition protected.
- ✓ The main positive connection must be disconnected at the battery post to avoid the possibility of a short circuit during the installation of this distribution panel.
- ✓ The shunt must be installed in the negative line to avoid damage to the meter. Positive voltage applied to digital meter terminals #4 and #5 will cause damage to the meter not covered by warranty.
- ✓ The vessel's shore power cord must be disconnected from shoreside power before installing this electrical panel.
- ✓ If an inverter is installed on the vessel its power leads must be disconnected at the battery before the panel installation. Be aware that many inverters have a "sleep mode" in which their voltage potential may not be detectable with measuring equipment.
- ✓ If an AC Generator is installed aboard it must be stopped and rendered inoperable before the panel is installed.
- ✓ Verify that no other AC source is connected to the vessel's wiring before the panel is installed.

Questions and Comments

We invite your questions and comments. You may contact us at the address below. To find out more about our full line of marine electrical products visit our web site at www.blueseasystems.com.

Blue Sea Systems Inc.
425 Sequoia Drive
Bellingham, WA 98226 USA

Phone (360) 738-8230
Fax (360) 734-4195
www.blueseasystems.com

Installation Set Up

1. Disconnect all AC and DC power

Disconnect all AC power originating on or off the vessel. This includes inverters, generators, shore power attachments and any other device capable of supplying AC power to the ship's circuits.

Disconnect the main positive DC cable from all batteries to eliminate the possibility of a short circuit and to disable the inverter while installing the distribution panel.

2. Apply Voltage Label

All panel components are sized for 12 or 24 Volt systems. Use the labels provided to permanently identify the system voltage and its type (DC) as required by ABYC. Apply the appropriate voltage label to the recessed area on the front of the panel.

3. Select mounting location and cut opening

If this panel is to serve as your main shore power disconnect circuit breaker, select a location which is not more than 10 feet from the shore power inlet or the electrical attachment point of a permanently installed shore power cord as measured along the conductors of the feed wires. If it is more than 10 feet, additional fuses or circuit breakers must be installed within 10 feet of the shore power inlet.

Select a mounting location which is protected from water on the panel front and back and is not in an area where flammable vapors from propane, gasoline or lead acid batteries accumulate. The circuit breakers used in marine electrical panels are not ignition protected and may ignite such vapors.

Using the panel template provided, make a cutout in the mounting surface where the distribution panel is to be mounted. Do not yet fasten the panel to the mounting surface.

DC Installation

1. Select positive feed wire and negative return

Determine the positive feed (red) and negative return (black or yellow) wire size by calculating the total amperage of the circuits that will be routed through the panel. Blue Sea Systems' electrical panels are rated at 100 amp total capacity. The positive feed wire must be sized for 3% voltage drop at the 100 amp panel rating or the maximum amperage that will be routed through the panel in any particular installation, whichever is less. It is recommended that the positive feed wire be sized for the full panel capacity, which, in most cases, will require at least 2 AWG wire, assuming a 10 foot wire run between the panel and the batteries in 12 volt systems. Refer to the Wire Sizing Chart for other situations. In the case of panels with two or more columns of breakers, jumpers from positive bus to positive bus and from negative bus to negative bus should be the same size as the positive feed and the negative return wires.

Remember that the length of the circuit is the total of the positive wire from the power source and the negative wire back to the DC Negative Bus. Be certain that there is a fuse or circuit breaker of the correct size protecting the positive feed wire.

2. Install shunt, negative return and positive feed

The DC digital meter shunt must be installed in the negative line of the circuit whose current is to be measured. Refer to the DC meter installation and operation manual prior to installing the shunt. Review the Theory of Operation, Use, Installation Overview, Installing Shunt, Wiring Diagram and Wire by Wire Instruction sections. Observe all warnings regarding the shunt installation.

Connect a negative return wire from the negative bus on the panel to DC negative and ultimately the load side of the shunt. Connect a positive feed wire from the positive bus on the panel to DC positive. Be certain that there is a fuse or circuit breaker of the correct size protecting the positive feed wire.

DC Installation (continued)

3. Install battery bank voltage monitor wires

The panel is supplied with a digital meter and switch to monitor the voltage of three separate sources, usually the batteries. Connect a minimum 16 AWG red wire from each source to be monitored to each of the corresponding input wires of the switch. There should be a 1 ampere fuse in each positive wire near each source.

4. Install branch circuit wires

Determine the proper wire size for each branch circuit using the guidelines in step 4. Verify that the standard 15 amp circuit breakers installed in the panel are large enough for each branch circuit. Remove and replace with a higher amperage any that are undersized. Connect the positive (red) branch circuit wires to the load terminals of each circuit breaker. Connect each negative (black) branch circuit wire to the DC Negative Bus. **DO NOT CONFUSE THE DC NEGATIVE BUS WITH THE DC GROUNDING BUS.**

5. Optional—install grounding system wire

The grounding wire (bare, green or green with yellow stripe and normally non-current carrying) should not be confused with the negative ground wire (black or yellow and normally current carrying).

In *Boatowner's Illustrated Electrical Handbook*, Charlie Wing identifies three purposes of DC Grounding:

1. Holding conductive housings of low voltage (under 50 volts) DC devices at ground potential by providing a low resistance return path for currents accidentally contacting the device cases.
2. Providing a low resistance return path for electrical current, preventing stray currents that may cause corrosion.
3. Grounding metal electrical cases to prevent emission from inside or absorption from outside of radio frequency noise (RFI).

ABYC requires that grounding wires be sized no smaller than one wire size under that required for current carrying conductors supplying the device to which the grounding wire is connected.

6. Installation of Backlight System

Connect the yellow negative wire to the panel negative bus. **Do not confuse with the AC neutral bus.**

To activate the label lights by the boat's battery switch, connect the red positive wire to the DC positive bus. **Do not confuse with the AC hot bus.**

To activate the label lights by an independent switch or breaker, connect the red positive wire to the load side of a DC switch or breaker.

7. Optional Branch LEDs

This panel is supplied with LEDs pre-installed in all optional branch positions. For future expansion of the panel remove the positive leg of the LED from the negative bus and connect it to the load side of the corresponding branch circuit breaker.

Note

This Blue Sea Systems electrical distribution panel is furnished with 15A circuit breakers for DC branch circuits. These ratings will satisfy the vast majority of marine circuit protection situations. As shown in the Wire Sizing Chart, even 16 AWG wire, which is the minimum wire size recommended by ABYC, has an allowable amperage greater than 20A.

AC Installation

1. Install branch circuit wires

Determine the proper wire size for each branch circuit using the chart below. Verify that the standard circuit breakers installed in the panel are correct for each branch circuit. Remove and replace any that are incorrectly sized. The circuit breaker must have a rating less than the allowable amperage of the wire, yet greater than the circuit's continuous current.

Connect each branch circuit hot (black) to the appropriate load terminal. Connect each branch circuit neutral (white) to one of the screws on the neutral bus. Connect each branch safety ground wire (green) to one of the screws of the safety ground bus.

Do not confuse the neutral current carrying wires (sometimes called ground) with the green normally non-current carrying wires (sometimes called grounding). These two wires must be connected only at the source of power, nowhere else.

Wire sizing chart

Use the wire sizing chart below to determine the proper branch and feed circuit wire sizes.

Allowable Amperage of Conductors

Wire Size (AWG)	Outside Engine Spaces	Inside Engine Spaces
16	25.0	21.3
14	35.0	29.8
12	45.0	38.3
10	60.0	51.0
8	80.0	68.0
6	120.0	102.0
4	160.0	136.0
2	210.0	178.5

Note: This chart assumes wire with 105°C insulation rating and no more than 2 conductors are bundled. Not suitable for sizing flexible shore power cords.

2. Install feed circuit wires

Install the feed wires from the shore power inlet or other AC source, referring to the wire sizing chart to select the correct wire size. Connect the black AC hot, white AC neutral and green AC safety ground as shown in the illustration.

If the feed wires are from the shore power inlet or the electrical attachment point of a permanently installed shore power cord and the inlet or attachment point is more than 10 feet from this panel, an additional fuses or circuit breakers must be installed within 10 feet of the shore power inlet. The measurement is made along the conductors.

3. Optional Branch LEDs

This Panel is supplied with LEDs pre-installed in all optional branch positions. For future expansion of the panel remove the hot leg of the LED from the AC Neutral Bus and connect it to the Load side of the branch circuit breaker.

Note

This Blue Sea Systems electrical distribution panel is furnished with 15A or 8A circuit breakers for AC branch circuits. 15A circuit breakers are used in all 120V panels and 8A circuit breakers are used in all 230V panels. These ratings will satisfy the vast majority of marine circuit protection situations.

Panel Mounting and Testing

1. Apply branch circuit labels and mount panel

Apply a label for each circuit from the label set provided. If the appropriate label is not included, extended label sets are available through retail suppliers, and over 500 individual labels are available directly from Blue Sea Systems. Please go to www.blueseasystems.com to order stock or custom labels for specific applications. Fasten the panel to the mounting surface using the screws provided.

2. Testing

- ✓ Reconnect the main positive cable to the battery terminals and turn the main switch on to supply power to the panel. Turn on all branch circuits and test the voltage at the panel. Compare this voltage to the battery terminal voltage to determine that the voltage drop is within 3%. With all branch circuits still on, test the voltage at one device on each circuit to determine that there is a 3% or 10% drop as is appropriate.
- ✓ Connect the vessel's shore power and verify the Reverse Polarity light is not illuminated. If the red Reverse Polarity light is on then either the hot and ground or the hot and neutral wires have been crossed. Starting at the panel, trace the connections back as far as necessary to locate the error.

- ✓ Using a multimeter where the power source is connected to the panel verify:

PN 8408 / PN 3408—120 Volt AC

- a. 120 volts between hot and neutral (nominal, this may vary depending on source voltage)
- b. 120 volts between hot and ground.
- c. 0 volts between neutral and ground

PN 8508 / PN 3508—230 Volt AC

- a. 230 volts between hot and neutral (nominal, this may vary depending on source voltage)
- b. 230 volts between hot and ground.
- c. 0 volts between neutral and ground.

- ✓ Turn on each branch circuit to verify power to each circuit.
- ✓ Review the AC and DC meter installation and operation manual. Reference the Theory of Operation, Use, Installation Overview and operations sections. Verify meter functions.

Reference

Applicable Standards

- American Boat and Yacht Council (ABYC) Standards and Recommended Practices for Small Craft sections: E-1, E-3, E-9.
- United States Coast Guard 33 CFR Sub Part 1, Electrical Systems

Useful Reference Books

- Calder, Nigel (2005). *Boatowner's Mechanical and Electrical Manual* (3d ed). Camden, ME: International Marine / McGraw-Hill.
- Wing, Charlie (2006). *Boatowner's Illustrated Electrical Handbook* (2d ed). Camden, ME: International Marine / McGraw-Hill.

Other Innovative Products from Blue Sea Systems

- 360 Panel System
- Battery Management Solutions
- AC and DC circuit protection devices
- WeatherDeck waterproof circuit breaker panels
- Fuses, fuse blocks, and BusBar
- Analog and digital meters

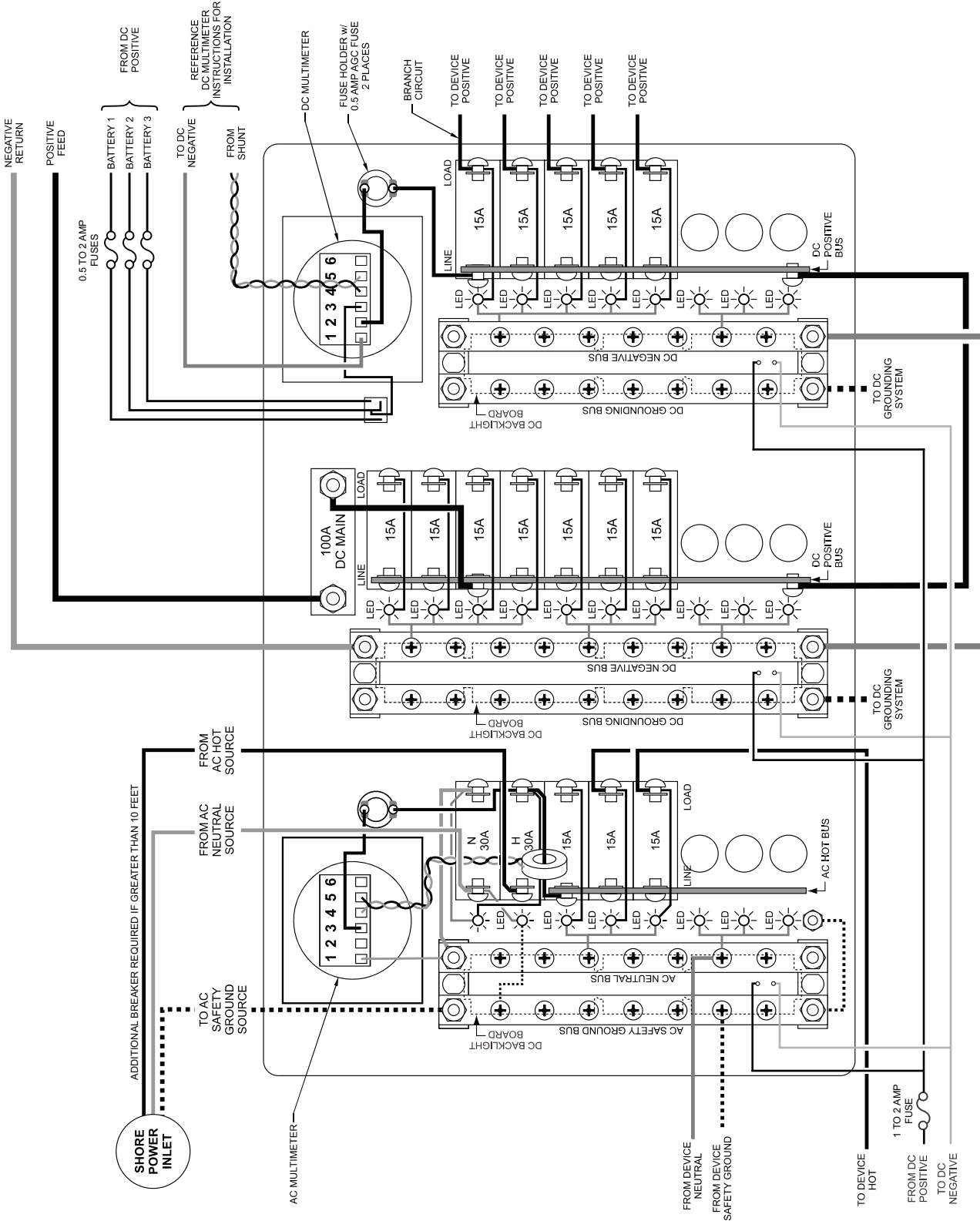

Wiring Diagram
 AC/DC Power Distribution Panel
 with AC & DC Digital Multimeters
 PN 8408 / PN 3408 shown for reference

BLUE SEA SYSTEMS
 Bellingham, WA 98226
 425 Sequoia Drive
 Phone (360)738-8230 Fax (360)734-4195

Free Manuals Download Website

<http://myh66.com>

<http://usermanuals.us>

<http://www.somanuals.com>

<http://www.4manuals.cc>

<http://www.manual-lib.com>

<http://www.404manual.com>

<http://www.luxmanual.com>

<http://aubethermostatmanual.com>

Golf course search by state

<http://golfingnear.com>

Email search by domain

<http://emailbydomain.com>

Auto manuals search

<http://auto.somanuals.com>

TV manuals search

<http://tv.somanuals.com>