

Bolens

Service Manual

Medium Frame Series Tractors

Models

1058	1659
1060	1661
1160	1662
1258	1663
1261	1664
1458	1667
1461	1668
1463	1668L
1467	1669
1468	1669L
1658	1858

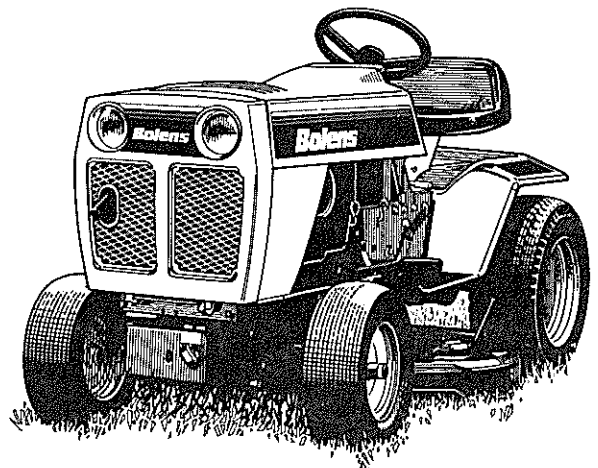

176-2324 (11/90)
SUPERSEDES 553267-8

Medium Frame Series Tractors

I. GENERAL	1
II. ELECTRICAL SYSTEM	2
III. DRIVE TRAIN	3
IV. FUEL SYSTEM	4
V. CHASSIS	5
VI. HYDRAULIC SYSTEM	6
VII. ENGINE	7
VIII. TRACTOR ATTACHMENTS	8

GROUP I. GENERAL

SERIAL NUMBER INFORMATION	1-1
SPECIFICATIONS	1-2
MAINTENANCE CHART	1-5
LUBRICATION POINTS (GEAR DRIVE)	1-6
LUBRICATION CHART (GEAR DRIVE)	1-7
LUBRICATION POINTS (HYDROSTATIC DRIVE)	1-8
LUBRICATION CHART (HYROSTATIC DRIVE)	1-9
TORQUE VALVES, HEX SCREWS	1-10

GROUP II. ELECTRICAL SYSTEM

TROUBLESHOOTING GUIDE	2-1
WIRE COLOR CODE	2-3
WIRING DIAGRAM 1058, 1060, 1160	2-4
WIRING DIAGRAM 1258, 1261, 1458, 1461, 1658, 1661, 1663, 1664, 1858	2-8
WIRING DIAGRAM 1659, 1662	2-13
WIRING DIAGRAM 1667, 1668 (S/N 01-03)	2-14
WIRING DIAGRAM 1467, 1668, 1668L (S/N 04-05)	2-15
WIRING DIAGRAM 1667 (S/N 04)	2-15
WIRING DIAGRAM 1669, 1669L	2-16
WIRING DIAGRAM 1468	2-17
TESTING ELECTRICAL SYSTEM	2-22

GROUP III. DRIVE TRAIN

TROUBLESHOOTING GUIDE	3-1
EATON HYDROSTATIC INTRODUCTION AND REPAIR	3-2
HYDROSTATIC REMOVAL	3-3
HYDROSTATIC BREAKDOWN	3-4
HYDROSTATIC REINSTALLATION	3-5
TRANSAXLE REMOVAL	3-6
TRANSAXLE ASS'Y BREAKDOWN	3-7
TRANSAXLE DISSASSEMBLY	3-8
TRANSAXLE REASSEMBLY	3-10
HYDROSTATIC TRANSAXLE ASSEMBLY	3-11
HYDROSTATIC TRANSAXLE RE-INSTALLATION	3-14
GEAR DRIVE INTRODUCTION	3-16
TRANSAXLE REMOVAL	3-17
GEAR DRIVE TRANSAXLE BREAKDOWN	3-18
TRANSAXLE RE-INSTALLATION	3-20

GROUP IV. FUEL SYSTEM

TROUBLESHOOTING GUIDE	4-1
FUEL TANK AND VALVE	4-2
FUEL FILTER	4-2
AIR CLEANER	4-2
CARBURETOR	4-4

GROUP V. CHASSIS

FRONT WHEEL ALIGNMENT	5-1
STEERING ASSEMBLY	5-1
CLUTCH ADJUSTMENT (GEAR DRIVE)	5-2
BRAKE ADJUSTMENT (GEAR DRIVE)	5-3
HYDROSTATIC TRACTOR ADJUSTMENTS	5-4
INTERLOCK SWITCH ADJUSTMENTS	5-6
MOWER DRIVE ADJUSTMENTS	5-7
ELECTRIC CLUTCH (PTO) ADJUSTMENTS	5-8

GROUP VI. HYDRAULIC SYSTEM

TROUBLESHOOTING GUIDE	6-1
PRINCIPLE OF OPERATION	6-2
TESTING HYDRAULIC SYSTEM	6-3
HYDRAULIC POWER LIFT	6-3
TRANSMISSION FILTERS	6-5

GROUP VII. ENGINE

TROUBLESHOOTING GUIDE	7-1
ENGINE REMOVAL 1058, 1060, 1160	7-3
ENGINE REMOVAL TECUMSEH MODELS	7-4
ENGINE REMOVAL 1467, 1659, 1662, 1667, 1668, 1668L	7-6
ENGINE REMOVAL VANGUARD 1468, 1669, 1669L	7-8

GROUP VIII. TRACTOR ATTACHMENTS

MOWERS	8-1
SNOWTHROWER - SINGLE STAGE	8-5
SNOWTHROWER - TWO STAGE	8-7
TILLER	8-9
POWERPACKER PLUS	8-11

SERIAL NUMBER INFORMATION

The tractor Model/Serial number plate is located on the top of the rear fender under the seat.

1

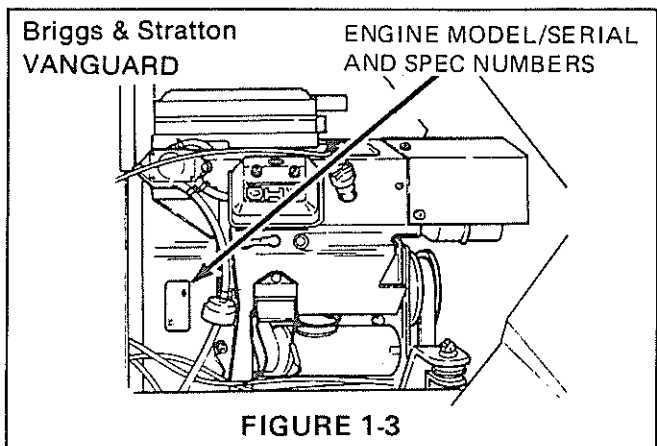
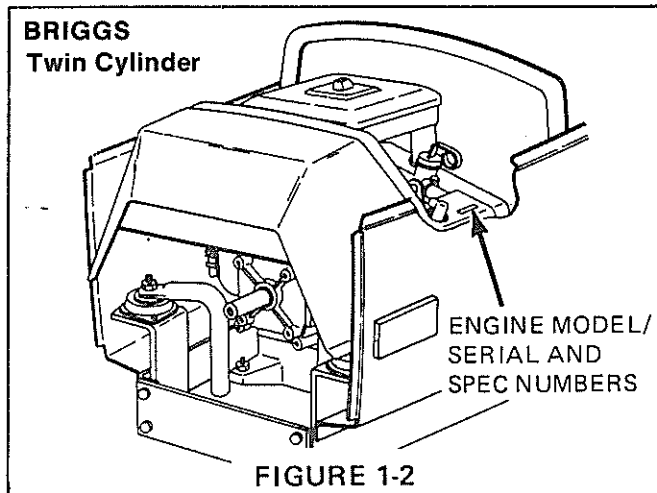
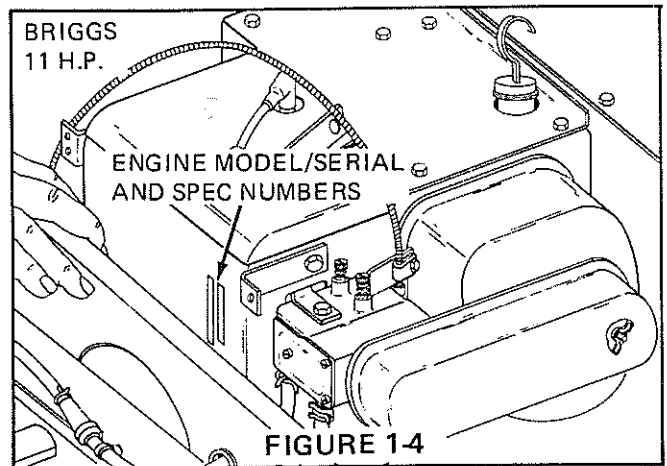
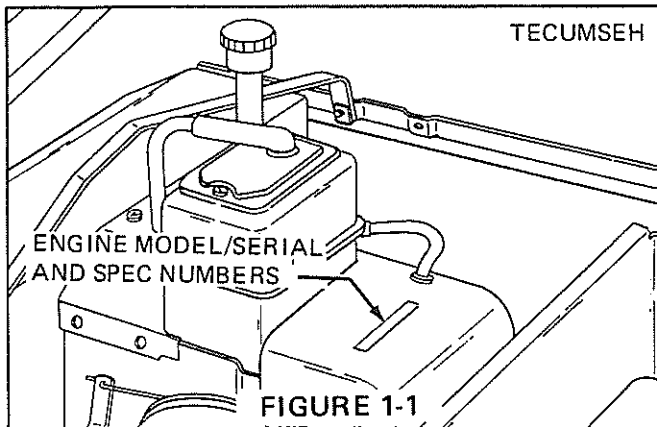

SPECIFICATIONS

Manufacturer	BRIGGS & STRATTON.....	
Model/Spec.....	253417-013101	Models 1058, 1060 & 1160
	400437-012201	Model 1467 (S/N 0100101 thru 0199999)
	400437-120501	Model 1467 (S/N 0200101 and later)
	290447-0108	Model 1468
	402437-066601	Models 1659 & 1662
	402437-066601	Models 1667 & 1668 (S/N 0100101-0299999)
	402437-070001	Models 1667 & 1668 (S/N 0300101-0499999)
	402437-120501	Model 1668, 1668L (S/N 0500101 and later)
	303447-0131	Model 1669, 1669L
Type	Model 253417	Hor. shaft, air cooled, 1 cyl., 4 cycle
	Model 402437	Hor. shaft, air cooled, 2 cyl., 4 cycle
	Model 400437	Hor. shaft, air cooled, 2 cyl., 4 cycle
	Model 290447	Hor. shaft, air cooled, 2 cyl., 4 cycle
	Model 303447	Hor. shaft, air cooled, 2 cyl., 4 cycle
Bore and Stroke (in/mm)	11 HP Models	3.438/87.4 x 2.625/66.5
	14 & 16 Models	3.437/87.31 x 2.156/54.77
Piston Displacement (cu. in./cm)	11 HP Models	24.36/399.5
	14 & 16 HP Models	40/656
Mfr's HP Rating	11 HP Models	11 HP (8.2 kW) @ 3600 RPM
	14 HP Models	14 HP (10.4 kW) @ 3600 RPM
	16 HP Models	16 HP (11.9 kW) @ 3600 RPM
Crankshaft Extension	All Models	1.000/.999 Dia. Keyway, .375-24 Tap
Air Cleaner	All Models	Dry type, with foam precleaner element
Oil Capacity (pts./liters)	All Models	3.0 pints/1.4 liters
Oil Capacity (pts./liters)	Models w/Oil Filters	3.5 pints/1.6 liters
Fuel Capacity (gal./liters)	Models 1060, 1058, 1160, 1659, 1662, 1668L, 1669 & 1669L	1.6 gal./6.1 liters
	Models 1467, 1667 & 1668	3.5 gal./13.2 liters
Governor Setting	All Models	Mechanical-3600 + 150 RPM
Speed Control	All Models	Remote, cable operated
Spark Plug.....	11 HP Models	Champion RCJ8 or equivalent
	14 & 16 HP Models	Champion J-8 or equivalent (Refer to Engine Manual for proper equivalents)
Spark Plug Gap	All Models030 in. (.076 mm)

SPECIFICATIONS



ENGINE

Manufacturer	TECUMSEH	
Model/Spec	OH 120-175007, A	Model 1258, 1261
	OH 140-160027 A, B, C	Model 1458, 1461, 1463
	OH 160-170089 A, B	Model 1658, 1661, 1663, 1664
	OH 180-180002A	Model 1858
Type	All Models	
	Overhead valve, air cooled, 1 cyl., 4 cycle	
Bore and Stroke (in./mm)	OH 120	3.125/79.3 x 2.750/69.9
	OH 140	3.312/84.1 x 2.750/69.9
	OH 160	3.500/88.9 x 2.875/73.0
	OH 180	3.625/92.0 x 2.875/73.0
Piston Displacement (cu. in./cm ³)	OH 120	21.1/345.3
	OH 140	23.7/388.4
	OH 160	27.7/453.3
	OH 180	30.0/490.9
Mfr's H.P. Rating	OH 120	12 H.P. (8.9 kW) @ 3600 RPM
	OH 140	14 H.P. (10.4 kW) @ 3600 RPM
	OH 160	16 H.P. (11.9 kW) @ 3600 RPM
	OH 180	18 H.P. (13.4 kW) @ 3600 RPM
Crankshaft Extension	All Models	1.000/.999 Dia. x 2.86, Std. Keyway, .375-24 Tap
Air Cleaner	All Models	Dry Type
Oil Capacity (pts./liters)	All Models	3.0 pints/1.4 liters
Fuel Capacity (gal./liters)	All Models	1.6 gal./6.1 liters
Governor Setting	All Models	3600 ± 150 RPM - Mechanical
Speed Control	All Models	Remote, cable operated
Spark Plug	All Models	Champion RL85 or equivalent
Spark Plug Gap	All Models030 in. (.076 mm)
Point Gap	All Models	Solid State

SPECIFICATIONS

CHASSIS

TYPE	All Models	Steel formed frame
Height (in./cm)	All Models	44 in. (111.8 cm)
Width (in./cm)	1058, 1060	36-1/4 in. (92 cm)
	All Other Models	Approx. 36-37 in. (91-94 cm)
Length (in./cm)	All Models	70-3/4 in. (179.7 cm)
Wheel Base (in./cm)	All Models	49 in. (123 cm)
Turning Radius (in./cm)	All Models	77 in. (195.6 cm)
Ground Clearance-Rear Axle (in./cm)	All Models	7 in. (17 cm)
Shipping Weight (lbs./kgs)	1058	655 lbs. (297 kgs)
	1060, 1160	600 lbs. (272 kgs)
	1258, 1458, 1658, 1659, 1664,	700 lbs. (318 kgs)
	1261, 1461, 1463, 1661, 1662, 1663, 1667, 1467	703 lbs. (319 kgs)
	1668, 1858	785 lbs. (356 kgs)
Transmission	1060, 1160, 1261, 1461, 1463, 1661, 1662, 1663, 1467, 1468, 1667, All gear; 4 speed & reverse w/transaxle & limited slip differential	
Brakes	Transmission Mounted Disc Brake	
Transmission	1058, 1258, 1458, 1658, 1659, 1664, 1668, 1669, 1669L, 1858 ... Model 11 Eaton hydrostatic w/transaxle; infinite speed range in forward & reverse	
Approx. Max. Speed	Gear Transmission	Forward .7-5.2 mph (1.1-8.4 km/hr.) Reverse 1-2.10 mph (1.6-3.4 km/hr.)
	Hydrostatic Transmission	Forward 0-6.75 mph (0-10.8 km/hr.) Reverse 0-3.50 mph (0.5.6 km/hr.)
Tires	1058, 1060, 1160, 1258, 1261, 1463, 1467, 1468, 1663, 1664, 1667, 1668, 1668L, 1669, 1669L Front 16/6.50-8; Rear 23/8.50-12	
	1461, 1458, 1658, 1659, 1661, 1662, 1858. Front 16/6.50-8 Rear 23/10.50-12	
PTO Type	Electric Clutch	

MAINTENANCE CHART

MAINTENANCE REQUIRED	Length of Operation	Type of Maintenance
Engine Cooling Air Screen -	Tecumseh Models 25 Hrs.* B & S Models - 100 Hrs.*	Brush Clean
Engine Air Cleaner -	25 Hrs.*	Refer to Section 4, FUEL SYSTEM
	When no longer serviceable	Replace
Engine Oil Filter (If Equipped)	100 Hrs.	Replace
Cooling Fins - (Engine) -	Yearly or every 50 Hrs.	Clean - use Air Hose if Available
Spark Plugs -	100 Hrs.	Service or Replace
Breaker Points - (Battery Ignition) -	100 Hrs.*	Service or Replace
Ignition Timing - (Battery Ignition)	100 Hrs.*	Adjust
Fuel Filter -	100 Hrs.*	Replace
Battery -	25 Hrs.	Check Water Level - Add As Necessary
Hydrostatic and Rear Axle Fins - (Hydrostatic Models)	Daily or 10 Hrs.*	Clean - Use Air Hose if Available
Belts -	50 Hrs.*	Check for Wear and Adjust
Tires -	30 Hrs.	Check for Damage and Air Pressure
Transmission Filter - (Hydrostatic)-	After First 5 Hours, then After Every 100 Hours or with oil change	Change - Use Bolens Filter**
Brake -	As Required	Adjust Linkage
Rear Axle -	50 Hrs.*	Adjust End Play

* More often under extreme conditons.

** An equivalent substitute is acceptable.



LUBRICATION POINTS GEAR DRIVE

ENGINE SHOWN IS A 11 HP
BRIGGS & STRATTON. FOR THE
TECUMSEH ENGINE SEE PAGE 1-8.

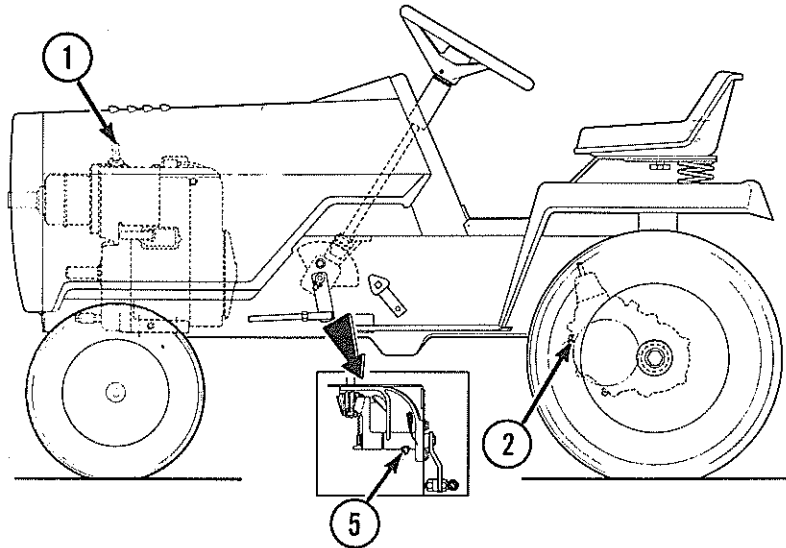

TWIN CYLINDER I.C.
BRIGGS & STRATTON

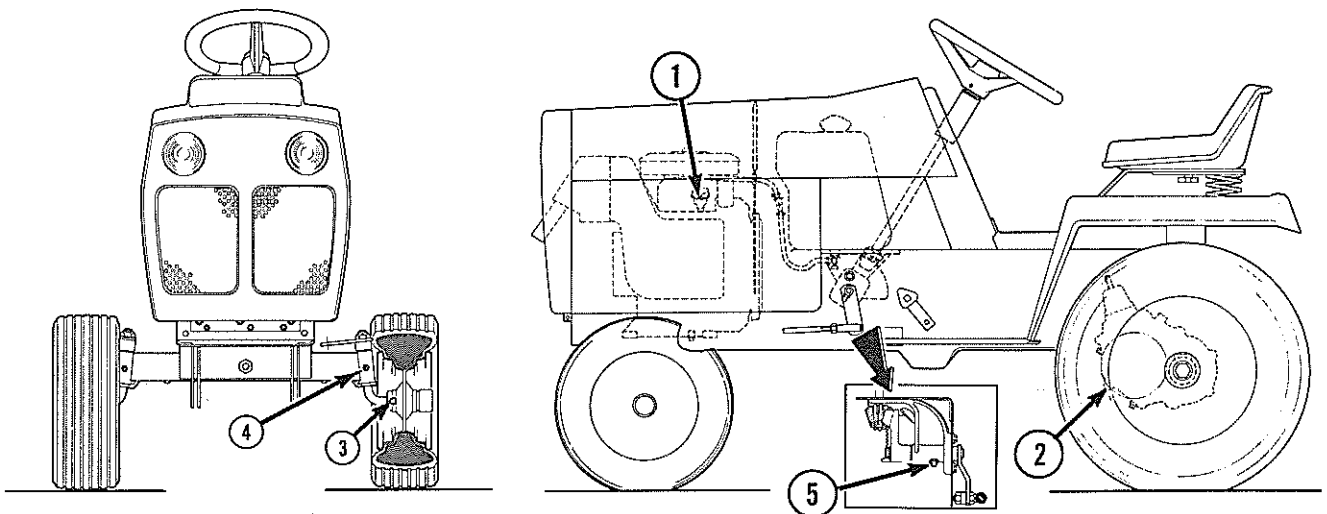

**LUBRICATION CHART
GEAR DRIVE**



LUBRICATION REQUIRED		Length of Operation	Type of Lubrication	Amount Required
1. Engine Crankcase -		After first 2-5 Hrs.	Engine Oil SF, SC, SD or SE	Replacement Quantity: (1) 3 pt. (1.4L) (2) 3-1/4 pt. (1.5L) (3) 3-1/2 pt. (1.6L)
Average Temperature	(Spring, Summer, Autumn) (+120°F. to +40°F.) (49°C. to 4°C.)	25 Hrs.*	SF, SC, SD or SE SAE 30 10-W-30 10-W 40 Oil	
	(Winter) (+40°F. to 0°F. & Lower) (4°C. to -19°C. & Lower)	25 Hrs.*	SAE 5W-30 or 5#-20 Oil Type SF, SC, SD or SE	
2. Transmission -		Check once a year	EP 90 Gear Lube	Add To Plug Level Capacity 3 pints (1.4L)
3. Front Wheel Bearings - (Some Models)		10 Hrs.	Multi-Purpose Grease	1-2 Strokes
4. Front Wheel Spindles -		10 Hrs.	Multi-Purpose Grease	1-2 Strokes
5. Steering Shaft -		10 Hrs.	Multi-Purpose Grease -	1-2 Strokes

* More often under extreme conditions.

NOTE: A hand type grease gun is recommended when greasing your unit. HI-PRESSURE TYPE GREASE GUNS could cause damage to the fittings and bearing seals. Lubricate all linkages, levers and pins not equipped with grease fittings with oil once a week, or more often depending on operating conditions.

- (1) 3 Pt. (1.4L) - Models 1060, 1160, 1467, 1662, 1667
- (2) 3-1/4 Pt. (1.5L) - Models 1261, 1461, 1463, 1661, 1663
- (3) 3-1/2 Pt. (1.6L) - Models 1468

LUBRICATION POINTS HYDROSTATIC DRIVE

ENGINE SHOWN IS A
TECUMSEH. FOR THE
11 HP BRIGGS & STRATTON ENGINE SEE PAGE 1-6.

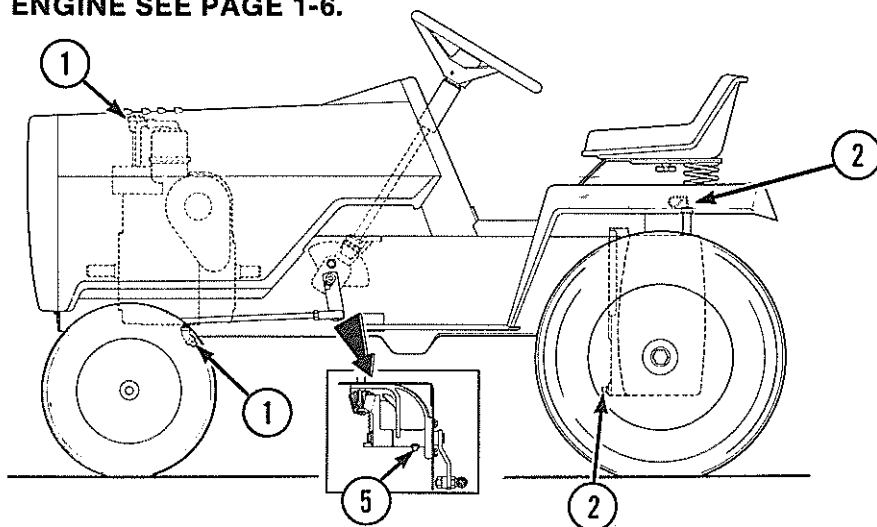

TWIN CYLINDER I.C. BRIGGS & STRATTON

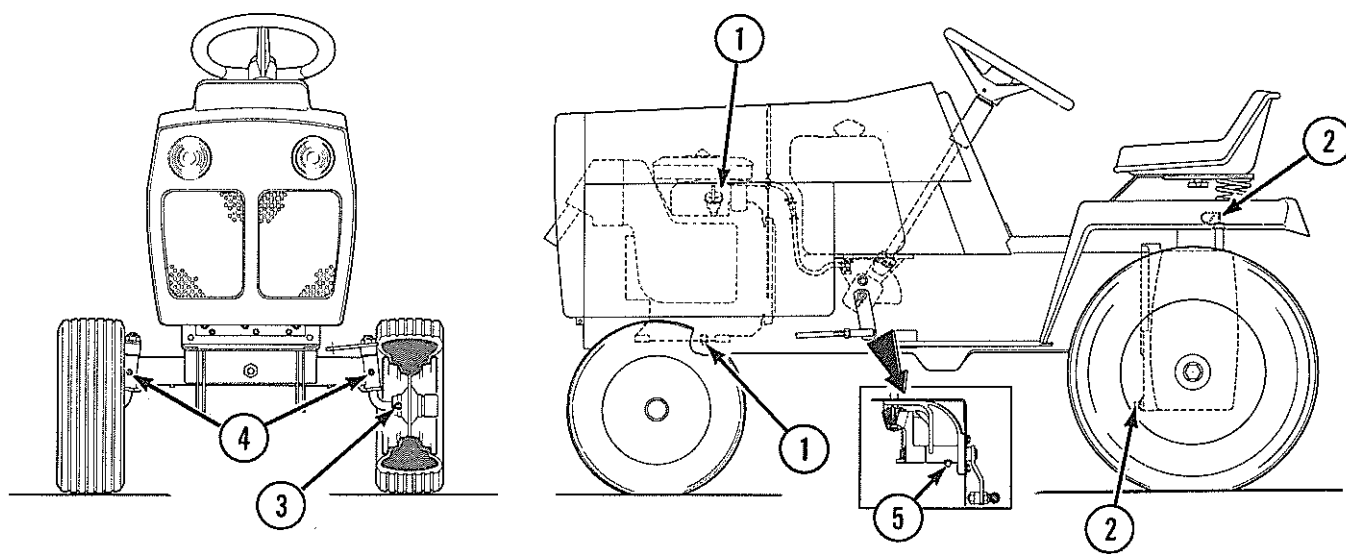

LUBRICATION CHART HYDROSTATIC DRIVE



LUBRICATION REQUIRED		Length of Operation	Type of Lubrication	Amount Required
1. Engine Crankcase -		After first 2-5 Hrs.	Engine Oil SF, SC, SD or SE	Replacement Quantity: (1) 3 pt. (1.4L) (2) 3-1/4 pt. (1.5L) (3) 3-1/2 pt. (1.6L)
Average Temperature	(Spring, Summer, Autumn) (+40°F. to +120°F.) (4°C. to 49°C.)	25 Hrs. *	SAE 30 Oil Type SF, SC, SD or SE 10-W-30, 10W-40	
	(Winter) (+40°F to 0°F. & Lower) (4°C. to -19°C. & Lower)	25 Hrs. *	SAE 5W-30 Oil Type SF, SC, SD, or SE or 5W-20 Oil	
2. Hydrostatic Transmission - (Shipped with SAE 20 oil)		Check Weekly Or 10 Hrs.	*20°F (-6°F) and above SAE 20 oil. Type SC, SD, or SE 20°F (-6°C) and below DRAIN AND REFILL with Recommended Transmission Fluid**	Add To "FULL" Mark on Dipstick Approx. 8 Qts. (7.6L)
		When oil is discolored, dirty or after 250 hrs. (During heavy use every 100 hrs.)	(*DRAIN AND REFILL AS FOLLOWS: 20°F (-6°C) and Above SAE 20 oil Type SC SD or SE - 20°F (-6°C) and Below Drain and refill with Recommended Transmission Fluid**	
3. Front Wheel Bearings -		10 Hrs.	Multi-Purpose Grease	1-2 Strokes
4. Front Wheel Spindles -		10 Hrs.	Multi-Purpose Grease	1-2 Strokes
5. Steering Shaft -		10 Hrs.	Multi-Purpose Grease	1-2 Strokes

* More often under extreme conditions.

** Use SC, SD or SE SAE 30 rated oil if tractor is used under constant heavy load conditions in hot weather (blade, plow, etc.)



NOTE: A hand type grease gun is recommended when greasing your unit. HI-PRESSURE TYPE GREASE GUNS could cause damage to the fittings and bearing seals. Lubricate all linkages, levers and pins not equipped with grease fittings with oil once a week, or more often depending on operating conditions.

(1) 3 Pt. (1.4L) - Models 1058, 1659, 1668, 1668L

(2) 3-1/4 Pt. (1.5L) - Models 1258, 1458, 1658, 1664, 1858

(3) 3-1/2 Pt. (1.6L) - Models 1669, 1669L

TORQUE VALUE FOR CAP SCREWS

SIZE	 SAE GRADE 2			 SAE GRADE 5			 SAE GRADE 8		
	Lb. In.	Nm	Kgm	Lb. In.	Nm	Kgm	Lb. In.	NM	Kgm
1/4 - 20	49	5.5	0.6	75	8.5	0.9	108	12.2	1.2
1/4 - 28	56	6.3	0.6	86	9.7	1.0	120	13.6	1.4
	Lb. Ft.			Lb. Ft.			Lb. Ft.		
5/16 - 18	8	10.8	1.1	13	17.6	1.8	18	24.4	2.4
5/16 - 24	9	12.2	1.2	14	18.9	1.9	20	27.1	2.7
3/8 - 16	15	20.3	2.0	23	31.2	3.1	35	47.4	4.8
3/8 - 24	17	23.0	2.3	25	33.9	3.4	35	47.4	4.8
7/16 - 14	24	32.5	3.3	35	47.4	4.8	55	74.5	7.6
7/16 - 20	25	33.9	3.4	40	54.2	5.5	60	81.3	8.3
1/2 - 13	35	47.4	4.8	55	74.5	7.6	80	108.4	11.0
1/2 - 20	40	54.2	5.5	65	88.1	9.0	90	122.0	12.4
9/16 - 12	55	74.5	7.6	80	108.4	11.0	110	149.1	15.2
9/16 - 18	60	81.3	8.3	90	122.0	12.4	130	176.2	18.0
5/8 - 11	75	101.6	10.3	110	149.1	15.2	170	230.4	23.5
5/8 - 18	85	115.2	11.7	130	176.2	18.0	180	243.9	24.9
3/4 - 10	130	176.2	18.0	200	271.0	27.7	280	379.4	38.7
3/4 - 16	145	196.5	20.0	220	298.1	30.4	320	433.6	44.3
7/8 - 9	125	169.4	17.3	320	433.6	44.3	460	623.3	63.7
7/8 - 14	140	189.7	19.3	350	474.3	48.4	500	677.5	69.2
1 - 8	190	257.5	26.3	480	650.4	66.5	680	921.4	94.2
1 - 12	200	271.0	27.7	530	718.2	73.4	740	1002.7	102.5

Conversion Formula: To obtain Nm multiply ft. lbs by 1.355.
To obtain Kgm multiply ft. lbs by 0.138

All torques $\pm 10\%$ unless otherwise specified.
All torque values are for capscrews that have been lubricated with engine oil or grease.

Multiply standard assembly torque by the following factors:

- A. 1.25 when threads are dry
- B. 0.85 when parts are plated
- C. 0.75 when parts are parkerized
- D. 0.70 when parts are coated with Molykote
- E. 0.65 for jam nuts

TROUBLE SHOOTING GUIDE

PROBLEM	PROBABLE CAUSE	REMEDY
Starter Motor does not energize and solenoid does not click.	<ol style="list-style-type: none"> 1. Attachment drive engaged. 2. Brake pedal not depressed. 3. Corroded or loose electrical solenoid connections. 4. Inoperative switches - Attachment drive, brake and key switch. 5. Inoperative solenoid. 6. Defective key switch. 	<ol style="list-style-type: none"> 1. Disengage PTO. 2. Depress brake pedal. 3. Clean and tighten Red/White wire at solenoid. 4. Check and replace if necessary. (Refer to switch testing.) 5. Check and replace if necessary. (Refer to solenoid testing.) 6. Check and replace if necessary. (Refer to ignition switch test.)
Starter Motor does not energize but solenoid clicks.	<ol style="list-style-type: none"> 1. Discharged battery. 2. Corroded or loose electrical connections on solenoid, or starter. 3. Defective solenoid. 	<ol style="list-style-type: none"> 1. Charge battery. 2. Check solenoid or starter. 3. Check and replace if necessary.
Engine cranks slowly.	<ol style="list-style-type: none"> 1. Weak or discharged battery. 2. Corroded or loose electrical connections at battery. 	<ol style="list-style-type: none"> 1. Check battery, charge or replace if necessary. 2. Clean and tighten.
Battery discharges rapidly.	<ol style="list-style-type: none"> 1. Low water level. 2. Defective battery. 	<ol style="list-style-type: none"> 1. Check and refill. 2. Check and replace if necessary.
Battery will not charge.	<ol style="list-style-type: none"> 1. Corroded or loose battery cables. 2. Defective battery. 3. Inoperative diode or rectifier/regulator. 	<ol style="list-style-type: none"> 1. Clean and tighten. 2. Replace battery. 3. Check diode and replace if necessary. Check rectifier/regulator by substitutions. (Refer to diode test.)

2

ELECTRICAL SYSTEM (Continued)

TROUBLE SHOOTING GUIDE

PROBLEM	PROBABLE CAUSE	REMEDY
Lights not operating.	<ol style="list-style-type: none"> 1. Bulbs burned out. 2. Loose or broken white or black wire. 3. Light switch. 	<ol style="list-style-type: none"> 1. Replace bulbs. 2. Replace wires or tighten connections. 3. Check for broken switch & replace.
Attachment drive inoperative (Attachment drive light works).	<ol style="list-style-type: none"> 1. Broken or loose wires. 2. Electric clutch. 	<ol style="list-style-type: none"> 1. Check purple wire between PTO switch and electric clutch for breaks or poor connections & repair. 2. Check clutch plate gap & adjust. Refer to PTO section.
Attachment drive inoperative (Attachment light inoperative).	<ol style="list-style-type: none"> 1. Attachment drive switch. 2. Broken red wire between Attachment drive switch and key switch. 	<ol style="list-style-type: none"> 1. Check and replace if necessary. Refer to Attachment switch test. 2. Check and replace if necessary.
Engine kills when Attachment drive switch is turned on.	<ol style="list-style-type: none"> 1. No operator in tractor seat. 2. Seat switch is not adjusted properly. 	<ol style="list-style-type: none"> 1. Seat switch must be activated by operator weight 2. Adjust so switch is functional when operator is seated.
Continued operation of attachments when operator is not seated.	<ol style="list-style-type: none"> 1. Seat switch is not adjusted correctly. 2. Seat switch. 3. Broken wires. 4. Attachment drive switch. 5. Condensor. 	<ol style="list-style-type: none"> 1. Adjust so switch is functional when operator is not seated. 2. Check and replace if necessary. Refer to seat switch test. 3. Connect or repair blue wires between seat switch and Attachment drive 4. Check and replace if necessary. Refer to attachment drive switch test. 5. Check and replace if necessary.

ELECTRICAL SYSTEM WIRE COLOR CODE

<u>COLOR</u>	<u>FUNCTION</u>	<u>EXPLANATION</u>
Black	Ground	—
Black/Yellow	Solenoid Ground	Lead between solenoid and ground switch
Red	Switched 12 Volts	"Run" or "On" Key Position
Red/White	Amp Meter Pos. Terminal	For Amp Meter polarity indication
Red/Black	Amp Meter Neg. Terminal	Amp Meter polarity indication
Red/Yellow	Start Circuit	12 Volts start position only
Orange	Ignition Circuit	12 Volts during run and start position
Yellow	Stator Leads	—
Yellow/Red	Stator Leads	To indicate polarity on 2nd wire
Blue	Stop Circuit	From engine kill circuit
Blue/Black	Safety Interlock	Accessory Stop Circuit
White	Lights	—
White/Green	Hi Beam	Function of light circuit
White/Blue	Lo Beam	Function of light circuit
White/Red	Brake Light	Function of light circuit
White/Black	Back Up Light	Function of light circuit
Brown	Tach	—
Brown/Orange	Tach Signal	Obtained from 12 volt ignition coil
Brown/Yellow	Tach Signal	Obtained from stator
Purple	P.T.O. Clutch	—
Green	Temperature	Lead used between sender and indicator
Gray	Oil Pressure	Lead used between sender and indicator

2

Some of the products from Vendors will not match our color system. Generally the Vendor uses black wire; however, we will try to interrupt this difference by using a connector located near the Vendor item.

COMPLETE WIRING DIAGRAM
1058, 1060 AND 1160 S/N 0100101 AND UP

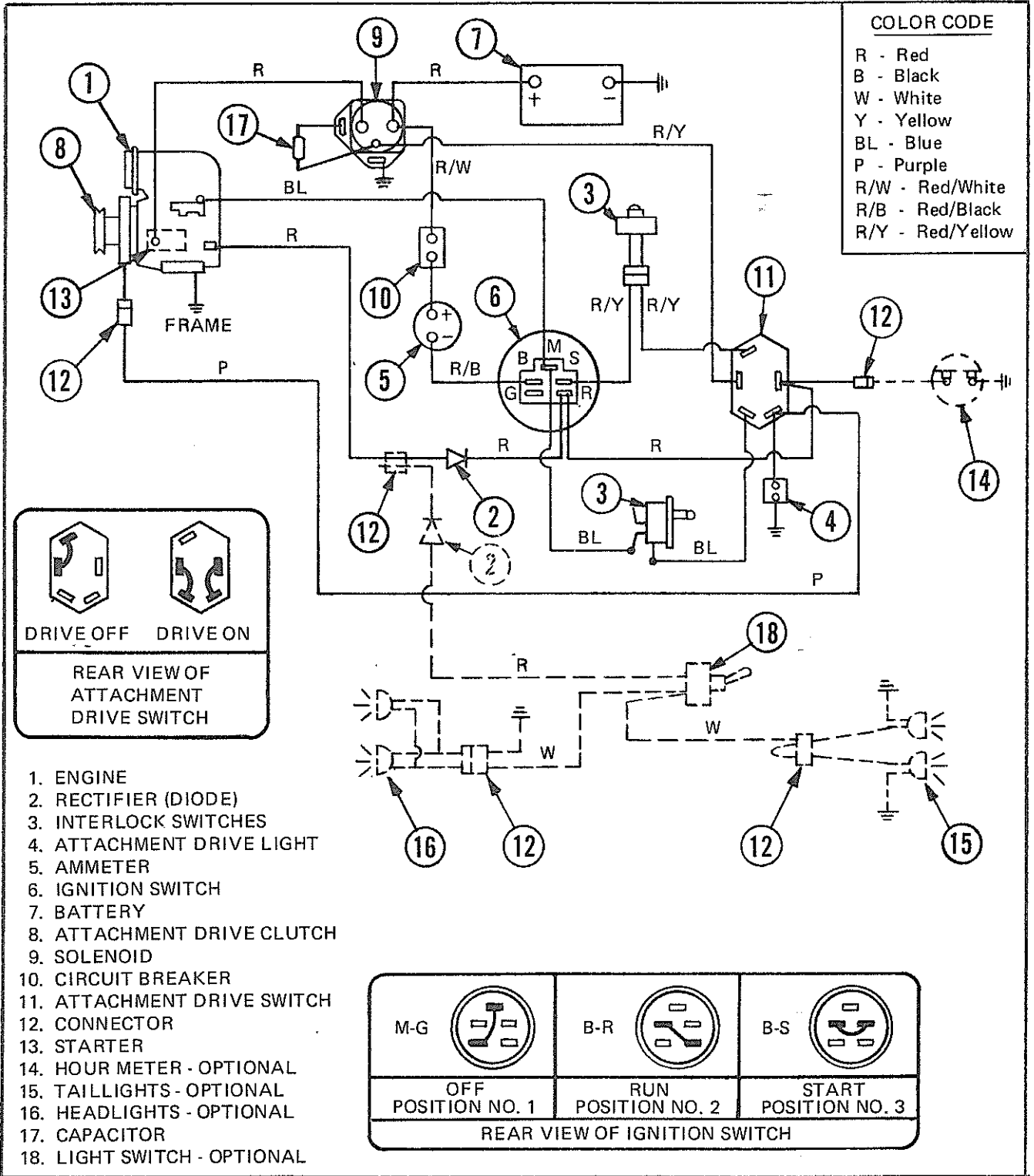

CIRCUIT DIAGRAM

1058, 1060 AND 1160 S/N 0100101 AND UP

START CIRCUIT

(Ignition switch in "START" position, Attachment switch OFF and Brake switch depressed.)

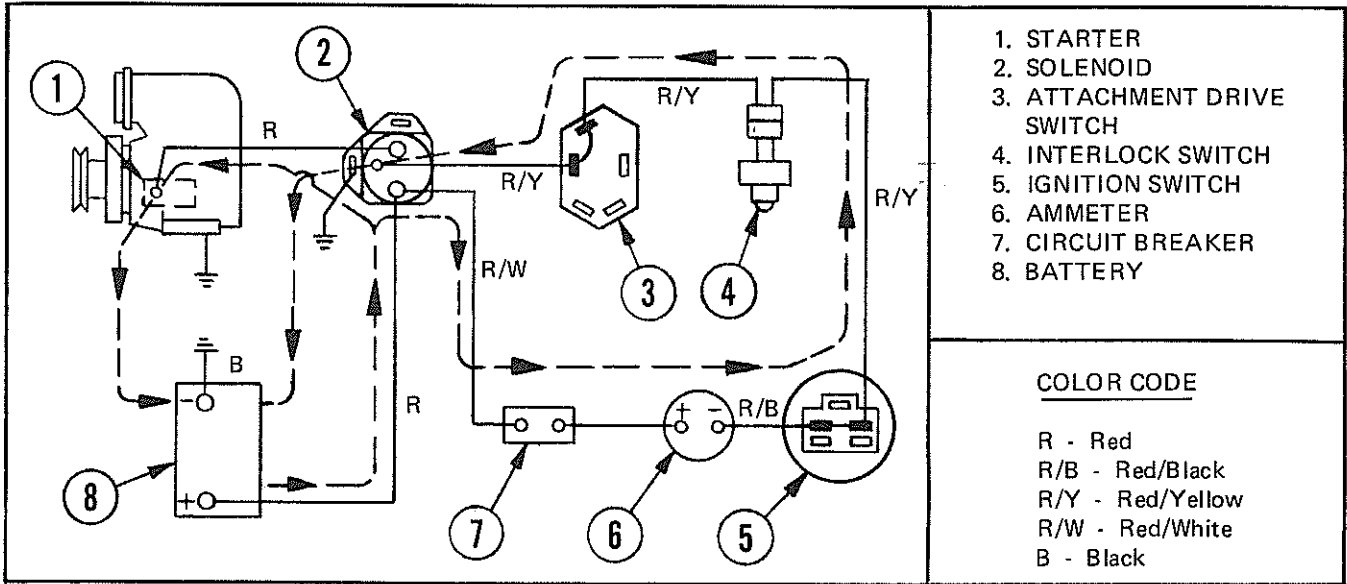

2

LIGHT CIRCUIT

(Light switch ON)

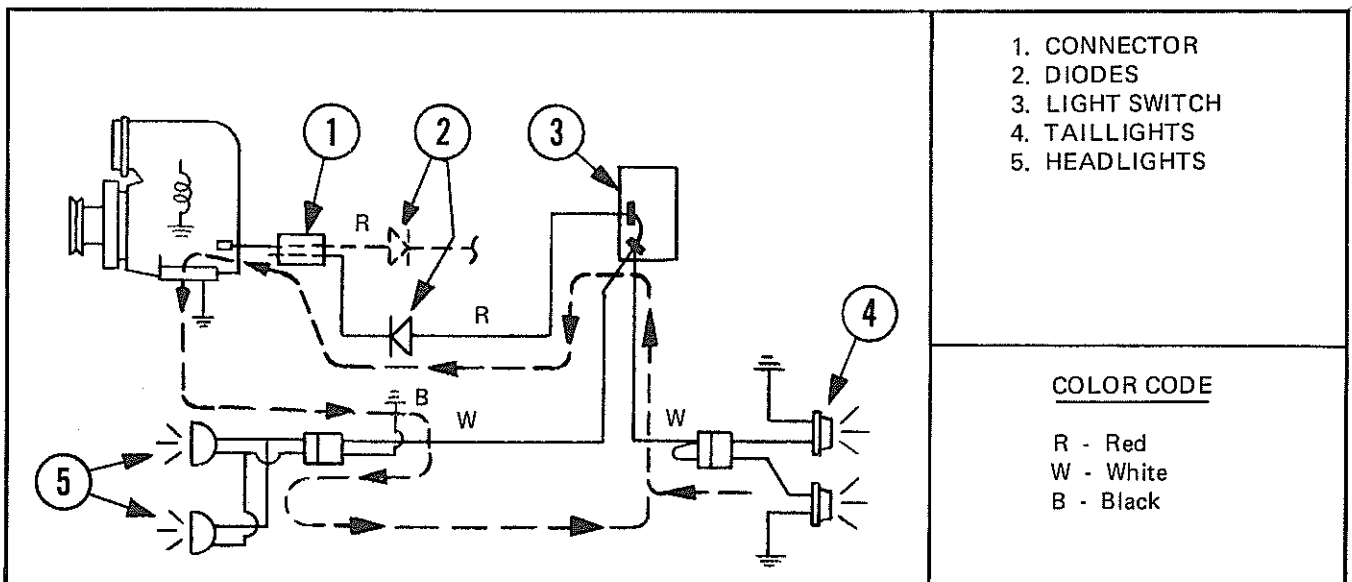

CIRCUIT DIAGRAM

1058, 1060 AND 1160 S/N 0100101 AND UP

CHARGING CIRCUIT
(Ignition switch in "RUN" position)

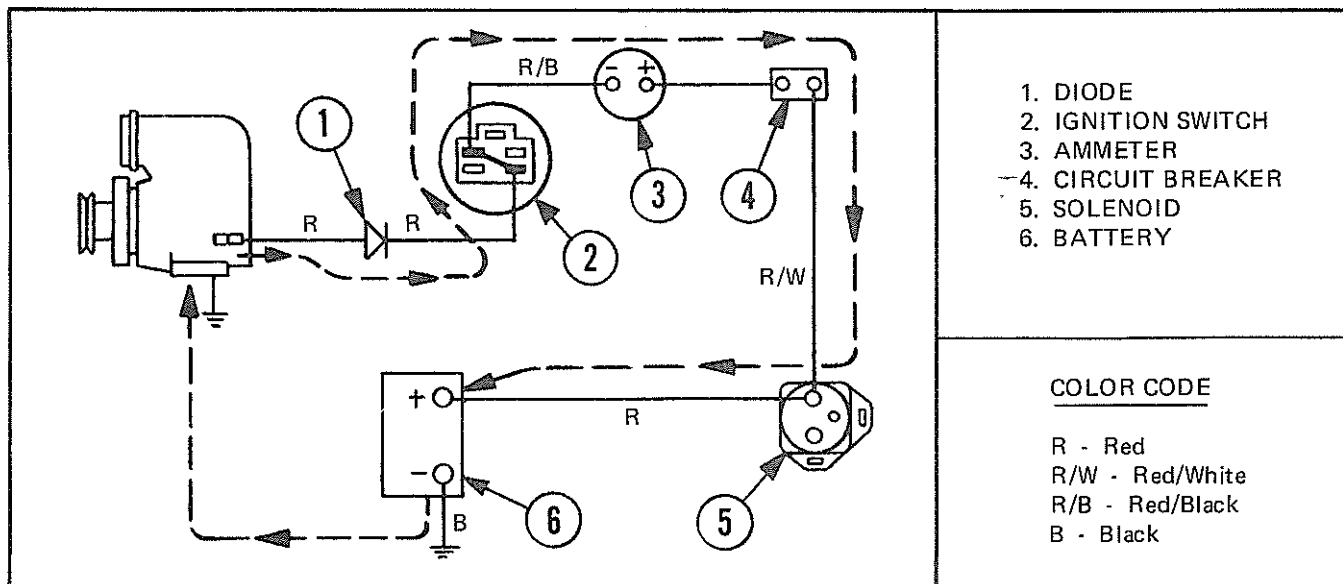

1. DIODE
2. IGNITION SWITCH
3. AMMETER
4. CIRCUIT BREAKER
5. SOLENOID
6. BATTERY

COLOR CODE

- R - Red
- R/W - Red/White
- R/B - Red/Black
- B - Black

ATTACHMENT DRIVE CIRCUIT

(Ignition switch in "RUN" position and Attachment switch in ON)

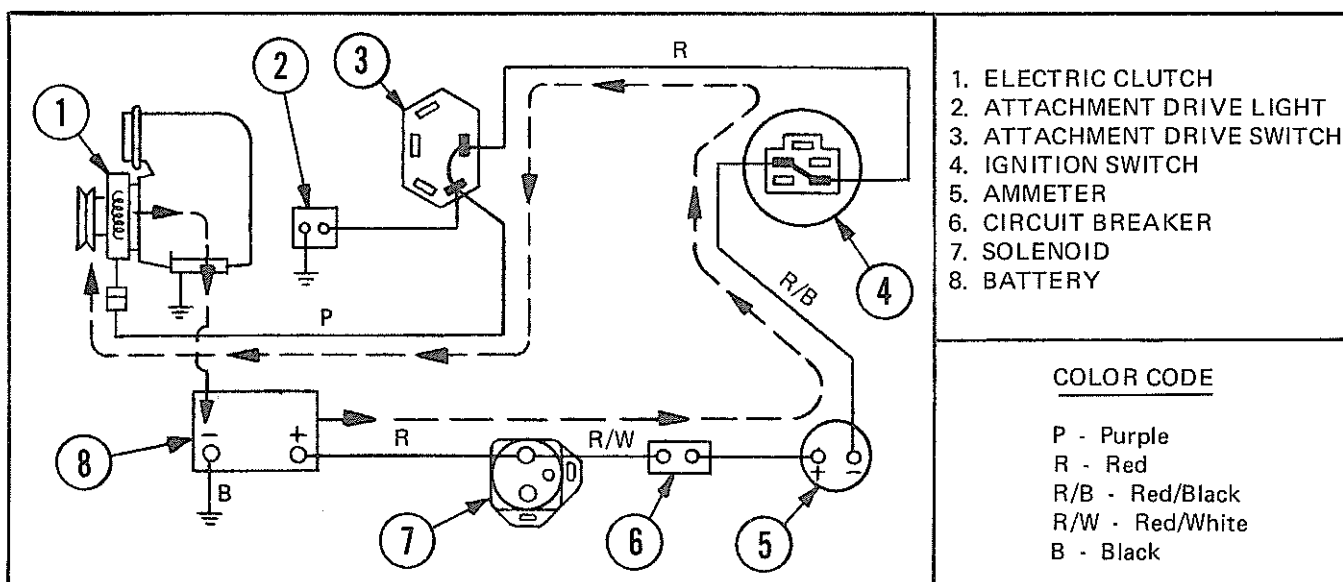

1. ELECTRIC CLUTCH
2. ATTACHMENT DRIVE LIGHT
3. ATTACHMENT DRIVE SWITCH
4. IGNITION SWITCH
5. AMMETER
6. CIRCUIT BREAKER
7. SOLENOID
8. BATTERY

COLOR CODE

- P - Purple
- R - Red
- R/B - Red/Black
- R/W - Red/White
- B - Black

CIRCUIT DIAGRAM

1058, 1060 AND 1160 S/N 0100101 AND UP

SEAT SWITCH CIRCUIT
(Attachment switch in ON)

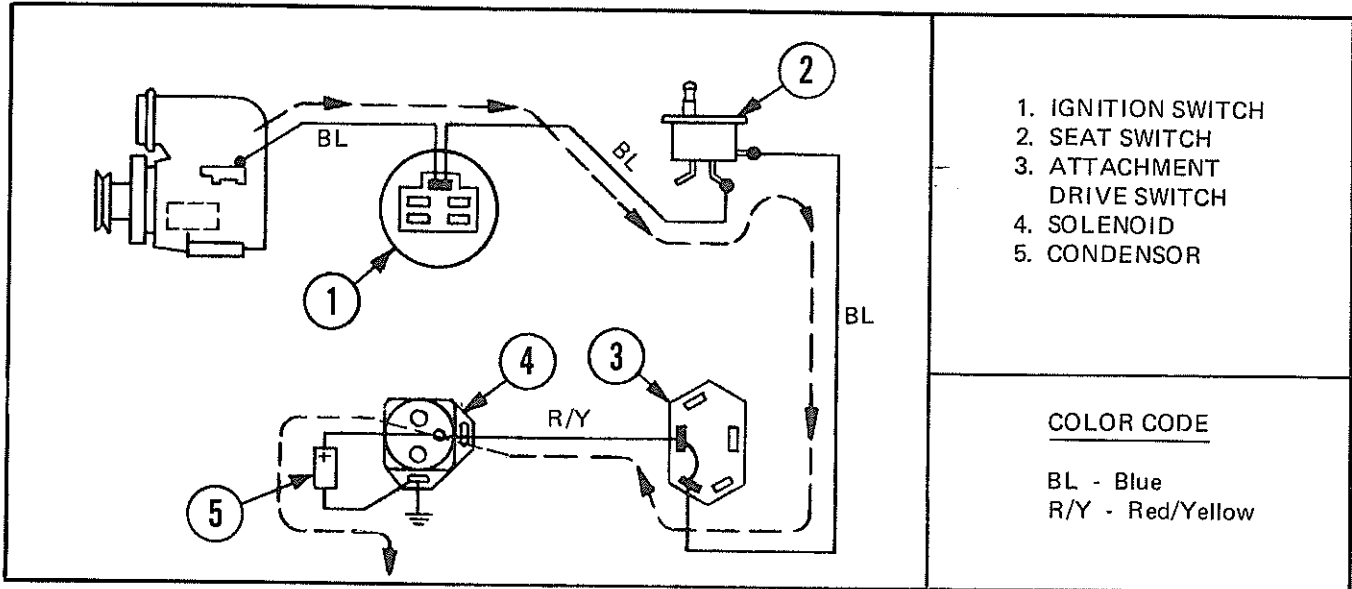

COMPLETE WIRING DIAGRAM

1258, 1261, 1458, 1461, 1658, 1661, 1663, 1664 AND 1858

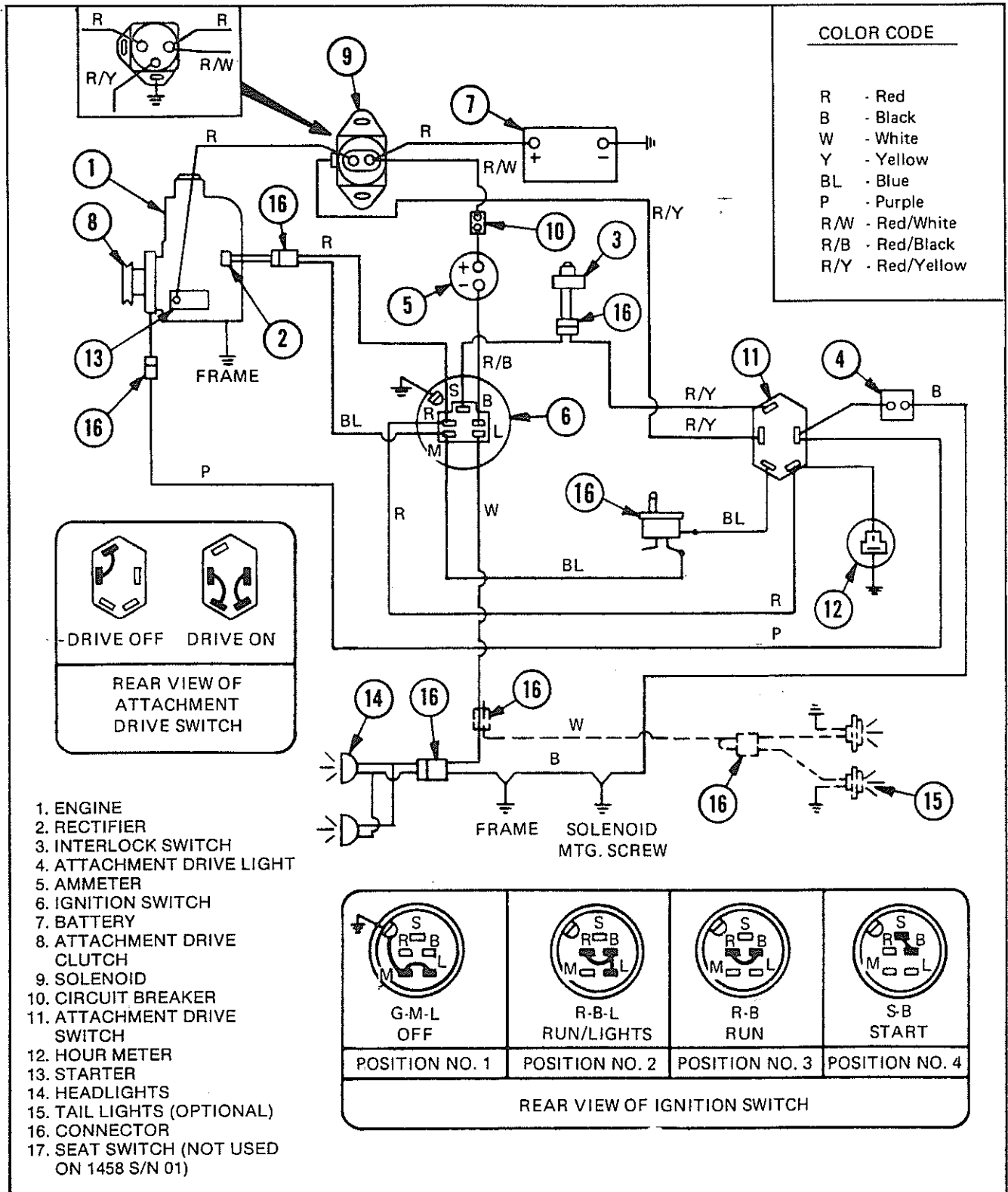

CIRCUIT DIAGRAM

1258, 1261, 1458, 1461, 1463, 1658, 1661, 1663, 1664 AND 1858 S/N 0100101 AND UP

LIGHT CIRCUIT

(Ignition switch in "RUN/LIGHTS" position)

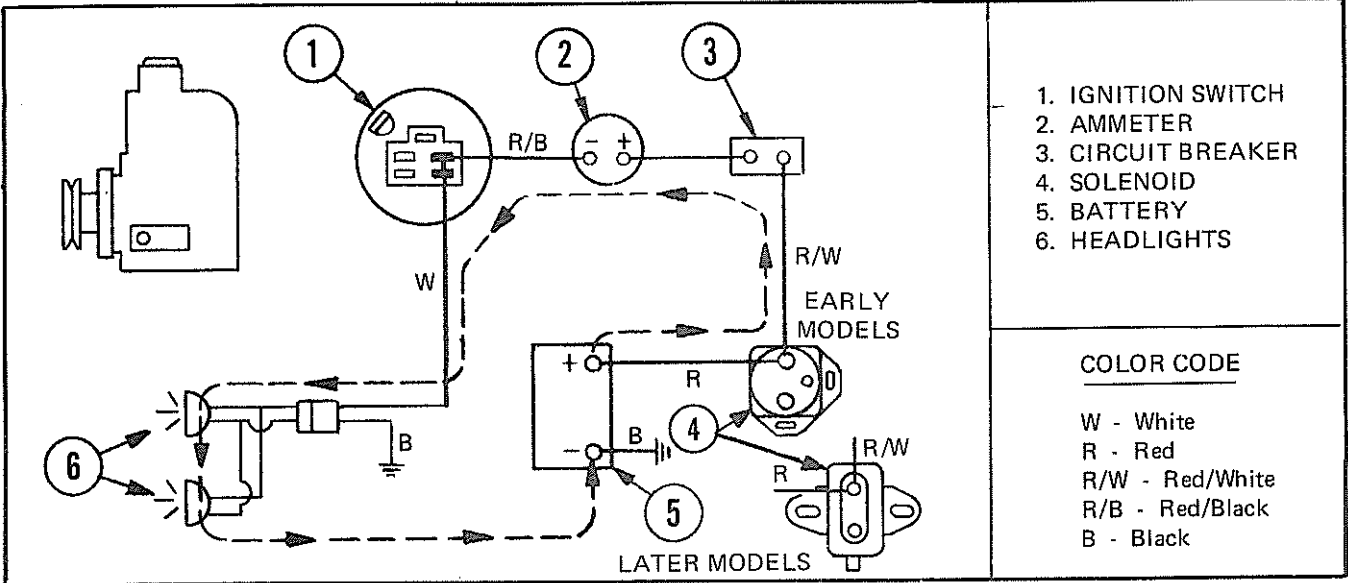

CHARGING CIRCUIT

(Ignition switch in "RUN/LIGHTS" or "RUN" position)

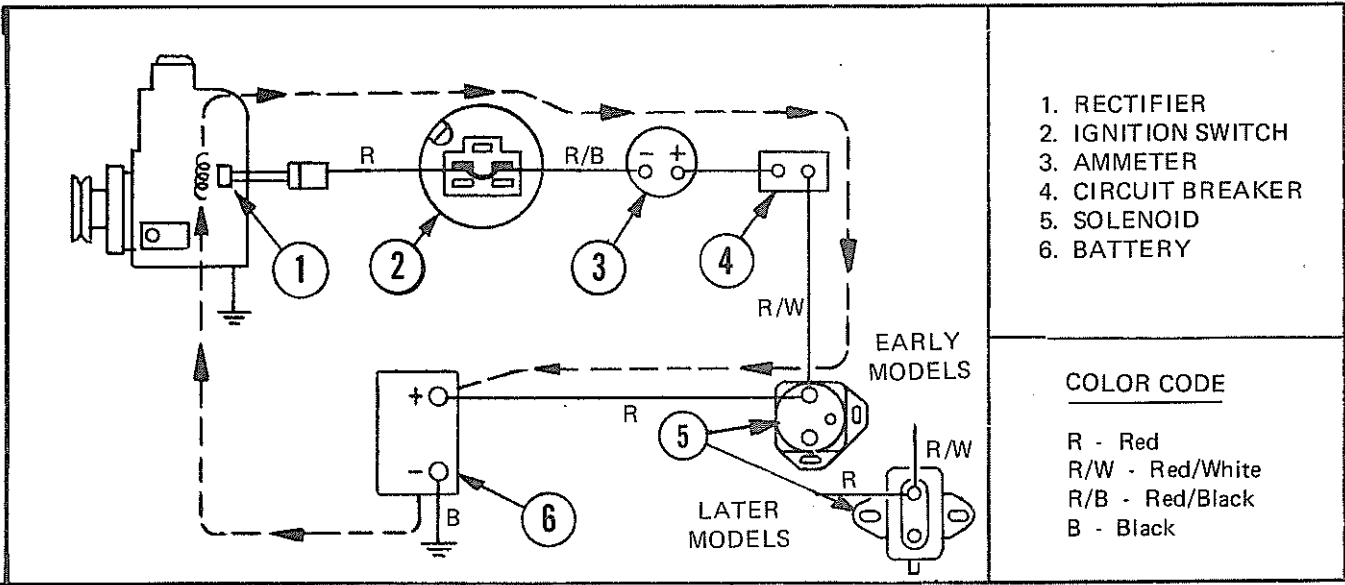

CIRCUIT DIAGRAM

1258, 1261 S/N 0100101-0199999 1458, 1461, 1658 S/N 0100101 AND LATER
1661 S/N 0100101-0299999 1858 S/N 0100101-0199999

STARTING CIRCUIT

(Ignition switch in "START" position, Brake switch depressed and Attachment switch OFF)

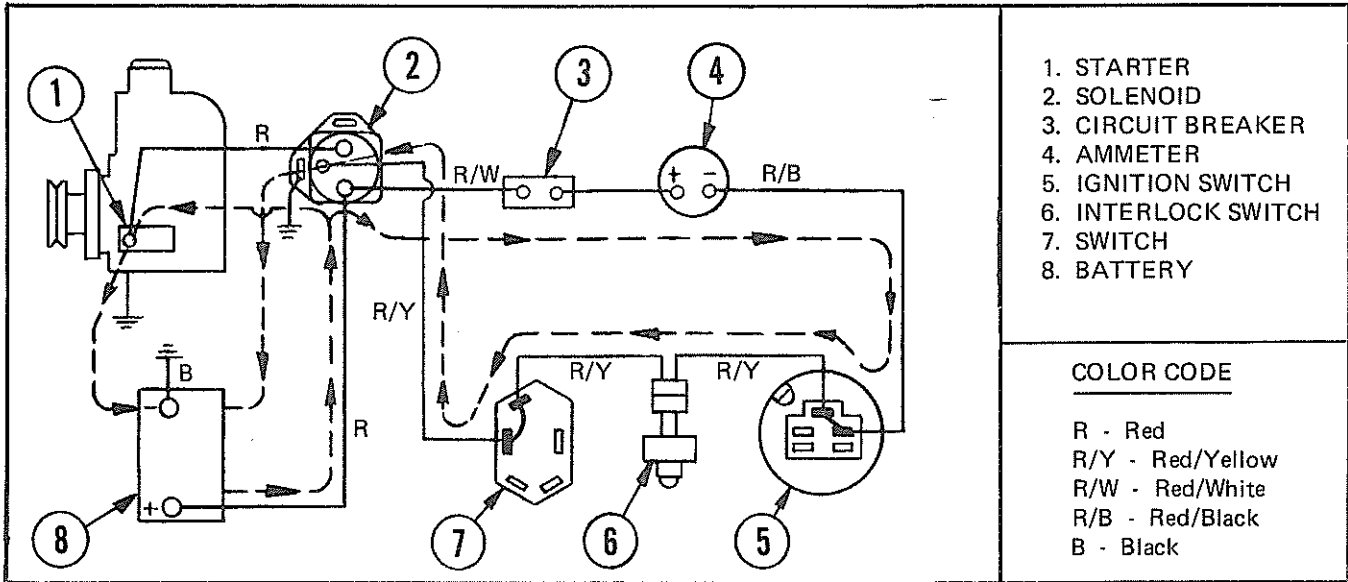

2

1258, 1261, 1858 S/N 0200101 AND LATER - 1463, 1663, 1664 S/N 0100101 AND LATER - 1661 S/N 0300101 AND LATER

STARTING CIRCUIT

(Ignition switch in "START" position, brake switch depressed and attachment switch OFF)

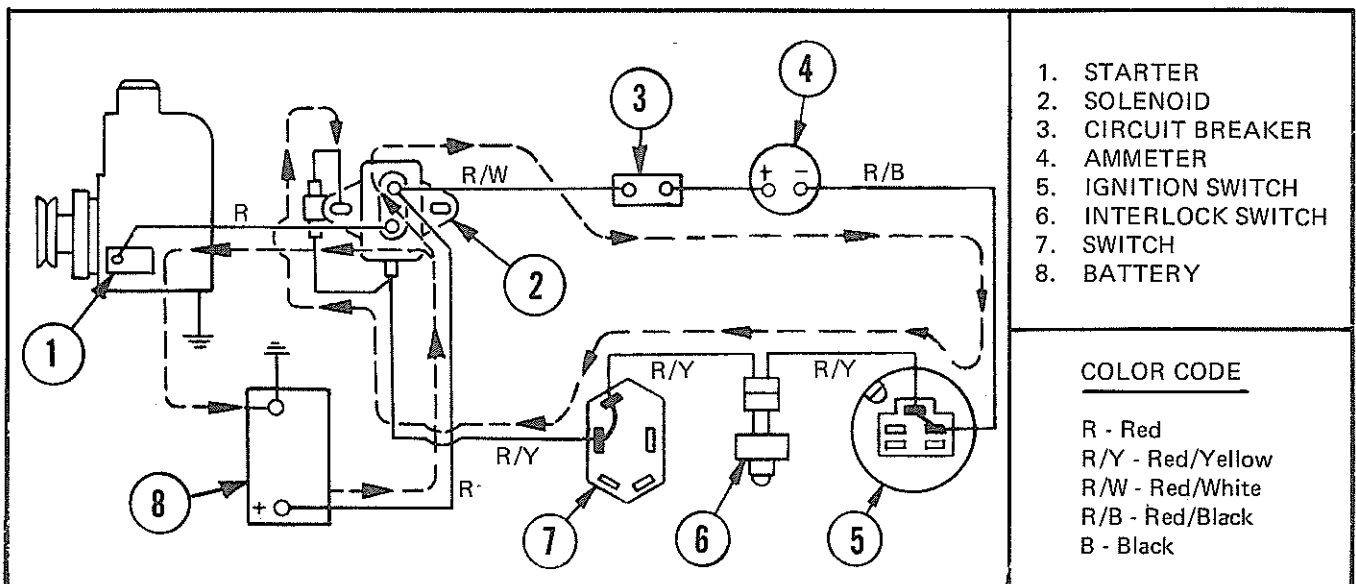

ELECTRICAL SYSTEM (Continued)

CIRCUIT DIAGRAM

1258, 1261, 1458, 1461, 1463, 1658, 1661, 1663, 1664 AND 1858 S/N 0100101 AND UP

SEAT SWITCH CIRCUIT

(Attachment switch ON)

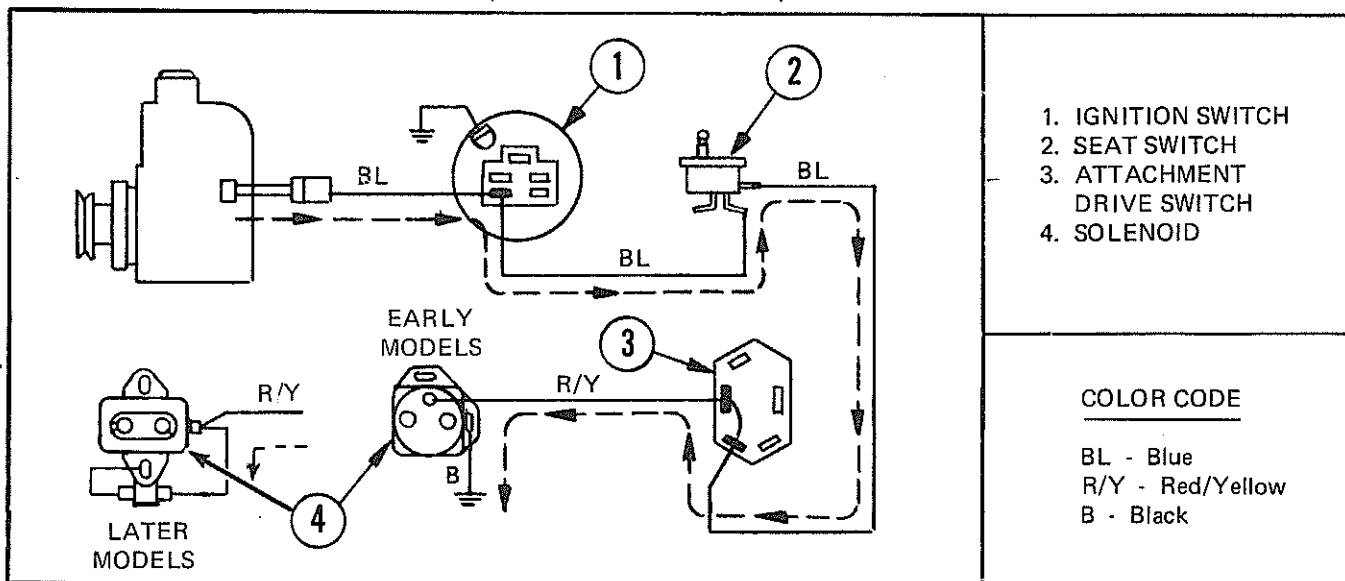

ATTACHMENT DRIVE CIRCUIT

(Ignition switch in "RUN/LIGHTS" or "RUN" position and Attachment switch ON)

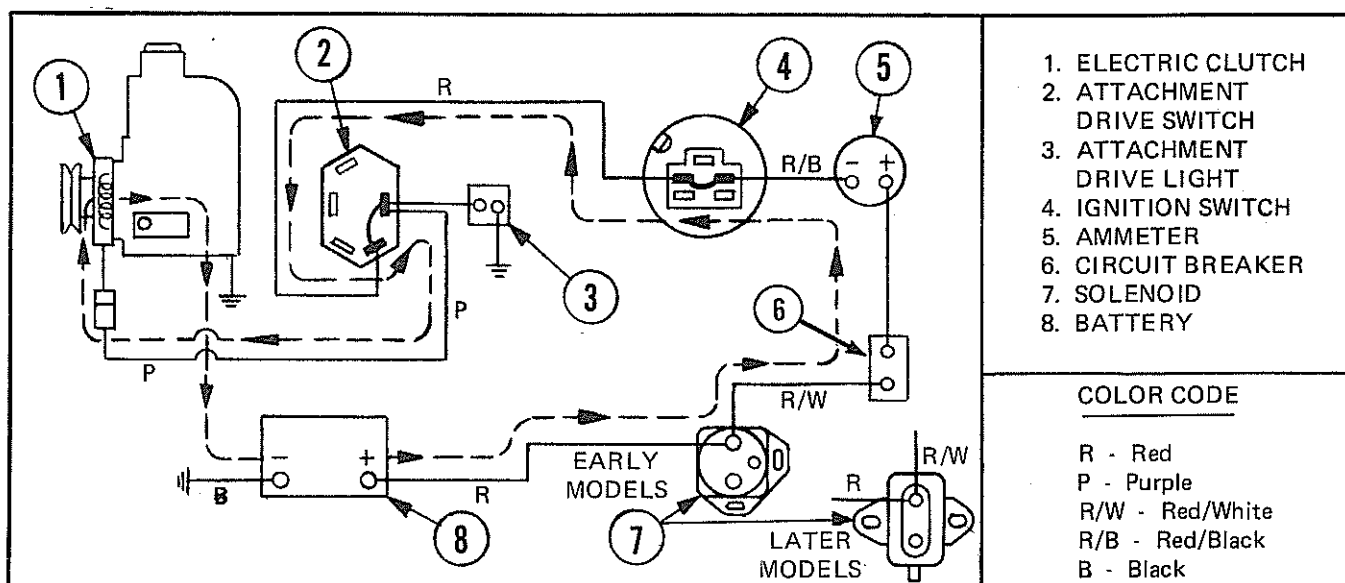

ELECTRICAL SYSTEM (Continued)

MEDIUM FRAME
SERIES TRACTOR
Page 2-13 Rev. 4/90

1659, 1662 S/N 0100101 AND UP

COLOR CODE

R - Red
B - Black
W - White
Y - Yellow
BL - Blue
P - Purple
R/W - Red/White
R/B - Red/Black
R/Y - Red/Yellow

2

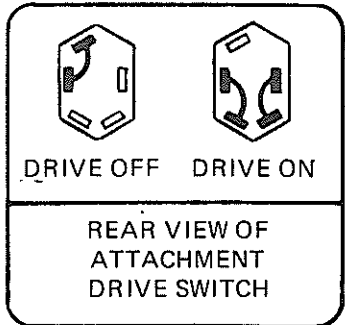
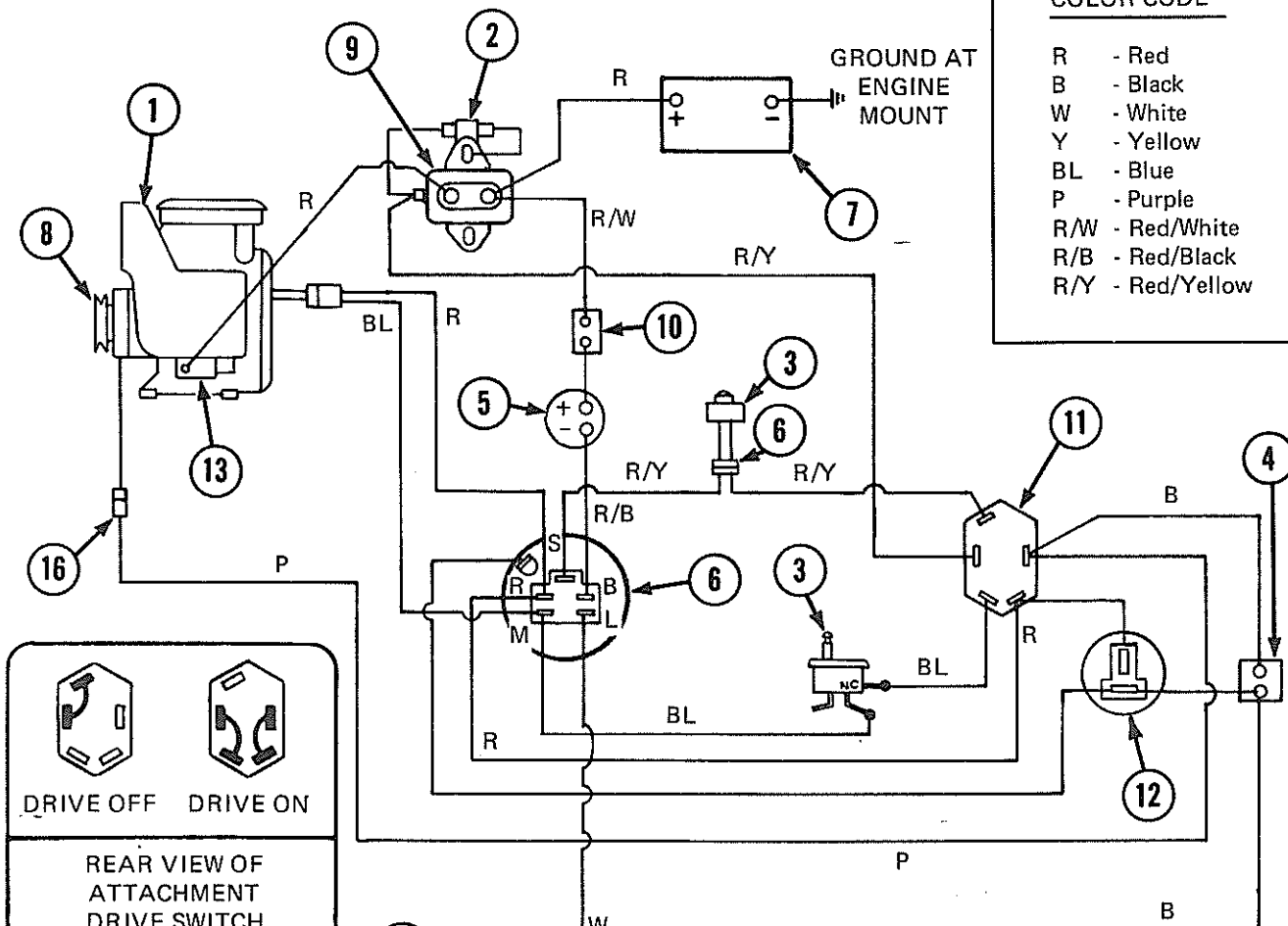

1. ENGINE
2. CAPACITOR
3. INTERLOCK SWITCHES
4. ATTACHMENT DRIVE LIGHT
5. AMMETER
6. IGNITION SWITCH
7. BATTERY
8. ATTACHMENT DRIVE CLUTCH
9. SOLENOID
10. CIRCUIT BREAKER
11. ATTACHMENT DRIVE SWITCH
12. HOUR METER
13. STARTER
14. HEADLIGHTS
15. TAIL LIGHTS (OPTIONAL)
16. CONNECTORS

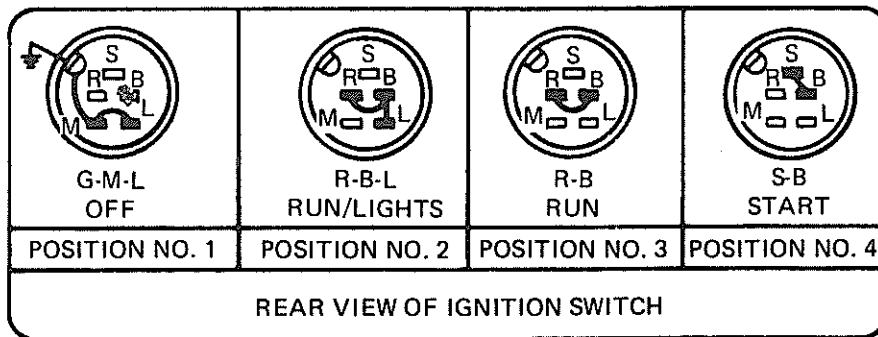
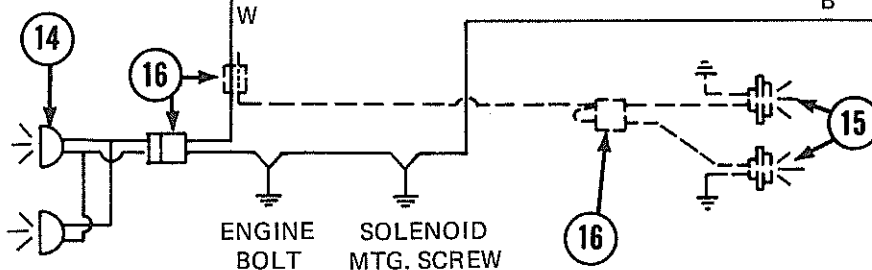

ELECTRICAL SYSTEM (Continued)

COMPLETE WIRING DIAGRAM

MODELS 1667 S/N 0100101 thru 0399999
 1668 S/N 0100101 thru 0399999

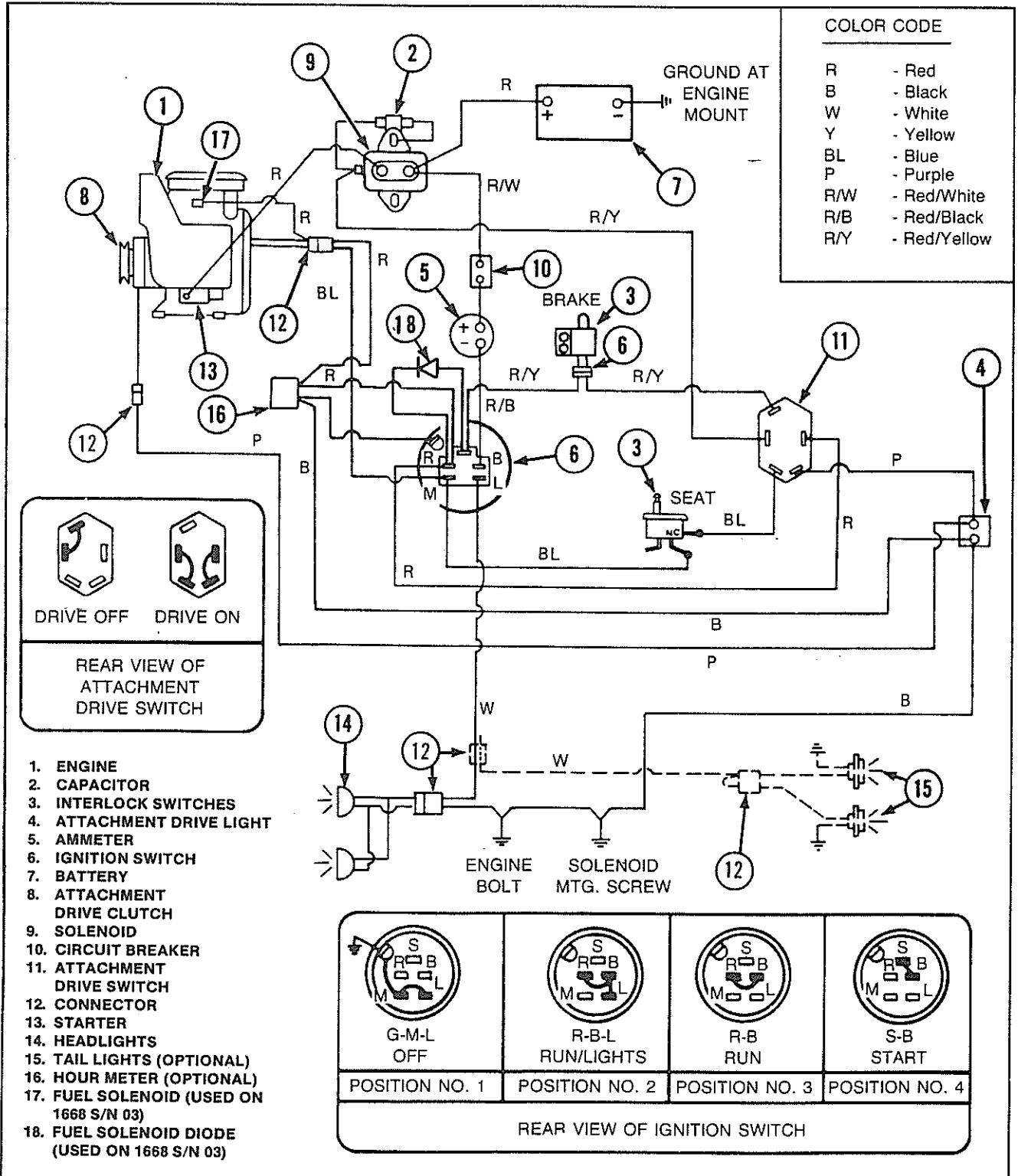

COMPLETE WIRING DIAGRAM

MODEL 1467 AND 1668 S/N 0400101 thru 0599999

1668L S/N 0100101 thru 0199999

1667 S/N 0400101 thru 0499999

COLOR CODE

R	- Red	P	- Purple
B	- Black	R/W	- Red/White
W	- White	R/B	- Red/Black
Y	- Yellow	R/Y	- Red/Yellow
BL	- Blue		

2

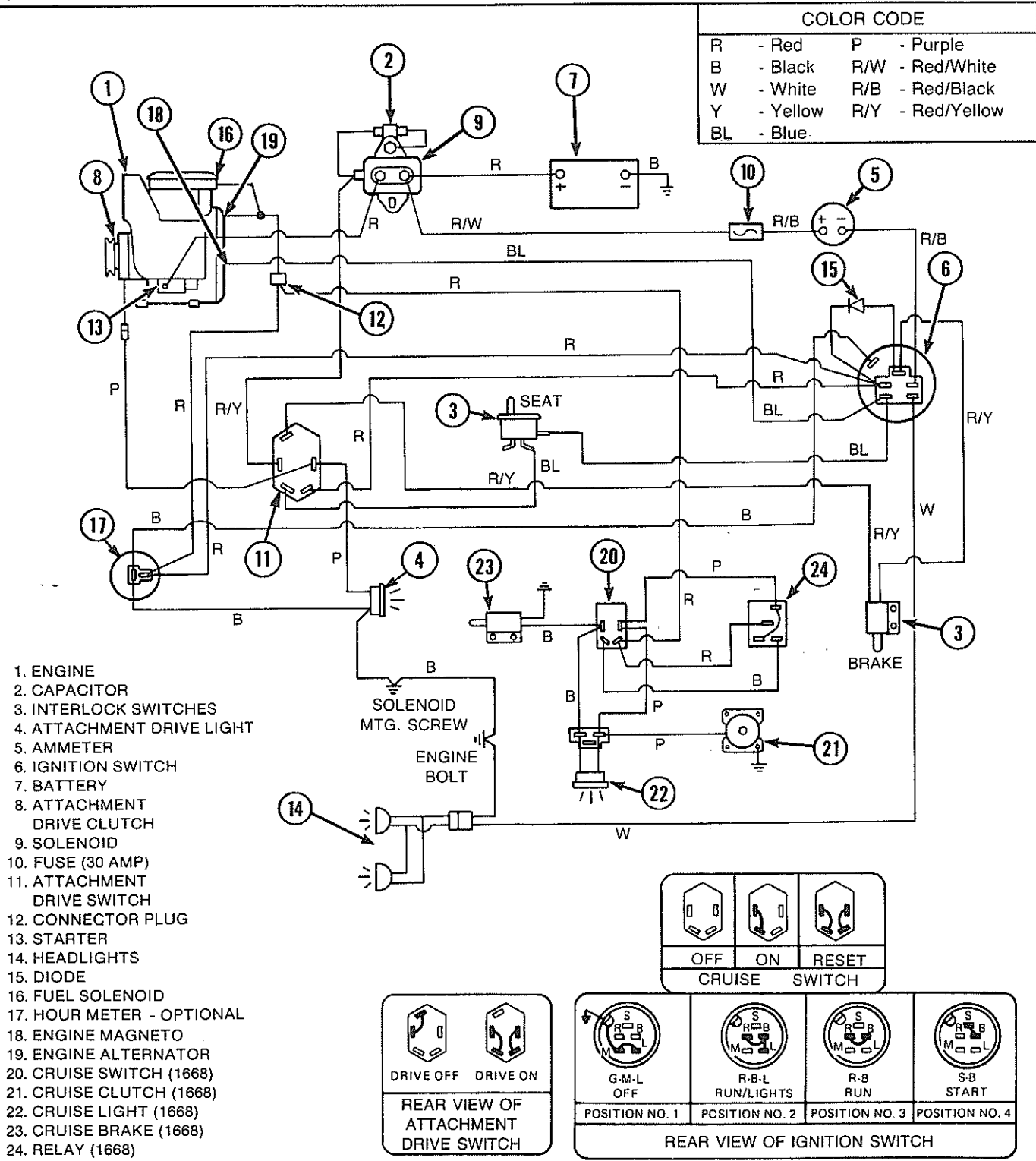

COMPLETE WIRING DIAGRAM

MODEL 1669 AND 1669L

1. ENGINE
3. INTERLOCK SWITCHES
4. ATTACHMENT DRIVE LIGHT
5. AMMETER
6. IGNITION SWITCH
7. BATTERY
8. ATTACHMENT DRIVE CLUTCH
9. SOLENOID
10. FUSE (30 AMP)
11. ATTACHMENT DRIVE SWITCH
12. CONNECTOR PLUG
13. STARTER
14. HEADLIGHTS
15. DIODE
16. FUEL SOLENOID
17. HOUR METER - OPTIONAL
18. ENGINE MAGNETO
19. ENGINE ALTERNATOR
20. CRUISE SWITCH
21. CRUISE MAGNET
22. CRUISE LIGHT
23. CRUISE BRAKE
24. RELAY

COLOR CODE

R - Red	P - Purple
B - Black	B/Y - Black/Yellow
W - White	R/B - Red/Black
Y - Yellow	R/Y - Red/Yellow
BL - Blue	G - Green

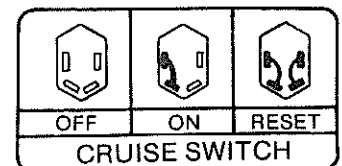
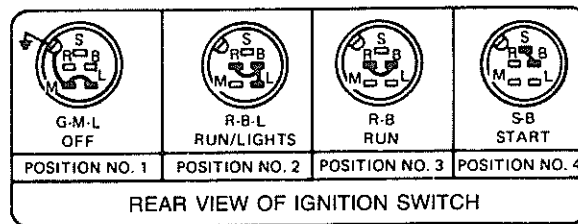
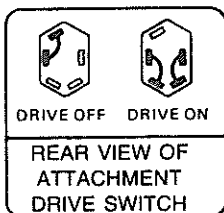
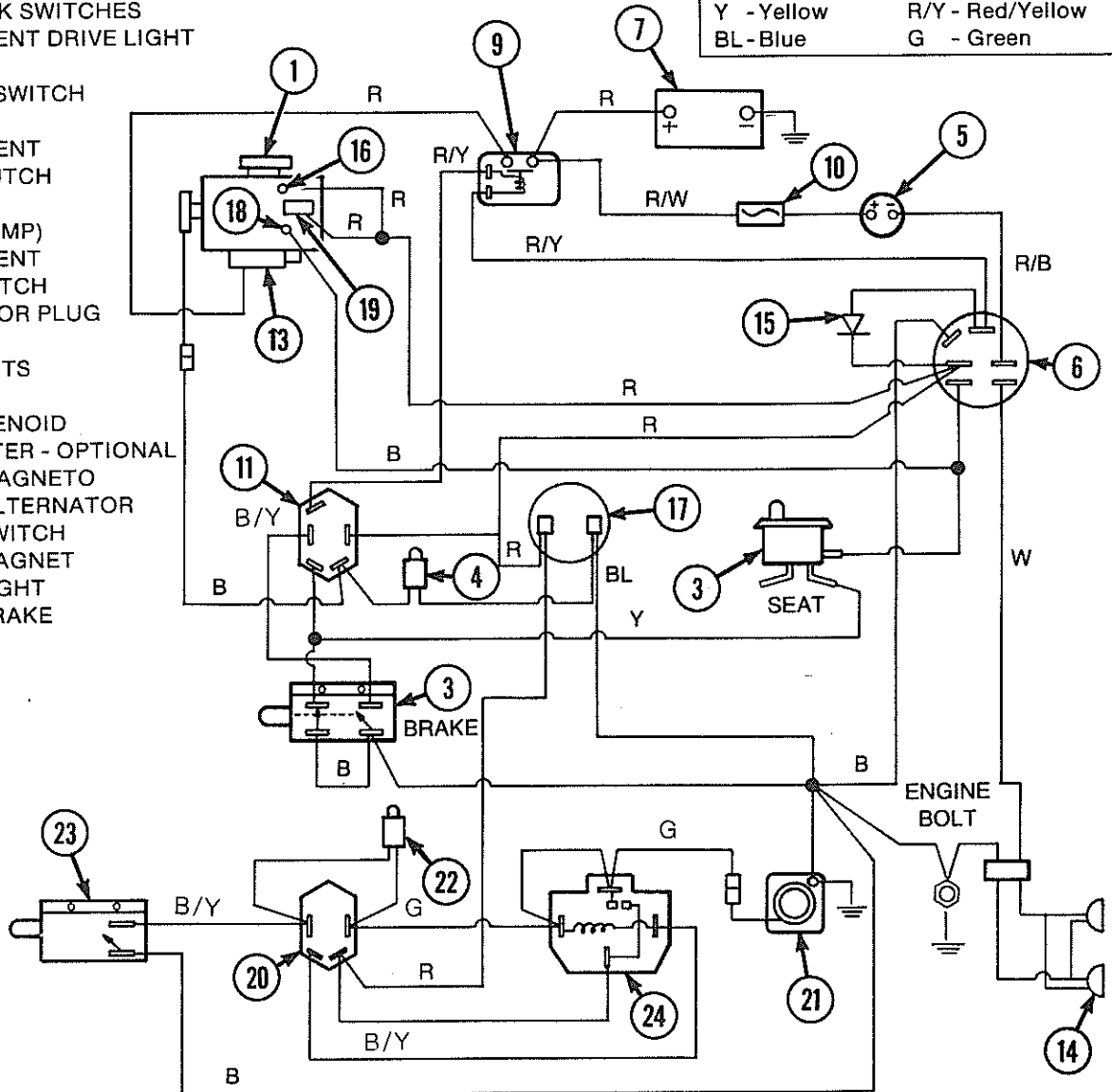

COMPLETE WIRING DIAGRAM MODEL 1468

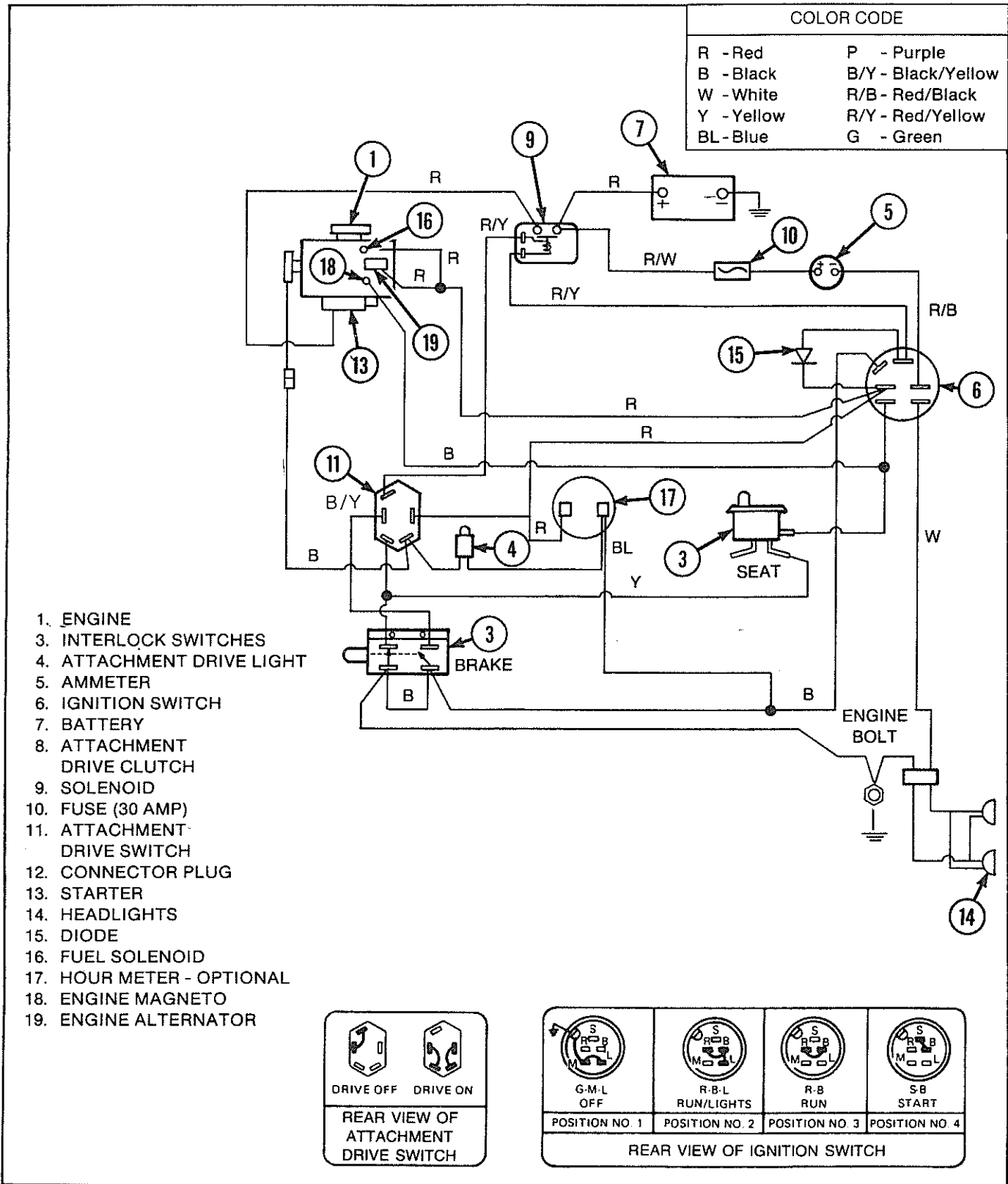

ELECTRICAL SYSTEM (Continued)

CIRCUIT DIAGRAM

1467, 1468, 1659, 1662, 1667, 1668, 1668L, 1669, 1669L S/N 0100101 AND UP

LIGHT CIRCUIT

(Ignition switch in "RUN/LIGHTS" position)

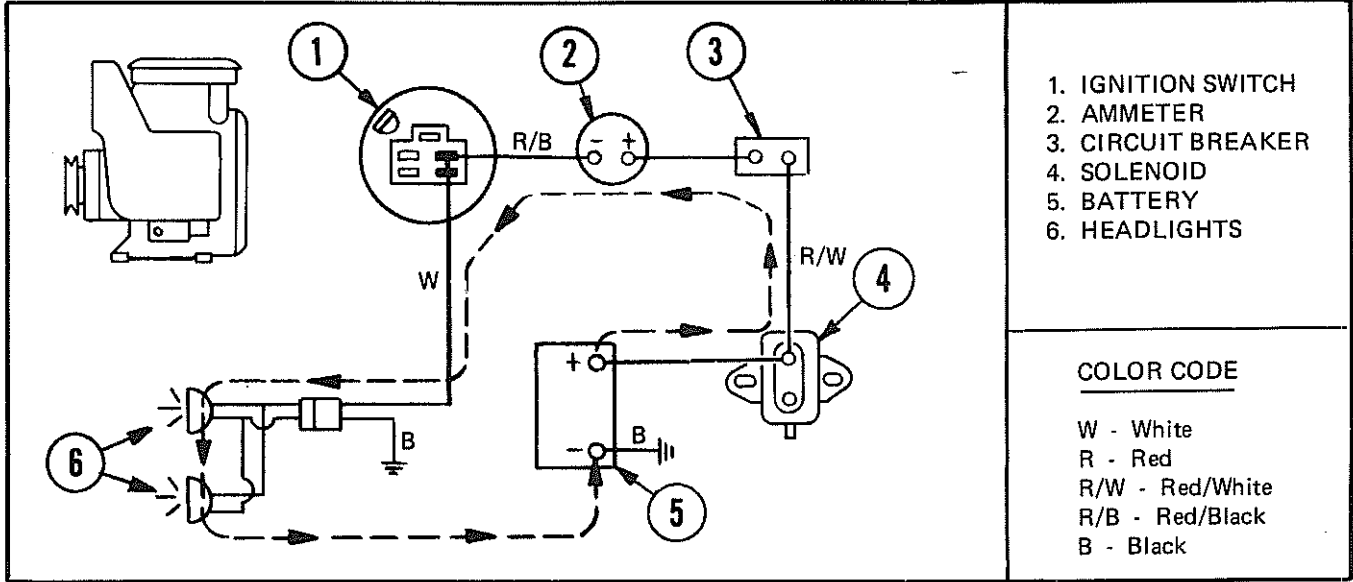

STARTING CIRCUIT

(Ignition switch in "START" position, Brake switch depressed and Attachment switch OFF)

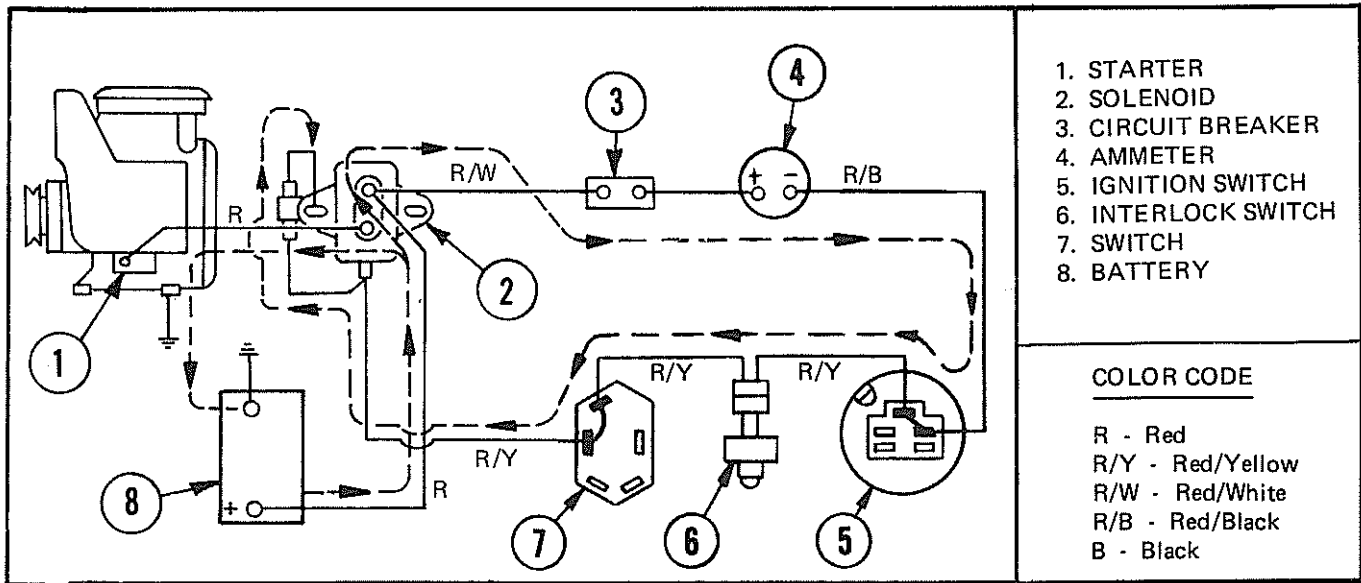

CIRCUIT DIAGRAM

1467, 1468, 1659, 1662, 1667, 1668, 1669, 1669L S/N 0100101 AND UP
CHARGING CIRCUIT

(Ignition switch in "RUN/LIGHTS" or "RUN" position)

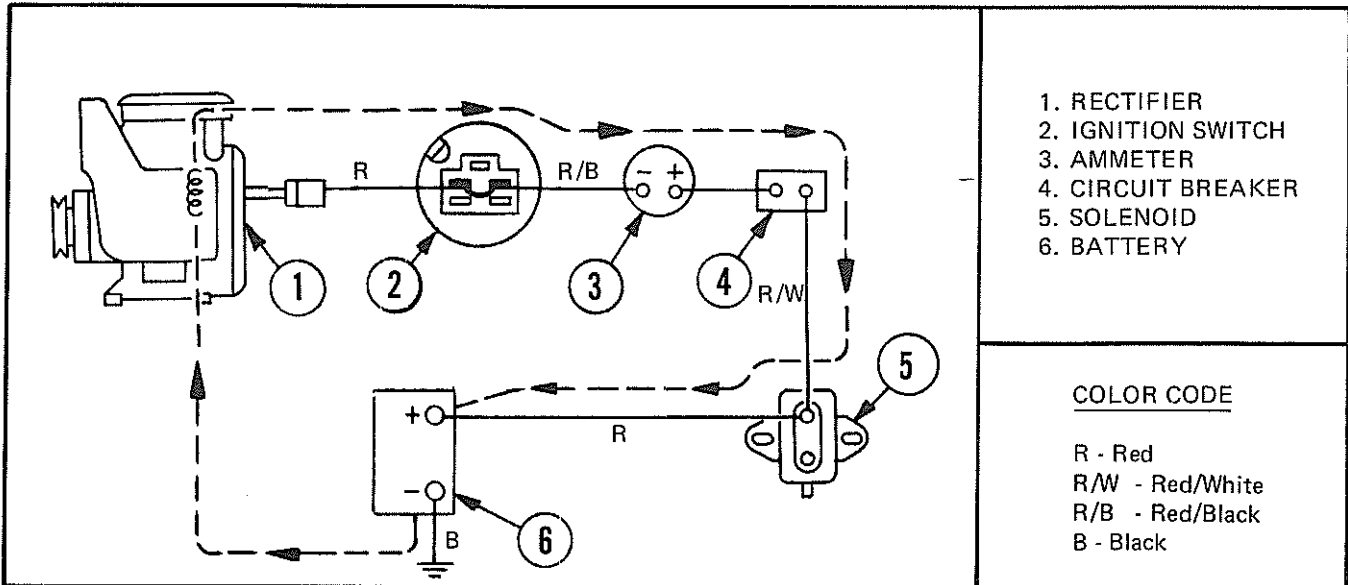

2

ATTACHMENT DRIVE CIRCUIT

(Ignition switch in "RUN/LIGHTS" or "RUN" position and Attachment switch ON)

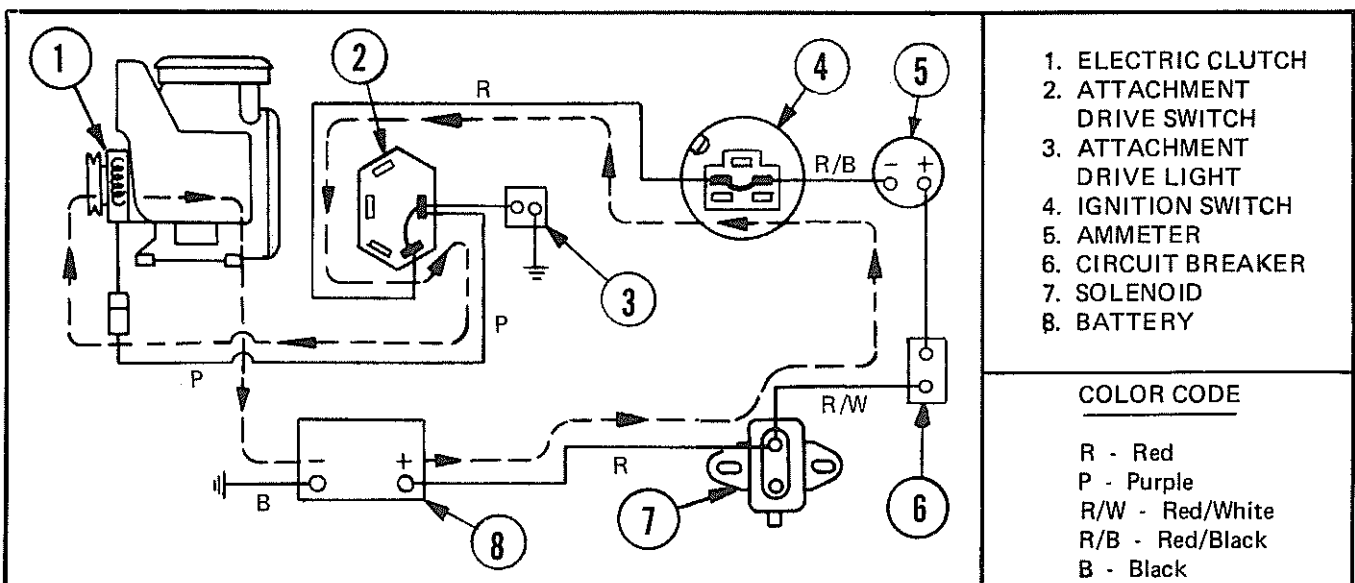

ELECTRICAL SYSTEM (Continued)

CIRCUIT DIAGRAM

1467, 1468, 1659, 1662, 1667, 1668, 1669, 1669L S/N 0100101 AND UP

SEAT SWITCH CIRCUIT (Attachment switch ON)

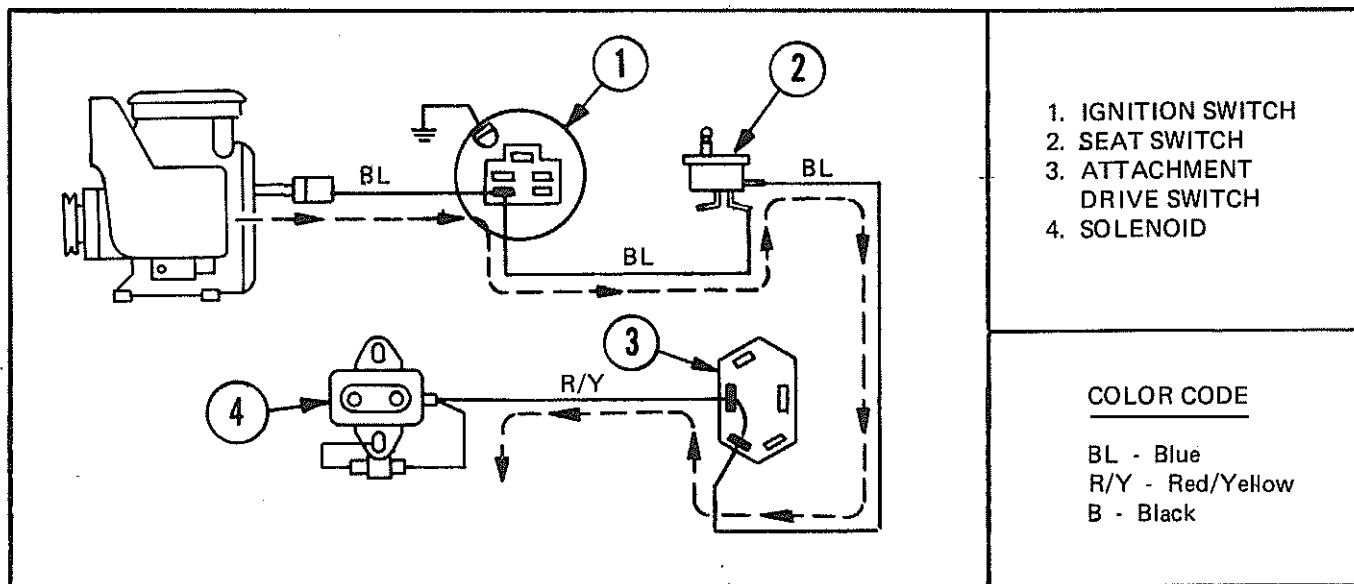

ELECTRIC LIFT

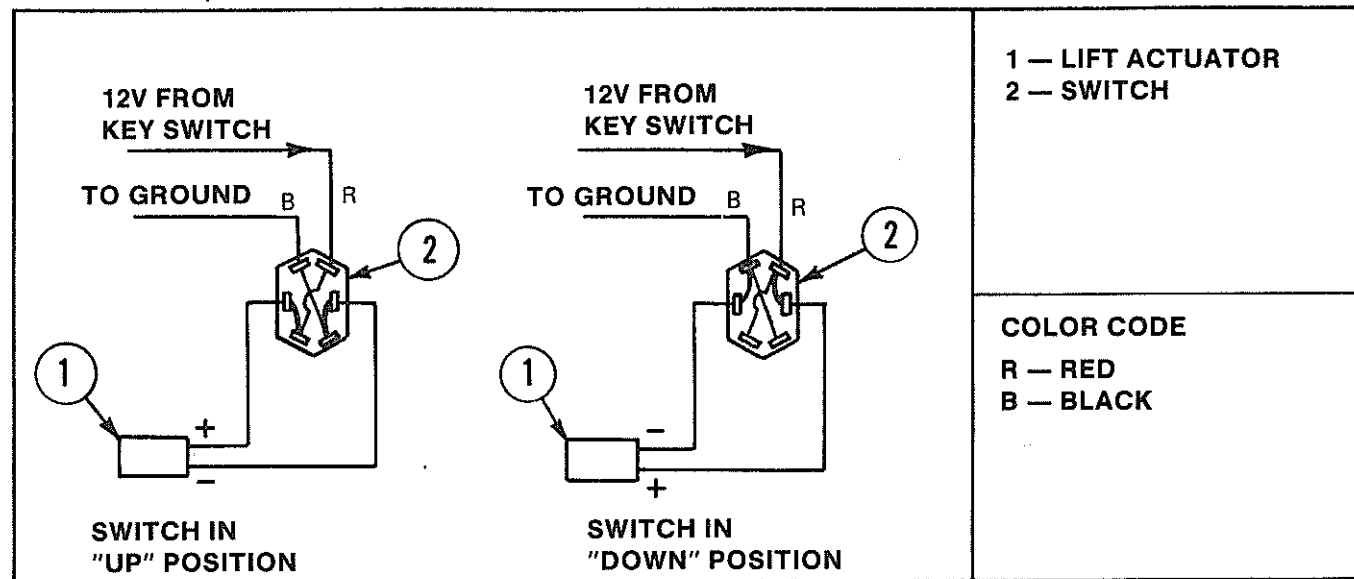

**CIRCUIT DIAGRAMS
ELECTRIC CRUISE CIRCUIT
WITH RELAY IN "RESET" POSITION**

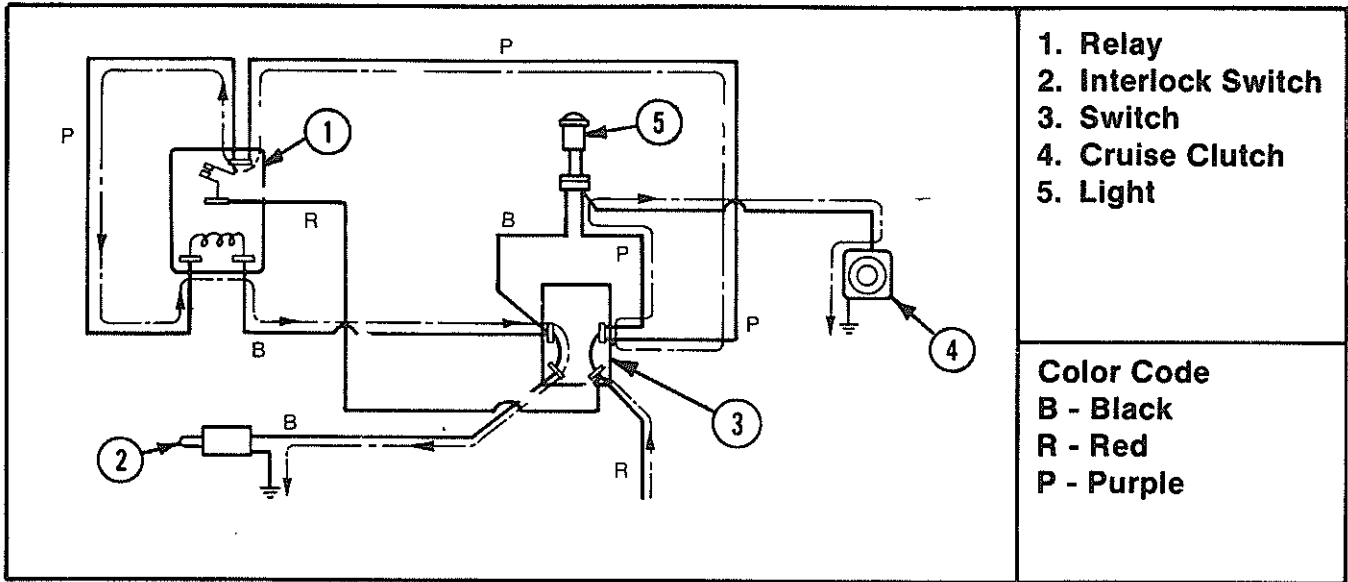

2

**ELECTRIC CRUISE CIRCUIT
WITH RELAY IN "ON" POSITION (AFTER RESET)**

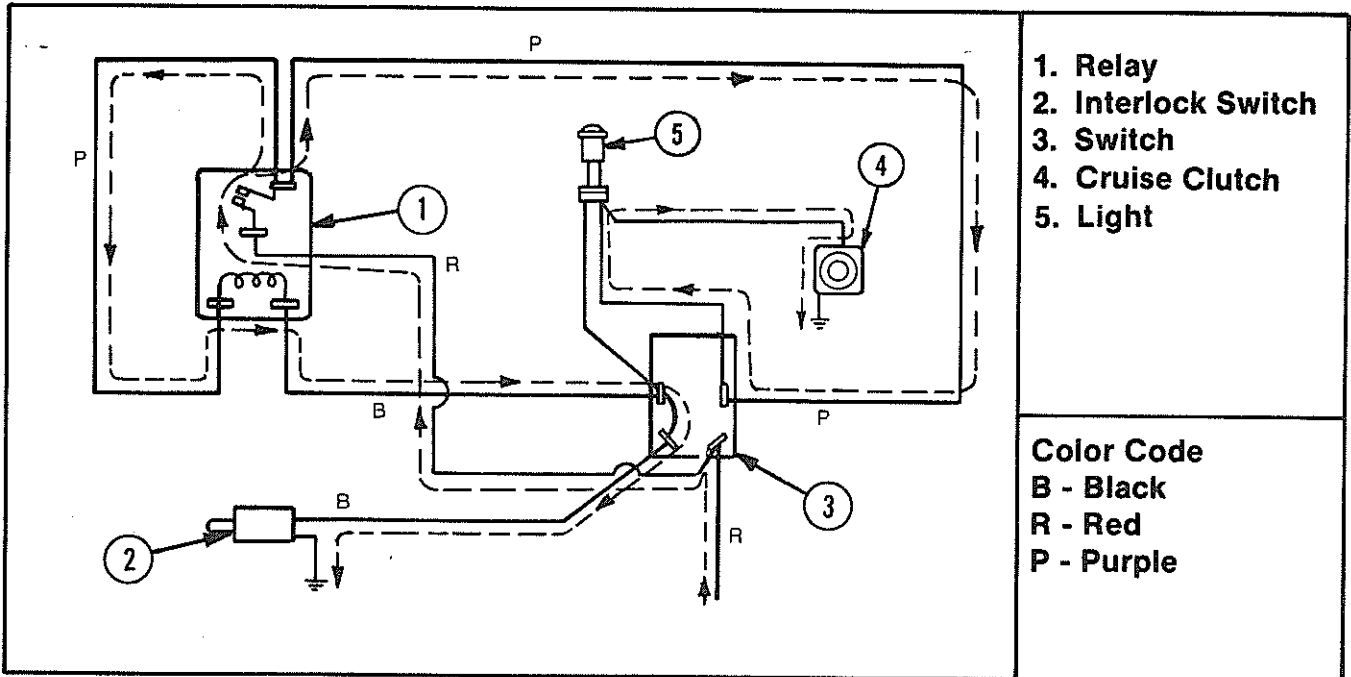

TESTING ELECTRICAL SYSTEM

TESTING BATTERY

CHECKING SPECIFIC GRAVITY

To determine whether the battery is capable of meeting the requirements of the starting motor, it is necessary to subject the battery to a load test. The battery must be at least 75% charged for this test. To determine the percentage of charge a hydrometer reading should be taken. The following table illustrates ranges of specific gravity for each cell in various states of charge at 80°F.

SPECIFIC GRAVITY

	%
	CHARGED
1.250 - 1.280.....	100%
1.230 - 1.250.....	75%
1.200 - 1.220.....	50%
1.170 - 1.190.....	25%
1.140 - 1.160.....	10%
1.110 - 1.130.....	DISCHARGED

CHECKING BATTERY VOLTAGE

Battery voltage can be checked with a volt-ohm meter. It should read between 11.5 and 12.5 volts.

BATTERY CRANKING TEST

For this test the battery should be approximately 80°F.

1. Check battery electrolyte level, add water if necessary. Battery must be fully charged.
2. Check battery voltage. It should be between 11.5 and 12.5 volts.
3. Crank the engine using the starter motor for 15 seconds. Battery voltage should not drop below 9.0 volts at the end of this 15 second test.

4. If voltage is less than 9.0 volts, repeat steps 1 through 4. If same results are obtained, replace battery.

SOLENOID TEST

The solenoid is a sealed unit and must be replaced if found inoperative.

To test the solenoid, connect 9 - 12 volt power source between the solenoid case and the small solenoid terminal.

CAUTION: If the battery is the power source, a spark at the battery post may ignite battery gases.

When the power source is connected the solenoid plunger should activate contact between the two large terminals. If the test does not activate the plunger, replace the solenoid.

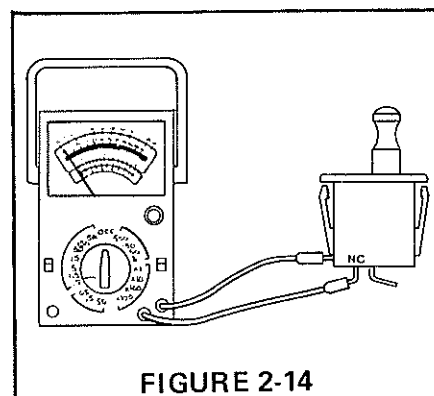

FIGURE 2-14

BRAKE SWITCH (Figure 2-15)

The brake switch is wired "Normally Open" (NO).

To test, connect an ohm meter and depress the switch plunger. Meter should indicate zero resistance.

At "Normally Open" (NO) position, the meter should indicate an infinite reading.

SWITCH TESTS

Before the electrical test of any switch, make sure the mechanical adjustments of its actuating mechanisms are correct.

SEAT SWITCH

The seat switch is wired "Normally Closed" (NC).

To test, connect an ohm meter as shown in Figure 2-14 and depress plunger. Meter should indicate zero resistance. At the "Normally Open" position, the meter should indicate an infinite reading.

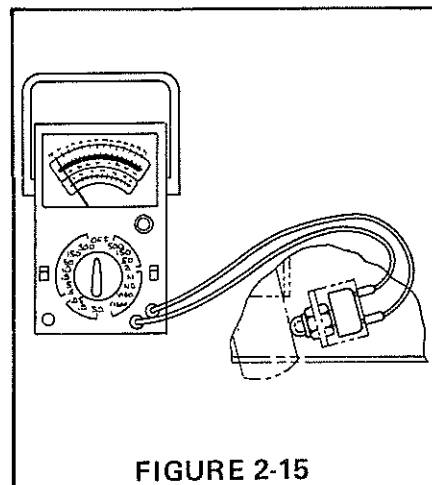

FIGURE 2-15

TESTING ELECTRICAL SYSTEM

ATTACHMENT DRIVE SWITCH

When switch is in down (OFF) position, check continuity between the middle terminal and top terminal on same side. See Figure 2-16. Resistance should be zero.

When switch is in top (ON) position, check continuity between the two middle terminals and bottom terminals on same side. See Figure 2-16. Resistance should be zero.

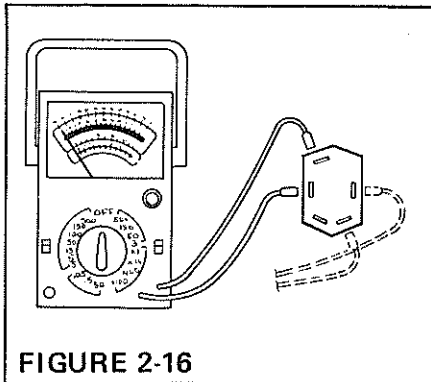

FIGURE 2-16

DIODE TEST (BRIGGS AND STRATTON ENGINES ONLY) FIGURE 2-17

A continuity light or ohm meter can be used to check the diode. If a continuity light is used, connect it across the diode and note whether the light comes on; then reverse leads. The light should be on in one direction, but not the other, when the leads are reversed.

If an ohm meter is used, measure the resistance, then reverse the leads and remeasure. A comparison of the two readings should indicate 10:1 resistance ratio should be measured.

TESTING IGNITION SWITCH

Test the ignition switch for proper internal connections using an

ohm meter or continuity light. Terminals should be closed only in the positions indicated in Figure 2-18 and 2-19.

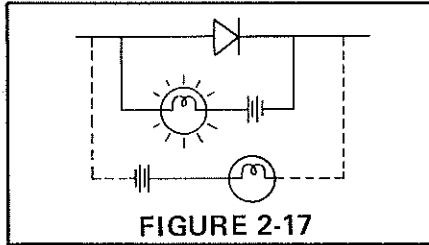
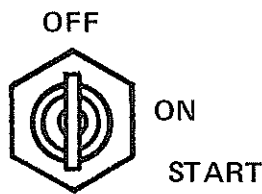
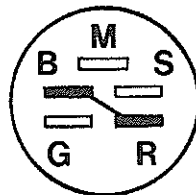

FIGURE 2-17

MODEL 1058, 1060 AND 1160



"OFF" POSITION



"ON" POSITION

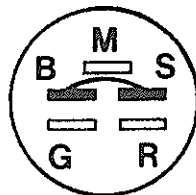

"START" POSITION
FIGURE 2-18

MODEL 1258, 1261, 1458, 1461, 1463, 1467, 1468, 1658, 1659, 1662, 1663, 1664, 1667, 1668, 1668L, 1669, 1669L AND 1858

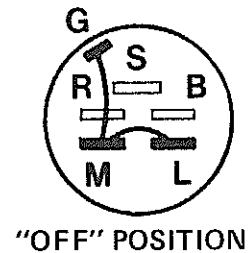
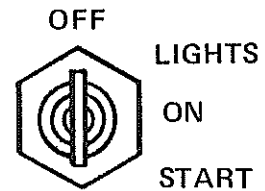

"OFF" POSITION

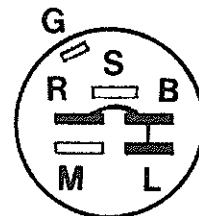

"LIGHTS" POSITION

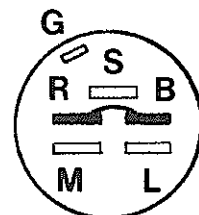

"ON" POSITION



"START" POSITION
FIGURE 2-19

TROUBLE SHOOTING GUIDE

3

PROBLEM	PROBABLE CAUSE	REMEDY
<p>No forward or reverse with engine running.</p> <p>(gear models)</p> <p>(hydro models)</p>	<ol style="list-style-type: none"> 1. Broken drive belt. 2. Drive belt off gear box or transmission drive line 3. Drive idler spring broken. 4. Clutch not functioning properly. 5. Transmission not functioning. 6. System low on oil. 7. Plugged oil filter. 8. Control linkage binding. 9. Hydro unit not functioning. 	<ol style="list-style-type: none"> 1. Replace belt. 2. Reinstall belt. Replace belt if badly worn. Check belt guides. 3. Replace spring. 4. Check and adjust linkage. 5. Repair transmission. 6. Refill to proper level. 7. Replace filter. 8. Check linkage, correct problem. 9. Repair hydro. Refer to Eaton Model II Repair Manual.
<p>Loss of power.</p> <p>(hydro models)</p>	<ol style="list-style-type: none"> 1. Filter or suction line clogged. 2. Low on oil. 3. Worn or loose hydro linkage. 4. Air in system. 5. Engine slows down or is sluggish. 	<ol style="list-style-type: none"> 1. Replace filter, clean and refill system with fresh oil. 2. Check and add as necessary. 3. Adjust or replace. 4. Check hydraulic line connections. 5. Check engine for proper RPM. Set at 3600 RPM (no load) using a tachometer. See Engine Section.
<p>Unit operating hot.</p> <p>(hydro models)</p>	<ol style="list-style-type: none"> 1. Oil level low. 2. Low engine RPM 3. Dirt on transmission fins. 4. Excessive load or high drawbar loading. 5. Partially plugged filter. 6. Internal damage to hydro. 	<ol style="list-style-type: none"> 1. Check for leaks and refill to proper level. 2. Operate at full throttle. 3. Clean external surface. 4. Reduce load. 5. Replace filter and oil. 6. Repair hydro. Refer to Eaton Model II Repair Manual.
<p>Brake does not function properly.</p>	<ol style="list-style-type: none"> 1. Brake pucks or band worn. 2. Brake out of adjustment. 	<ol style="list-style-type: none"> 1. Replace brake pucks or band. 2. Tighten brake adjusting nut as required.

EATON HYDROSTATIC INTRODUCTION & REPAIR

IDENTIFICATION

The Model 11 hydrostatic is a counter clockwise drive, that is used on all Medium Frame Series tractors.

To identify, locate the Serial Number stamped in area on the charge pump.

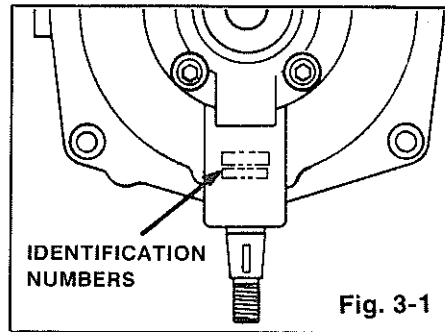

Fig. 3-1

REPAIR

If the hydrostatic transmission is in need of repair, refer to the Eaton Service & Repair Manual. This manual is available from the factory.

The Eaton Model 11 hydrostatic transmission is composed of four (4) major components: a charge pump; a variable displacement, radial ball-piston pump; a fixed displacement, radial ball-piston motor; and a system of valves located between the pump and motor.

The transmission converts mechanical energy at its input shaft into fluid flow under

pressure from its pump. This fluid energy to its motor which in turn converts it back to mechanical energy at its output shaft. The purpose of this transformation is to provide an infinitely variable output speed, with easy reversing, all with a constant input speed.

In operation, the pressure of the fluid in the hydrostatic transmission closed loop varies as the "load" increases or decreases.

If the load increases, so does the pressure of the fluid in the transmission. This change in load and pressure automatically changes the torque output of the transmission. The greater the load (pressure), the more torque the transmission produces to match the load requirements. If the load is decreased, pressure decreases and torque output drops.

HYDROSTATIC TRANSMISSION FLOW CHART

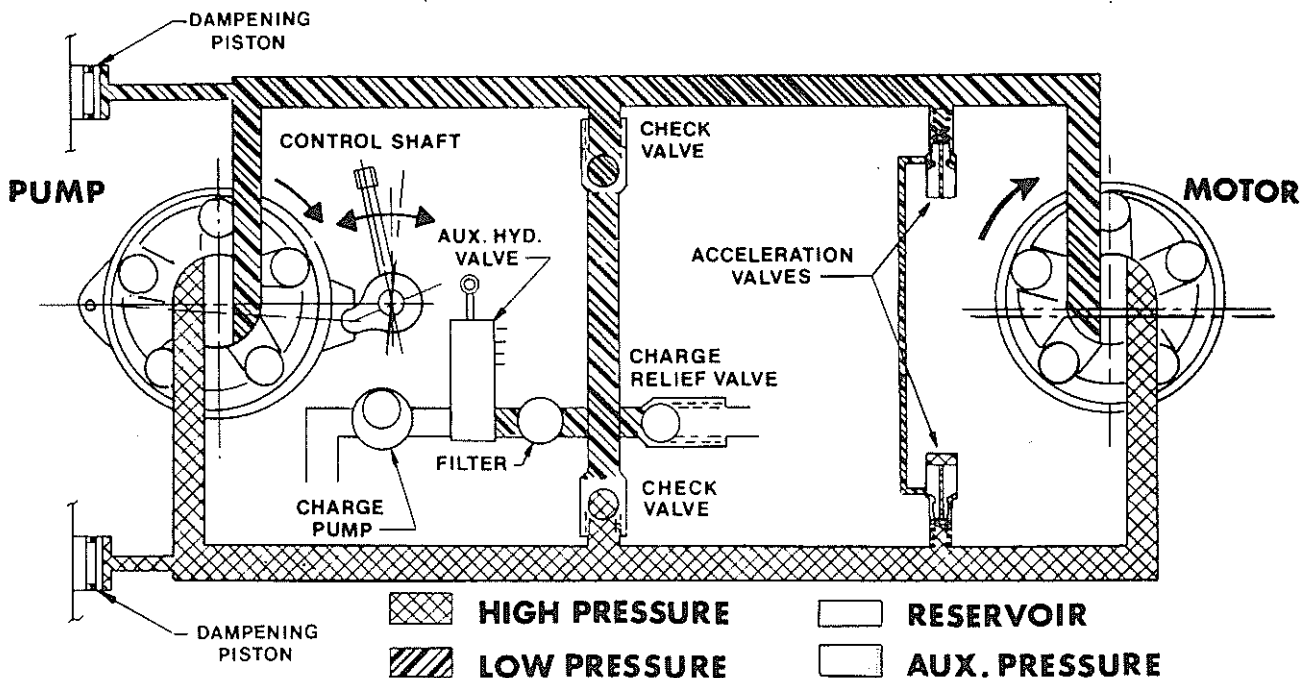

HYDROSTATIC REMOVAL

NOTE: SEE TRANSAXLE REMOVAL page 3-6 before removing hydro. Some models may require removing transaxle before hydrostatic removal. **HYDROSTATIC REMOVAL (Fig. 3-2 & 3-3)**

1. Remove tunnel, seat & fenders.
2. Remove driveshaft from input shaft.
3. Clean any dirt or grease from hydraulic line (A) fittings.
4. Disconnect hydraulic lines (A) from hydro. Have oil pan to catch excess oil.
5. Remove nut and washer on control shaft and slide control arm assembly (B) off shaft.

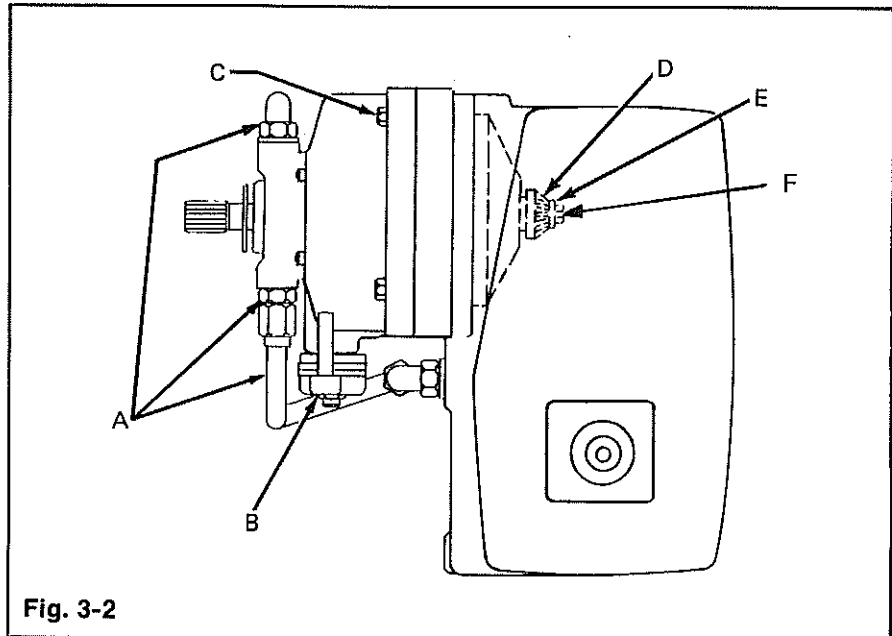

Fig. 3-2

Carefully remove hydro from transaxle.

7. If replacing complete hydro, remove bevel gear (D) & shims

from output shaft. To disassemble, hold spacer (E) in place when loosening bolt (F). Position shims & bevel gear onto new hydrostatic and fasten. Torque bolt with spacer to 24 ft./lbs. (23.5 N-m).

NOTE: A puller may have to be used when removing the control arm.

6. Remove the four (4) mounting cap screws (C) securing the hydrostatic to the transaxle.

HYDROSTATIC REPAIR

If the hydrostatic transmission is in need of repair, refer to the **Eaton Repair Manual**. This manual is available from the factory.

EATON HYDRO TESTING

For testing procedure, refer to **Hydraulic Section, page 6-3**.

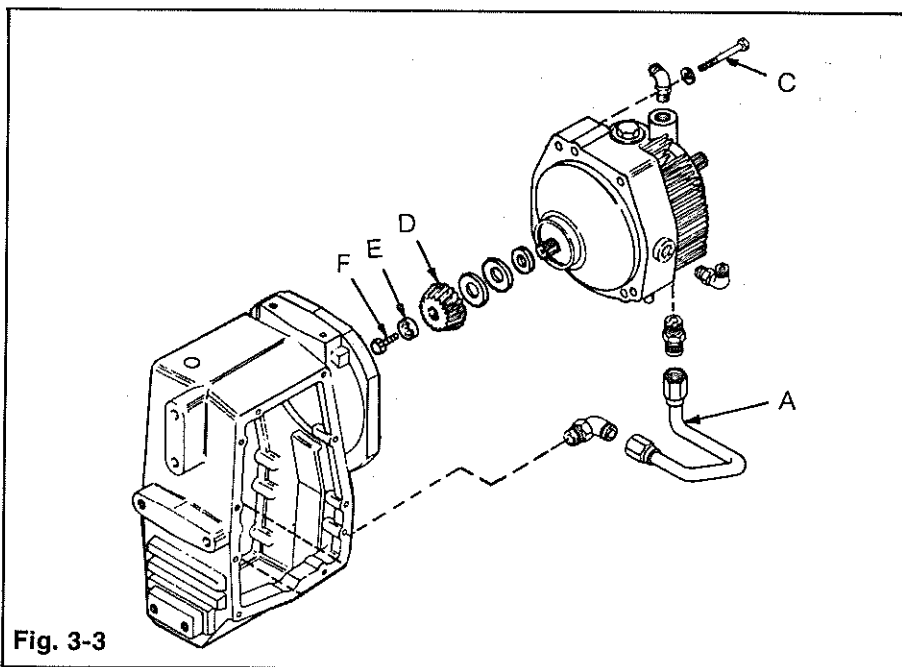
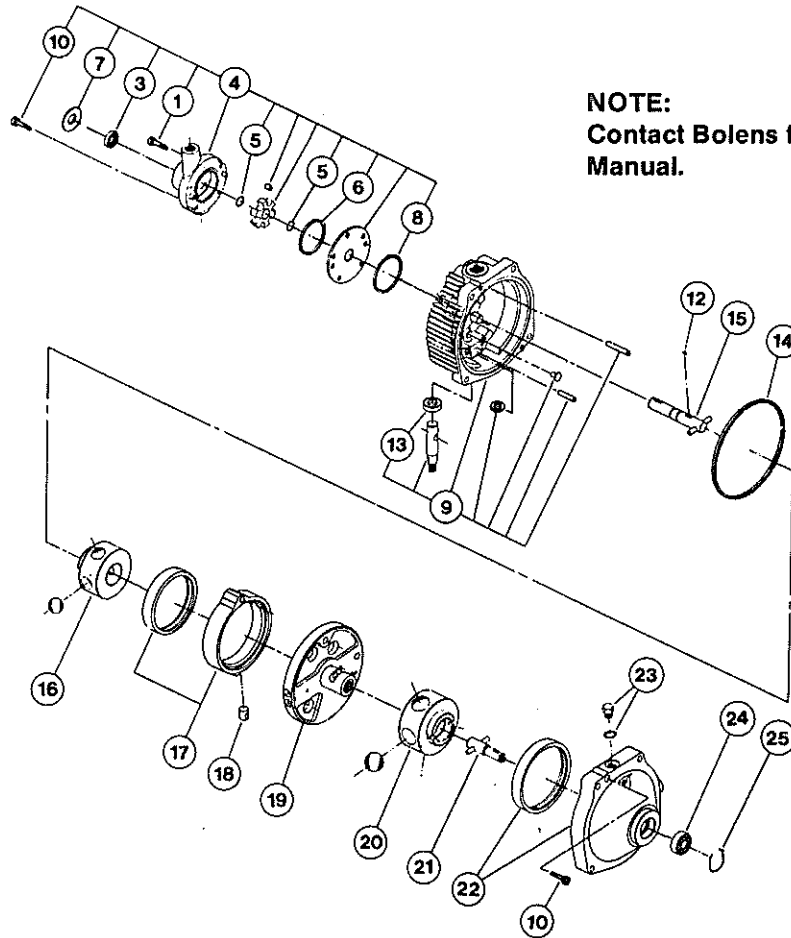

Fig. 3-3

HYDROSTATIC BREAKDOWN



NOTE:
Contact Bolens for an Eaton Repair Manual.

REFER TO THE INDIVIDUAL TRACTOR PARTS LIST FOR PART NUMBERS

1 Socket Screw 5/16-18 x 1-3/4 (Incl. w/Ref. 4)1	14 Square Seal Ring1
3 Oil Seal (Incl. w/Ref. 4)1	15 Input Shaft Sub Ass'y1
4 Charge Pump Kit (Incl. Ref. 1, 3, 5, 6, 7, 8, 10, 12)1	16 Pump Rotor & Ball Ass'y1
5 Snap Ring (Incl. w/Ref. 4)1	17 Cam Ring Ass'y1
6 Sq. Seal Ring (Incl. w/Ref. 4)1	18 Cam Ring Insert1
7 Grass Shield (Incl. w/Ref. 4)1	19 Pintle Ass'y (Incl. Internal Parts) . . .1
8 Sq. Seal Ring (Incl. w/Ref. 4)1	20 Motor Rotor & Ball Sub Ass'y1
9 Cover Sub Ass'y (Incl. w/Ref. 13) . . .1	21 Output Shaft Sub Ass'y1
10 Socket Hd. Screw 5/16-18 x 1-1/4 (Incl. w/Ref. 4)1	22 Body Ass'y (Incl. Ref. 21, 24 & 25) . .1
12 Drive Pin (Incl. w/Ref. 4)1	23 O-Ring Plug Sub Ass'y1
13 Oil Seal (Incl. w/Ref. 9)1	24 Ball Bearing (Output)1
	25 Retaining Ring1

HYDROSTATIC RE-INSTALLATION

INSTALLATION

(Fig. 3-4)

1. Clean the mounting surface of all oil, grease and dirt before re-installing the hydrostatic. Run a bead of silicon rubber around the mounting surfaces and the insides of the bolt holes. Secure with the four (4) capscrews and lockwashers (C) removed earlier. Torque the mounting screws to 24 ft./lbs. (32.5 N-m) when fastening.
2. Reinstall hydraulic line (A) removed earlier and tighten fittings.
3. If replacing hydrostatic, install a new woodruff key into the control shaft.
4. Install control shaft arm (B) and secure with washer and lock nut removed earlier. Torque to 6.25 ft./lbs. (8.5 N-m).

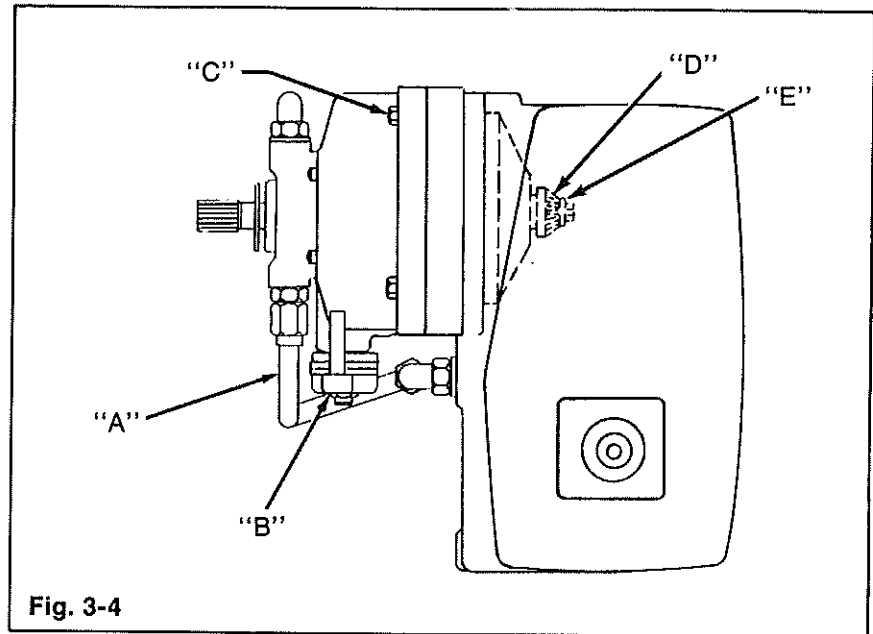

Fig. 3-4

NOTE: WHEN INSTALLING THE TWO PIECE DRIVESHAFT ON LATER MODELS, MAKE SURE THAT IT IS PROPERLY ASSEMBLED. ARROWS OR MARKS ON THE TWO PARTS MUST BE ALIGNED.

TRANSAXLE REMOVAL

1. Remove seat switch wire, seat and fender assemblies.
2. Remove tunnel (A) Figure 3-5
3. If transaxle is to be worked on, drain and dispose of fluid.
4. Remove seat switch wires from hydraulic tubes by cutting nylon wire ties.
5. Remove cotter pin and disassemble pivot block and brake rod (B) from front cross shaft.

6. Remove cotter pin and washer and disassemble pivot block and control rod (C) from the foot pedal shaft.

7. Unfasten both hydraulic tube lines at the hydrostatic end.

NOTE: Oil will be drained from these lines.

8. Scribe a line (D) on the inside L.H. frame, along the rear of quadrant support plate (E).

NOTE: This support must be removed and the scribed line will help in reassembly later.

9. Remove the quadrant support plate with assembly links.

10. Block up the tractor at mid frame till the rear wheels are just off the floor surface.

11. Remove the four capscrews (F) and two clamps (G) securing the transaxle to the frame. Remove fender support (H) at this time.

12. Place one foot on the rear hitch or use a bar in rear hitch hole to balance the transaxle while removing.

13. Slowly roll the complete transaxle and hydro back and out of the frame.

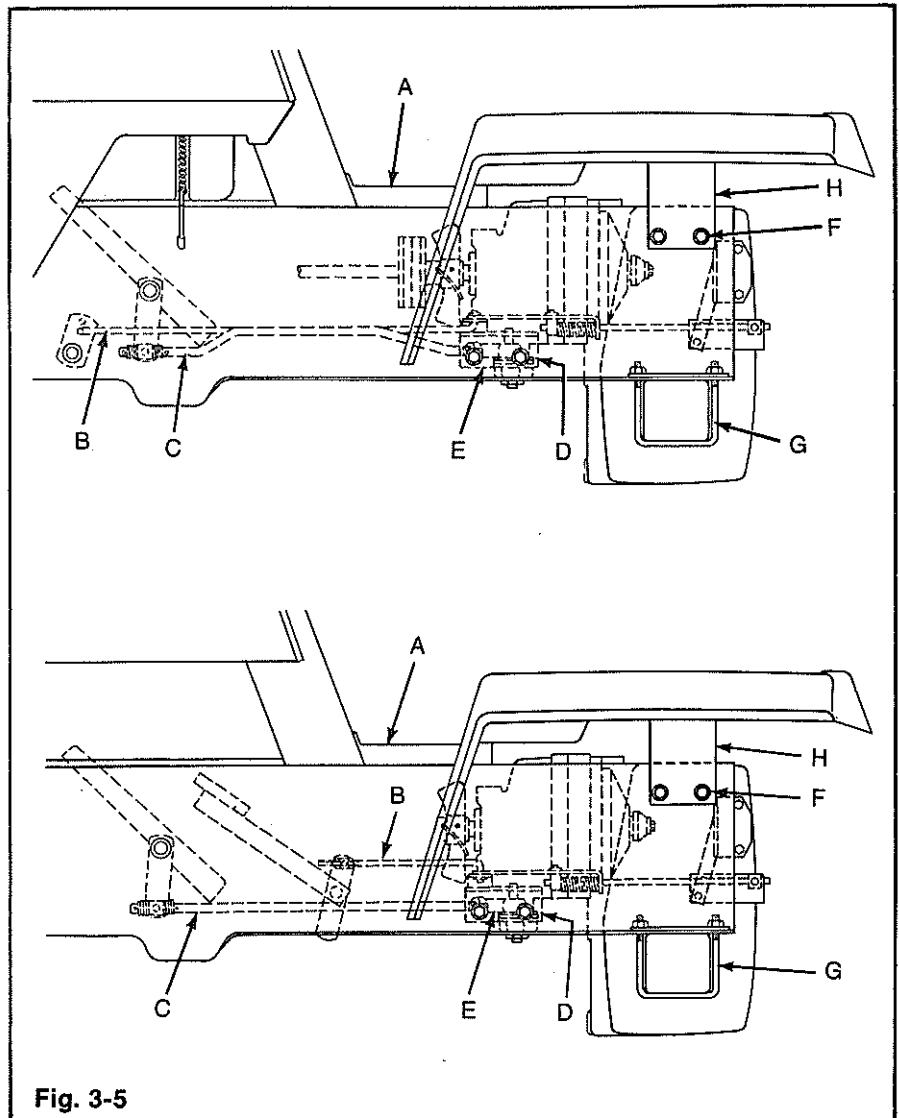

Fig. 3-5

14. After the transaxle assembly has cleared the frame, tip the transaxle backward to rest on a 6" block.

NOTE: Refer to page 3-7 for exploded view of complete assembly.

TRANSAXLE ASSEMBLY HYDROSTATIC MODELS

- | | | |
|------------------------------|---------------------------------|------------------------------|
| 1. Dipstick | 15. Hex Hd Screw 3/8-16 x 1-1/2 | 29. Axle Gear 47T |
| 2. Tube | 16. Needle Bearing | 30. Flange Screw 5/16-18 x 4 |
| 3. Transaxle Housing | 17. Gear Ass'y 50T - 16T | 31. Shim |
| 4. Oil Seal | 18. Dowel Pin | 32. Tubular Spacer |
| 5. Needle Bearing | 19. Hex Lock Nut 3/8 | 33. Thrust Race |
| 6. Gear 56T | 20. Differential Cover | 34. Thrust Bearing |
| 7. Woodruff Key | 21. Gear 22T | 35. Needle Bearing |
| 8. Woodruff Key | 22. Retaining Ring | 36. R.H. Axle |
| 9. Pinion Shaft Assembly 24T | 23. Pipe Plug | 37. Woodruff Key |
| 10. Thrust Race | 24. Dowel Pin | 38. L.H. Axle |
| 11. Thrust Bearing | 25. Pinion 10T | 39. L.H. Transaxle Cover |
| 12. Needle Bearing | 26. Retaining Ring | 40. Oil Seal |
| 13. R.H. Transaxle Cover | 27. Pinion Shaft | |
| 14. Lock Washer 3/8 | 28. Differential Carrier | |

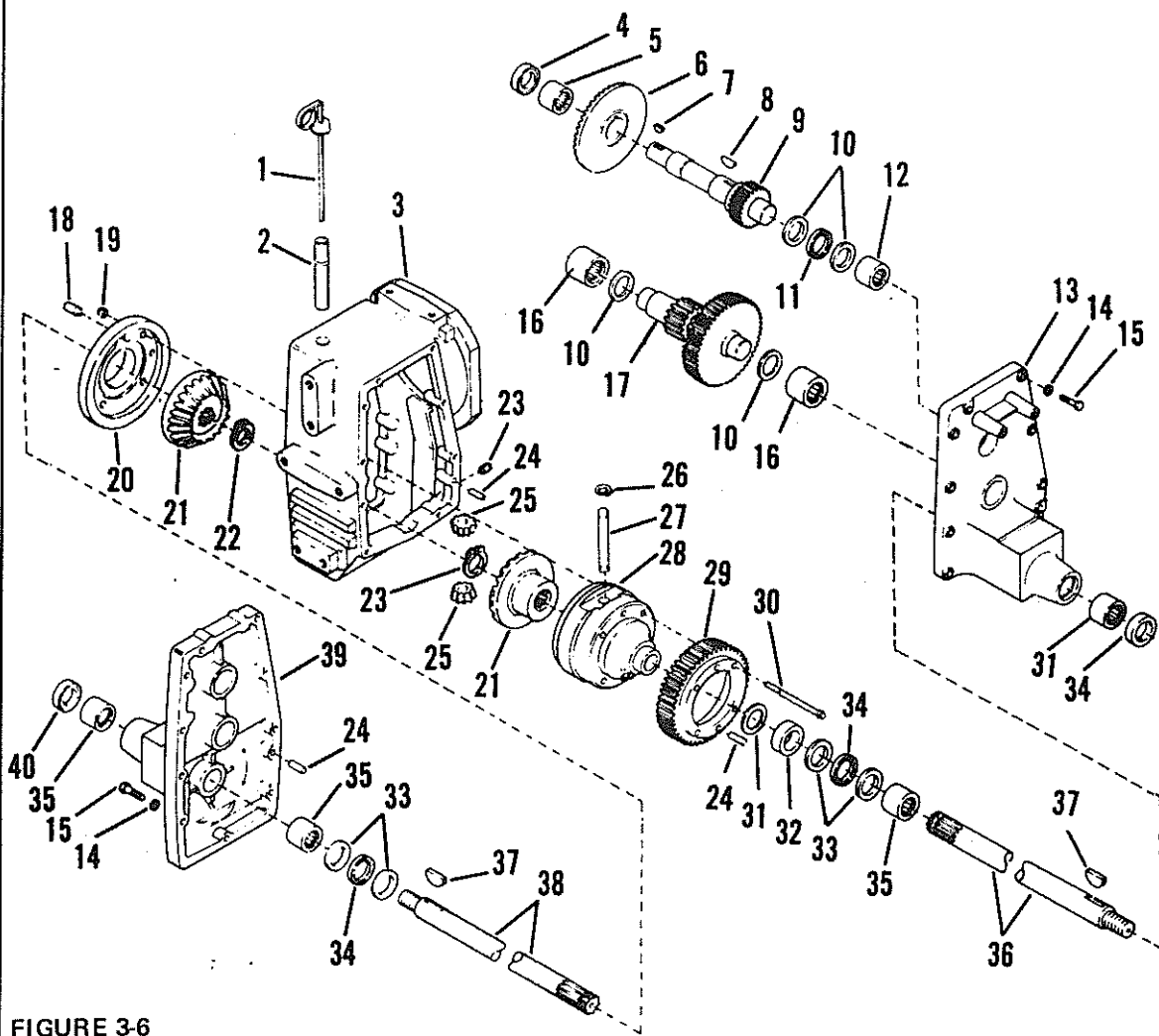

FIGURE 3-6

TRANSAXLE DISASSEMBLY HYDROSTATIC MODELS

NOTE: SEE TRANSAXLE REMOVAL PAGE 3-6 AND HYDROSTATIC REMOVAL PAGE 3-3 BEFORE SERVICING TRANSAXLE.

TRANSAXLE ASSEMBLY MUST BE REMOVED FROM TRACTOR AND HYDRO MUST BE REMOVED BEFORE TRANSAXLE CAN BE SERVICED.

NOTE: OUTER AXLE BEARINGS CAN BE REPLACED WITHOUT DISASSEMBLING TRANSAXLE. SEE PAGE 3-11 FOR PROCEDURE.

NOTE: KEEP TRACK OF THE POSITIONS OF ALL SHIMS, WASHERS AND GASKETS REMOVED DURING DISASSEMBLY. THESE ITEMS WILL HAVE TO BE REPLACED DURING RE-ASSEMBLY.

REPLAC DAMAGED OR BADLY WORN SHIMS AND WASHERS, AND ALL GASKETS DURING RE-ASSEMBLY USE ONLY ORIGINAL BOLENS PARTS.

(Fig. 3-8)

4. Remove nine (9) bolts holding left-hand transaxle cover and lift off center transaxle cover. Clean any gasket residue off cover flanges.

5. Simultaneously lift pinion/bevel gear assembly (E) and reduction gear assembly (F) out of gear case. **NOTE: Pinion gear assembly may require a slight wiggle to dislodge.**

6. If differential disassembly is required, it will be necessary to remove the left-hand wheel assembly at this time.

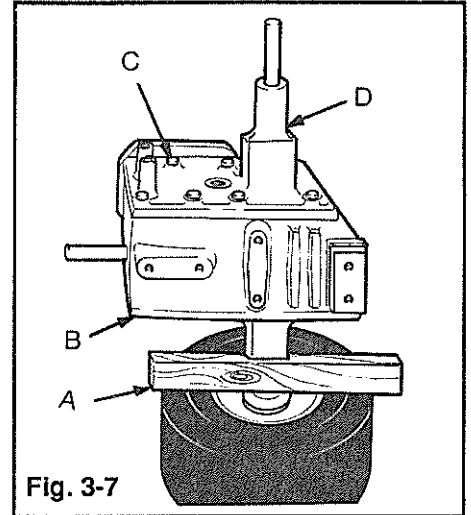

Fig. 3-7

Axle/differential assembly (G) will then lift out **NOTE: For differential servicing, see page 3-9.**

7. For transaxle re-assembly, proceed to page 3-11.

on some models, the bevel gear (H) can be removed from the shaft if replacement is necessary. A woodruff key is used to prevent the bevel gear from turning on the pinion shaft.



CAUTION

DO NOT DISASSEMBLE WITH TRANSAXLE PROPPED ON RIGHT-HAND WHEEL ASSEMBLY. TRANSAXLE CANNOT BE REASSEMBLED FROM THIS SIDE.

3. Remove eight (8) bolts (C) holding right-hand transaxle cover (D). Remove right-hand transaxle cover. Clean any gasket residue off cover flanges.

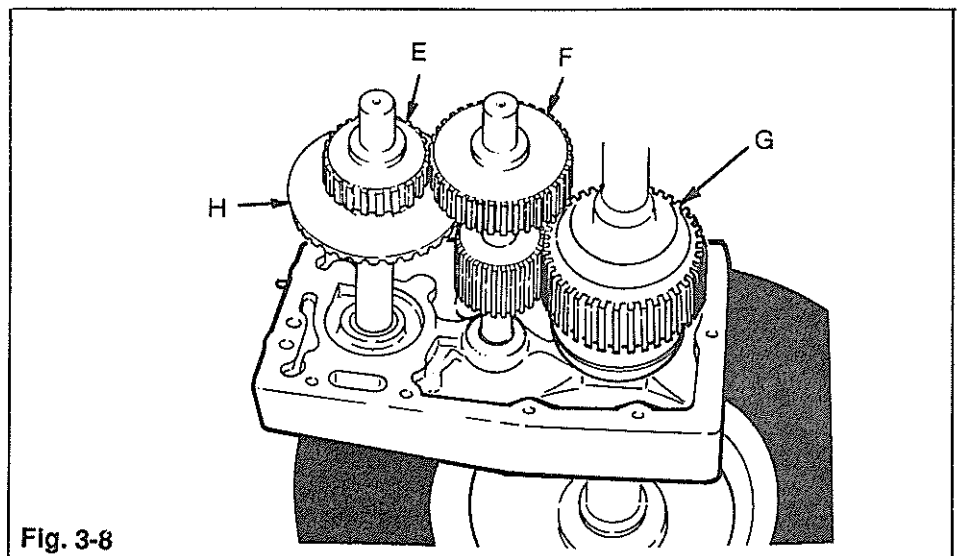

Fig. 3-8

DIFFERENTIAL ASSEMBLY/RE-ASSEMBLY HYDROSTATIC MODELS

DISASSEMBLY

(Fig. 3-9, 3-10 & 3-11)

1. Remove four (4) 5/16 ferry head bolts (I) from differential case. To open case from this point, it may be necessary to set the differential/axle assembly onto the end of the right-hand axle, and then tap gently down on the bull gear with a soft-faced mallet. The remaining internal parts inside the differential can be disassembled, if necessary, by removing snap rings. Pay close attention during disassembly of these items so they can be re-assembled in the proper manner. Side gear may be removed from axle after removing snap ring (J).

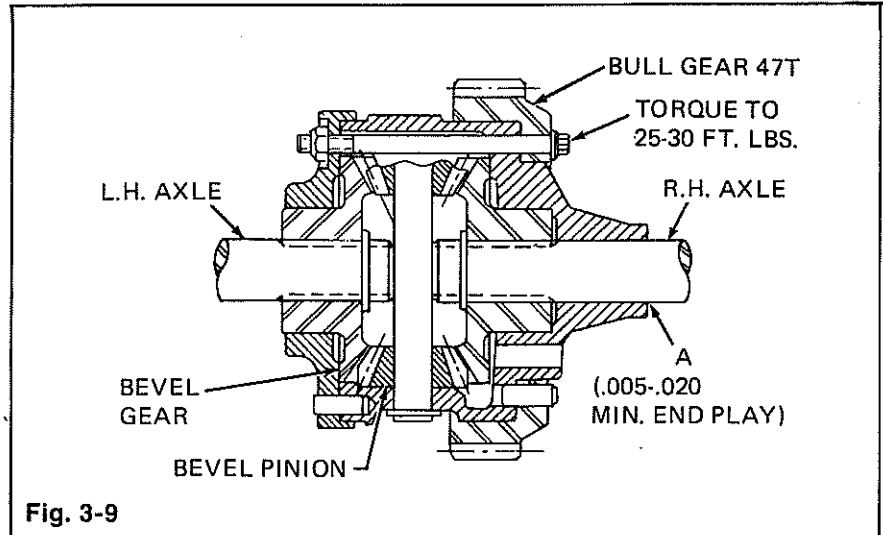

2. Check internal parts for excessive wear or damage. Replace if necessary. USE ONLY GENUINE BOLENS REPLACEMENT PARTS.

RE-ASSEMBLY

3. Re-assemble any disassembled internal differential parts. The two pinion gears slide on the pinion shaft and are held in position by the side gears when the carrier is assembled.

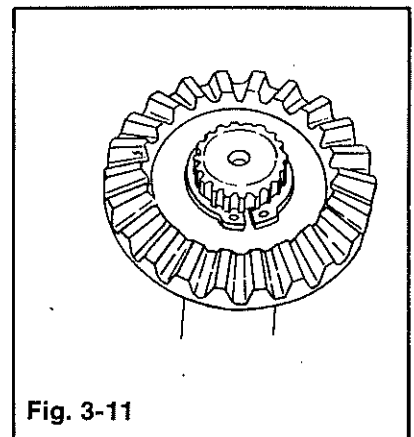
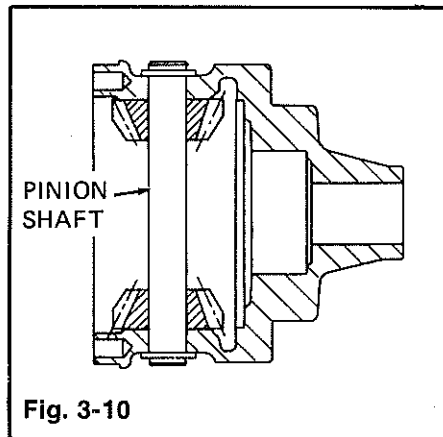

NOTE: BOLT HEADS ON DIFFERENTIAL ASSEMBLY SHOULD BE ON THE RIGHT-HAND SIDE.

4. When the internal differential parts have been re-assembled, put the differential case back together and replace the four (4) ferry head bolts (I). Torque to 25 to 30 ft. lbs. (33 to 40 N-m).

TRANSAXLE RE-ASSEMBLY PROCEDURE

1. Check needle bearings in side housings. If needles show signs of pitting or any other damage replace them. Use a needle bearing driver and seat bearing to a depth of $1/32''$ to $1/16''$ (0.78 - 1.57 mm) below the machined surface of the upper two bearings. The axle bearing must be seated to a depth of $1/4''$ (6.4 mm) below the machined surface.

NOTE: ALWAYS INSTALL THE NEEDLE BEARINGS WITH THE STAMPED END (THE END WITH IDENTIFICATION MARKINGS) AGAINST THE BEARING DRIVING TOOL.

2. Install carrier and axle assembly Figure 3-13 into the left side housing. Be careful not to damage axle seal in end of housing. Apply a $1/32''$ (0.8 mm) bead of sealant around cover flange. Keep bead to the inside of bolt holes.
3. Bolt left side housing with axle assembly to the center housing. Torque housing cap screws to 30 ft. lbs. (40 N-m).
4. The 56T bevel gear Figure 3-7 can be removed from the shaft if replacement is necessary. A woodruff key is used to prevent the bevel gear from turning on the pinion shaft.
5. To install the assembled bevel gear and pinion shaft into the transaxle, mesh the cluster gear and the above assembly together.
6. Make sure thrust washer is installed on cluster gear, and slide shafts into the needle bearings.

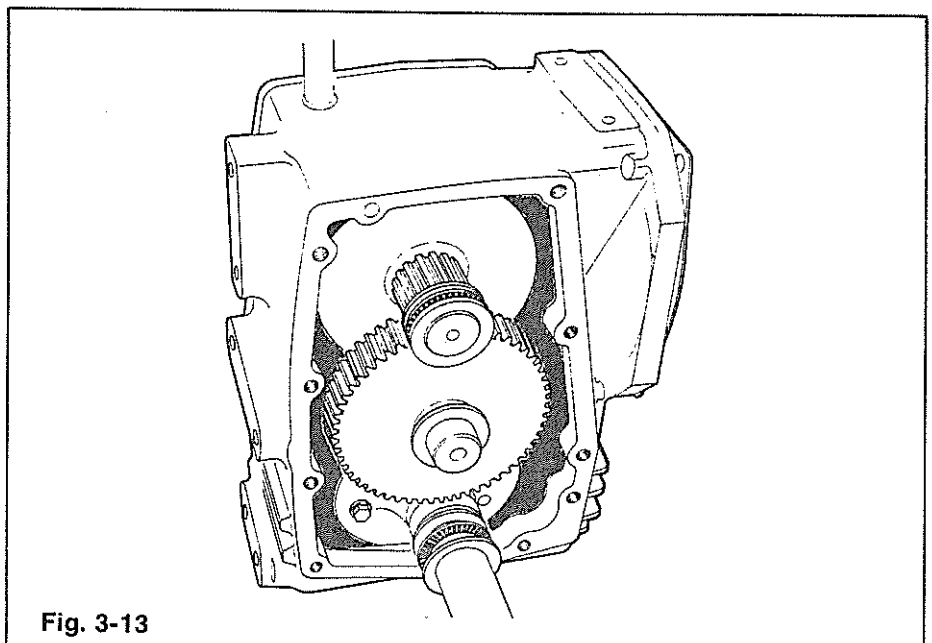
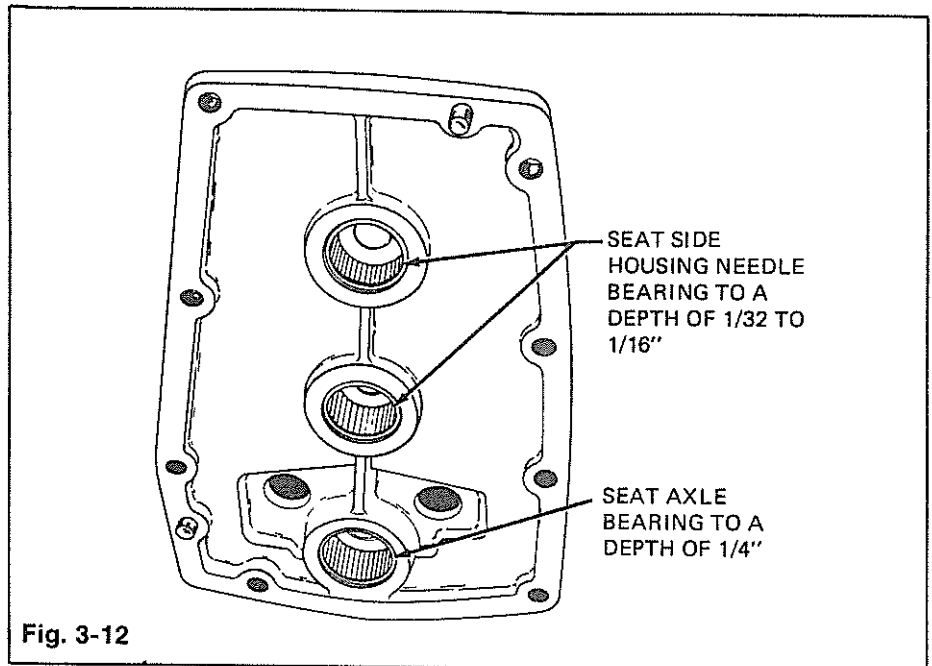

7. The right side of the bevel gear must have a thrust bearing assembly. The cluster gear must have a thrust washer and the axle shaft a spacer and torrrington bearing assembly. Refer to Figure 3-13. After the bearings and spacers are

installed, the right side housing can be bolted in place. Apply a $1/32''$ (0.8 mm) bead of sealant around cover flange. Keep bead to the inside of bolt holes. Be careful not to damage axle seat. Slide cover on and torque cap screws to 30 ft. lbs. (40 N-m).

TRANSAXLE RE-ASSEMBLY PROCEDURE (CONT'D) HYDROSTATIC MODELS

8. (Fig. 3-14)

Check exterior axle bearings in ends of axle housings. Service these bearings the same as interior bearings. Exterior bearings should be seated $1/32''$ to $1/16''$ (0.78 - 1.57 mm) below counter bore for the axle seal. NOTE: Exterior axle bearings can be serviced without disassembling transaxle.

9. Axle seals should be replaced whenever unit is repaired. Use a seal driver to drive seals until they bottom in axle housing counter bore.

10. Install differential carrier/axle assembly into the left side housing. Be careful not to damage axle seal when installing it in end of housig. Make sure all shims and washers are in place as they were when removed. See Fig. 3-15 for reference.

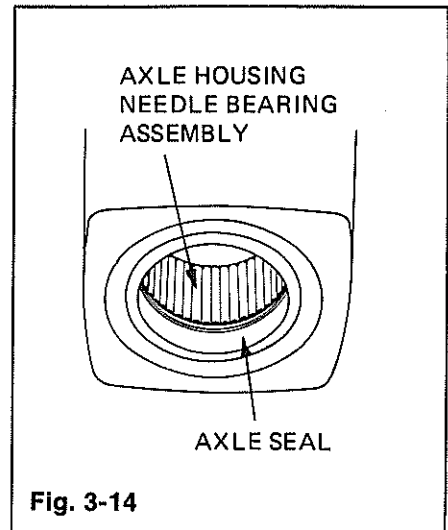

Fig. 3-14

NOTE: REFER TO PAGES 3-12 & 3-13 FOR BEARING AND SEAL INSTALLATION PROCEDURES.

3

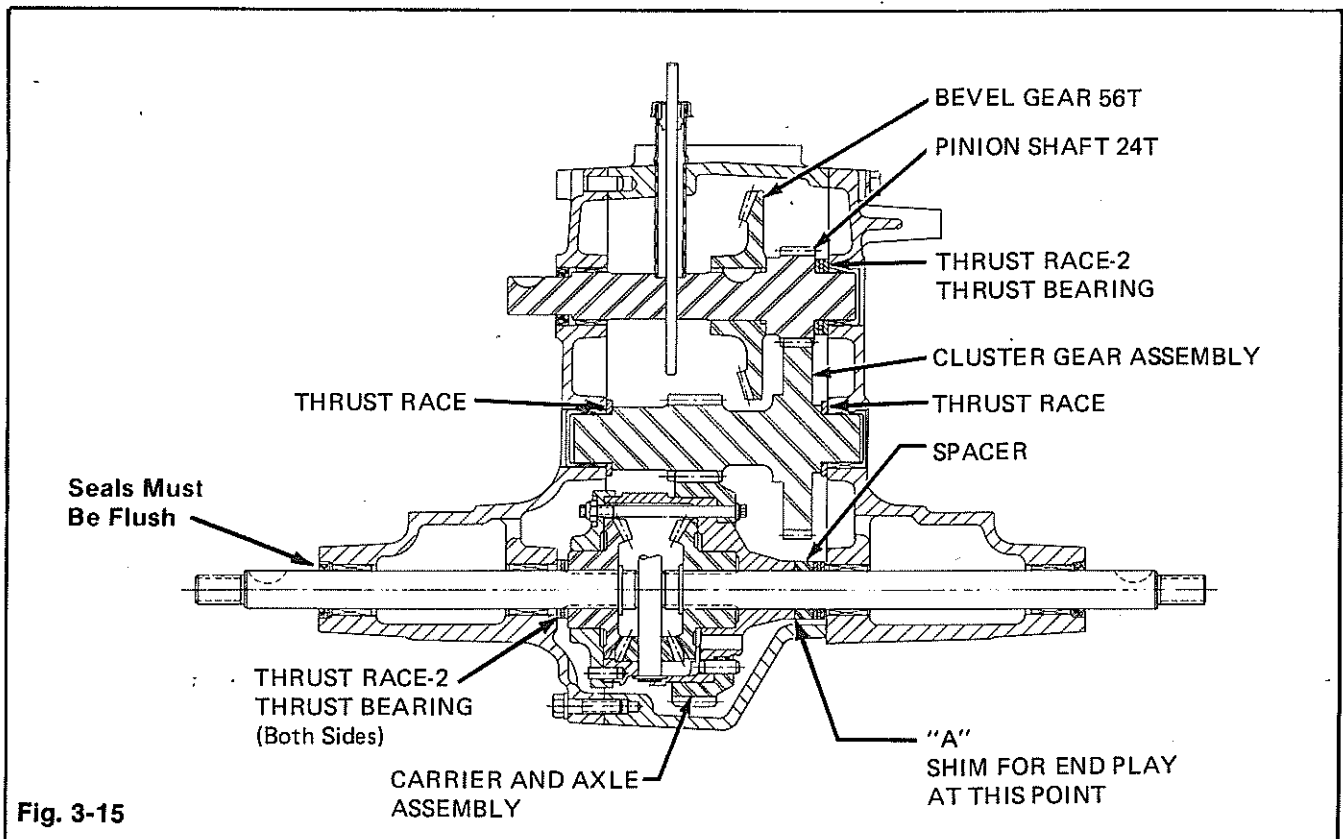
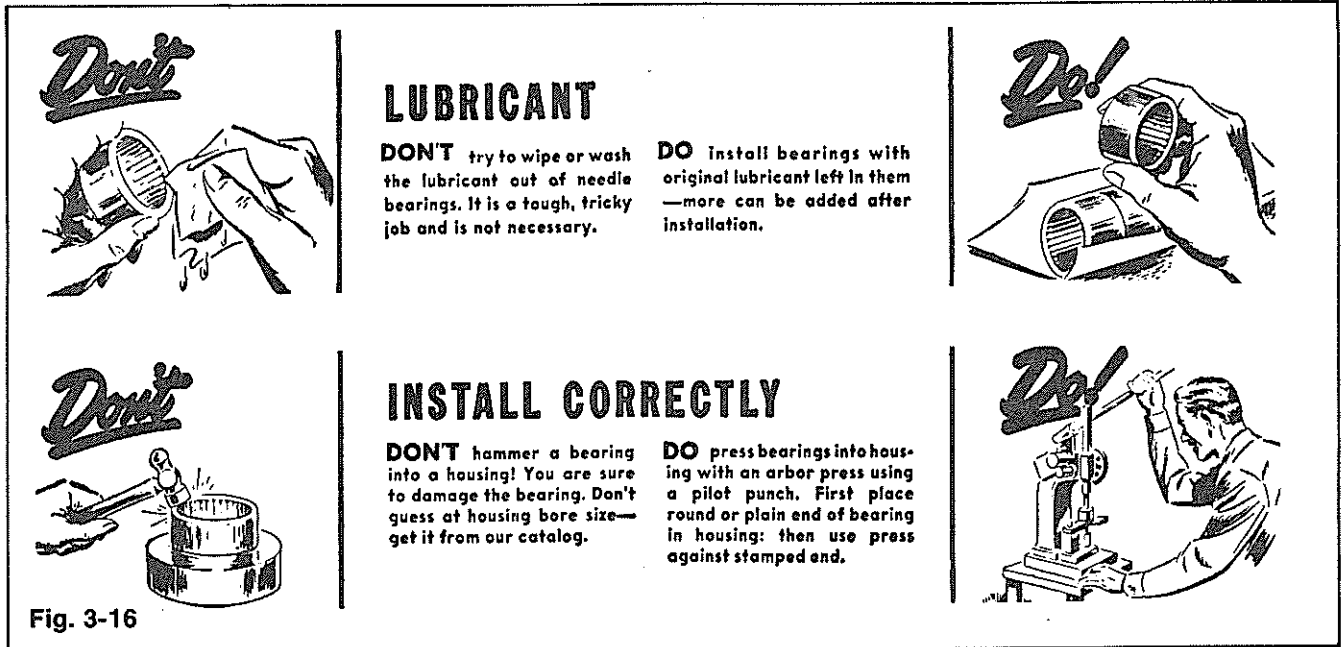

Fig. 3-15

TRANSAXLE RE-ASSEMBLY (CONT'D)
HYDROSTATIC MODELS

BEARING INSTALLATION



1. Use an arbor press, or a similar method, whenever possible (as illustrated).
2. The punch should have a pilot to keep the bearing in line, as shown.
3. Place the stamped end of the bearing against the shoulder of the punch. The unstamped end of the bearing will lead best into the housing bore.
4. Do not wipe the grease off the bearings. Do not allow dirt to contaminate the grease.

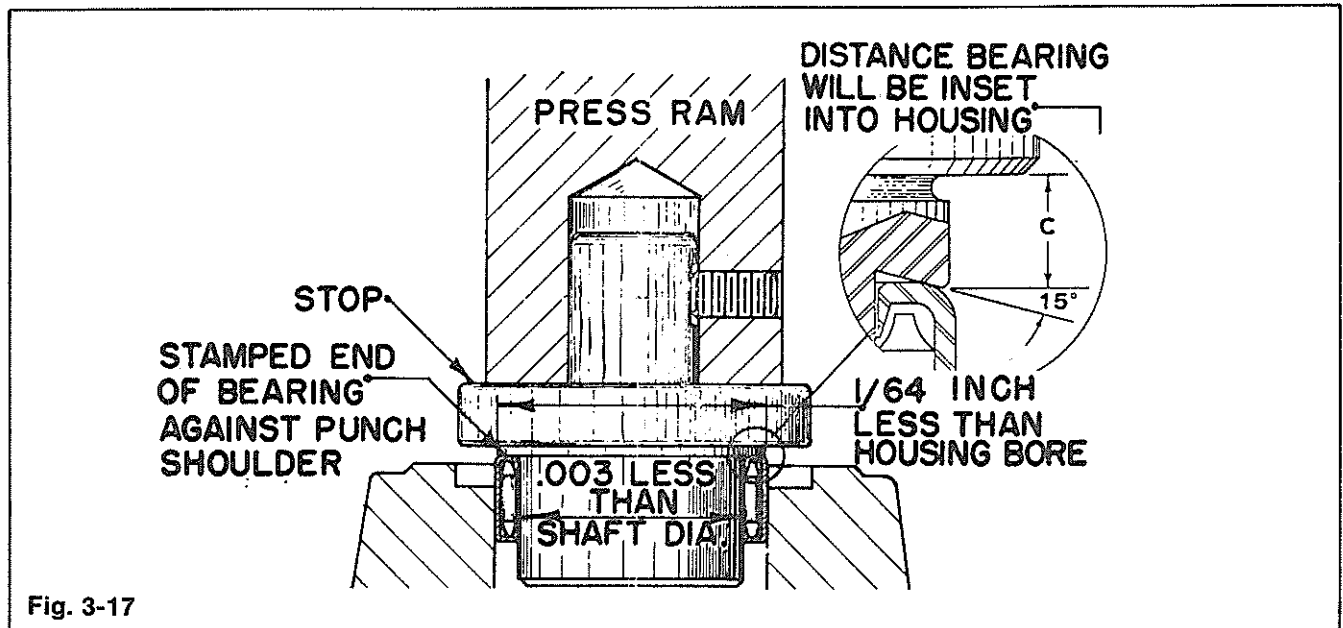

TRANSAXLE RE-ASSEMBLY (CONT'D) HYDROSTATIC MODELS

OIL SEAL INSTALLATION

1. Be sure housing bore diameter, bore depth and shaft diameter are correct and within the recommended tolerances. Inspect all surfaces for scratches or nicks.
 2. Provide radius or chamfer at housing bore entrance.
 3. Be sure sealing lip has not been damaged.
 4. Lubricate sealing lips with any light machine oil before installing.
 5. Apply a light coat of any suitable sealing compound to O.D. of seal to provide a margin of safety against seepage through the press-fit in housing bore. Extreme care must be taken to avoid depositing any compound on the sealing member.
 6. Install seal with lip facing lubricant.
- (Fig. 3-18)**
7. When possible, chamfer end of shaft over which seal must pass; otherwise, use a sleeve as illustrated.
 8. Press seal into housing with a smooth, uniform pressure applied by a press-fitting tool (C). If shaft is already in place, use a sleeve-type press-fitting tool.
 9. Whenever possible, use an arbor press to insert seal into housing. Be sure seal is not cocked when applying pressure. It is best to seat seal against a shoulder in the bore to help prevent cocking of the seal.

10. When the shaft is assembled from reverse side of sealing lip, no special precautions are required other than removing all burrs and sharp corners from shaft. When the shaft enters against the sealing lip, a tapered sleeve made to the dimensions shown at (A) must be used. Use a sleeve as shown (B), when seal must pass splines, keyways or holes. The edges of the splines, keyway or holes should be rounded and lubricated with a heavy grease if the use of an assembly sleeve is not possible.

11. If the machine is to be painted where seals are exposed, mask the shaft and sealing lip to prevent paint from being deposited in these areas. If the paint is to be baked on, be sure the baking temperature does not exceed the operating temperature of the seal to avoid damaging the sealing member.

3

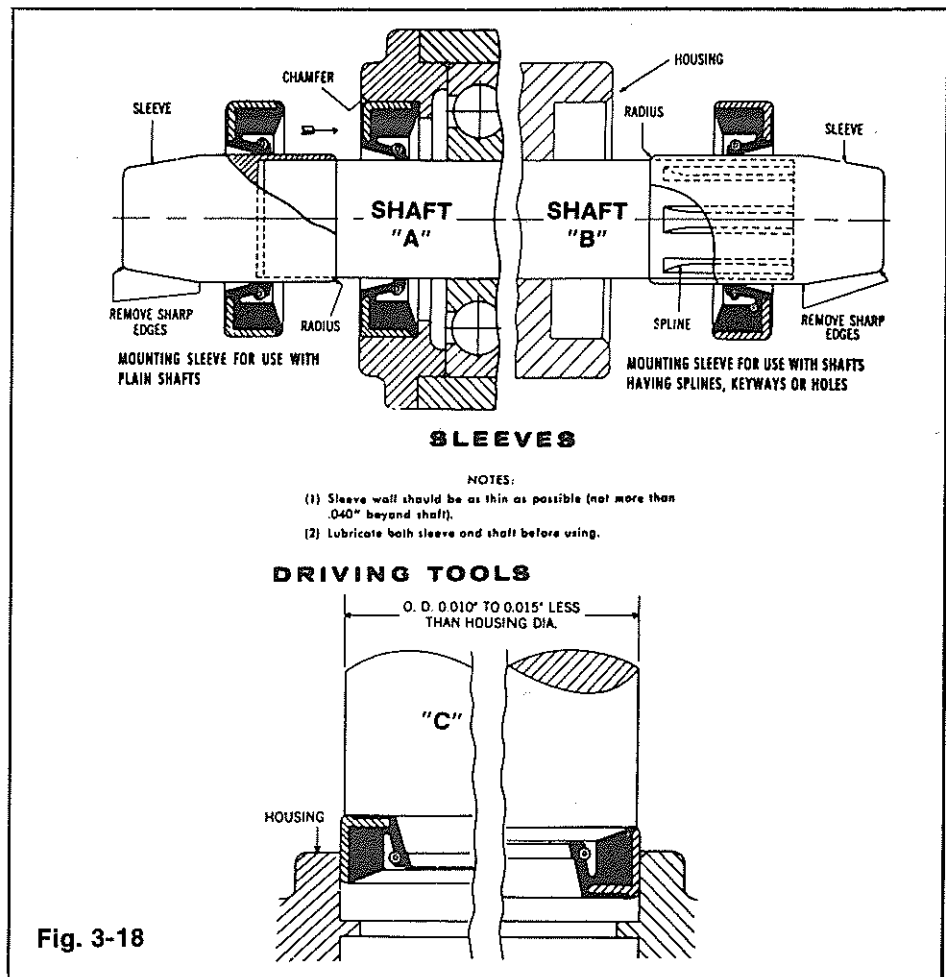

TRANSAXLE RE-INSTALLATION HYDROSTATIC MODELS

NOTE: Hydro should be installed in transaxle before continuing.

1. Position quadrant support plate (D) and linkage into place before assembly.
2. Tip the quadrant up and walk the transaxle into the frame.

NOTE: On later models it may be necessary to raise the frame even further off the blocks to clear the fuel tank support.

(Figs. 3-15 & 3-16)

3. Stabilize the transaxle by temporarily installing a mounting screw and nut into one of the top left hand transaxle support holes (F) in the frame.
4. Position the quadrant support plate in place using the scribed line (D) and tighten. Plate must be parallel with frame after assembly.

NOTE: Make sure all rods are in the right position for later assembly.

5. Position the two (2) axle U-bolts (G), in place with the flat support spacer and turn the nuts on a few turns.
6. Remove the blocks from beneath the frame.
7. Remove mounting screw (F) and nut assembled in step 3.
8. Align the seat support bracket (H) over the frame and fasten the four (4) mounting screws and two (2) nuts into the frame.
9. Tighten the four (4) U-bolt nuts.

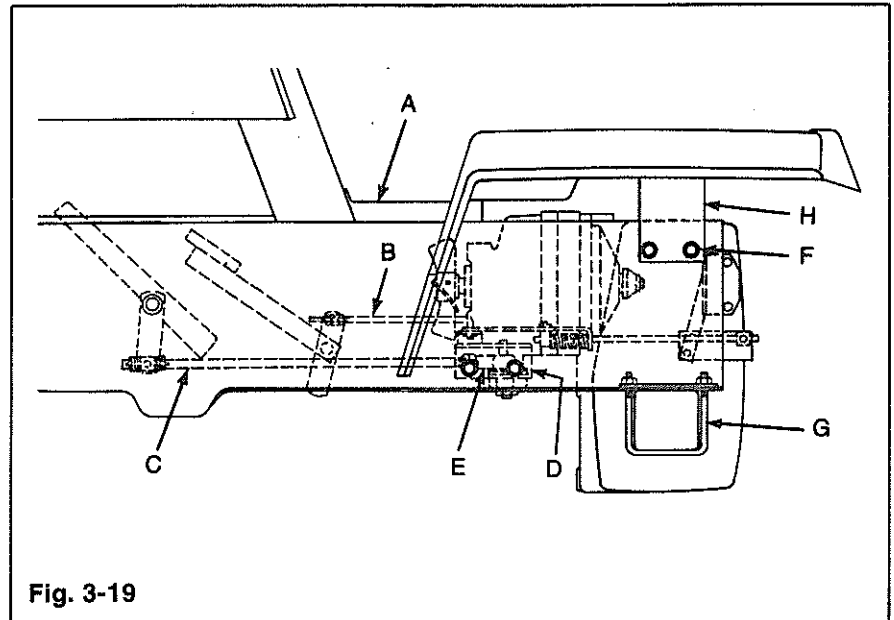

Fig. 3-19

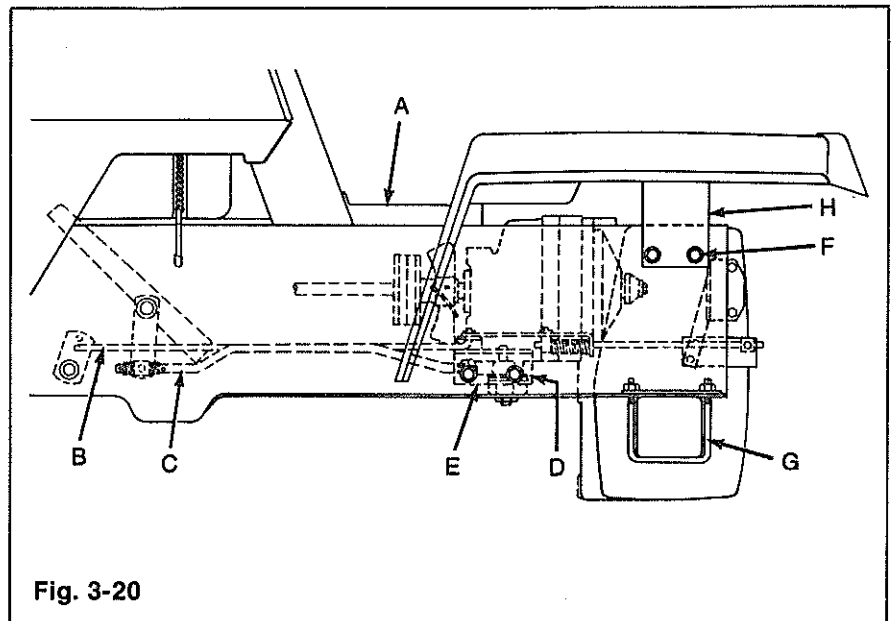

Fig. 3-20

10. Slide driveshaft onto input shaft and secure driveshaft hub with set screws.

NOTE: Provide 1/8" clearance between hydro and driveshaft hub.

Make sure that the two-piece driveshaft is properly installed. The arrows or marks on the two parts must align with one another.

11. Secure the brake rod (B) in the

TRANSAXLE RE-INSTALLATION (CONT'D) HYDROSTATIC MODELS

lower hole of the cross shaft arm with a cotter pin.

12. Secure hydrostatic control rod (C) in place with the washer and cotter pin previously removed..
 13. Reconnect and tighten the two (2) hydraulic tubes to the hydro.
 14. Fill the transaxle with approximately 8 qts. (7.5L) of new transmission fluid. Change oil filter if necessary.
 15. Remove spark plug from engine and crank for approximately 15 seconds to fill hydro with fluid. Re-install spark plug.
 16. Start unit and operate at a low engine RPM. If equipped, actuate hydraulic lift lever. This will fill the rest of the system with fluid. Shut off tractor engine.
 17. Carefully block up rear of tractor. Place travel pedal into neutral position. Start the engine and release the brakes. If the wheels move in a forward direction, move quadrant support plate (D) toward the front of the tractor. If the wheels move in the reverse direction, move the support plate toward the rear.
 18. Stop unit and check fluid level. Add fluid if necessary.
- (Figs. 3-21 & 3-22)**
19. Position the fender in place and connect the wires to the seat switch. Secure the fender.
 20. Re-install the seat.
 21. Re-install the tunnel (A).

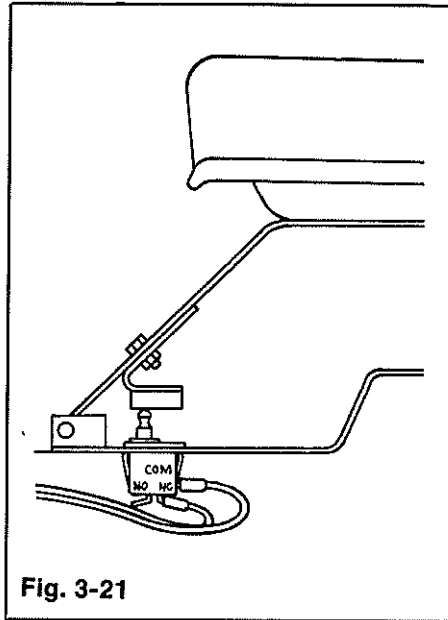

Fig. 3-21

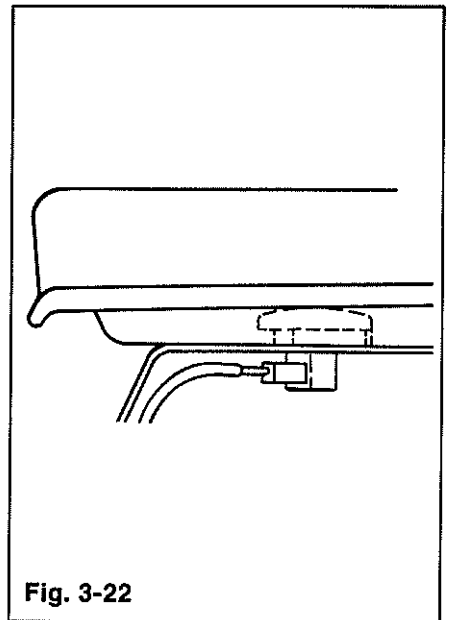

Fig. 3-22

GEAR DRIVE INTRODUCTION

Peerless makes power transmission gear drives for use in all types of lawn and garden equipment.

ANGLE DRIVES

These units are used primarily to change the direction of drive at the point where the working equipment attaches. These units consist of input shafts, output shafts, and the beveled gearing necessary to change the direction of power transmission at right angles. By positioning the drive bevel gear on the input shaft nearest the input end, opposite rotation will be attained from that of switching the beveled gear around to the side away

from the input end of the shaft. Casing bearings are identical. The cover identifies each unit as being either a left-hand (LH) or a right-hand (RH) right angle drive.

TRANSAXLES

A combination transmission/differential axle is in one compact unit. The distinguishing features are: a massive casing, and a large shift lever opening. The obvious difference from the standpoint of application is that these units have four speeds forward and can be used with ground engagement operations such as tilling, etc.

IDENTIFICATION

IDENTIFICATION OF MODELS

All Peerless assemblies have a model number identification tag, or stamping.

On units containing axles (transaxles, or reduction gear and differential units), the identification should be visible by viewing the case/cover unit from below and behind as it is mounted in the equipment.

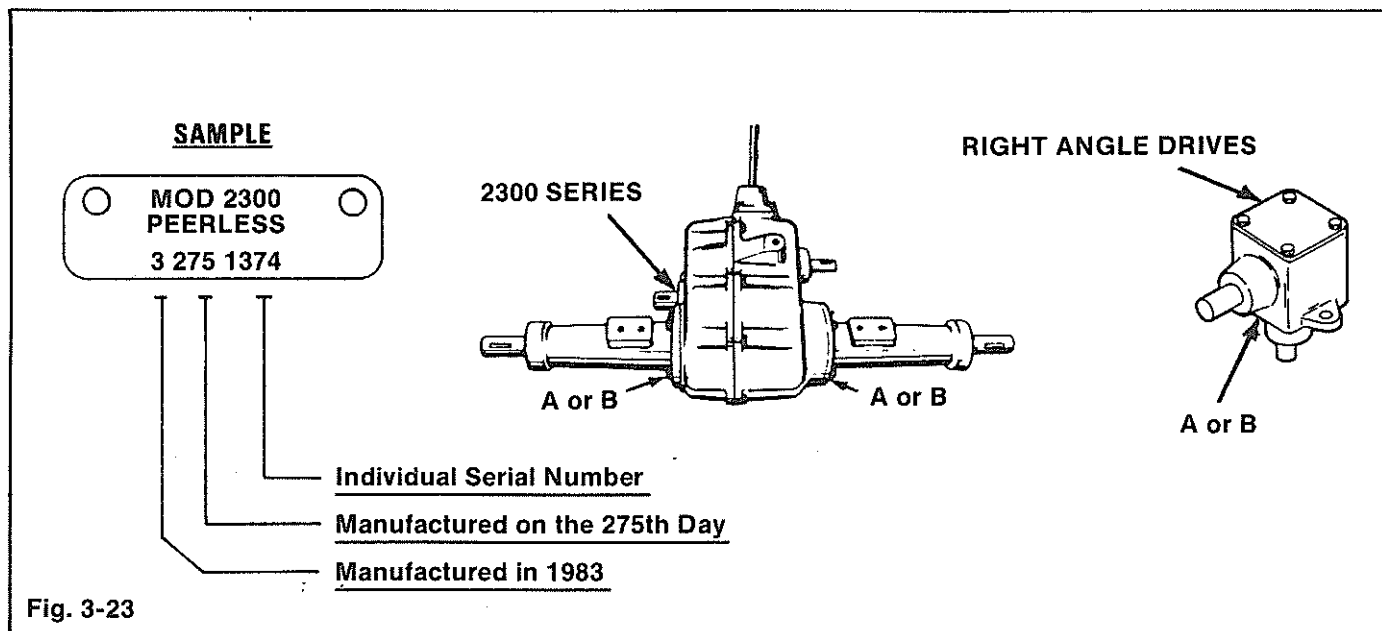

Early Models were not identified with a model number on the unit.
**THE MODEL NUMBER WILL BE FOUND ON: A. Metal tag attached to unit as illustrated.
B. Stamped on unit as illustrated.**

TRANSAXLE REMOVAL GEAR DRIVE

Repair work needed on the Peerless transaxle or Right Angle Gear Box should be done by an authorized Tecumseh/Peerless Dealer during the warranty period.

For Gear Drive servicing information, refer to the **Mechanic's Handbook--Tecumseh/Peerless Motion Drive Systems**. This manual is available from your local dealer, or from the Tecumseh Products Company, 900 North St., Grafton, WI 53024.

The transaxle assembly is filled at the factory with SAE EP90 transmission fluid. Check the fluid level once a year. To check level, park tractor on a flat surface and remove plug (A) on the front of the transmission. If the fluid is not to plug level, add at filler plug (B) until correct level is reached. Oil capacity is 3 pts. (1.4L).

TRANSAXLE REMOVAL (Figs. 3-24 & 3-25)

1. Remove seat and fender.
2. Prop up tractor frame at mid-point.
3. Disconnect brake rod (C) and clutch rod (D) by removing washers and cotter pins.
4. Loosen two (2) belt guides (E) in frame.
5. Push idler (F) down and remove drive belt.
6. Remove shift lever knob.
7. Remove center transaxle mounting screw (G).

8. Remove the four (4) mounting screws (H) from the frame.

RIGHT ANGLE DRIVE REMOVAL

1. Remove the two (2) mounting bolts and belt guides (I) and (J) from the support bracket.

2. Slide the right angle gear box to the rear and remove.

NOTE: THE GEARBOX IS PACKED WITH 3 oz. OF TECUMSEH BENTONITE GREASE.

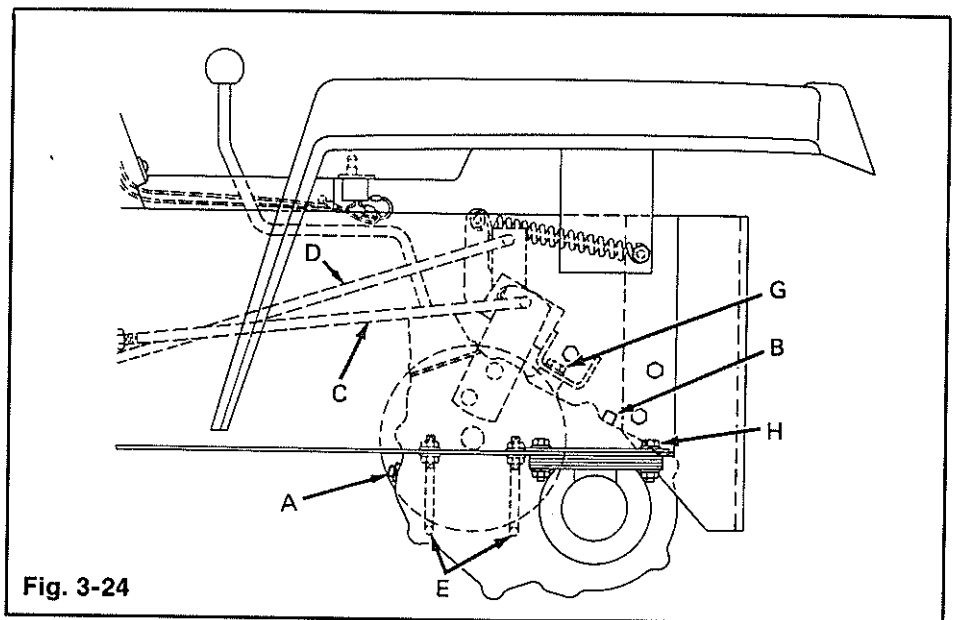

Fig. 3-24

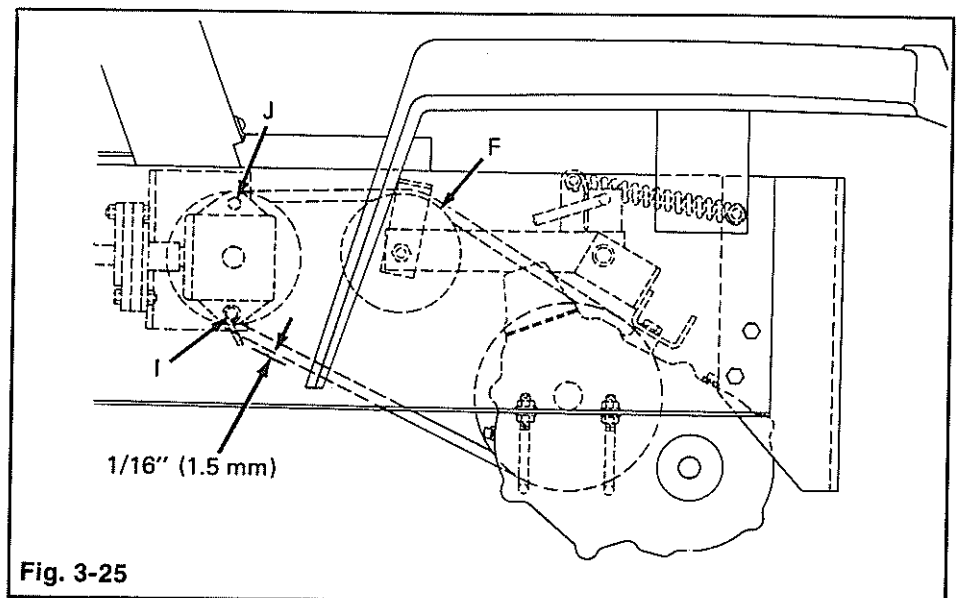

Fig. 3-25

GEAR DRIVE BREAKDOWN (CONT'D)

REF. NO.	DESCRIPTION
PEERLESS TRANSAXLE ASSEMBLY	
2	Ring, Snap
3	Ring, Quad
4	Pin, Drive
5	Housing, Shift Lever
6	Keeper, Shift Lever
7	Lever, Shift
8	Rod Ass'y., Shift (incl. items 9 thru 12 & 24)
9	Spring
10	Ball, Steel
11	Fork, Shifter
12	Rod, Shifter (3rd & 4th)
13	Rod Ass'y., Shift (incl. items 9 thru 11 & 14)
14	Rod, Shifter (Low)
15	Axle
16	Washer, Thrust
17	Capscrew, Hex. Hd. 1/4-20 x 3-1/4
18	Lockwasher, 1/4
19	Gear, Ring
21	Core, Body
22	Gear, Pinion
23	Shaft & Gear, Brake
24	Ring, Snap
25	Shaft & Bearing Ass'y., Pinion (incl. item 26)
26	Bearing
27	Gear Cluster Ass'y. (incl. item 28)
29	Bushing
30	Gasket, Case & Cover
31	Gasket, Shift Lever Housing
32	Gear, Shifting (3rd & 4th)
33	Gear, Shifting 1st, 2nd & rev.)
34	Gear Side
35	Gear Idler
36	Gear Cluster Ass'y. (incl. item 28)
37	Spacer
38	Ring, Snap
39	Shaft, Input
40	Spur Gear, Input Shaft
41	Washer, Thrust
42	Seal & Retainer Ass'y. (incl. item 45)
43	Gear, Output
44	Pinion, Output
45	Seal, Oil
46	Housing, Axle
47	Cover Ass'y., Transaxle (incl. items 54, 55, 57 59 & 63)
48	Case Ass'y., Transaxle (incl. items 54, 55, 57, & 63)

REF. NO.	DESCRIPTION
49	Capscrew, Socket Hd., 1/4-20 x 3/4
50	Pin, Dowel
51	Screw, Hex Hd., 5/16-18 x 7/8
52	Plug, Magnetic Drain
54	Bearing, Needle
55	Bearing, Needle
56	Bearing, Ball
57	Bearing, Needle
58	Bearing, Ball
59	Bearing, Needle
60	Seal, Oil
61	Washer
62	Shaft & Pinion
63	Bearing, Needle
64	Shaft, Reverse Idler
65	Spacer, Reverse Idler
66	Idler, Reverse
67	Spur, Gear (22 Teeth)
68	Bearing, Thrust
69	Carrier Ass'y., Differential (incl. item 71)
70	Carrier Ass'y., Differential (incl. item 71)
71	Bushing
72	"O" Ring
73	Washer, Thrust
74	Washer, Thrust
75	Plug, Pipe
76	Race, Thrust

RIGHT ANGLE GEAR BOX	MODEL 3890-P91 REPLACEMENT NO. 794251
-----------------------------	--

1	Head Ass'y., L.H. (incl. items 2 thru 16)
2	Self-tapping screw, Rd. Hd. 10-24 x 1/2
3	Cover
4	Gasket, Cover
5	Ring, Snap
6	Gear, Miter
7	Bearing, Ball
8	Shaft, Output
9	Housing, Right Angle Drive
10	Ring, Snap
11	Seal, Oil
12	Shaft, Input
13	Gasket, Cap
14	Cap & Seal Ass'y./ Retainer (incl. items 92 & 93)
15	Seal, Oil
16	Screw, Hex. Hd 1/4-20 x 7/8
17	Bearing, Ball

3

TRANSAXLE RE-INSTALLATION GEAR DRIVE

The transaxle assembly is filled at the factory with SAE EP90 transmission fluid. Check transmission fluid once a year. With the tractor on a flat surface, remove plug (A), on front of transmission. If oil is not to plug level, add at filler plug (B) until correct level is reached. Oil capacity is 3 pts. (1.4L).

2. Slide hub of drive shaft onto gearbox input shaft.
3. Position drive in support bracket and secure bolts (I) and (J) with belt guides in place. When fastening bolts, provide a 1/16" (1.5mm) clearance between belt guide and belt when drive is in engaged position.

TRANSAXLE RE-INSTALLATION (Fig. 3-27 & 3-28)

1. Slowly move transaxle assembly under tractor frame.
2. Re-install the four (4) mounting screws (H) to the frame.
3. Re-install center transaxle mounting screw (G).
4. Re-install shifter knob.
5. Push idler (F) down and re-install belt.
6. Tighten the two (2) belt guides to the frame. When securing these belt guides, provide a gap of 3/32 (2mm) between the guides and the belt.
7. Re-connect the brake rod (C) and clutch rod (D) by installing cotter pins.
8. Remove blocks from under tractor frame.
9. Install fender and seat.
10. Re-connect seat switch wires.

RIGHT ANGLE DRIVE INSTALLATION.

1. Position drive belt around right angle drive pulley.

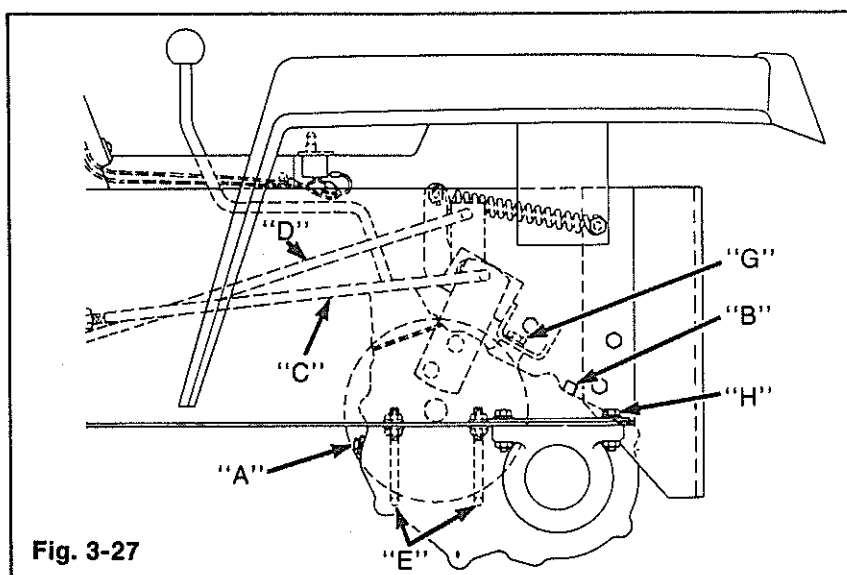

Fig. 3-27

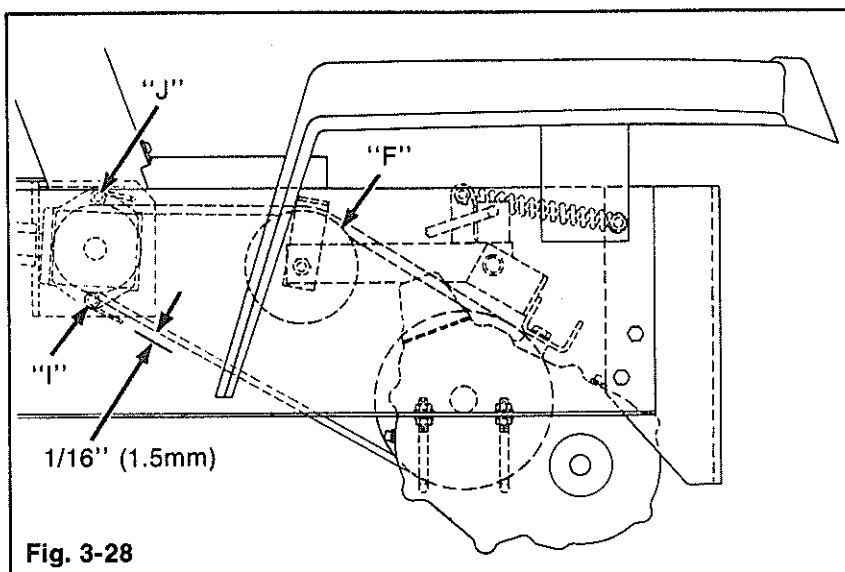

Fig. 3-28

TROUBLE SHOOTING GUIDE

PROBLEM	PROBABLE CAUSE	REMEDY
Hard starting.	<ol style="list-style-type: none"> 1. Fuel shut off valve closed. 2. Choke linkage not working properly. 3. Dirt in fuel system. 4. Engine flooded. 5. Carburetor out of adjustment. 6. Water in fuel system. 7. Dirty air filter. 8. If equipped with pulse pump-pulse line leaking. 	<ol style="list-style-type: none"> 1. Open valve. 2. Check linkage and repair. 3. Clean fuel lines, carburetor, and install new fuel filter. 4. Check linkage, carburetor float setting etc. 5. Adjust carburetor. 6. Clean system and refill with clean fuel. 7. Install new air filter. 8. Install new pulse line.
No fuel reaches carburetor.	<ol style="list-style-type: none"> 1. Empty fuel tank. 2. Fuel filter plugged. 3. Shut off valve closed. 4. Gas tank vent plugged. 5. If equipped with pulse pump-pulse line leaking or off. 6. Check pulse pump. 	<ol style="list-style-type: none"> 1. Refill tank. 2. Clean or replace fuel filter. 3. Open. 4. Clean out vent. 5. Install new pulse line. 6. If inoperative, replace.
Carburetor leaks.	<ol style="list-style-type: none"> 1. Loose fuel line fitting. 2. Carb float setting set too high. 	<ol style="list-style-type: none"> 1. Tighten fuel line. 2. Adjust float.
Engine starts but runs rough with low power output.	<ol style="list-style-type: none"> 1. High or low speed mixture adjustments off. 2. Incorrect float setting. 3. Dirty air filter. 4. Carburetor loose on engine block. 	<ol style="list-style-type: none"> 1. Readjust carburetor. 2. Adjust float. 3. Install new air filter. 4. Tighten carburetor mounting screws.

SERVICING

TYPICAL FUEL FLOW DIAGRAM

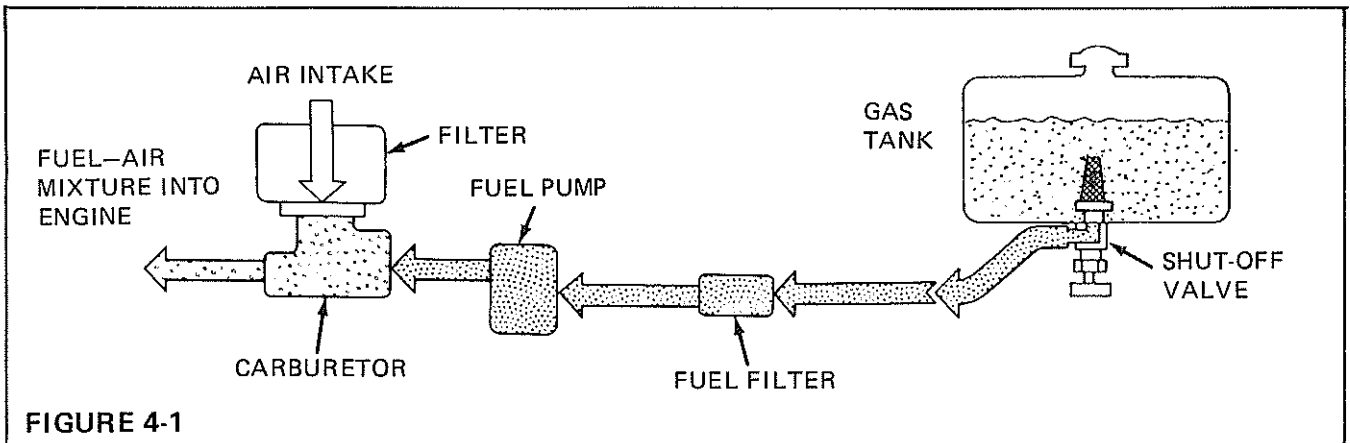

FUEL TANK

Fill with a good grade of clean, fresh regular or unleaded gasoline. (For cold weather operation, use winter blend gasoline.)



CAUTION

DO NOT MIX OIL WITH GASOLINE. REFUEL OUTDOORS WITH ENGINE STOPPED AND COOL.

Check to see that vent hole in fuel tank cap is not plugged.

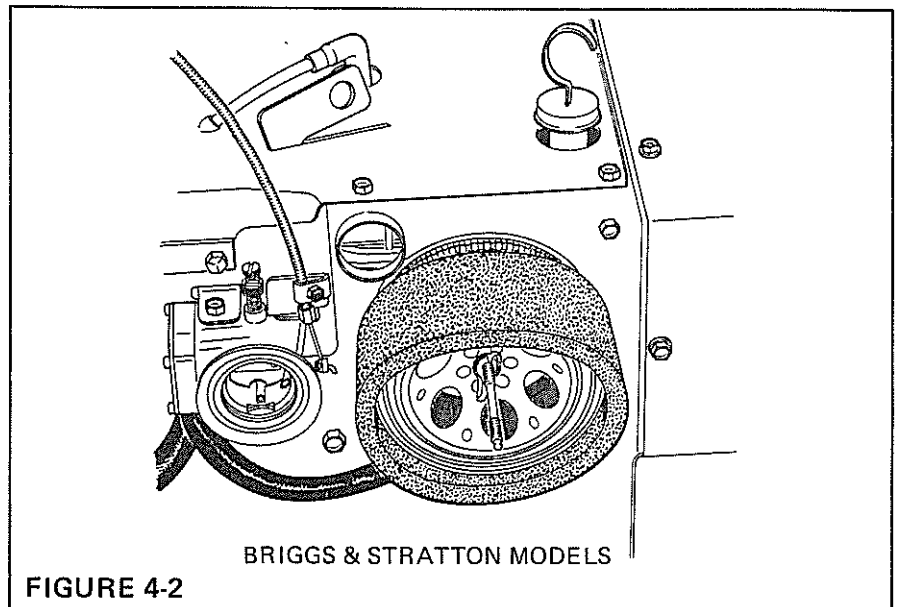

FUEL VALVE

The fuel valve is located under the fuel tank as shown in Figure 4-1. This valve must be fully open for proper operation of the tractor.

FUEL FILTER

The fuel filter is located in the fuel line near the engine. The fuel filter is a disposable type in-line filter, that should be replaced when dirty. To replace, shut off the valve under the fuel tank. Remove the filter from the fuel line and replace with a new one.

AIR CLEANER

The importance of maintaining an air cleaner in proper condition cannot be over-emphasized!

Improper air cleaner maintenance can create engine damage which the engine manufacturer will not warrant.

When servicing the air cleaner, lower the hinged side panel. Unscrew the wing nut on the air cleaner cover and remove. Clean the filter as follows:

BRIGGS & STRATTON 11 H.P. AIR CLEANER (Figure 4-2)

The air filter on the Briggs and Stratton engine has a precleaner.

This is cleaned by washing with a liquid detergent and water and squeezing dry like a sponge. After the precleaner is dry, put 1 oz. (.03 liter) of oil on it and squeeze to distribute oil evenly.

NOTE: DO NOT OIL ELEMENT. THE PAPER ELEMENT WILL BE DAMAGED.

SERVICING

Wipe dirt or dust accumulation from cover, including base plate. Dry type elements should be cleaned or replaced after 100 hrs, or once a year.

The dry element is cleaned by gently tapping on a flat surface to remove loose dirt.

BRIGGS & STRATTON TWIN CYLINDER AND VANGUARD AIR CLEANER (Figure 4-3 and 4-4)

Clean and re-oil foam pre-cleaner at three month intervals or every 25 hours, whichever occurs first.

NOTE

Service air cleaner more often under dusty conditions.

1. Remove knob and cover.
2. Remove foam pre-cleaner by sliding it off the paper cartridge.
3. a. Wash foam pre-cleaner in liquid detergent and water.
b. Wrap foam pre-cleaner in cloth and squeeze dry.
4. Reinstall foam pre-cleaner.

For Vanguard:

- a. Install pre-cleaner in cover with foam toward cover.
- b. Install cartridge in cover with tabs on cartridge in slots of cover.

5. Reassemble cover and screw down tight.

Yearly or every 100 hours, whichever occurs first, remove paper cartridge. (Service more often if necessary.) Clean by tapping gently on flat surface. If very dirty replace cartridge, or wash in a low or non-sudsing detergent and warm water

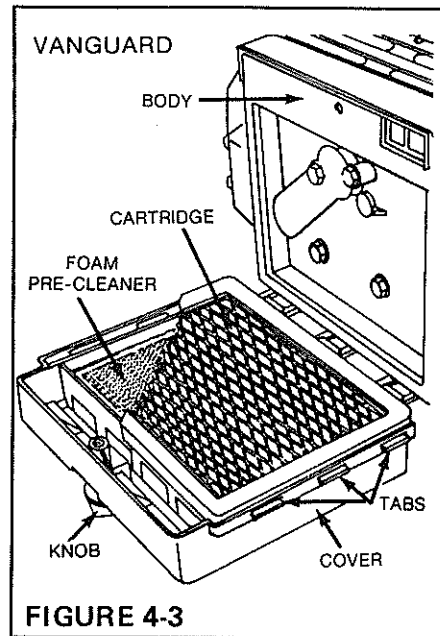

FIGURE 4-3

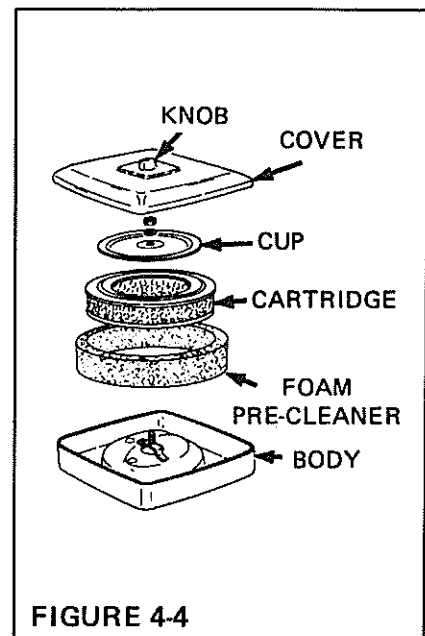

FIGURE 4-4

solution. Rinse thoroughly with flowing water from inside out, until water is clear. Cartridge must be allowed to stand and air dry thoroughly before using.

SERVICING

TECUMSEH AIR CLEANER (Figure 4-5)

Under normal operating conditions, disassemble and service air cleaner components every 100 hours of operation. Do this more frequently if extremely dust or dirty conditions prevail. The dry type element is cleaned by gently tapping on a flat surface - when doing this, be careful not to damage gasket surfaces on element.

DO NOT OIL ELEMENT. THE PAPER ELEMENT WILL BE MATERIALLY AFFECTED BY THEIR USE. USE ONLY A TECUMSEH ELEMENT.

Wipe dirt or dust accumulation from cover, and base plate. Dry type elements should be replaced when no longer serviceable.

TECUMSEH MODELS

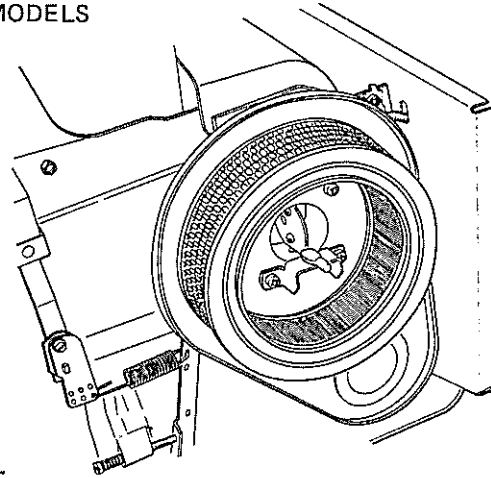

FIGURE 4-5

CARBURETOR

Carburetor is adjusted at the factory and should not have to be reset. If black exhaust is noted, check the air cleaner first. An "overrich" mixture is usually caused by a poorly serviced, and/or clogged air cleaner element, not an improperly adjusted carburetor.

BRIGGS & STRATTON CARBURETOR ADJUSTMENT (11 H.P.) (Figure 4-6 & 4-7)

Start engine and allow to warm up at 3000 RPM. Turn needle valve in until engine misses (lean mixture); then turn it out past smooth operating point until engine runs unevenly (rich mixture). Turn needle valve to the

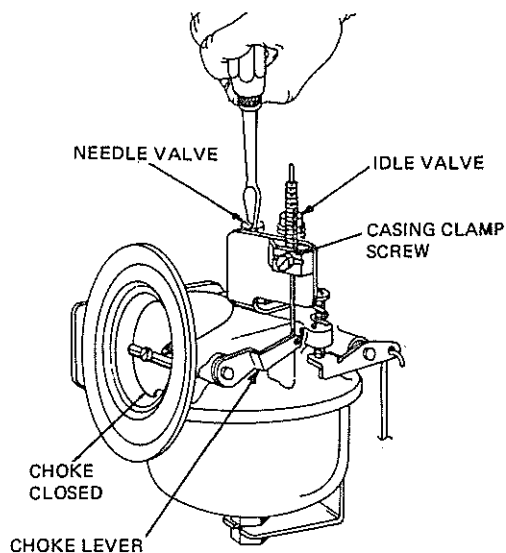

FIGURE 4-6

SERVICING

mid-point between rich and lean so engine runs smoothly. Set throttle in idle position and set idle speed adjusting screw, Figure 4-7, behind bracket until engine idle speed is 1750 RPM. With throttle in idle position, turn idle valve, Figure 4-6, in (lean) and out (rich) until engine runs smoothly. If necessary, correct idle speed. Move throttle up to fast - engine should accelerate without hesitation or sputtering. If engine does not accelerate properly, the carburetor should be readjusted, usually to a slightly richer mixture of the needle valve.

NOTE: IF THE NEEDLE VALVE OR IDLE VALVE BOTTOMS ON THE SEAT WHEN MAKING THE ABOVE ADJUSTMENTS, DO NOT FORCE FURTHER; THIS WOULD DAMAGE THE VALVE OR SEAT.

TO CHECK OPERATION OF CHOKE

1. Remove air cleaner to permit view of choke.

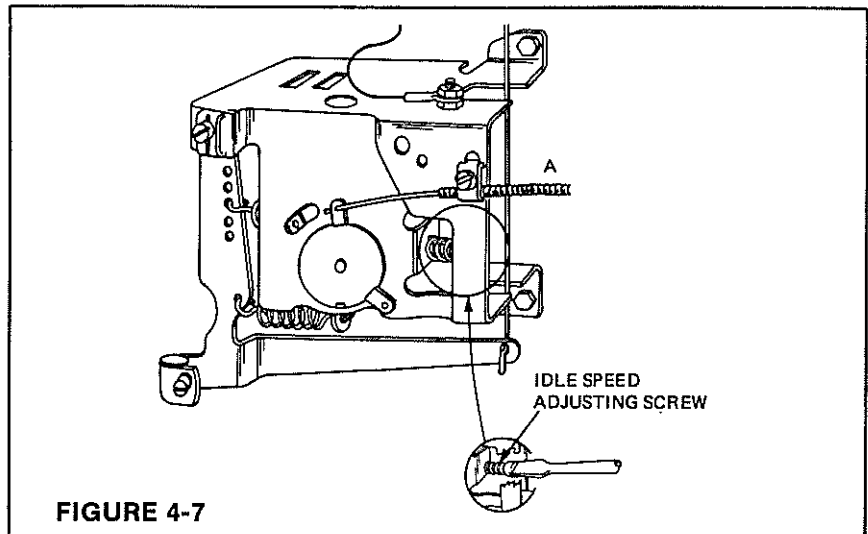

FIGURE 4-7

2. Move choke control lever to CHOKE position. The carburetor choke should be completely closed.
3. Reassemble air cleaner.

TO ADJUST CHOKE

Place choke control lever in CHOKE position. Loosen control casing clamp screw. Move casing and wire until choke is completely closed. Re-tighten casing clamp screw.

4

SERVICING

BRIGGS & STRATTON I.C. TWIN CYLINDER 14 HP & 16 HP Carburetor (Fig. 4-8 thru 4-10)

Minor carburetor adjustment may be required to compensate for differences in fuel, temperature, altitude or load.

THE TWIN CYLINDER ENGINE CARBURETOR FUEL MIXTURE ADJUSTMENT PROCEDURE IS UNIQUE. ADJUST CARBURETOR FUEL MIXTURE IN THE ORDER STATED AS FOLLOWS.

Turn the high speed mixture valve clockwise until it just closes. **CAUTION:** Valves may be damaged by turning them in too far. Open needle valve 1-1/2 turns counterclockwise. Close the idle mixture valve in the same manner, and open it 1-1/2 turns. This initial adjustment will permit the engine to be started, and warmed up prior to final adjustment.

NOTE: All carburetor adjustments must be made with air cleaner on engine.

Start engine and place equipment speed control lever in idle position. Hold carburetor throttle lever against idle stop, and adjust idle speed screw to obtain approximately 1400 RPM. Turn idle mixture valve slowly clockwise (lean mixture) until engine misses or speed drops. Then turn idle mixture valve 1/2 turn counterclockwise. Place equipment speed control lever in fast position. Turn high speed mixture valve slowly clockwise (lean mixture) until engine misses or speed drops. Then turn high speed mixture valve 1/2 turn counterclockwise.

If the engine does not accelerate properly, re-adjust high speed mixture valve approximately 1/8 turn counterclockwise (rich).

CONTROL ADJUSTMENTS

Proper choke and speed control operation is dependent upon proper adjustment of remote controls on the powered equipment.

TO CHECK OPERATION OF CHOKE CONTROLS:

Move remote control lever to "choke" position. The carburetor choke should be closed.

TO ADJUST CHOKE:

Place remote control lever on equipment in "CHOKE" position. Loosen control casing clamp screw. Move control casing and wire until choke is completely closed. Tighten casing clamp screw.

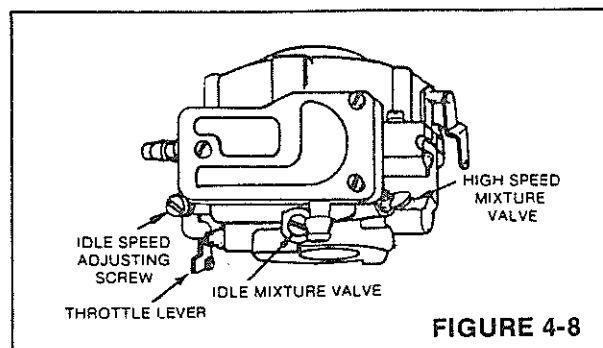

FIGURE 4-8

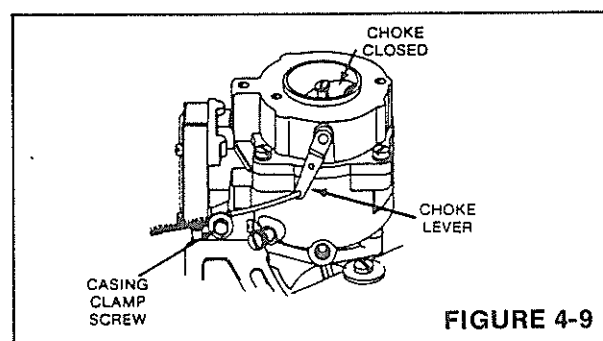

FIGURE 4-9

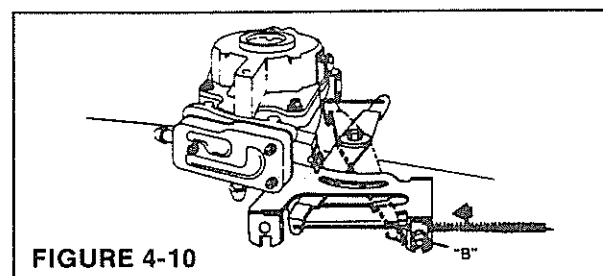

FIGURE 4-10

GOVERNOR SPEED CONTROL ADJUSTMENT

The acceptable operating speed range is 1800 to 3600 RPM. Idle speed is 1400 RPM. The manufacturer of the equipment on which the engine is used, specifies the top governed no load speed at which the engine may be operated. **DO NOT EXCEED** this speed.

Engine speed is controlled by movement of the control lever. Move control lever on equipment, "A", to slowest engine speed possible. Throttle lever on carburetor should touch idle speed adjusting screw. To adjust, loosen control casing clamp screw "B". Move control casing and wire in direction shown by arrow until throttle lever touches idle speed adjusting screw on carburetor. Retighten casing clamp screw "B".

CAUTION: Throttle lever on carburetor **MUST** touch idle speed adjusting screw when equipment control lever is in slowest position.

SERVICING

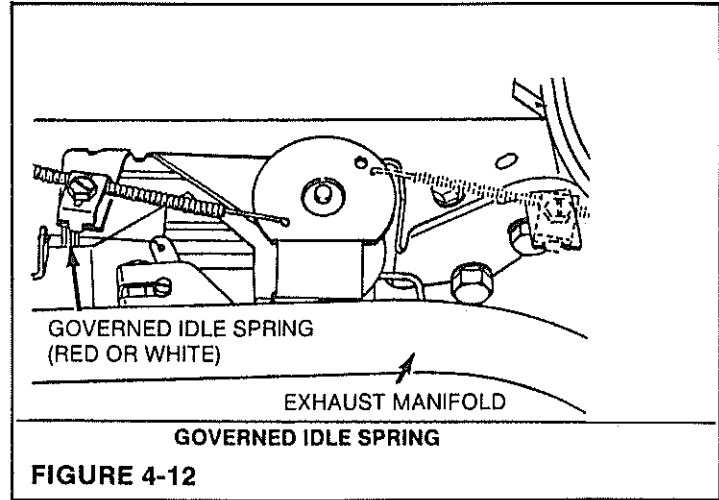
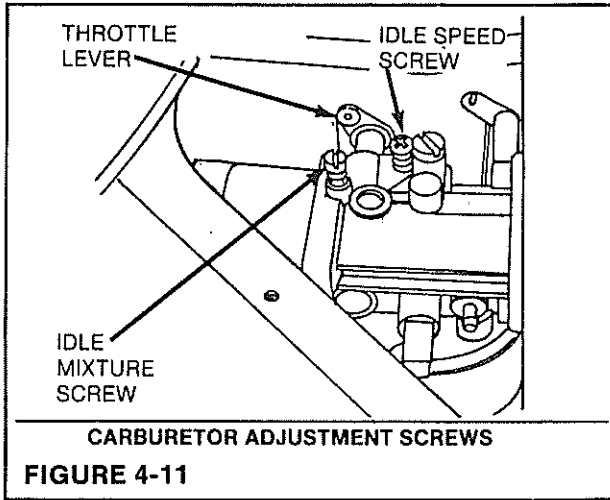

BRIGGS & STRATTON VANGUARD CARBURETOR (Figure 4-11)

CARBURETOR ADJUSTMENTS

Minor carburetor adjustment may be required to compensate for differences in fuel, temperature, altitude or load.

NOTE: The air cleaner and air cleaner cover must be assembled to carburetor when running engine.

THE TWIN CYLINDER ENGINE CARBURETOR FUEL MIXTURE ADJUSTMENT PROCEDURE IS UNIQUE. ADJUST CARBURETOR FUEL MIXTURE IN THE ORDER STATED AS FOLLOWS:

INITIAL ADJUSTMENT (Figure 4-11)

Gently turn the idle mixture screw clockwise until it **just** closes. Screw may be damaged by turning it in too far. Then turn idle mixture screw 1-1/2 turns counterclockwise.

This initial adjustment will permit the engine to be started and warmed up (approximately 5 minutes) prior to final adjustment.

FINAL ADJUSTMENT (Figure 4-11 & 4-12)

Start engine and place equipment speed control lever in idle position. Hold carburetor throttle lever against idle stop and adjust idle speed screw to obtain 1300 to 1500 RPM. Turn idle

mixture screw **slowly** clockwise (lean mixture), until speed **just** starts to slow. Then turn idle mixture **screw** slowly counterclockwise (rich mixture) until **speed** just starts to slow. Turn screw to midpoint between rich and lean. Now adjust idle spring screw to obtain 1200 RPM, if governed idle spring is red, or 900 RPM, if governed idle spring is white. Release throttle lever.

If the engine does not accelerate properly, readjust idle mixture screw approximately 1/8 turn counterclockwise (rich).

NOTE: Engines operated at altitudes of approximately 3000 to 5000 feet (900 to 1500 meters) or higher, may require the installation of a high altitude carburetor main jet to achieve best engine performance. If erratic performance is observed, contact a Briggs & Stratton Authorized Service Center for part number of high altitude jet.

CONTROL ADJUSTMENTS

Proper choke and throttle control operation is dependent upon proper adjustment of equipment controls.

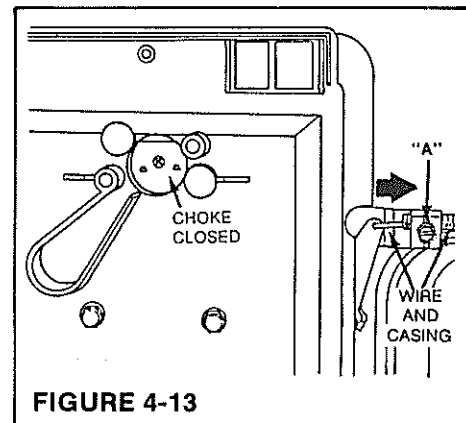

TO CHECK OPERATION OF CHOKE CONTROL:

Move choke control to "CHOKE" position. The carburetor choke should be closed.

CHOKE CONTROL ADJUSTMENT (Figure 4-13)

Loosen casing clamp screw "A". Move choke control to "CHOKE" position. Move casing and wire in direction of arrow until choke is completely closed. Retighten casing

4

SERVICING

THROTTLE CONTROL CHECK (Figure 4-14)

Move control lever on equipment to fastest speed position. Swivel on control bracket should be against stop, "B".

THROTTLE CONTROL ADJUSTMENT (Figure 4-14)

Loosen casing clamp screw "A". Move casing and wire in direction shown by arrow until swivel contacts stop "B". Retighten casing clamp screw "A".

ADJUSTABLE GOVERNOR CONTROL:

The manufacturer of the equipment on which this engine is installed set the speed at which it operates. If adjustment is required, consult any Briggs & Stratton Authorized Service Center.

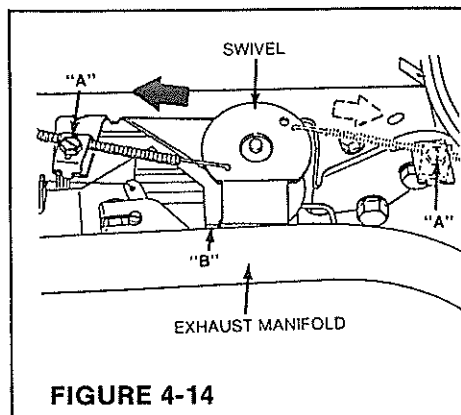

FIGURE 4-14

TECUMSEH CARBURETOR ADJUSTMENT

Turn the IDLE fuel adjusting screw, Figure 4-15, all the way in until it bottoms lightly; do not force it closed as this will damage the needle valve. For preliminary setting, turn IDLE fuel screw out (counterclockwise) 1-1/2 turns.

For final adjustments, start engine and allow it to warm up, then operate at full throttle and under load if possible. If engine runs rough, turn IDLE fuel screw either direction in 1/8th turn increments until engine runs smooth. Allow engine to run a couple of seconds between each setting before adjusting again. Rough idle is often due to the idle speed being set too low - check this also.

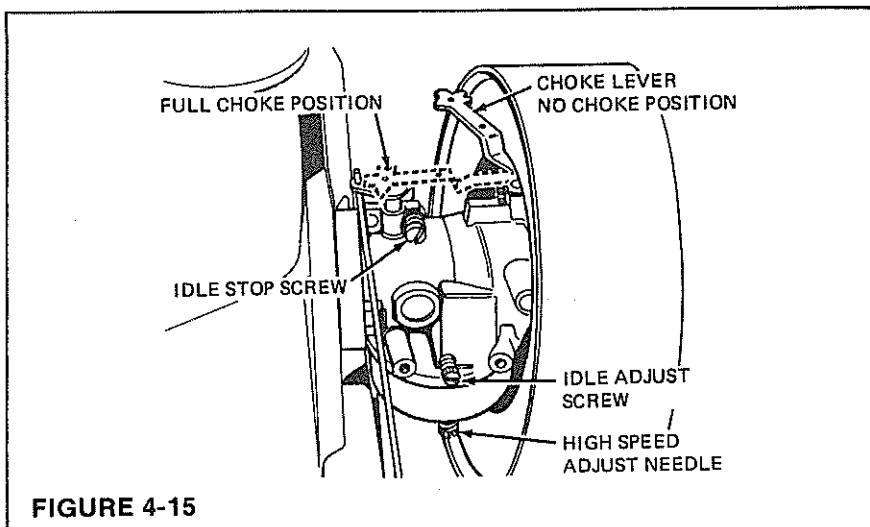

FIGURE 4-15

**WHO HAS THE PROPER
EQUIPMENT AND EXPERIENCE
TO MAKE ANY NECESSARY
ADJUSTMENTS.**

**CHANGING OF ENGINE
GOVERNED SPEED WILL VOID
ENGINE WARRANTY.**

**NEVER TAMPER WITH ENGINE
GOVERNOR WHICH IS
FACTORY SET FOR PROPER
ENGINE SPEED. OVER-
SPEEDING ENGINE ABOVE
FACTORY HIGH SPEED
SETTING CAN BE DANGEROUS.
IF YOU THINK THE ENGINE
GOVERNED HIGH SPEED
NEEDS ADJUSTING, CONTACT
YOUR NEARBY AUTHORIZED
TECUMSEH SERVICE OUTLET,**

GENERAL TRACTOR ADJUSTMENTS

FRONT WHEEL ALIGNMENT

1. Turn steering wheel so that front wheels are straight ahead.
2. Measure distance across front of front tires, center line to center line. Measure distance across rear of front tires, center line to center line. Distance at the front of tires should be 1/8 inch to 3/8 inch (3-9.5 mm) less than the rear of tires. If adjustment is necessary, remove the rod end from spindle. Loosen jam nut (A) and turn in or out as necessary. Adjust each side equally.
3. After adjustment is obtained tighten hex nuts securely.
4. With arm (B) positioned approximately 15° to the rear, adjust drag link (C) till wheels are parallel to the centerline of the tractor.

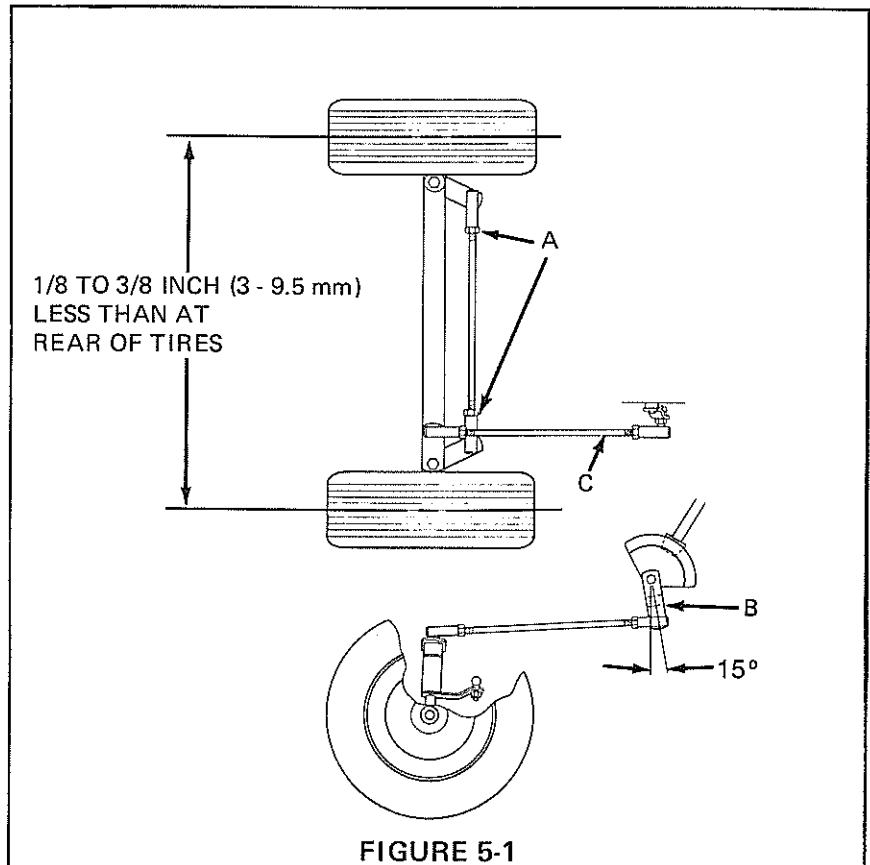

STEERING ASSEMBLY

If any repair work is needed on the Steering Assembly, follow the instructions below.

Disassembly:

1. Remove retaining ring (D) Figure 5-2 and slide the steering arm shaft out.

NOTE: If further disassembly is needed drag link (E) must be disconnected.

NOTE: Keep track of all shims and their locations when disassembling.

2. Disassemble the steering wheel by removing roll pin (E), Figure 5-3 and washer.

3. Remove the steering shaft assembly from the steering column.

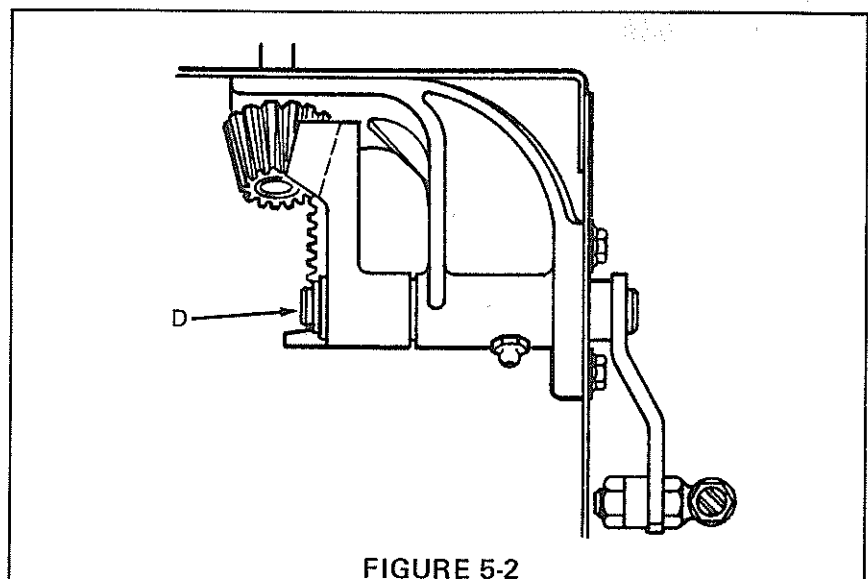

STEERING ASSEMBLY (CONT'D)

NOTE: It may be necessary to tap the steering shaft down until flange bushing (F) is pushed out of the steering support casting.

REASSEMBLY:

1. With flange bushing (F) slid onto the pinion shaft assembly, route it through the casting and through the steering column bearing. Slide on any needed shims at point (G) and secure the steering wheel with the roll pin (E) removed earlier.

2. With the steering wheel emblem right side up position steering gear (H) in steering casting.

3. With the steering arm pointed about 10° to the rear, (See Figures 5-1 and 5-3), slide it through the steering casting, and reinstall the shims removed earlier and steering gear (H) Figures 5-3.

4. If for some reason the two gears do not have maximum engagement, shim at point (I) and secure with retaining ring (D), Figure 5-2.

5. Turn steering wheel to check for binding.

PNEUMATIC TIRES

Keep both front and rear tires inflated evenly. Under no circumstances should tire inflation be less than 8 pounds, (55 kPa) no more than 12 pounds (82 kPa). Check air pressure with a low pressure gauge. Operating with incorrect pressures may damage tires.

CLUTCH ADJUSTMENT (Gear Driven Models Only)

The clutch generally should not require any adjustment. If for any reason the clutch is not disengaging or engaging correctly, adjust as follows:

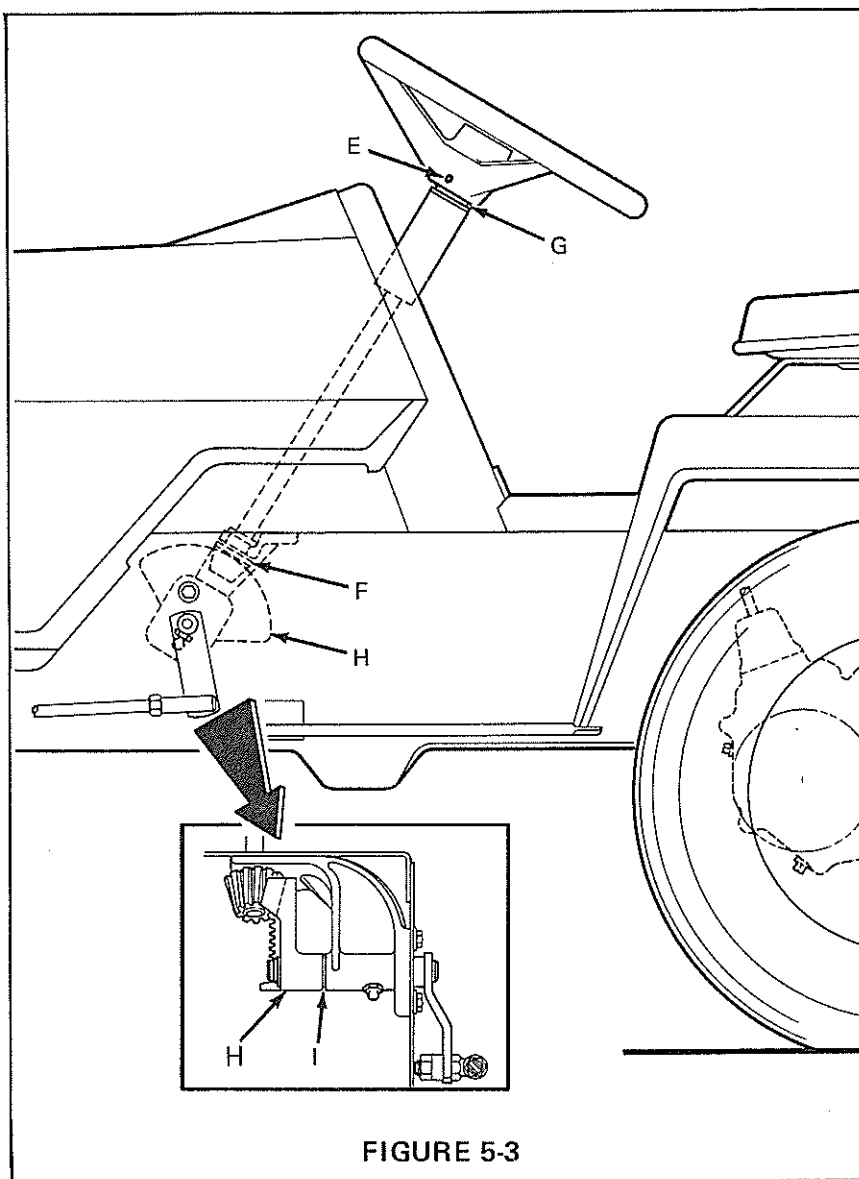

FIGURE 5-3

(Early Models)

When foot pedal has fully returned to its upper position, screw on lock nut (A), Figure 5-4 until there is a gap of 1/8 inch (3 mm) between spring (B) and lock nut (A).

(Later Models)

When foot pedal has fully returned to its upper position, screw on lock nut (A), Figure 5-4A, till there is a gap of 1/8" (3 mm) between pivot block (B) and lock nut (D).

With the foot pedal depressed and the engine at full speed, the drive belt should not rotate. If it does, adjust lock nut (A) or check belt guides.

GEAR DRIVE TRACTOR ADJUSTMENTS

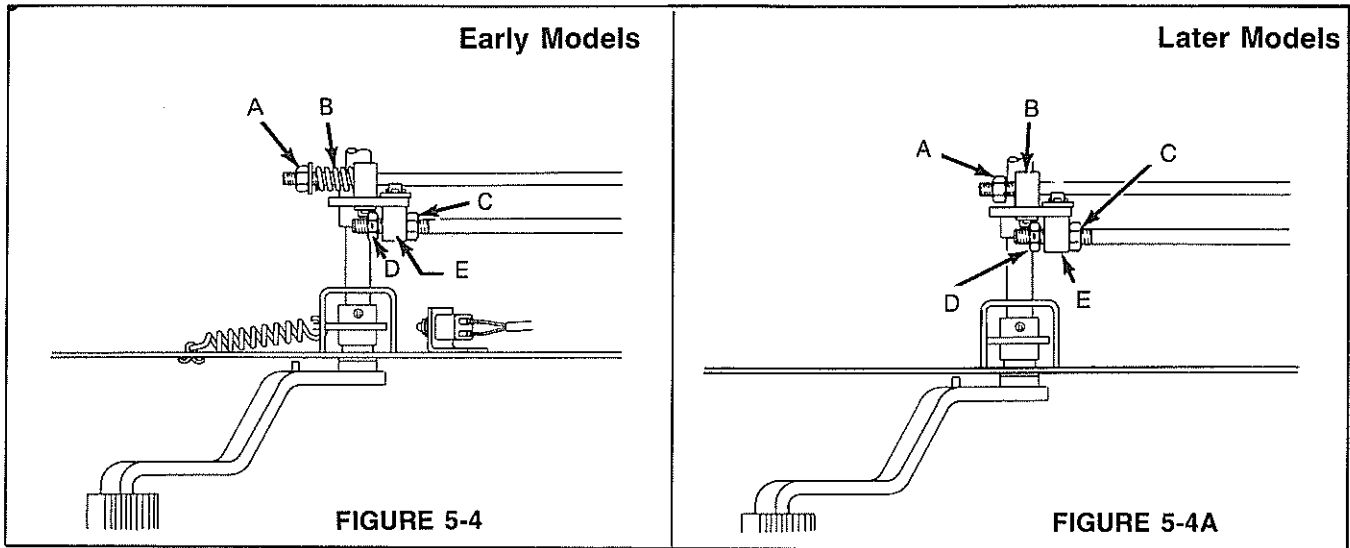

BRAKE ADJUSTMENT (Figure 5-4 and 5-4A)

When the brake will no longer hold the tractor with brake lock set in the third or lowest notch, the brakes should be adjusted. To adjust, loosen nut (C) on brake rod.

With the foot pedal returned to its uppermost position, adjust lock nut (D) till there is a gap of 1/16" (1.5 mm) between lock nut and pivot block (E). Tighten nut (C) to pivot block.

BELT GUIDES ADJUSTMENT (Figure 5-5)

With the foot pedal in its uppermost position check belt guides as follows:

1. Belt guide (F) on right angle drive support should be 1/16 in. (1.5 mm) away from belt.
2. Guide (G) at idler should be in approximate position shown in Figure and 1/8" (3 mm) away from belt.
3. Belt guides (H) should be adjusted 3/32 in. (2 mm) away from drive belt.

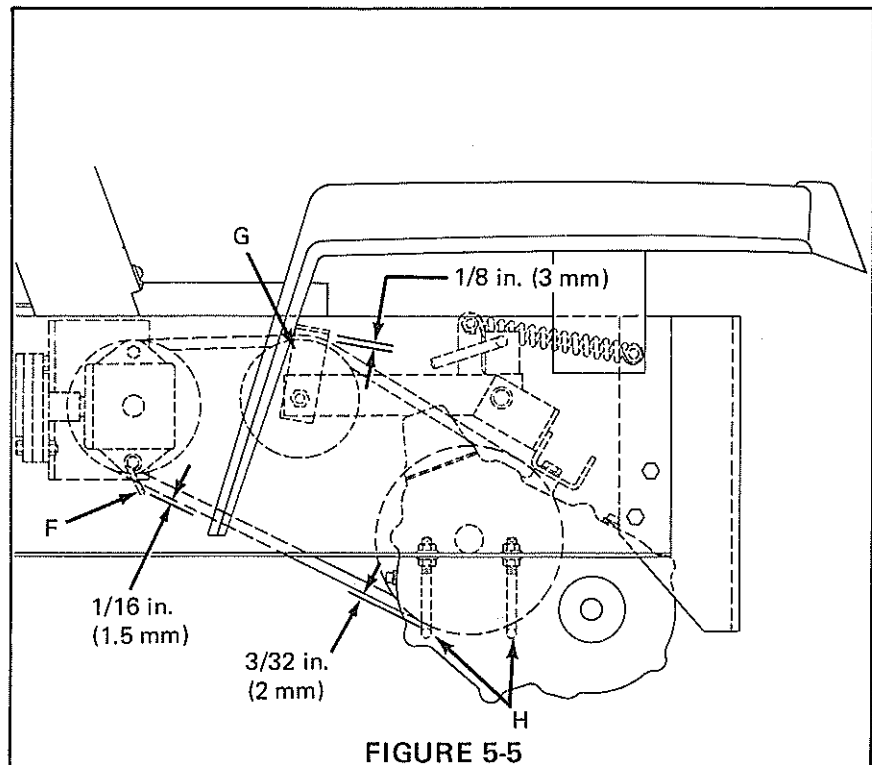

HYDROSTATIC TRACTOR ADJUSTMENTS

Below is a view of the Hydrostatic control linkage for the hydrostatic drive tractors. Study, then proceed with the instructions.

1468, 1669, 1669L

1458, 1658, S/N 0300101 AND UP

1258, 1659, 1664, 1668, 1858 S/N 0100101 AND UP

1058, 1458-1658 S/N 0100101-0299999

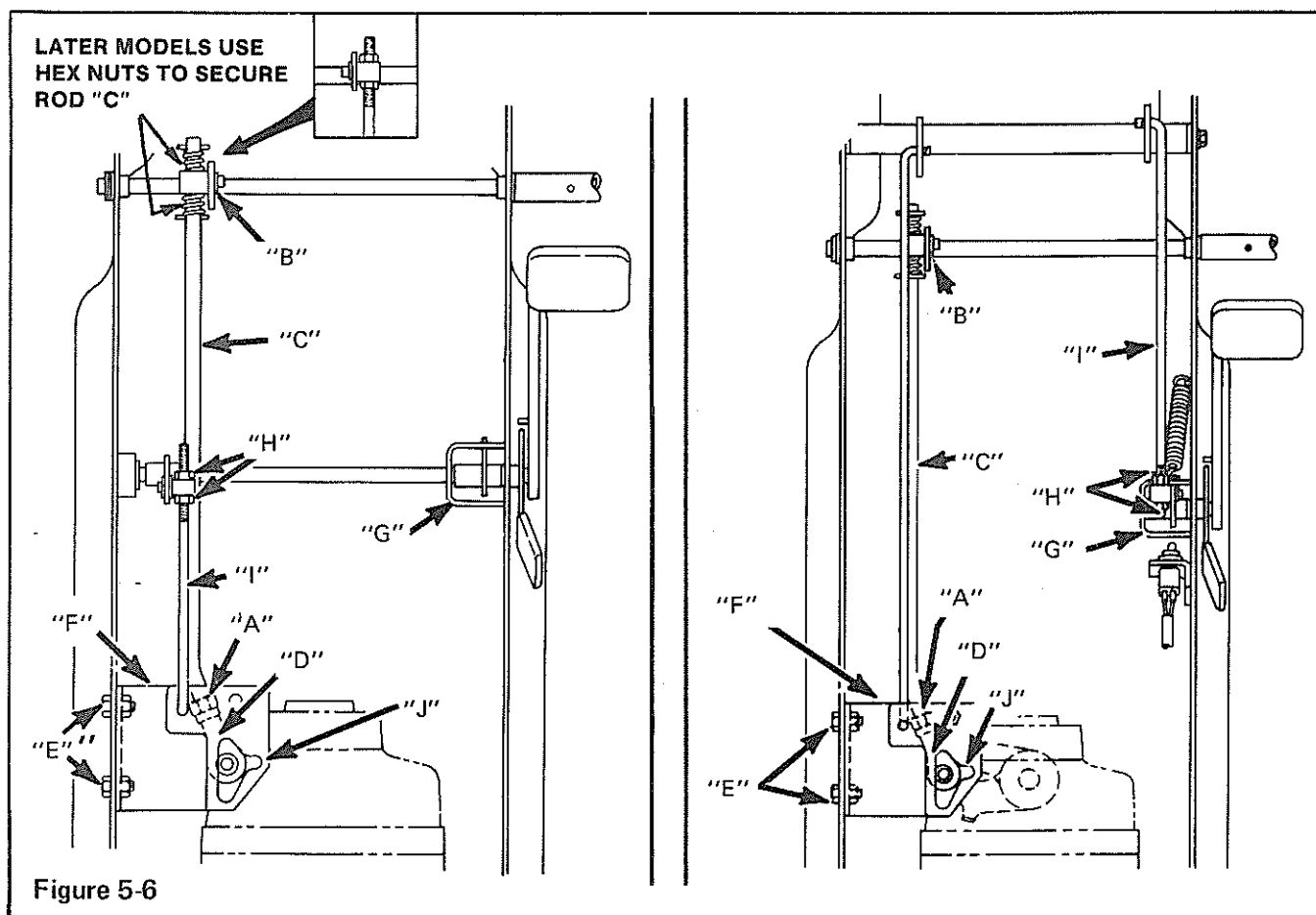

HYDROSTATIC PEDAL ADJUSTMENT (Figure 5-6)

The Pedal was adjusted at the factory with its tip approximately 45° forward of vertical. If the operator would prefer to either increase or decrease this angle for personal comfort, the pedal can be adjusted as follows:

1. Loosen hex nut (A).
2. (Not required on 1458-01). Remove cotter pin (B) and remove pivot block from control arm.
3. Turn rod (C) into rod end (D) to increase the pedal angle. Turn rod out to decrease the pedal angle.

4. Replace pivot block cotter pin. Retighten hex nut (A), against rod end (D).

HYDROSTATIC NEUTRAL ADJUSTMENT (Figure 5-6)

The Hydrostatic neutral is adjusted at the factory. If the transmission should need

adjustment, the following procedure should be used.

With the transmission cold and engine off, check the fluid in transmission reservoir. It should be to the level indicated on dipstick.

Start engine and release parking brake. If the tractor creeps Forward or Backwards, the Neutral position needs adjustment.

Adjust Neutral as follows:

1. Securely block up rear of tractor, just so the rear wheels clear the ground.
2. Start the engine and release the brake.
3. Loosen capscrews (E) and move support plate (F) Forward if wheels rotate in forward direction, or toward the rear if wheels rotate in reverse.
4. Tighten capscrews securing support plate when wheels no longer rotate.
5. Stop engine and lock brake arm against the stop (G).
6. Loosen jam nuts (H) and move rod (I) until pin lightly contacts slot (J) of neutral plate.

NOTE: EXCESSIVE ADJUSTMENT MAY CAUSE PIN BREAKAGE.

7. Tighten jam nuts (H).

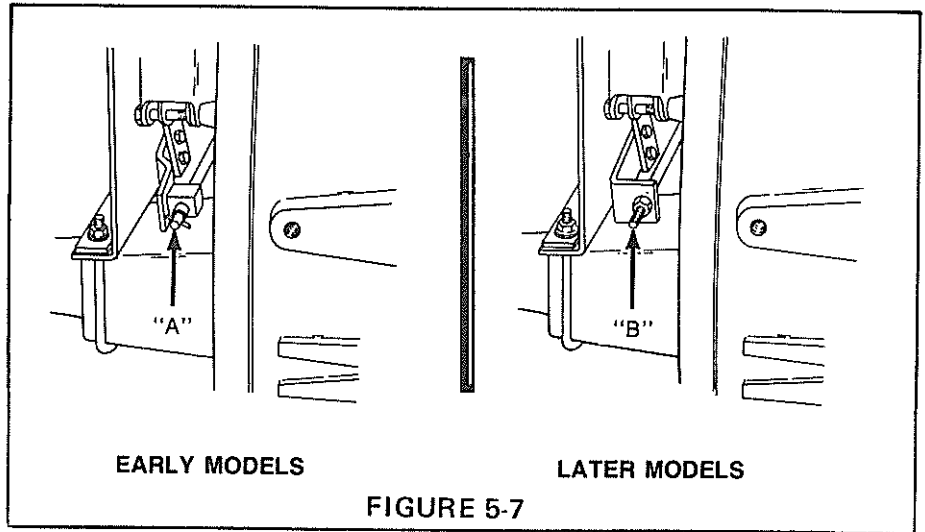

BRAKE ADJUSTMENT (Figure 5-7)

If only light foot pressure is required to latch the parking brake, or if the parking brake does not hold the tractor when the brake pedal is latched, the brake system requires adjustment.

With the parking brake released, proceed as follows:

Turn brake rod (A) or hex nut (B) until a gap of .010 (0.25 mm) is achieved between brake disc and brake pad.

With brake pedal fully released, brake disc must rotate freely.

The tractor should not move when the brake is locked in the FIRST position.

SEAT ADJUSTMENT

(1458-01 Model only)

To adjust seat, remove the two rear capscrews (A) Figure 5-8. Loosen the two front capscrews (B) and reposition seat by sliding either forward or backward.

Tighten front capscrews and reinstall rear capscrews to secure seat in its new position.

(ALL MODELS EXCEPT 1458-01)

To adjust seat, loosen knobs (G) Figure 5-9 beneath seat and slide seat forward or back. For different spring suspension, twist spring (H) to loosen. Slide spring to the front for light operators or back for heavy operators. Twist spring to tighten.

EARLY MODELS (1258, 1261, 1458, 1461, 1658, 1661 & 1858)

To keep seat in a upright position, turn arm (D) down to act as a brace for the seat.

INTERLOCK SWITCHES

This unit is equipped with INTERLOCK SAFETY SWITCHES. The function of these safety switches is to insure SAFE START-UP of the unit.

1. One interlock switch is incorporated into the Attachment Drive Switch.

(ALL MODELS EXCEPT 1458-01) (Figure 5-9)

2. The second switch is below the seat, (A), Figure 5-9. This switch should be activated when back edge of seat support (B) is depressed $5/8$ " (16 mm). If not, loosen bracket (C) and move to correct location. The switch can also be activated by raising the seat and lifting the interlock button UP.

3. The third switch (E), Figure 5-10, is on the brake linkage. The switch button should depress approximately $3/32$ " (2 mm) when the brake is applied. If not, adjust by loosening nuts on switch and moving switch forward or back. Retighten nuts.

CRUISE SWITCH

4. The fourth switch (C) Figure 5-10 is also on the brake linkage. When the pedal is released the button of the switch should be depressed approximately $3/32$ " (2 mm). When the pedal is depressed, the button of the switch is released and all power to the cruise control is shut off. If not, adjust by loosening nuts on switch and move switch forward or back. Retighten nuts.

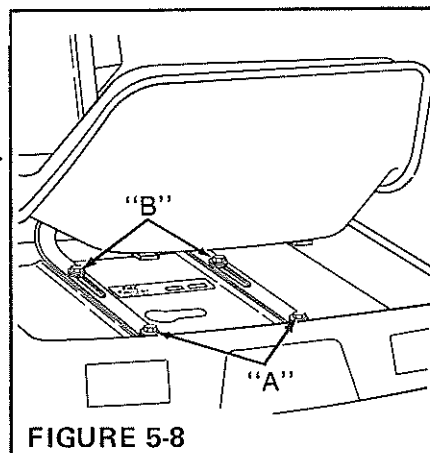

FIGURE 5-8

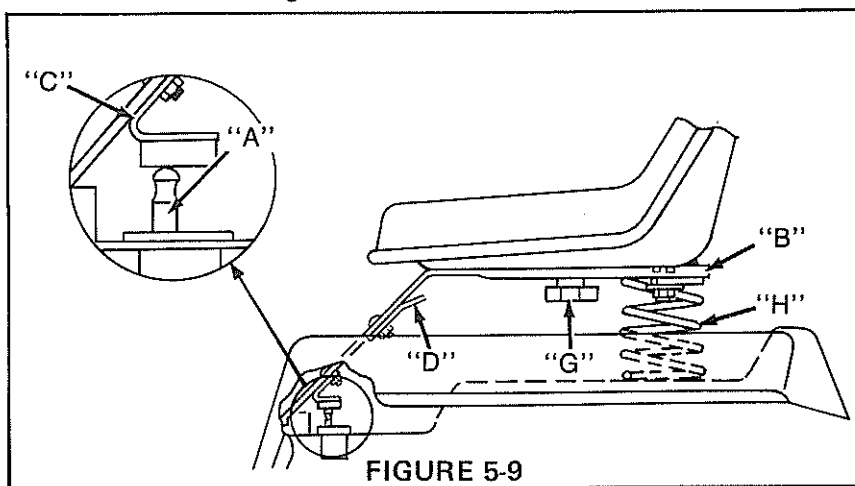

FIGURE 5-9

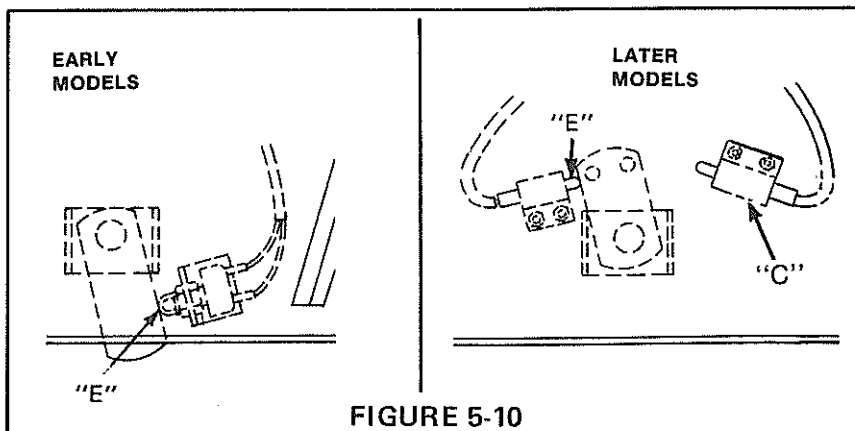

FIGURE 5-10

MOWER DRIVE ADJUSTMENT

To adjust the mower drive belt to its proper tension proceed as follows:

EARLY MODELS (FIGURE 5-11)

Turn hand knob (A) till indicator wire (B) is between the two lines of the decal on the side of the support.

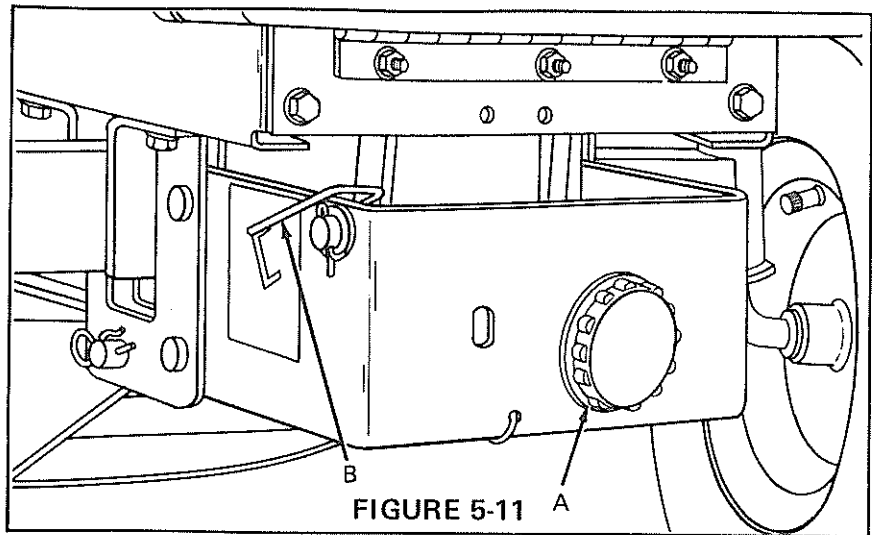

LATER MODELS (FIGURES 5-12 & 5-12A)

Turn hand knob (C) till indicators (D) are parallel to one another.

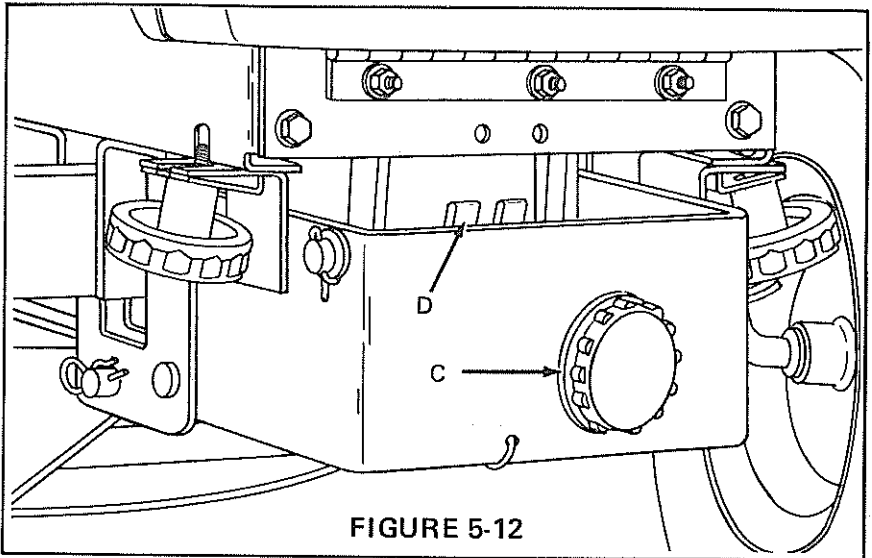

ALL MODELS

After the above adjustments the two idlers of the drive should be in line with each other.

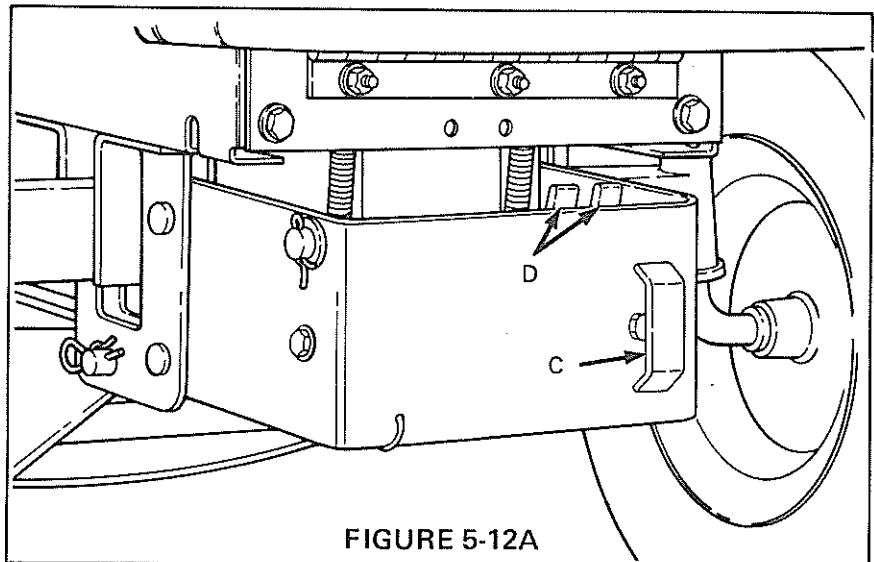

POWER TAKE-OFF (P.T.O.)

ELECTRIC CLUTCH

REMOVAL

NOTE: DO NOT USE WHEEL PULLER TO REMOVE CLUTCH/BRAKE.

Remove the hood and front frame cross plate.

Disconnect plug from clutch.

Remove four locknuts.

Remove mounting capscrew and washers from center of crankshaft.

On Model 1458 Serial Number 0100101 to 0199999, the engine must be removed to remove the electric clutch. On all other models, the electric clutch can be removed while in the frame.

Remove sheave and brake assembly. (See Figure 5-14).

Remove rotor assembly.

Remove four 3/8-16 x 3/4 flange lock capscrews securing coil assembly to crankcase.

Remove coil assembly from engine.

INSTALLATION

Position coil assembly on engine, piloting it in crankshaft seal bore. Secure with four 3/8-16 x 3/4 flange lock capscrews.

On Briggs and Stratton engines the coil assembly must be centered around pilot spacer (A), Figure 5-13. Center by feel. When mounting the assembly, a spacer must be used at all four capscrew locations.

Place compression springs Figure 5-14 on brake mounting studs.

Remove rust, burrs and dirt from engine shaft with emery cloth.

Apply light coat of grease or oil to shaft. Insert key into keyway in shaft.

Push rotor and armature assembly with pulley onto engine shaft until hub bottoms on crankshaft shoulder.

Place large washer and lockwasher on clutch mounting capscrew.

Install capscrew into tapped hole in center of crankshaft. Prevent clutch from rotating, tighten capscrew to 23-27 ft. lbs. (31-36 N-m) and torque.

Adjust brake as described under maintenance.

Reconnect plug lead to lead from switch making certain connection is secure and the wire is not rubbing against rotating parts.

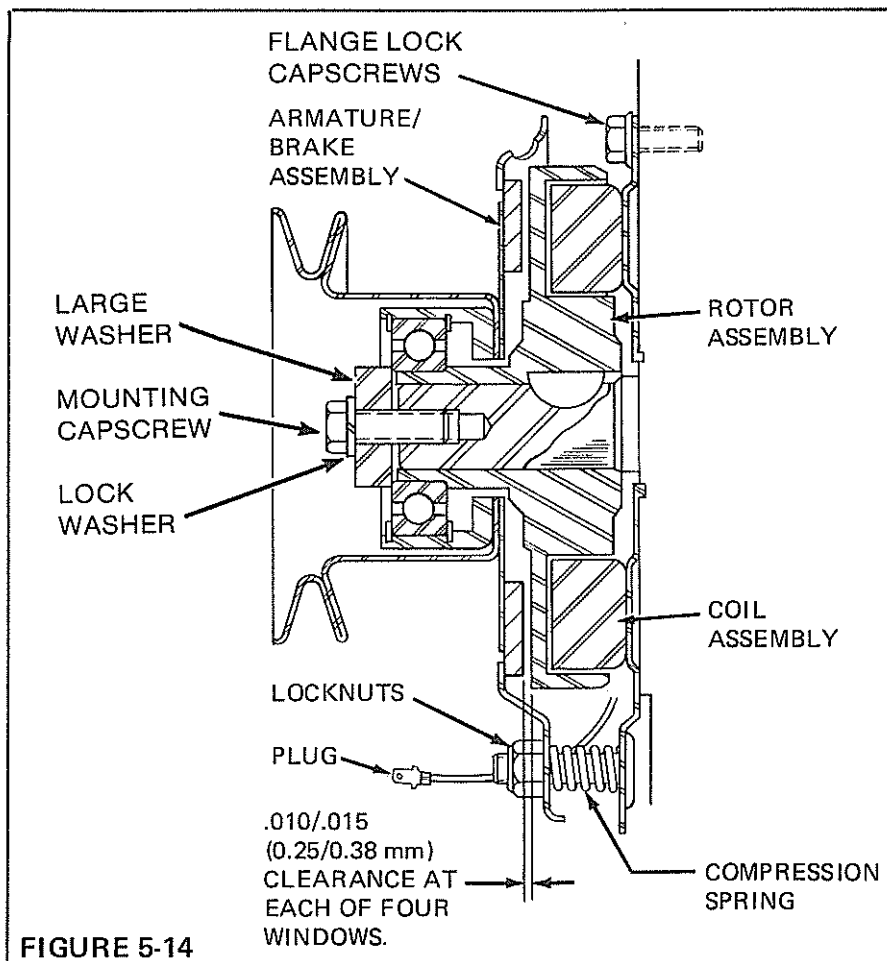
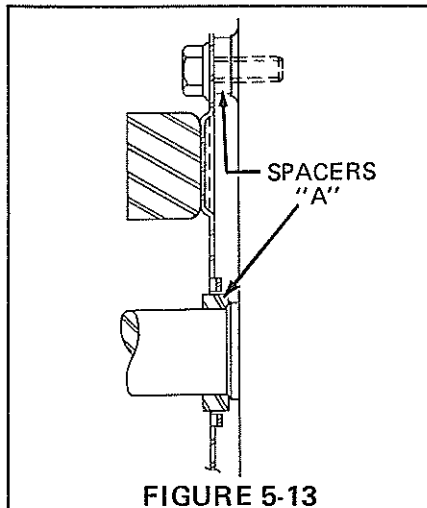

POWER TAKE-OFF (P.T.O.)

MAINTENANCE

Once the clutch/brake has been installed, the clutch portion requires no further maintenance. The unit is self-adjusting for wear and never requires lubrication.

The brake portion may require periodic readjustment depending upon unit usage. This can be accomplished as follows:

Position a .015" (0.38mm) thick shim in each of the four slots, Figure 5-15, in brake flange and turn on clutch/brake. Tighten the (4) locknuts until they just contact brake flange. (CAUTION: DO NOT over torque locknuts as damage to brake flange may result).

Turn off clutch/brake and remove (4) shims. Recheck gap through the slots provided. A minimum of .010" (0.25mm) and a maximum of .015" (0.38mm) should be maintained.

If oil or grease contaminate clutch working surfaces, remove with a cleaning fluid. (Barcothene alcohol or ammonia are acceptable substitutes). With engine off, pour a generous quantity of cleaning fluid between working surfaces.

If the clutch/brake has not been used over a long period of time, the following procedure is recommended prior to its use.

- a. Position tractor in neutral position.
- b. Start tractor engine, and put throttle in fast position.
- c. Turn clutch/brake switch on and off six times, engaging and disengaging driven attachments.

NOTE: ALLOW ENGINE DRIVEN ATTACHMENTS TO COME TO A COMPLETE STOP BETWEEN ON-OFF CYCLES.

The clutch/brake is now ready for continuous, trouble-free duty.

ELECTRIC P.T.O. CLUTCH SPECIFICATIONS

Voltage..... 12VDC
Resistance..... 2.8Ohms
Current..... Draw 4.17 Amps

TROUBLESHOOTING

Electrical Data - See wiring diagram in the electrical section of this manual.

- a. Clutch does not engage - Check electrical system for broken wires or bad connections. Check voltage at clutch lead. Voltmeter should read more than 10 volts. If voltmeter does not register a reading, look for broken wires or connect clutch lead and check

resistance reading of clutch coil A normal resistance reading should be between 3.0 and 2.3 ohms. A reading outside these values indicates a faulty coil. The field assembly should then be replaced. Check armature/rotor air gap. This is done by inserting a feeler gauge in the (4) slots provided in the brake flange. The gap should be between .010" - .015" (0.25 - 0.38mm) with the clutch/brake switch in the "off" position. If the gap is greater, readjust brake as described under maintenance.

- b. If engine driven attachment rotates slower than normal, check for loose belt. Inspect engine driven attachment with PTO belt removed. Attachment should turn freely. Check clutch/brake working surfaces for grease or oil.

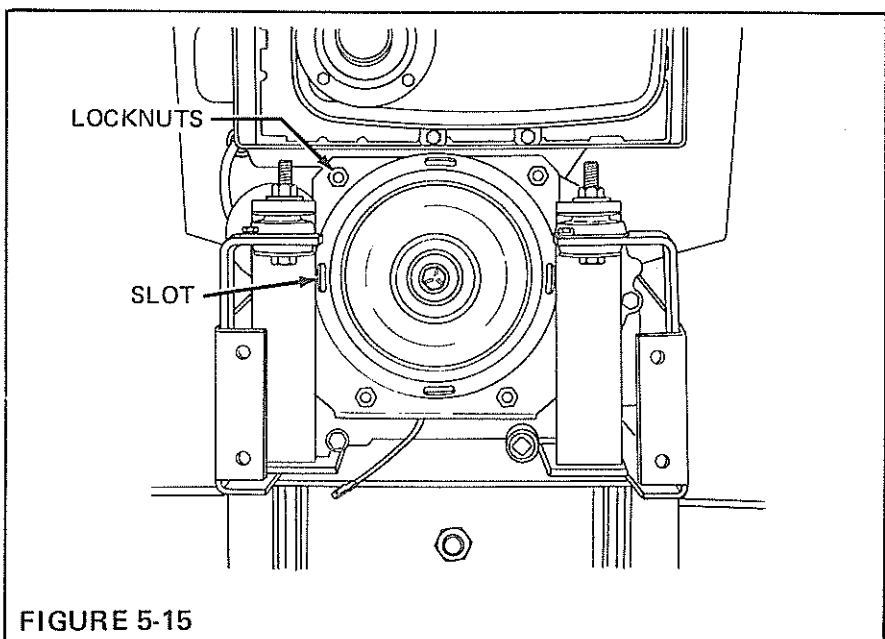

FIGURE 5-15

TROUBLE SHOOTING GUIDE

PROBLEM	PROBABLE CAUSE	REMEDY
Hydraulic lift inoperative	<ol style="list-style-type: none">1. System low on fluid.2. Oil line leaking.3. Malfunctioning lift valve.4. Malfunctioning lift cylinder.5. Low pressure from pump.6. Water or air in system.	<ol style="list-style-type: none">1. Check level at transmission dipstick.2. Replace line.3. Replace valve.4. Repair or replace cylinder.5. Repair or replace hydro charge pump.6. Change oil and/or check hydraulic connections.
Load drops when control valve is in neutral position.	<ol style="list-style-type: none">1. Leaky hose between valve and cylinder.2. Oil leaking past lift cylinder "O" rings.3. Lift valve leaking internally.	<ol style="list-style-type: none">1. Replace hose.2. Repair lift cylinder.3. Replace lift valve.
Lift valve or lift cylinder leaking.	<ol style="list-style-type: none">1. Leaking "O" rings.	<ol style="list-style-type: none">1. Replace "O" rings.
Hydraulic oil filter blowing.	<ol style="list-style-type: none">1. Plugged filter.2. Restriction between filter & hydro.	<ol style="list-style-type: none">1. Replace filter.2. Remove and inspect hydraulic lines & fittings.

PRINCIPLE OF OPERATION

The hydraulic system is made up of five major components. These are: the hydrostatic transmission charge pump, attachment lift valve, attachment lift cylinder, filter and all external lines and

hoses. The source of the fluid flow is a roller type charge pump mounted on the hydrostatic package, which is driven by the engine. This charge pump provides hydraulic pressure. The

fluid reservoir is the transmission and final drive housing. All flow is first routed through the attachment lift valve.

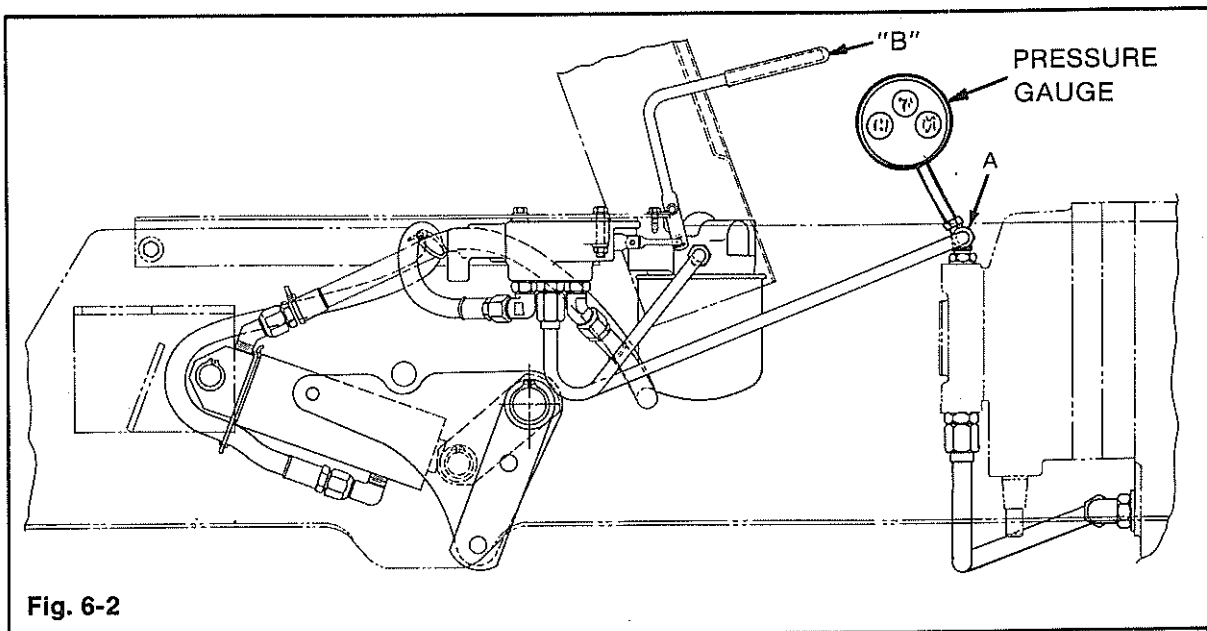
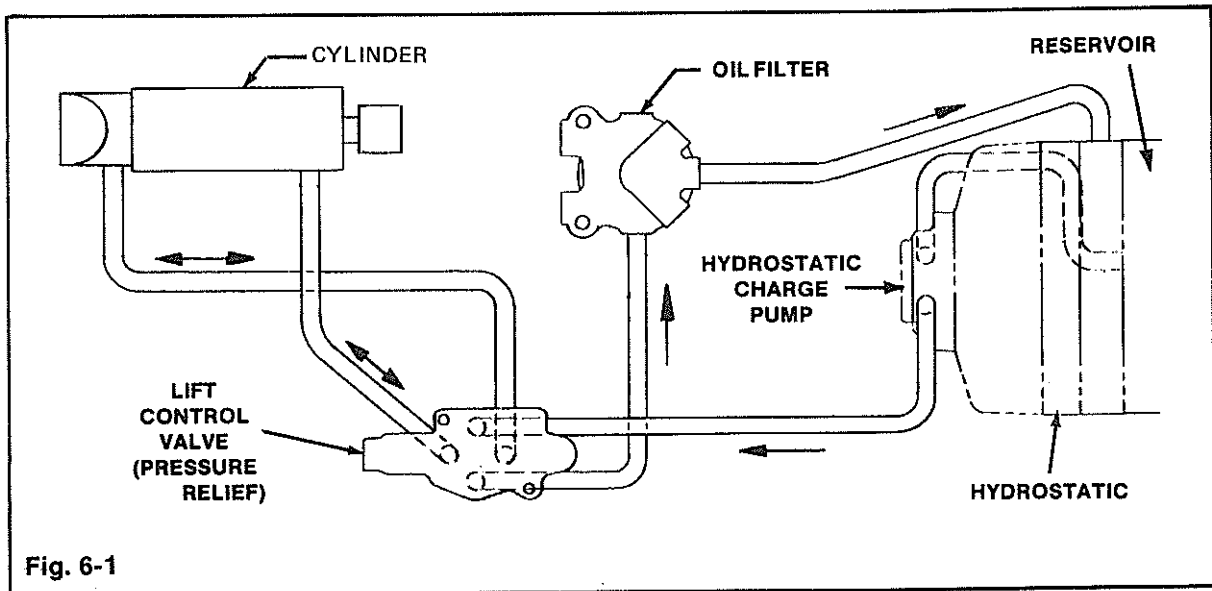

TESTING HYDRAULIC SYSTEM

CAUTION! CARE SHOULD BE TAKEN TO THOROUGHLY INSPECT ALL HYDRAULIC COMPONENTS FOR HIGH PRESSURE LEAKS BEFORE TESTING OR REPAIRING. NEVER 'FEEL' FOR LEAKS, AS OIL LEAKING AT HIGH PRESSURE HAS SUFFICIENT FORCE TO PENETRATE THE SKIN AND CAUSE SERIOUS INJURY. USE EXTREME CARE WHEN WORKING WITH A SYSTEM AT OPERATING TEMPERATURES AS SEVERE BURNS CAN BE CAUSED BY CONTACT WITH HOT FLUIDS.

The following procedures can be used as a basic troubleshooting

method in their entirety, or can be used selectively based on reference from the troubleshooting chart. Prior to proceeding with any test, the fluid level should be checked and adjusted to correct levels. Fluid samples should also be checked for contamination, such as metallic particles. A strong 'burnt' odor would indicate over-heating--the result of over-loading, excessive tolerances, reduced flow of cooling air, or lack of cooling fin maintenance. A milky appearing fluid indicates moisture in the system. Any of these fluid conditions can only be corrected by replacement

of the fluid and a flushing of the system with clean fluid prior to resumption of further testing or operation. The presence of foam in the fluid or reservoir is a sign of air in the hydraulic system, which is the result of a leak in the suction section of the pump and connections, or a high pressure internal leak.

1. Check fluid level.
2. Check for metallic contamination in fluid.
3. Smell for burnt odor or signs of overheating.
4. The hydrostatic pressure can be checked using a pressure gauge which reads at least 1000 P.S.I. hydrostatic Pressure Gauge Kit 1737386 is available at the factory. To check the hydrostatic pressure, install a tee between hydro and tube to the hydraulic lift valve at point (A) Figure 6-2. Connect pressure gauge to tee. Start the engine and run for 5-10 minutes. At full RPM the pressure reading should be 140 P.S.I. \pm 20 (964 kPa). If pressure is below 120 P.S.I., hydrostatic charge pump may have excessive wear. Repair per Eaton II manual.
5. To check the lift pressure move the hydraulic control valve lever to the lift position until the hydraulic cylinder reaches the end of its travel. The pressure reading should be no less than 450 P.S.I. (3100 kPa).
6. If the pressure reading is 450 to 550 P.S.I. (3100 - 3790 kPa) and the hydraulic cylinder does not operate properly, check the following:
 - a. Load too heavy. Check for correct attachment lift hook up.
 - b. Restriction in line from valve to hydraulic cylinder.
 - c. Malfunctioning cylinder or valve. Check for internal leaks caused by wear, worn "O" rings, etc.
7. If the pressure reading is below 450 to 500 P.S.I. (3100 - 3790 kPa) and the hydraulic cylinder does not operate, check the following:
 - a. System low on oil.
 - b. Plugged oil filter or pickup tube line.
 - c. Hydraulic oil line leaking.
 - d. Hydraulic valve or cylinder leaking internally.
 - e. Air or water in the system.

6

HYDRAULIC POWER LIFT

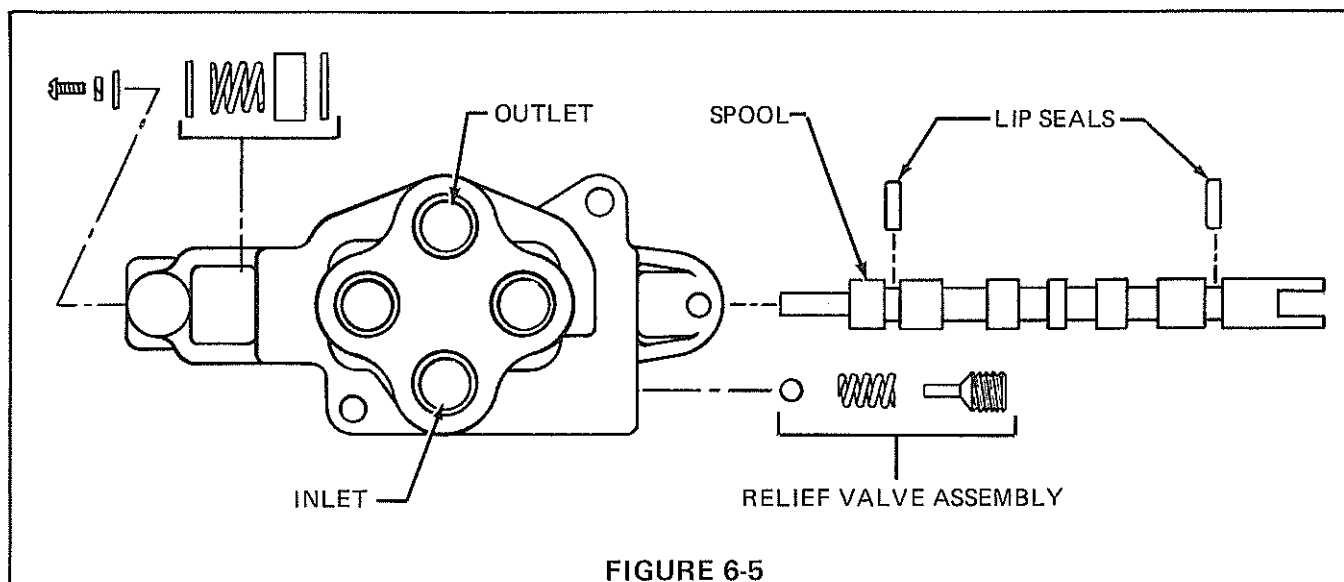

FIGURE 6-5

REPAIRING THE HYDRAULIC CONTROL VALVE

The hydraulic control valve regulates and changes the direction of oil flow to the hydraulic cylinder when the control lever is actuated. "Lip Seals" are used on the spool to provide a seal in the bore.

Repair lip seals are available for the control valve.

DISASSEMBLY

The spool is matched to the bore in the valve body. If the spool or

valve body, is damaged the complete valve assembly must be replaced.

To remove the spool from the valve remove the capscrew in the end of the spool, and flat washer. Remove the spool by pulling it out of the lever end of the valve body.

Small burrs and scratches can be removed from the spool with fine emery cloth. Clean all parts before assembly.

ASSEMBLY

1. Install new lip seal rings onto the spool with the opening towards the inside of spool.
2. Lubricate seals and insert spool with seals into valve body. Be careful not to damage seals. Install the spool into the valve body from the lever end. This end has a chamfer in the bore which is a lead for the packings.
3. Secure spool with round head screw, lock washer and flat washer.

HYDRAULIC POWER LIFT (CONT'D)

REPAIRING THE HYDRAULIC CYLINDER

To remove the piston rod assembly (A) from the cylinder, the internal snap ring (B) and the hose fitting, which goes through hole (C) in the cylinder tube, must be removed.

PISTON ROD REMOVAL

1. Remove 90°elbow from cylinder tube.
- 2 Pull the piston rod out until it is fully extended.
3. Pinch snap ring together and pull on piston rod until the assembly slides out of the cylinder housing.

When the piston rod assembly is removed from the cylinder tube hex nut (D) can be loosened and the piston, cylinder head, and related "O" rings installed.

IMPORANT: Grease "O" rings to prevent damage during assembly.

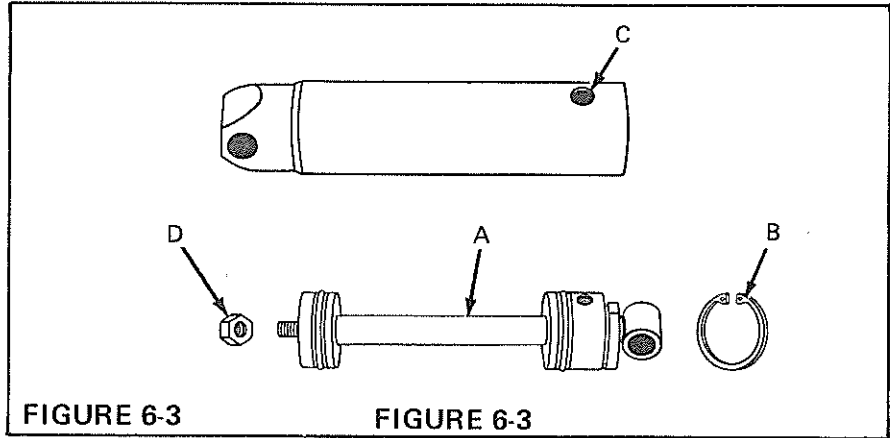

FIGURE 6-3

FIGURE 6-3

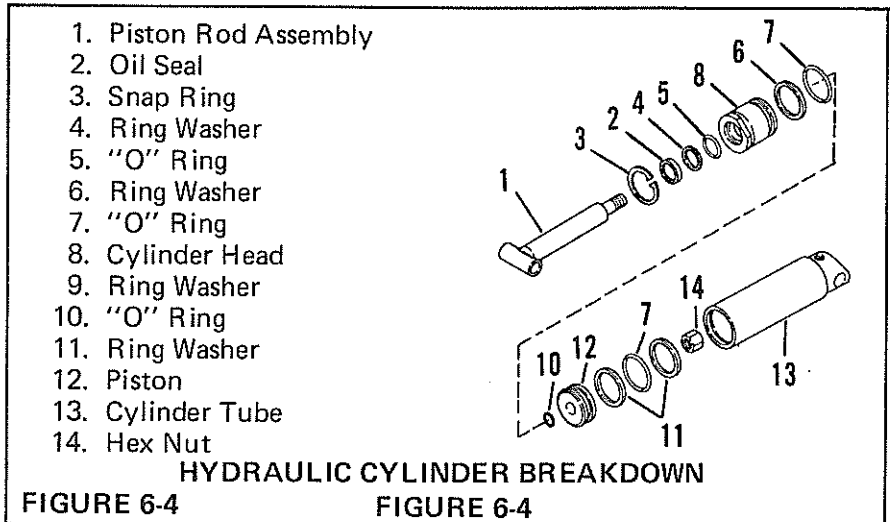

FIGURE 6-4

FIGURE 6-4

TRANSMISSION FILTERS

After the first 25 hours change the oil filter. Thereafter, change the filter at every oil change.

MODEL 1458 S/N 0100101 THRU 0199999 ONLY

The in-line filter is clamped to the top of the battery and fuel tank support, just behind the instrument panel.

Battery must be removed to reach filter.

When replacing filter keep "IN" inlet (stamped on filter) to the left side of the tractor.

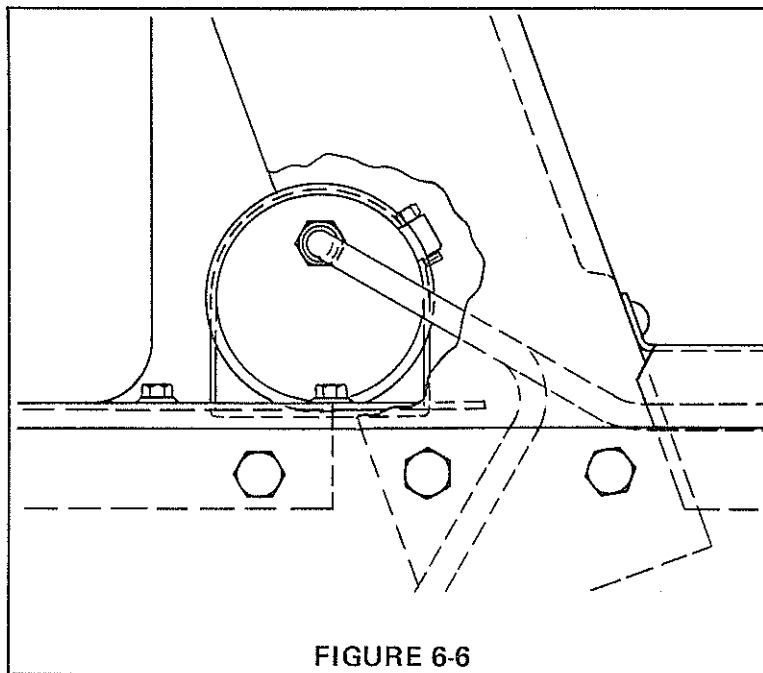

FIGURE 6-6

ALL MODELS EXCEPT 1458-01

The spin on the type filter is located under battery and fuel tank support.

When replacing filter apply a small amount of oil to the filter gasket. Hand tighten the filter.

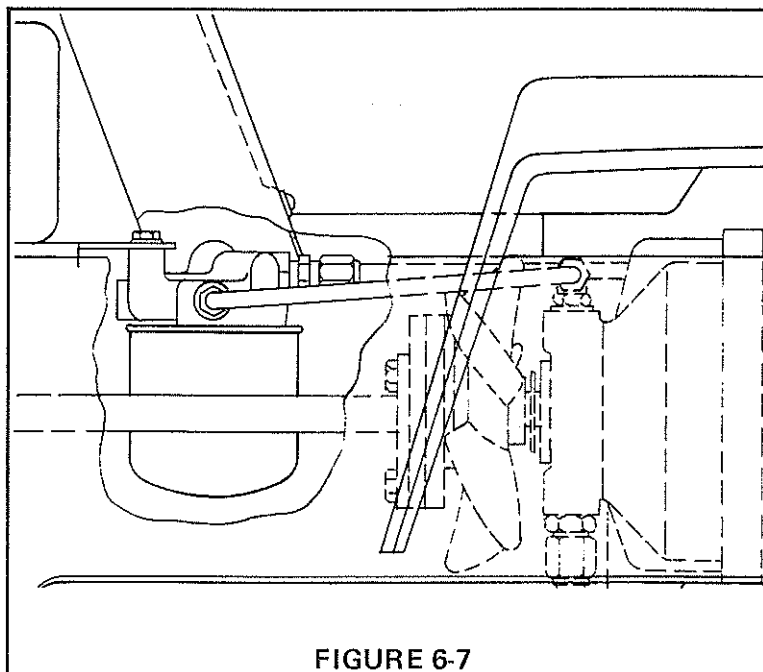

FIGURE 6-7

TROUBLE SHOOTING GUIDE

PROBLEM	PROBABLE CAUSE	REMEDY
Hard starting or loss of power.	<ol style="list-style-type: none"> 1. Engine overchoked. 2. Carburetor dirty or improperly adjusted. 3. Faulty spark plug or improper gap. 4. Clogged fuel line or filter. 5. Loose or grounded high tension wire. 6. Worn or burnt breaker points (Briggs & Stratton only). 7. Faulty condenser (Briggs & Stratton only). 8. Faulty fuel pump. 9. Loose or grounded breaker point wire leads (Briggs & Stratton only). 	<ol style="list-style-type: none"> 1. Close fuel petcock and engage starter until engine fires. Reopen fuel petcock. 2. Readjust or clean carburetor. 3. Adjust gap or replace plug. 4. Check fuel line or filter. 5. Check and repair wire lead. 6. Replace breaker points. 7. Replace condenser. 8. Replace pump. 9. Check and replace.
Overheating.	<ol style="list-style-type: none"> 1. Insufficient available cool air. 2. Dirty air intake screen, shroud or cooling fins. 3. Improper fuel. 4. Fuel mixture too lean. 	<ol style="list-style-type: none"> 1. Make sure area in front of flywheel is open or clean. 2. Clean intake screen, shroud and cooling fins. 3. Clean and refill tank with proper fuel. 4. Adjust carburetor.
Backfiring.	<ol style="list-style-type: none"> 1. Fuel mixture too lean. 2. Hot spot in muffler. 3. Valve "sticking". 	<ol style="list-style-type: none"> 1. Adjust carburetor. 2. Replace muffler. 3. Check compression. Free up valve.
Skip at high speed.	<ol style="list-style-type: none"> 1. Spark plug gap too wide. 2. Improper carburetor setting or lack of fuel. 	<ol style="list-style-type: none"> 1. Adjust spark plug gap. 2. Refill tank and adjust carburetor.

TROUBLE SHOOTING GUIDE (Continued)

PROBLEM	PROBABLE CAUSE	REMEDY
Operating erratically.	<ol style="list-style-type: none">1. Clogged fuel line.2. Water in fuel.3. Improper carburetor adjustment.4. Vent in gas cap plugged.5. Faulty fuel pump.6. Faulty choke control.7. Loose ignition connections.8. Air leaks in manifold or carburetor connections.	<ol style="list-style-type: none">1. Clean fuel line.2. Clean fuel system.3. Adjust carburetor.4. Clean gas cap vent.5. Replace fuel pump.6. Replace choke control.7. Clean and tighten ignition connections.8. Tighten manifold and carburetor.
Engine will not idle.	<ol style="list-style-type: none">1. Improper carburetor idling adjustment.2. Carburetor clogged.3. Spark plug gap set too close.4. Leaking carburetor or manifold gaskets.	<ol style="list-style-type: none">1. Adjust idle speed.2. Clean carburetor.3. Adjust spark plug gap.4. Replace gaskets.

MODEL 1058, 1060 AND 1160
ENGINE REMOVAL AND REINSTALLATION

FIGURE 7-1

REMOVAL

Remove all attachments and PTO kit.

1. Remove hood and side panels.
2. Disconnect negative battery cable.
3. Disconnect starter (red), magneto (blue), 12 volt lead (red), and electric clutch (purple) wires and pull through heat shield.
4. Disconnect engine ground wire (black) from battery support mounting hole on side of frame and pull through heat shield.
5. Close fuel tank petcock, disconnect fuel line at filter and pull through heat shield.

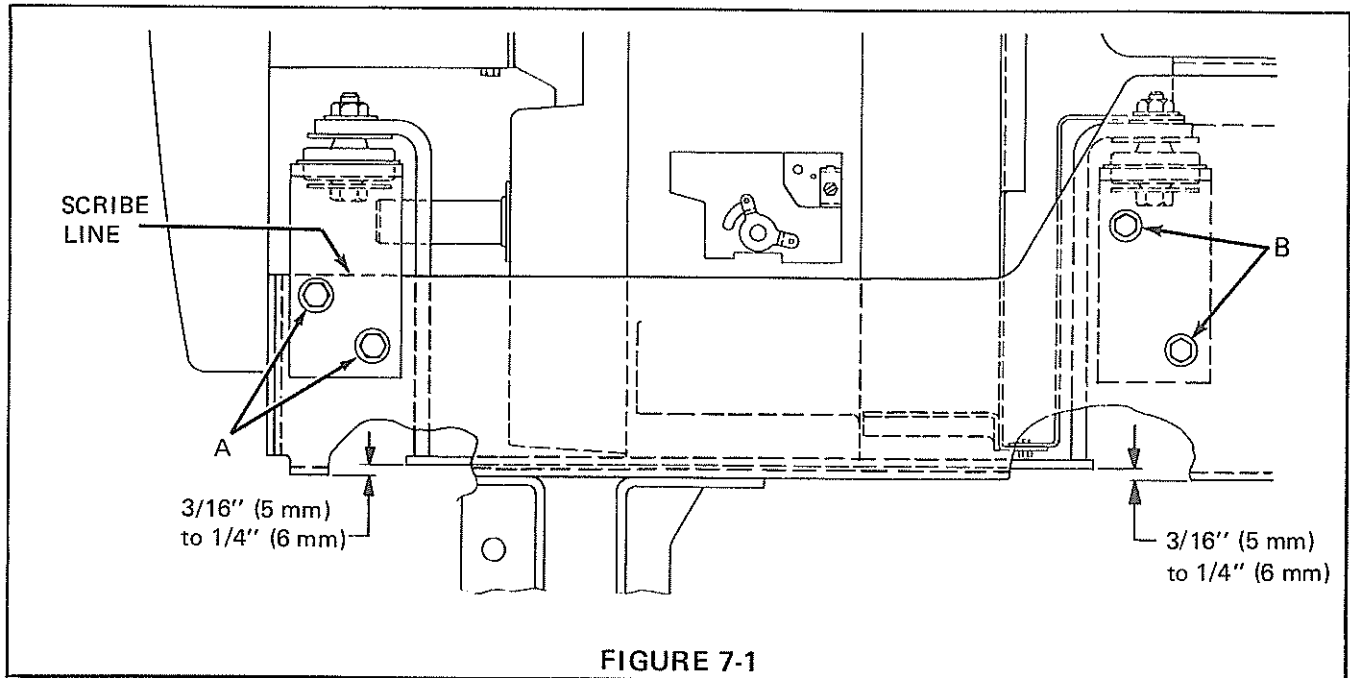
6. Disconnect choke and throttle cables at engine and pull through heat shield.

7. Remove the three rubber mount driveshaft bolts at engine and disconnect the driveshaft.

8. Scribe line on the front engine supports along frame for reinstallation alignment. Loosen two bolts (A) on each side of the engine supports.

9. Remove two rear engine mount bolts (B).

10. When ready to pull engine, remove four bolts from front engine supports.

11. Engine serial number is located behind heat shield on rear of engine.

REINSTALLATION

1. Set engine on rubber mounts in rear, lining up scribe line on front engine supports with frame and insert front four bolts (A). Insert proper engine mount spacers for engine height until a gap of 3/16 (5 mm) to 1/4" (6 mm) is reached between the bottom edge of the engine support and bottom edge of the side frame. This dimension should be held at the front and rear of the engine support. See Figure 7-1. Secure engine supports to frame, holding dimension given above.

7

MODEL 1058, 1060 AND 1160 ENGINE REMOVAL AND REINSTALLATION (CONT)

2. Bring starter, magneto, rectifier, electric clutch and ground wires through heat shield and connect to proper terminals.

3. Pull fuel line through heat shield, connect to fuel filter and open petcock.

4. Pull choke and throttle cables through heat shield and connect (adjustment may be needed) to proper locations.

5. Connect drive shaft and tighten the three bolts on the drive shaft coupling. On hydrostatic models make sure the hub on the hydrostat is 5/16" (8 mm) away from the front face of the

hydrostat. On gear drive models make sure the hub on the right angle gear box is slid all the way to the end of the spline.

With the hubs of the drive shaft in their proper position the two couplings should be flat, not pushed in. If not, reposition the engine.

6. Attach hood and side panels.

7. Connect negative battery cable.

RUBBER MOUNT REPLACEMENT

When replacing the rubber engine mounts, make sure they are correctly placed. To check, push

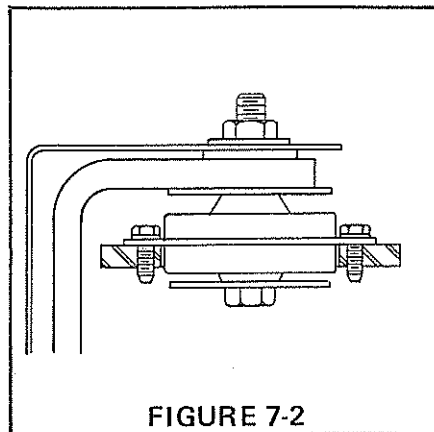

FIGURE 7-2

down on the center of the rubber mount. The softer mount should always go at the rear. See Figure 7-2 for correct assembly.

TECUMSEH MODELS ENGINE REMOVAL AND REINSTALLATION

REMOVAL (Figure 7-3)

1. Disconnect negative battery cable.

2. Remove hood and side panels (disconnect light harness at connector).

3. Disconnect throttle and choke cables at engine and pull through heat shield.

4. Close fuel petcock and disconnect fuel line at fuel filter.

5. Disconnect electric clutch wire (purple).

6. Disconnect wire harness at connector (red & blue).

7. Disconnect starter wire (red) and ground wire (black) and pull all wires through heat shield.

8. Disconnect and remove three driveshaft bolts at flywheel.

9. Scribe line on front engine supports along frame, for reinstallation alignment. Loosen two bolts (B) on each side of the engine supports.

10. Remove two rear engine mount bolts.

11. When ready to pull engine, remove four bolts from front engine supports.

REINSTALLATION

1. Set engine on rubber mounts in rear, lining up scribe line on front engine supports with frame, and insert front two bolts (B) on each side. Insert proper engine mount spacers for engine height until a gap of 7/16" (11 mm) to 1/2" (13 mm) is reached between the bottom surface of the engine support and inside surface of the frame. This dimension should be held at the front and rear of the engine support. Secure supports to frame holding dimension given above.

TECUMSEH MODELS ENGINE REMOVAL AND REINSTALLATION (CONT)

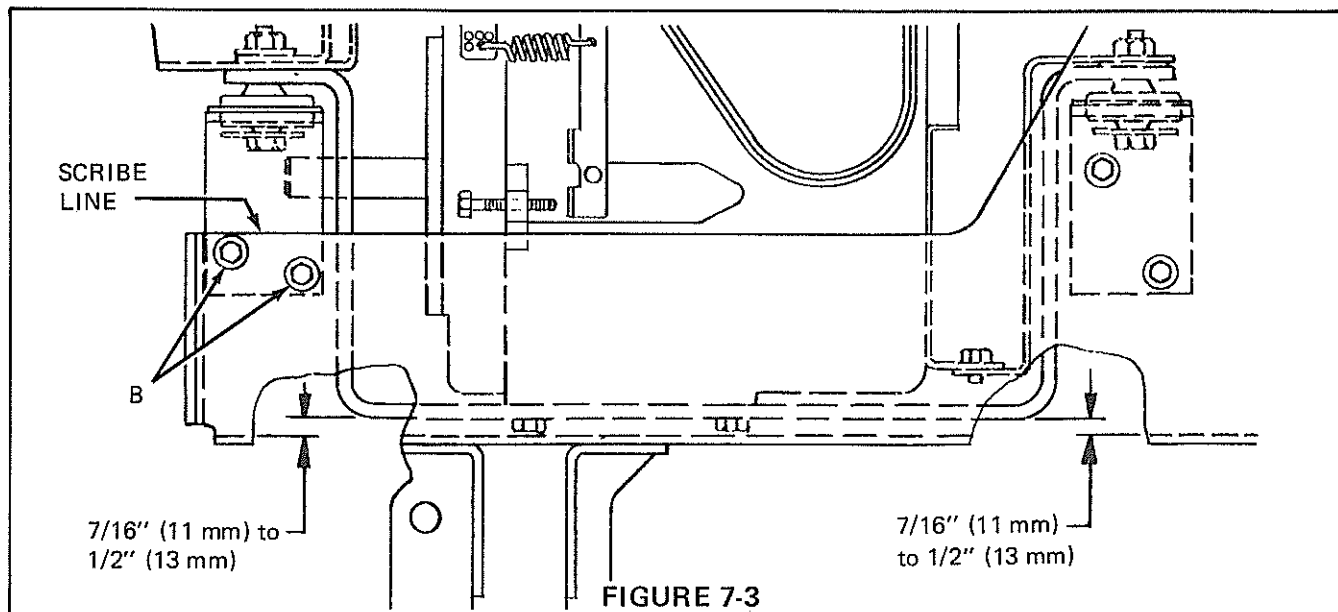

FIGURE 7-3

2. Bring starter (red), ground (black), electric clutch (purple) wires, and engine wire harness (red and green wires) through the heat shield and connect to proper terminals.
3. Connect fuel line to fuel filter and open fuel petcock.
4. Pull choke and throttle cables through heat shield and connect to proper locations (adjust later).
5. Connect drive shaft and tighten the three bolts on the drive shaft coupling. On hydrostatic models, make sure the hub on the hydrostat is $5/16$ " (8 mm) away from the front face of the hydrostat. On gear drive models, make sure the hub on the right angle gear box is slid all the way to the end of the spline.

With the hubs of the drive shaft in their proper position the two couplings should be flat, not pushed in. If not, reposition the engine.

6. Attach hood and side panels.
7. Connect negative battery cable.

RUBBER MOUNT REPLACEMENT

When replacing the rubber engine mounts, make sure that the correct mount is replaced. To check, push down on the center of the rubber mount. The softer mounts should always go to the rear. See Figure 7-4 for correct assembly.

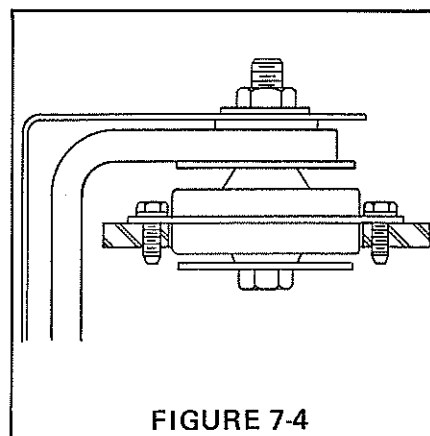

FIGURE 7-4

MODEL 1659, 1662, 1667, 1668, 1668L & 1467 ENGINE REMOVAL AND REINSTALLATION

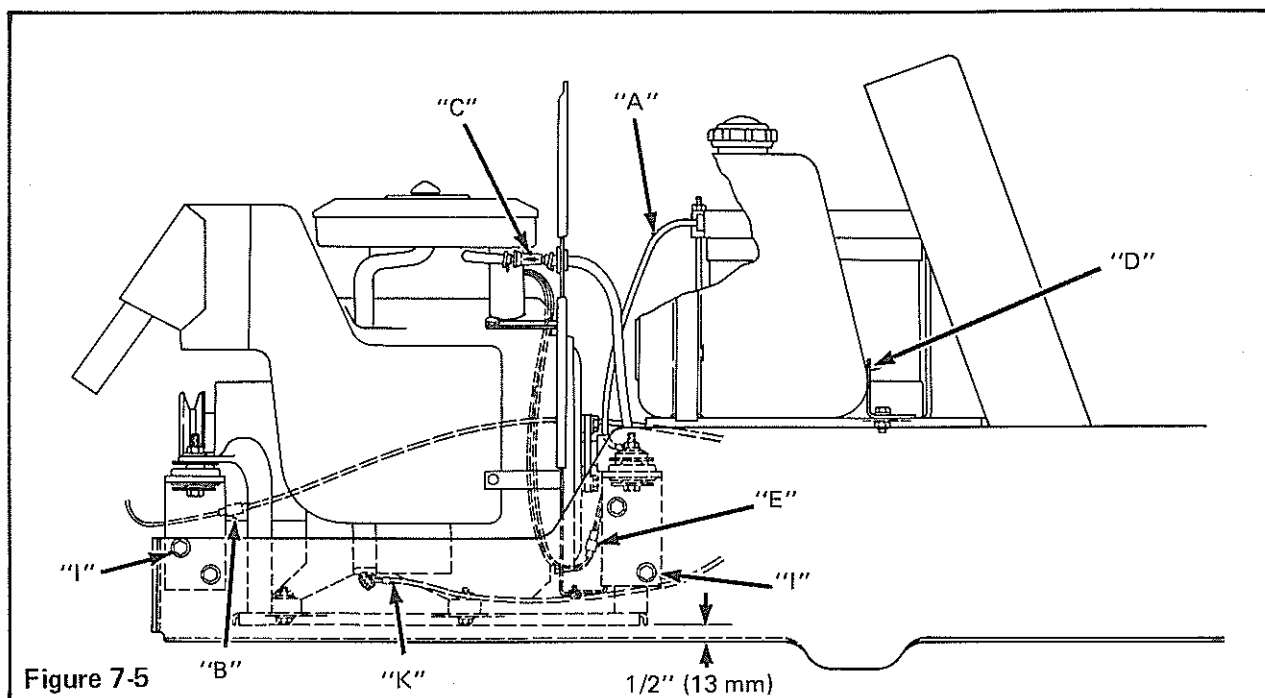

Figure 7-5

REMOVAL

1. Disconnect negative battery cable (A) from battery.
2. Remove hood and side panels (disconnect light harness at connector-B).
3. Disconnect throttle and choke cables at engine and pull through heat shield.
4. Close fuel petcock and disconnect fuel line at fuel filter (C). Remove bracket (D), Figure 7-5 and fuel tank.
5. Disconnect electric clutch wire (purple).
6. Disconnect wire harness (E) Figure 7-4 at connector.
7. Remove R.H. rear engine mount bolt (F), Figure 7-6 & 7-7. Notice placement of star washer and negative battery cable.
8. Remove two bolts (G), Figure 7-6 securing engine hub to flywheel. Notice the flat washer between hub (H) and flywheel.
9. Scribe line on front engine supports and L.H. rear support along frame. Loosen two bolts (I) on each of the engine supports.
10. When ready to pull engine, remove bolts (J), Figures 7-7 & 7-8 from the engine supports.
11. Lift engine straight up till starter wire (K), Figure 7-5 can be removed.
12. Slide hub (H) of drive shaft off when removing engine.

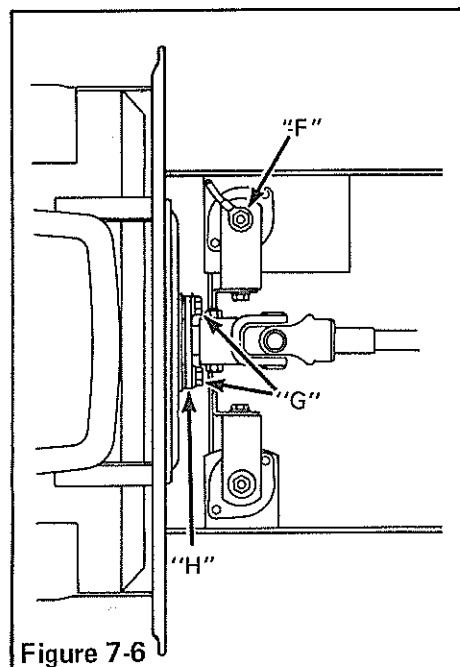

Figure 7-6

REINSTALLATION

1. Set engine on R.H. rubber mount in rear. Lift engine and install (red) starter wire (K). Insert hub (H), Figure 7-6, of drive shaft into pilot hole in flywheel. Line up scribed line on front and rear engine supports with frame, insert two bolts (I) through each support. Secure mounts in place, holding with a gap of 1/2" (13 mm) between the bottom surface of the engine support and inside surface of the frame.

NOTE

Rear R.H. mount has a pyramid washer (L) Figure 7-7 between mount and nut.

This dimension should be held at the front and rear of the engine support. See Figure 7-5.

2. Secure (black) negative battery wire (A), Figure 7-7 to R.H. rear engine mount. Place star washer on first and then the negative wire. Secure with nut.

3. Bring engine wire harness through the heat shield and connect to head light harness and electric clutch.

4. Connect engine plug (E), Figure 7-5 to harness.
5. Position drive shaft hub (H) over mounting holes of flywheel and secure with existing screws. Make sure that there is a flat washer between the hub and flywheel. Tighten both bolts the same so hub does not cock.
6. Install fuel tank and bracket (D).
7. Connect fuel line to fuel filter and open fuel petcock.
8. Pull choke and throttle cable through heat shield and connect to proper locations.

NORMAL MOUNT

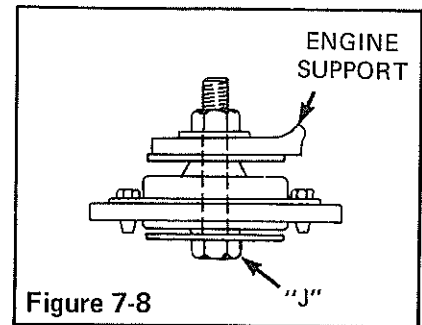
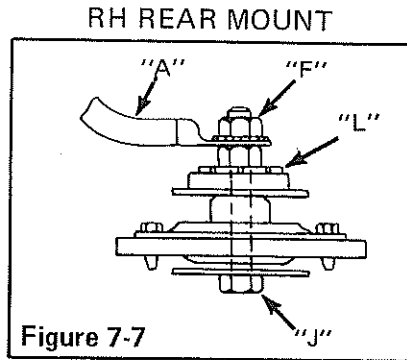

When the hub is in place on the gear drive models the two couplings should be flat not pushed in. If not, reposition the engine.

9. Attach hood and side panels.
10. Connect negative battery cable.

VANGUARD ENGINE, REMOVAL AND REINSTALLATION

REMOVAL (Figures 7-5, 7-6 & 7-7)

1. Disconnect the black ground (-) cable and red positive (+) cable at battery (A).
2. Disconnect headlight harness at connector (C).
3. Remove hood by removing hinge rod.
4. Disconnect purple electric clutch wire (D).
5. Disconnect red wire (E) to regulator and red/black wire (F) to engine.
6. Disconnect blue ignition wire (G) from tab terminal at engine.

NOTE - Be careful to prevent the tab from breaking.

7. Remove black ground wire (H) from engine blower housing. Cut wire ties where necessary.
8. Disconnect red positive (+) cable (I) at starter and black ground (-) cable (J) at rear R.H. engine. Pull all wires thru heat shield.
9. Disconnect throttle cable (K) and choke cable (L) at the engine and pull wires thru heat shield.

NOTE -Choke wire must be connected to the same hole when reinstalling.

10. Unhook fuel tank strap and raise fuel tank to provide access to shut off valve. Close shut off valve (M) on bottom of tank.

11. Disconnect fuel line at filter (N) and pull fuel tank line thru engine cradle. This will prevent interference when removing engine.

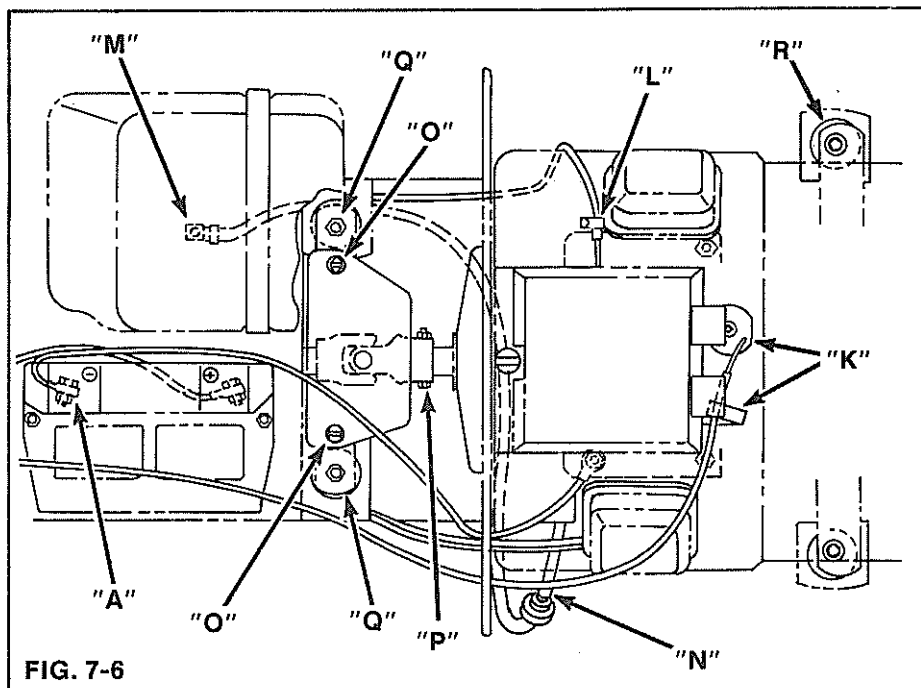
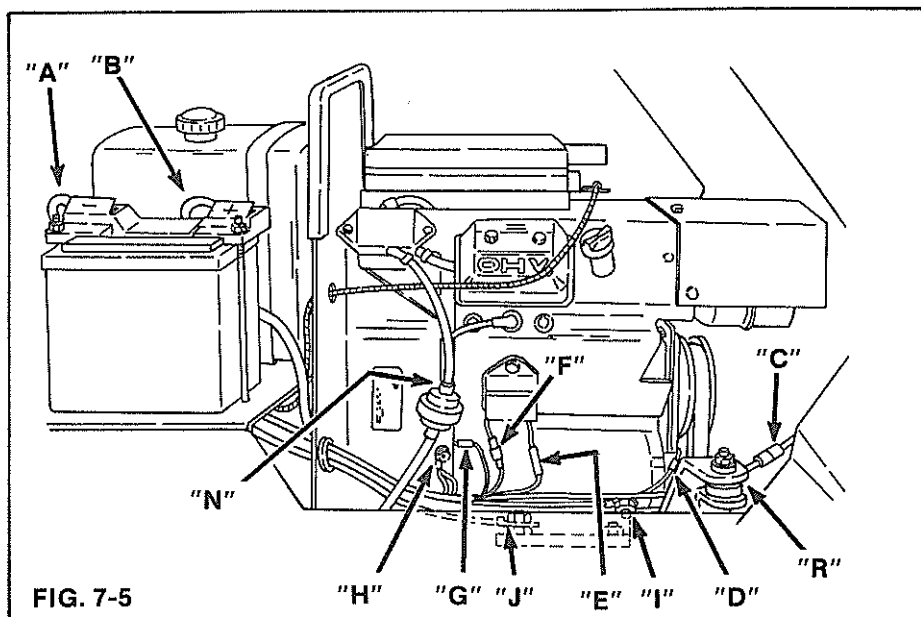

12. Remove two screws securing guard (O) to rear engine mounts. Remove nut and bolt (P) from driveshaft. Slide driveshaft off the engine shaft.

13. Remove nuts and bolts from mounts, (Q), at rear of engine Figure 7-6. Remove same from mounts, (R), at front of engine, 7-5.

14. Lift engine assembly up and forward from tractor frame.
15. Remove engine support (cradle) and miscellaneous parts from engine if necessary. Save all hardware for reinstallation.

REINSTALLATION (Figures 7-5, 7-6 & 7-7)

1. Replace rubber isolator mounts in tractor frame, if broken or otherwise deteriorated.
 2. Set engine on rubber mounts. Install large washers (S) between engine support and rubber mounts.
 3. Install driveshaft to engine.
- NOTE** - If the two piece driveshaft has been pulled apart, look for aligning marks on the two halves when assembling.
4. Install the four 3/8 x 2-1/4 bolts (T) with locknuts Figure 7-7.
 5. Install the guard (O), Figure 7-6, to the engine mounts.
 6. Connect the fuel line at filter (N), Figure 7-5 and 7-6.

NOTE - The fuel line from the tank must be routed thru the engine support away from driveshaft and other moving parts. Open fuel shut off valve (M) on fuel tank Figure 7-5.

7. Connect throttle cable (K) and choke cable (L), Figure 7-6. Route throttle cable thru heat shield first.

NOTE - Be sure choke wire is installed in forward hole on choke lever. Tighten clamps.

8. Install all wires thru heat shield. Connect black ground (-) cable to right hand rear engine mounting bolt (J), Figure 7-5. Connect red positive (+) cable (I) to starter terminals.

9. Install block ground wire (H) to engine blower housing. Carefully connect blue ignition wire (G) to tab at engine.

10. Connect red/black wire (F) to engine lead.

11. Connect red wire (E) to regulator lead.

12. Connect purple wire (D) to electric clutch lead.

13. Install hood to tractor.

14. Connect headlight harness (C) to lead from the lights.

15. Connect red positive (+) cable (B) and black ground (-) cable (A) to battery.

16. Re-check all connections and test run tractor.

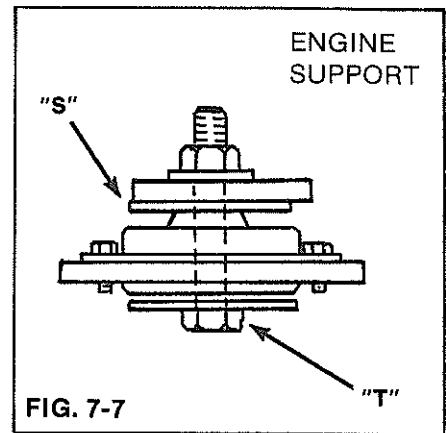

MOWER DECKS

MOWER LEVELING MODELS 18300, 18301, 18335 & 18336

For best cutting results it is important that the mower be leveled correctly.

1. Check tractor tire pressure.
Front - 12 PSI (88 kPa)
Rear - 8 PSI (55 kPa)
2. Place mower on a level, flat surface.
3. Place cutting height adjustment lever (A), Fig. 8-1 in No. 4 position and lower mower with tractor lift.
4. Check side to side level by measuring distance between blade tip and floor Fig. 8-2. If distance varies more than 1/16" (1.56 mm) from left hand side to the right hand, adjustment is necessary.
5. Raise mower with tractor lift and adjust side to side by turning clevis up or down on left hand side of mower. Loosen jam nut (B), remove spring cotter and clevis pin (C).
6. Rotate clevis (D) 1/2 turn to achieve a 1/32" (.78 mm) adjustment. If side of mower is too low, lengthen rod. Shorten rod if too high.
7. Reinstall clevis and spring cotter. Tighten jam nut.
8. Lower mower with tractor lift and check measurement again. Readjust if necessary.
9. Check front to rear leveling by measuring the distance from the blade tip (E) Fig. 8-3 and the floor. If distance varies more than 1/8" front to back, adjustment is necessary. Adjust as follows:
10. Lift mower with tractor lift, remove pins (F) and loosen jam nuts (G) on the tie rods.
11. One turn of clevis (H) Fig. 8-2 and 8-3, will vary the rod length approximately 1/16" (1.56mm). Shorten rod to raise front and lengthen to lower. Adjust both rods same number of turns.

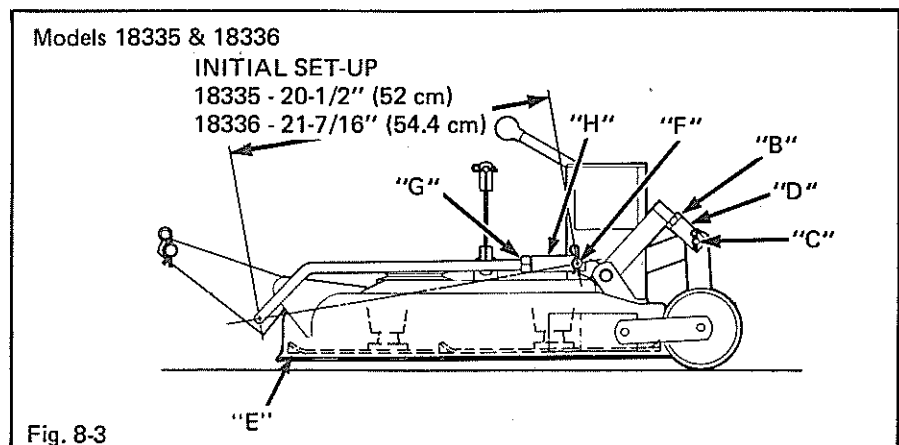
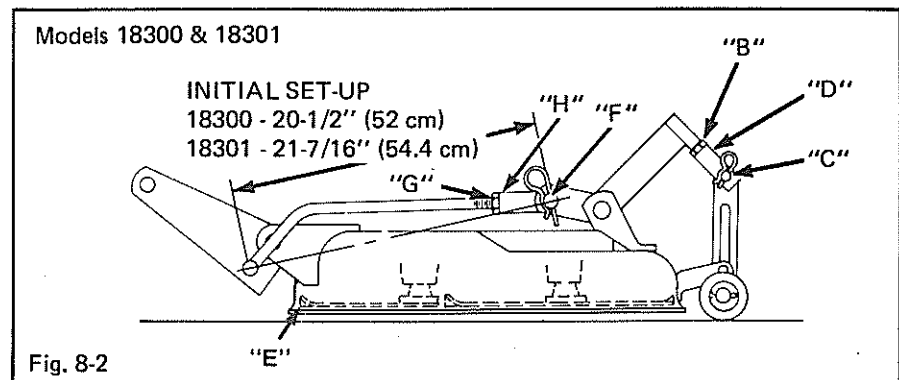
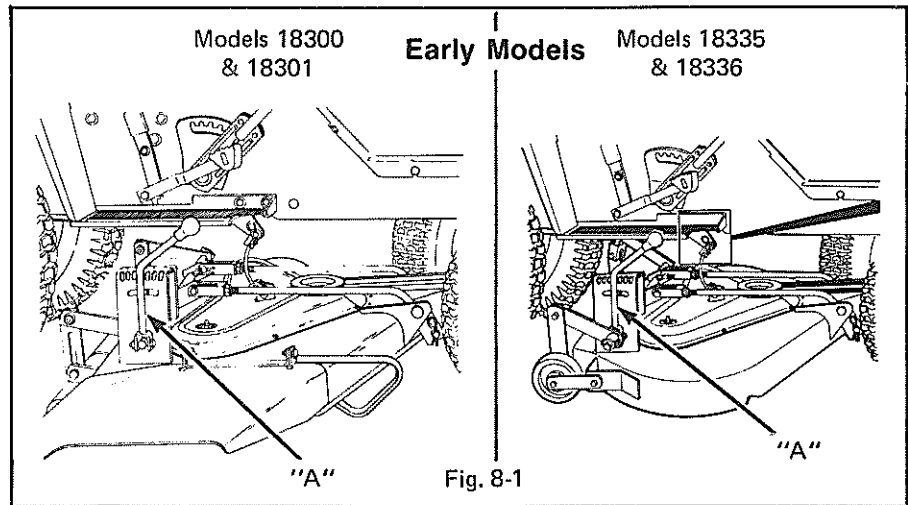

12. Reinstall the pins and tighten jam nuts.
13. After adjustments have been made, activate lift of mower. Let mower drop to the ground a few times. Then recheck measurements. Readjust if necessary.

MOWER DECKS

SPINDLE REMOVAL AND DISASSEMBLY (Figure 8-4 & 8-5)

1. Remove belt covers.
2. Remove belt from spindle.
3. Remove top pulley (A).
4. Remove two bolts securing cutting blade.
5. Remove 4 bolts (B) holding spindle assembly and remove spindle assembly from mower deck.
6. Remove shaft assembly from spindle housing.

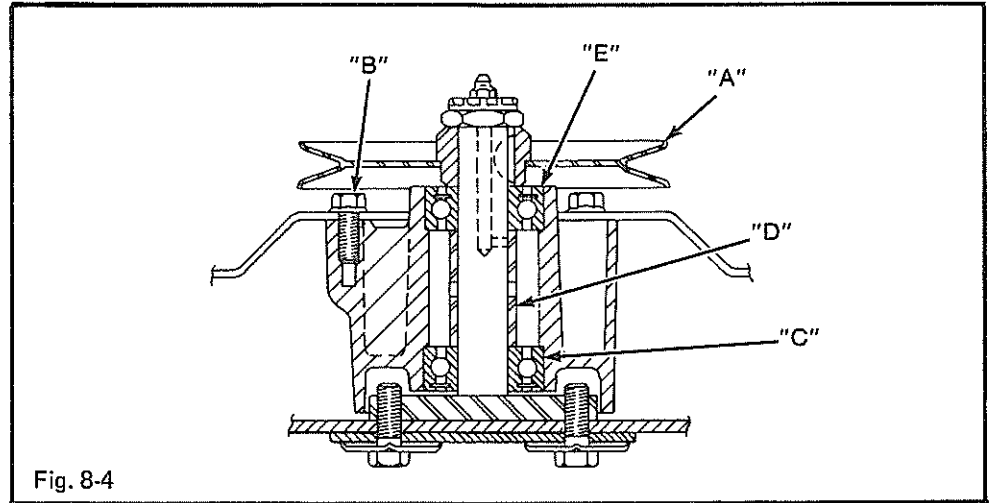

Fig. 8-4

SPINDLE ASSEMBLY (Figure 8-4)

1. Place bearing (C) on shaft assembly.
2. Place spacer (D) on shaft assembly.
3. Place shaft assembly in spindle housing.
4. Place other bearing (E) on shaft assembly.
5. Place spindle housing assembly on mower deck and secure. Torque four (4) bolts (B) to 250 in. lbs. (28 Nm).
6. Assemble spindle sheave (A). Secure nut and torque to 90 ft. lbs. (122 Nm).
7. Assemble blade, spacer and bolts with lockwashers.
8. Torque bolts to 300 in. lbs. (34 Nm).

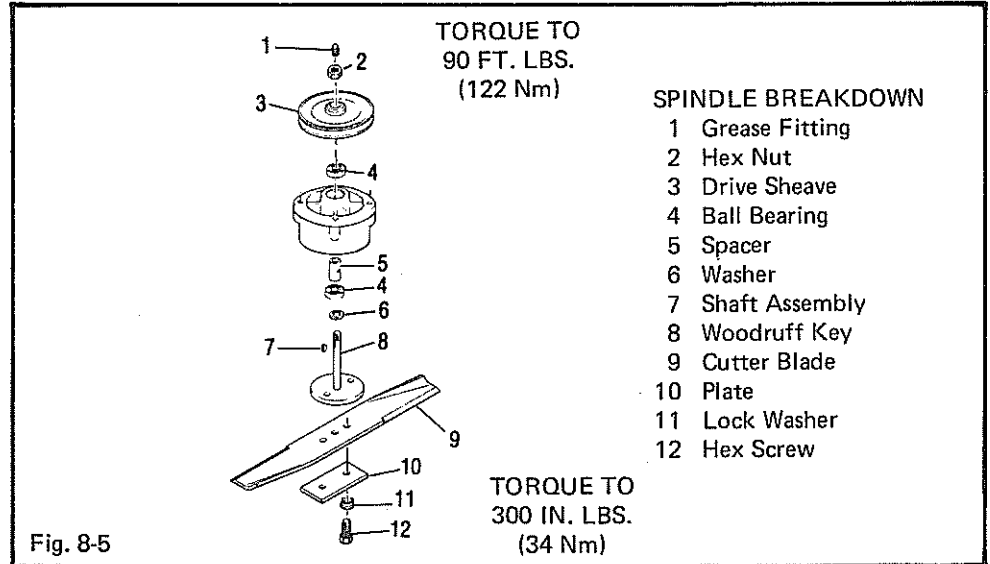
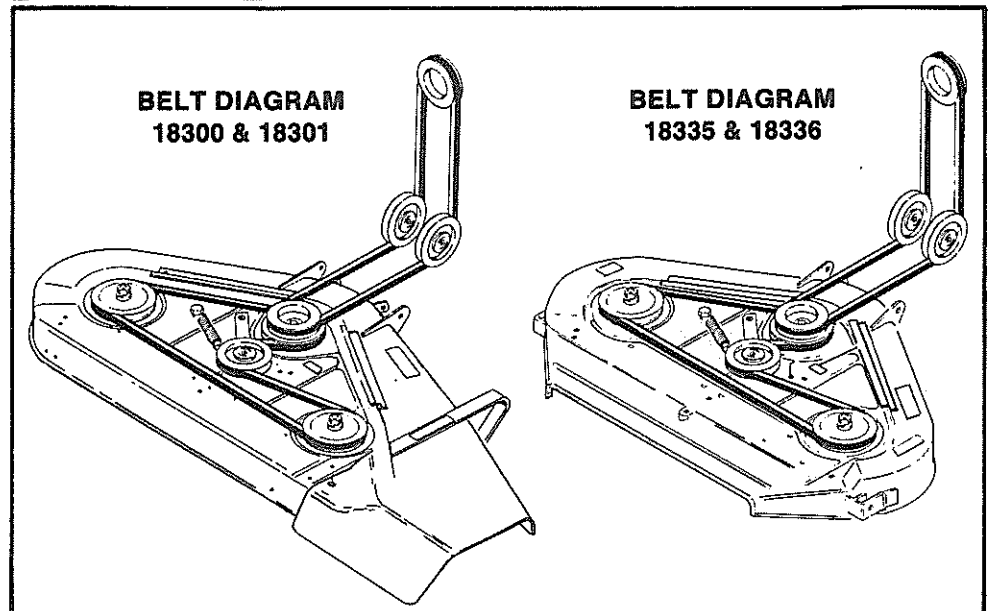

Fig. 8-5

LUBRICATION

There are three grease fittings on the mower; one on top of each blade spindle. Lubricate these grease fittings after every 100 hours of operation with multi-purpose grease and grease gun.

Frequently lubricate the linkage, gauge rollers and other pivot points with a few drops of lubricating oil, especially on mower after washing out.



MOWER DECKS

MOWER LEVELING MODEL 18338

For best cutting results it is important that the mower be leveled correctly.

1. Check tractor tire pressure.
Front - 12 PSI (88 kPa)
Rear - 8 PSI (55 kPa)
2. Place mower on a level, flat surface.
3. Place cutting height adjustment lever (A), Fig. 8-7 in No. 4 position and lower mower with tractor lift.
4. Check side to side level by measuring distance between blade tip and floor Fig. 8-7. If distance varies more than 1/16" (1.56 mm) from left hand side to the right hand, adjustment is necessary.
5. Raise mower with tractor lift and adjust side to side by turning clevis up or down on left hand side of mower. Loosen jam nut (B), remove spring cotter and clevis pin (C).
6. Rotate clevis (D) 1/2 turn to achieve a 1/32" (.78 mm) adjustment. If side of mower is too low, lengthen rod. Shorten rod if too high.
7. Reinstall clevis and spring cotter. Tighten jam nut.
8. Lower mower with tractor lift and check measurement again. Readjust if necessary.
9. Check front to rear leveling by measuring the distance from the blade tip (E) Fig. 8-7 and the floor. If distance varies more than 1/8" front to back, adjustment is necessary. Adjust as follows:

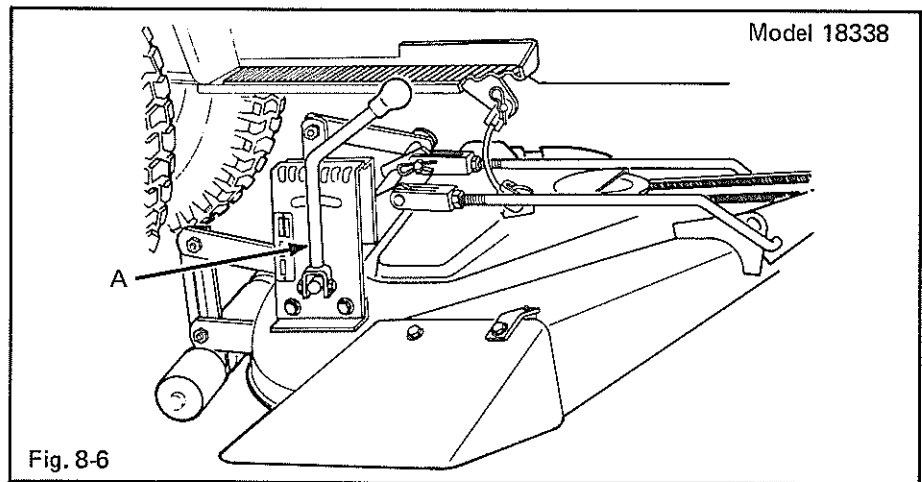

Fig. 8-6

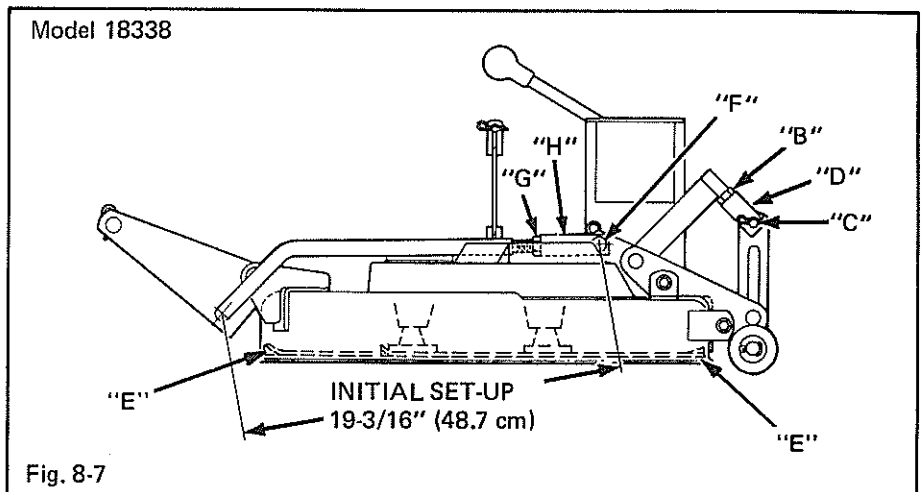

Fig. 8-7

10. Lift mower with tractor lift, remove pins (F) and loosen jam nuts (G) on the tie rods, Fig. 8-7.
11. One turn of clevis (H) Fig. 8-7, will vary the rod length approximately 1/16" (1.56 mm). Shorten rod to raise front of mower and lengthen to lower. Turn both rods same number of turns.
12. Reinstall the pins and tighten jam nuts.
13. After adjustments have been made, activate lift of mower. Let mower drop to the ground a few times. Then recheck measurements. Readjust if necessary.

MOWER DECKS

SPINDLE REMOVAL AND DISASSEMBLY (Figure 8-8)

1. Remove belt covers.
2. Remove belt from spindle.
3. Remove top sheave (A) and woodruff key.
4. Remove two bolts securing cutting blade.
5. Remove 4 bolts (B) holding spindle assembly and remove spindle assembly from mower deck.

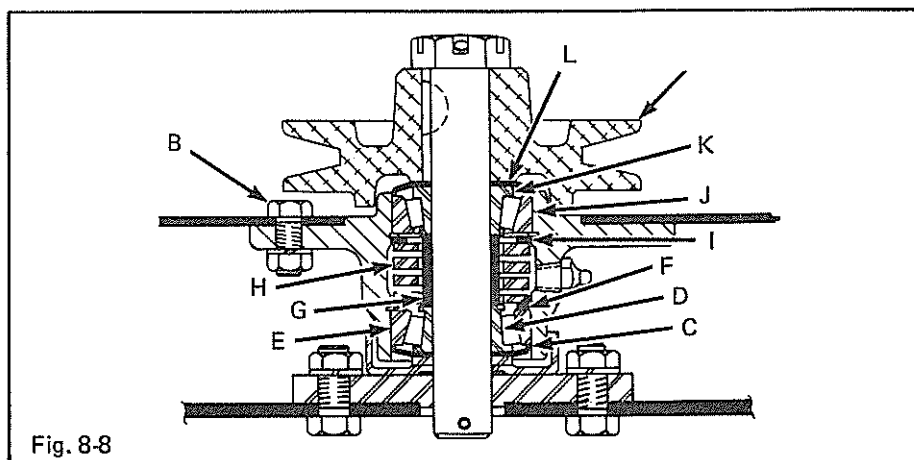

Fig. 8-8

6. Remove shaft assembly from spindle housing.

SPINDLE ASSEMBLY (Figure 8-8 & 8-9)

1. Place Seal (C) on shaft assembly.
2. Assemble Bearing cone (D) and cup (E) on shaft.
3. Slide on outer spacer (F), inner spacer (G) and spring (H).
4. Place outer spacer (I) over shaft assembly.
5. Place Bearing cup (J) and cone (K) into top of spindle housing.
6. Assemble seal (L) into housing.

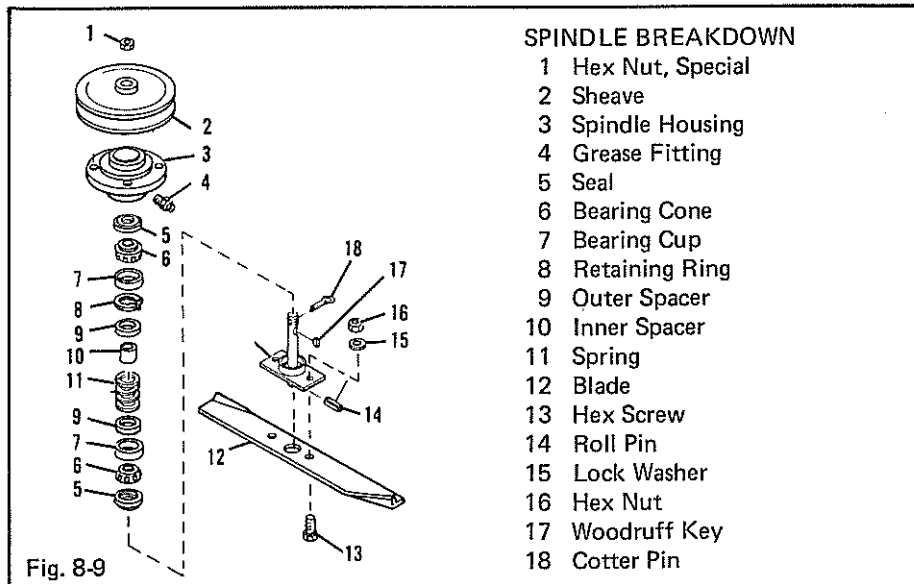

Fig. 8-9

SPINDLE BREAKDOWN

- 1 Hex Nut, Special
- 2 Sheave
- 3 Spindle Housing
- 4 Grease Fitting
- 5 Seal
- 6 Bearing Cone
- 7 Bearing Cup
- 8 Retaining Ring
- 9 Outer Spacer
- 10 Inner Spacer
- 11 Spring
- 12 Blade
- 13 Hex Screw
- 14 Roll Pin
- 15 Lock Washer
- 16 Hex Nut
- 17 Woodruff Key
- 18 Cotter Pin

7. Insert complete shaft assembly through bottom of housing.
8. Secure spindle assembly to mower deck using (4) hex screws, lockwashers and hex nuts. Torque bolts to 250 in. lbs. (28 Nm).
9. Place woodruff key into shaft and slide on sheave (A).
10. Secure in place and torque to 90 ft. lbs. (122 Nm).
11. Insert cotter pin to hold nut in place. Do not back nut off to install pin.

12. Replace blade (M) and secure using existing hex nuts, lockwashers and nuts. Torque to 25 ft. lbs. (34 Nm).

LUBRICATION

There are three grease fittings on the mower; one on bottom of each blade spindle. Lubricate these grease fittings every 25 hours of operation with multi-purpose grease and grease gun.

Frequently lubricate the linkage, gauge rollers and other pivot points with a few drops of lubricating oil, especially on mower after washing out.

BELT DIAGRAM

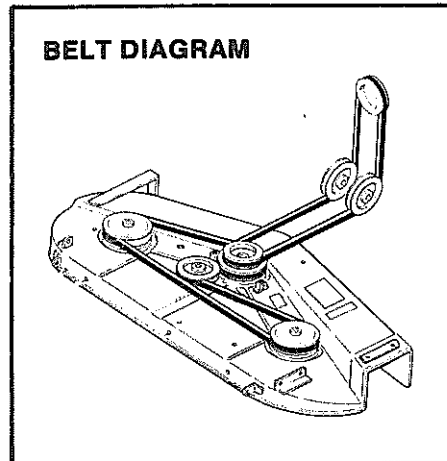

SNOWTHROWER - SINGLE STAGE

CHAIN REMOVAL

1. Remove four screws (A), from guard.
2. Loosen tension block (J) on chain.
3. Locate master link in chain and remove. Chain can now be slipped out.

CHAIN TENSION

The chain is properly adjusted when it has approximately 1/8" (3 mm) of slack. A chain too loose is inclined to jump and too tight a chain will cause excessive wear of chain and sprockets.

To adjust chain tension, first loosen the hex head capscrews securing roller (J). Move the roller down to remove excessive slack.

AUGER REMOVAL

1. Remove chain.
2. Remove the (8) 3/8 x 1/2" screws and lock washers (B) securing the bearings to the housing.
3. Auger should freely slide out.
4. If auger is to be replaced, remove the (2) end bearings. Bearings can be removed with a wheel puller or by heating them.

AUGER REINSTALLATION

1. Coat both ends of auger shaft with loctite Grade D.
2. Place new or old bearings over loctite ends of auger shaft.
3. Place auger in the housing and re-secure bearing (C) using existing hardware.
4. Install chain.

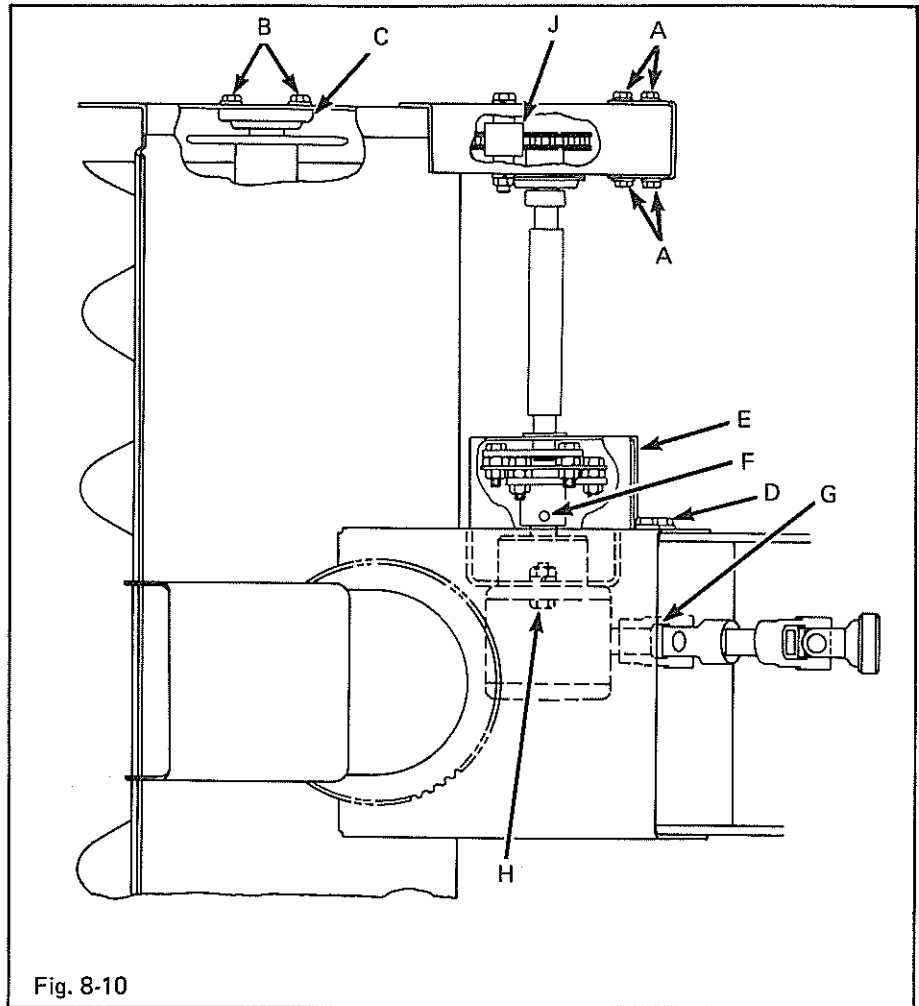

Fig. 8-10

GEAR CASE REMOVAL

1. Remove the (2) hex head screws (D), lock washers and hex nuts securing guard (E) Figure 8-10.
2. Remove guard.
3. Loosen set screws (F).
4. Loosen set screws of universal joint (G) and remove universal.

5. Remove the (2) hex head screws, lock washers and hex nuts (H) securing gear box to housing.

6. The complete gear case can now be removed.

7. When reinstalling the gear case, apply never seeze to output shaft.

8. When reinstalling the universal joint, secure coupling flush with heads of screws.

SNOWTHROWER - SINGLE STAGE (CONT'D)

GEAR CASE DISASSEMBLY

1. Remove cover (A).
2. Locate snap ring (B) and slide ring over shaft (C).
3. Remove cover (D).
4. Remove shaft (C) and bearing (E) from gear case.
5. Remove gear and snap ring.
6. Remove seal (G) and snap ring (H).
7. Output shaft (I) can now be removed through cover end of gear case.

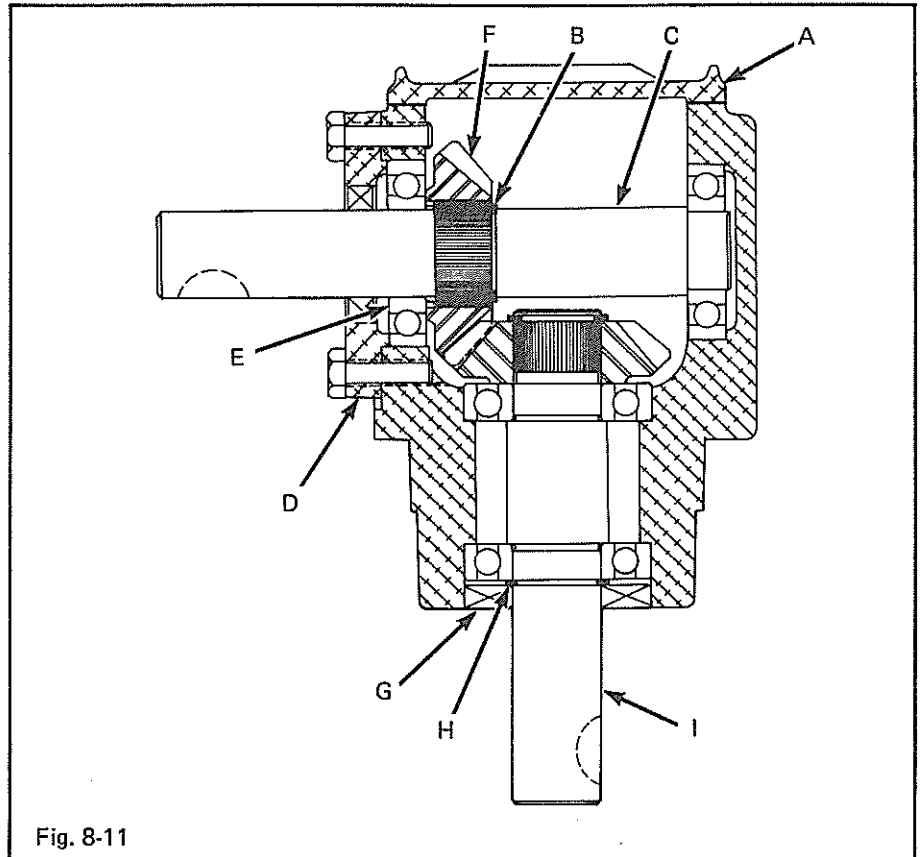

Fig. 8-11

GEAR CASE ASSEMBLY

1. If necessary remove and replace all oil seals and bearings.
2. Reverse the above procedure when assembling.
3. Fill gear case with SAE 90 gear oil to plug level in cover (A).
4. Before assembling the gear case to the housing make sure the input and output shafts turn freely.

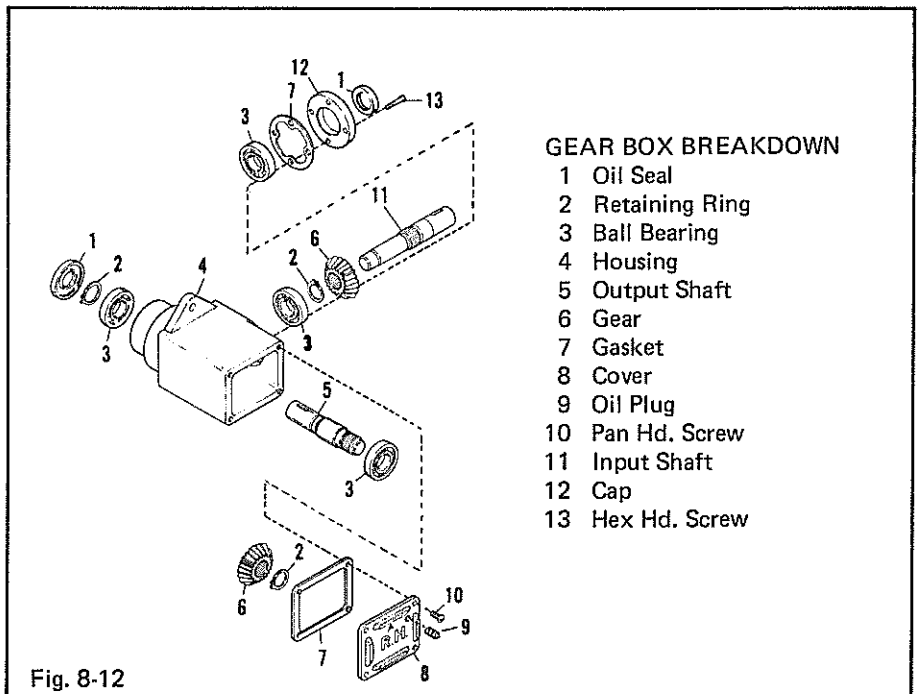

Fig. 8-12

SNOWTHROWER (2 STAGE)

GEAR BOX REPAIR

DISASSEMBLY

1. Loosen sprocket (A) Fig. 8-13 set screws and locking collar set screws behind sprocket. Loosen locking collar by turning.
2. Remove the (2) hex screws and lock washers (B) Fig. 8-14 of auger shaft.
3. Dissassemble gear box from housing support (C).
4. Loosen both set screws and locking collars of housing bearings (D).
5. Remove (6) carriage bolts, lock washers and hex nuts (E) securing housing bearings.
6. Slide gear case as far as possible to the right side and remove the entire auger shaft assembly. Disassemble rear sprocket (A) Fig. 8-13 and key in shaft as complete shaft assembly is being removed.

NOTE:

It may be necessary to pry the shaft out of the side housing.

7. After removing the gear case and auger, disassemble coupling (F) Fig. 8-14 from shaft.
8. Slide off R.H. and L.H. auger blade assemblies.
9. Disassemble gear box and repair as required.

ASSEMBLY

1. Slide on R.H. and L.H. auger assemblies.
2. Secure fan assembly coupling (F) in place.

3. Place both end housing bearing assemblies (D) onto auger shaft.
4. Insert complete assembly into housing. Assemble square key and sprocket (A) Fig. 8-13 onto rear gear box.
5. Secure gear case to housing support (C) Fig. 8-14.
6. Secure flange bearings (D) to end housings.
7. Secure R.H. and L.H. auger assemblies to gear case shaft.
8. Tighten locking bearing collar behind sprocket (A) Fig. 8-13 and tighten set screws.
9. Line up rear sprocket (A) and secure with set screws.
10. Tighten locking collar and set screws on each end housing bearing (D).
11. Torque all screws to approximately 75 in. lbs.

MAINTENANCE

GEARBOX - Check oil level every 10 hours. Fill if necessary with EP 90 extreme pressure oil.

AUGER SHAFT - Grease each shaft at fittings (G) every 24 hours of use.

DRIVE CHAIN - Lubricate chain with chain saw oil every 3 hours.

MOVING PARTS - Oil rotating parts and bearings with multi-purpose oil every 24 hours of use.

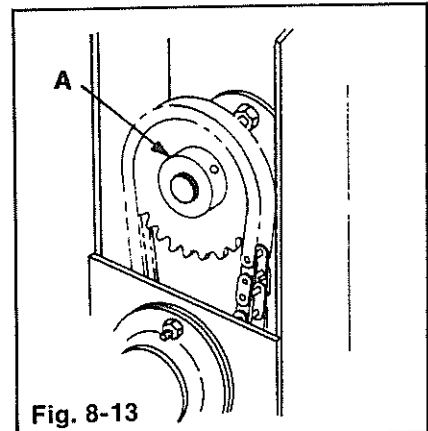

Fig. 8-13

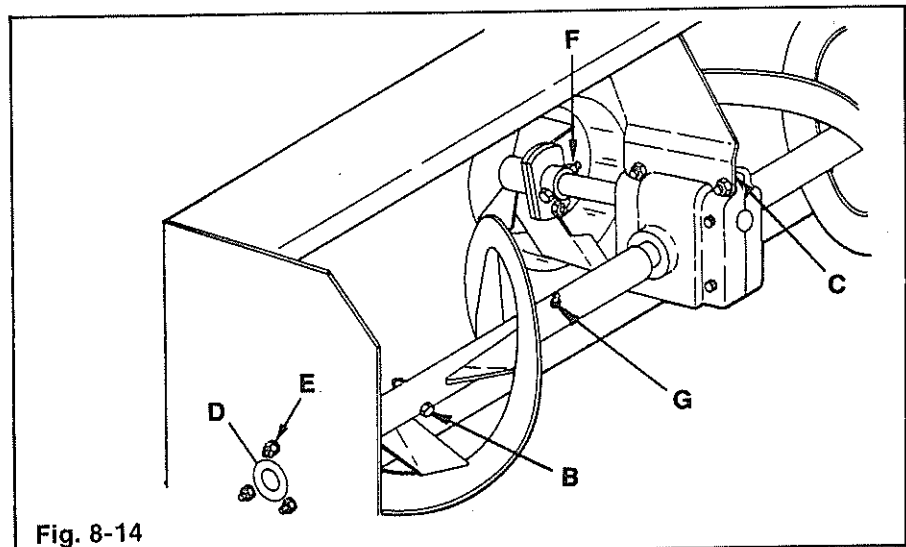

Fig. 8-14

SNOWTHROWER
2 STAGE (CONT'D)

GEAR CASE BREAKDOWN

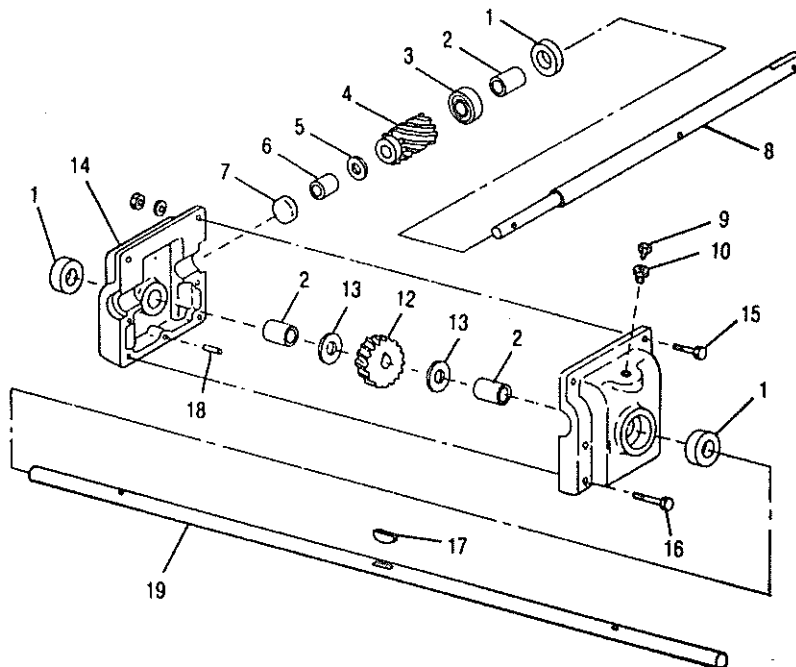

Fig. 8-15

1. Oil Seal CR 9818
2. Bushing (1" int. dia. x 1-1/4" ext. dia. x 1" long)
3. Bearing SKF #51105
4. Worm R.H. Rotation
5. Washer (1-3/8" dia.)
6. Bushing (7/8" int. dia. x 1-1/8" ext. dia. x 1" long)
7. Input Cap
8. Input Shaft
9. Breather (1/8" NPT)
10. Coupling (3/8" NPT Male x 1/8" NPT Female)
11. Cover (R.H.)
12. Bronze Gear
13. Washer (1-1/2" dia.)
14. Cover (L.H.)
15. Bolt (5/16" NC x 1-1/4", Gr. 5)
16. Bolt (5/16" NC x 2-1/2", Gr. 5)
17. Key (Woodruff)
18. Pin (1/4" x 3/4")
19. Output Shaft...

TILLER

LUBRICATION

There is a plug (A) in the rear of the gear case. This is the oil level and fill hole. Check the oil level with the unit mounted on the tractor with tines resting on the ground. The oil should be to the level of this plug hole.

NOTE: Fill gear case with 140W gear oil.

GEAR CASE REMOVAL

1. Remove hood (A) Figure 8-17 from tiller.
2. Remove rear roll pin (B).
3. Disconnect the gear box from the front coupling.
4. Remove rear roll pin (B) securing worm shaft (C) to the front coupling.
5. Disconnect the gear box from the front frame by removing (4) hex nuts (D).
6. Disassemble the two tine assemblies from the gear case shafts by removing clevis pins (E).

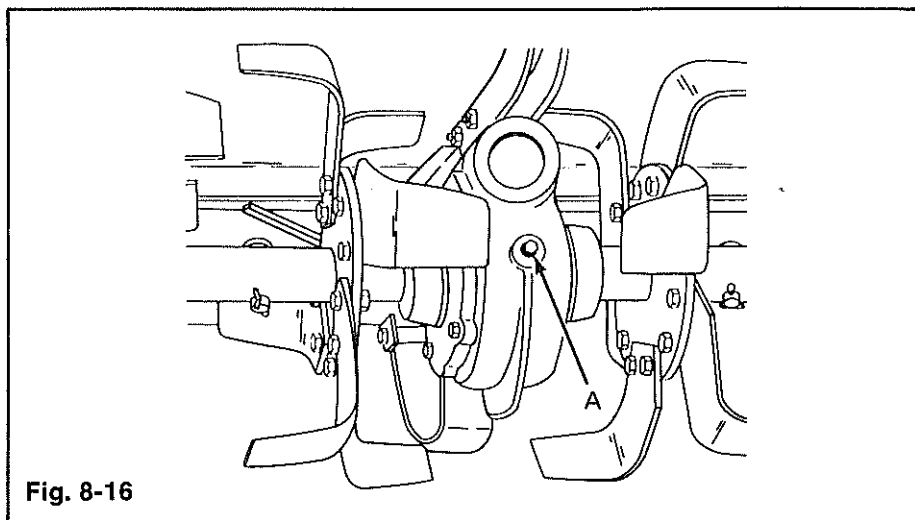

Fig. 8-16

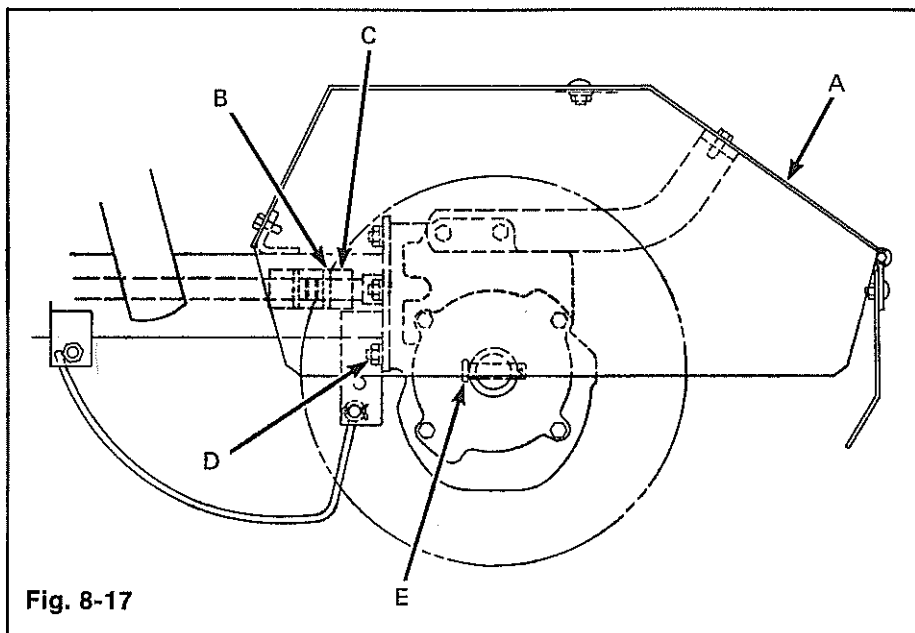

Fig. 8-17

TILLER

GEAR CASE DISASSEMBLY

1. Drain the gear case through oil fill (A) Figure 8-18.
2. Disassemble worm shaft (C) by removing oil seal (F) snap ring and ball bearing (G). Note position of shims on worm shaft.
3. Remove cover (I). Be careful not to damage needle bearing (J).
4. Remove tine shaft worm gear and thrust washers.
5. Replace worn or damaged parts.

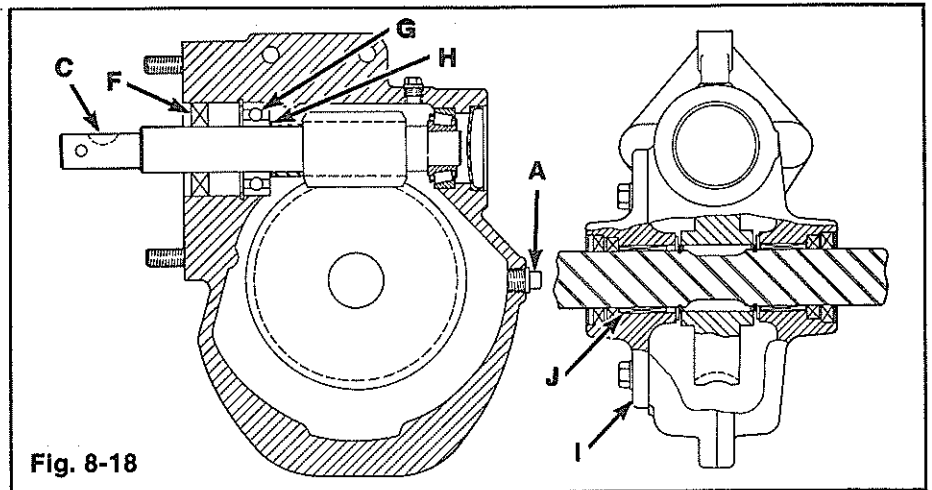

Fig. 8-18

GEAR CASE ASSEMBLY

1. Check all bearings and seals for damage and repair if required.
2. Assemble by reversing the above procedure.
3. Before installing oil seal (F) check the shaft end play. If required, shim at point (H).
4. Fill the case with 16 oz. of gear lubricant.

GEAR CASE REINSTALLATION

1. Reverse the removal procedure.

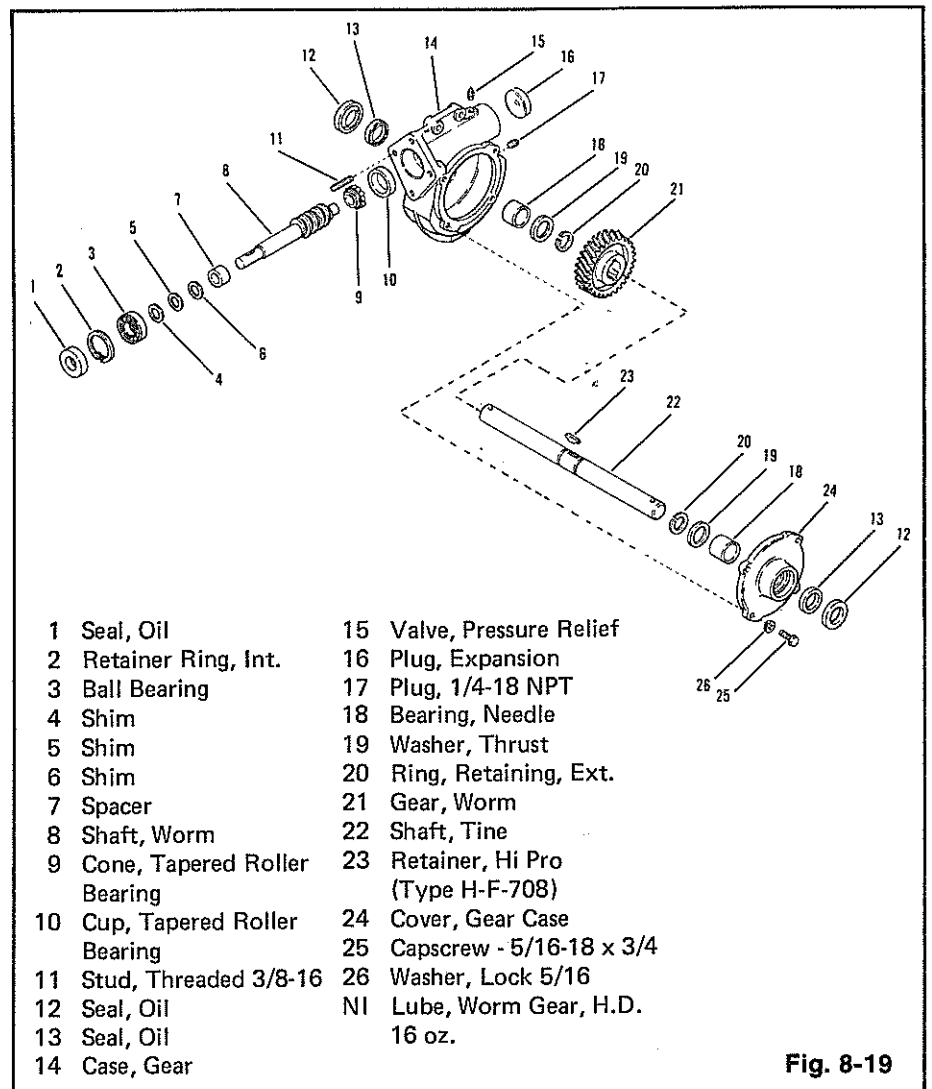

- | | |
|--------------------------------|------------------------------------|
| 1 Seal, Oil | 15 Valve, Pressure Relief |
| 2 Retainer Ring, Int. | 16 Plug, Expansion |
| 3 Ball Bearing | 17 Plug, 1/4-18 NPT |
| 4 Shim | 18 Bearing, Needle |
| 5 Shim | 19 Washer, Thrust |
| 6 Shim | 20 Ring, Retaining, Ext. |
| 7 Spacer | 21 Gear, Worm |
| 8 Shaft, Worm | 22 Shaft, Tine |
| 9 Cone, Tapered Roller Bearing | 23 Retainer, Hi Pro (Type H-F-708) |
| 10 Cup, Tapered Roller Bearing | 24 Cover, Gear Case |
| 11 Stud, Threaded 3/8-16 | 25 Capscrew - 5/16-18 x 3/4 |
| 12 Seal, Oil | 26 Washer, Lock 5/16 |
| 13 Seal, Oil | NI Lube, Worm Gear, H.D. 16 oz. |
| 14 Case, Gear | |

Fig. 8-19

POWERPACKER PLUS

BLOWER REMOVAL

(Fig. 8-20, 8-21 & 8-22)

1. Remove wing nuts & washers (A) securing belt guard (B) to blower housing. Remove the guard.
2. Loosen belt adjuster by loosening jam nut & capscrew (C).
3. Remove belt from pulleys.
4. Unhook rubber latch & remove chute assembly (D).
5. Remove (4) 5/16-18 nuts (E) from blower housing (F) & support bracket (G). Blower housing should now be loose.

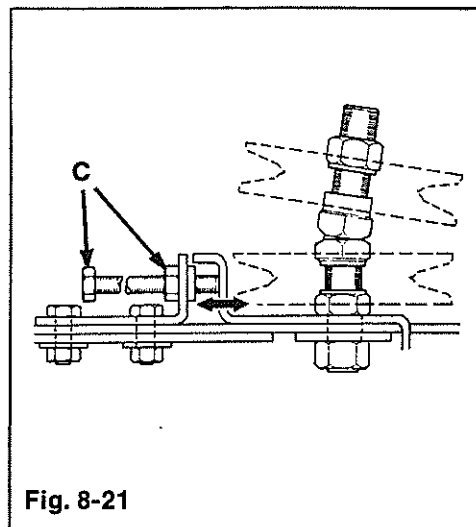
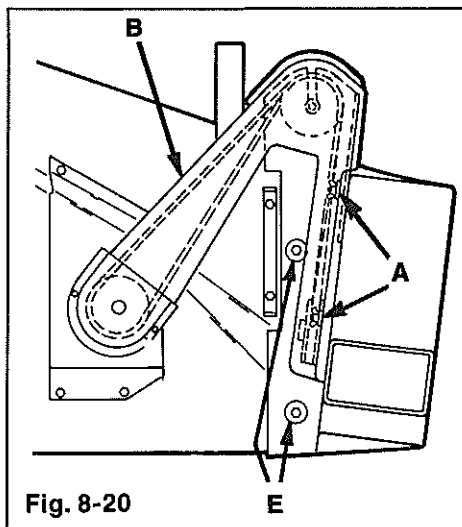

BLOWER DISASSEMBLY

(Fig. 8-22, 8-23 & 8-24)

1. Remove mounting frame (H) from blower housing (F) by removing the 5/6-18 nuts & flange bolts (E).
2. Remove pulley (I) from impeller shaft (J).
3. Remove bearing flanges & bearings (K) from blower housing (F).
4. Remove impeller shaft (J) by driving through either side of blower housing.
5. Remove inner flangette (L) from blower housing.
6. Remove impeller fan (M) by prying through opening of blower housing. Fan should be indexed with opening as shown. Applying heat (hair dryer) may be necessary at location (N), so housing will be more pliable.
7. Remove outer flangette (O).

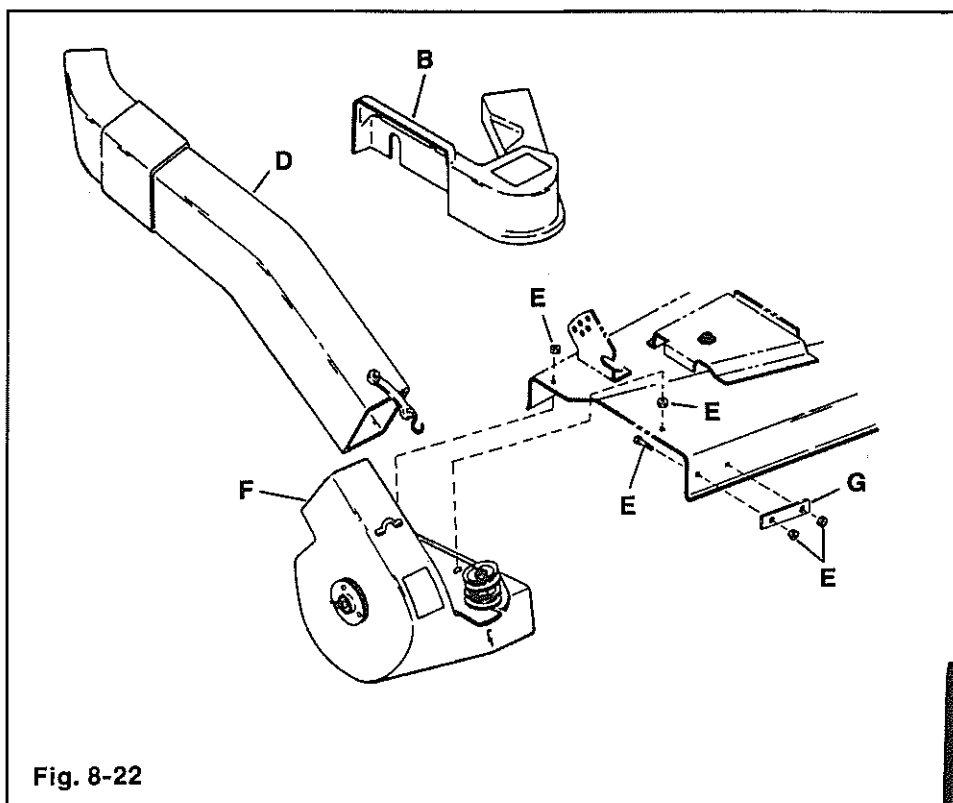

POWERPACKER PLUS (CONT'D)

BLOWER ASSEMBLY (Fig. 8-23)

1. Install outer flangette (O).
2. Install impeller fan (M) through opening in blower housing. Reverse step 6 in BLOWER DISASSEMBLY.
3. Install impeller shaft (J) through impeller fan. Install key (P).
4. Install inner flangette (L).
5. Install washers (Q) to impeller shaft.
6. Install bearing flanges & bearings (L) to blower housing.
7. Install key (R) to exposed shaft. Install pulley (I).
8. Install mounting frame assy. (H) to blower housing.

BLOWER RE-INSTALLATION (Fig. 8-23, 8-24 & 8-25)

1. Re-install blower assembly (F) to mower deck. Reverse step 5 in BLOWER REMOVAL.
2. Re-install chute assembly (D).
3. Install belt & adjust. Fig. 8-21 & 8-25.
4. Re-install belt guard Fig. 8-20.
5. Test run unit.

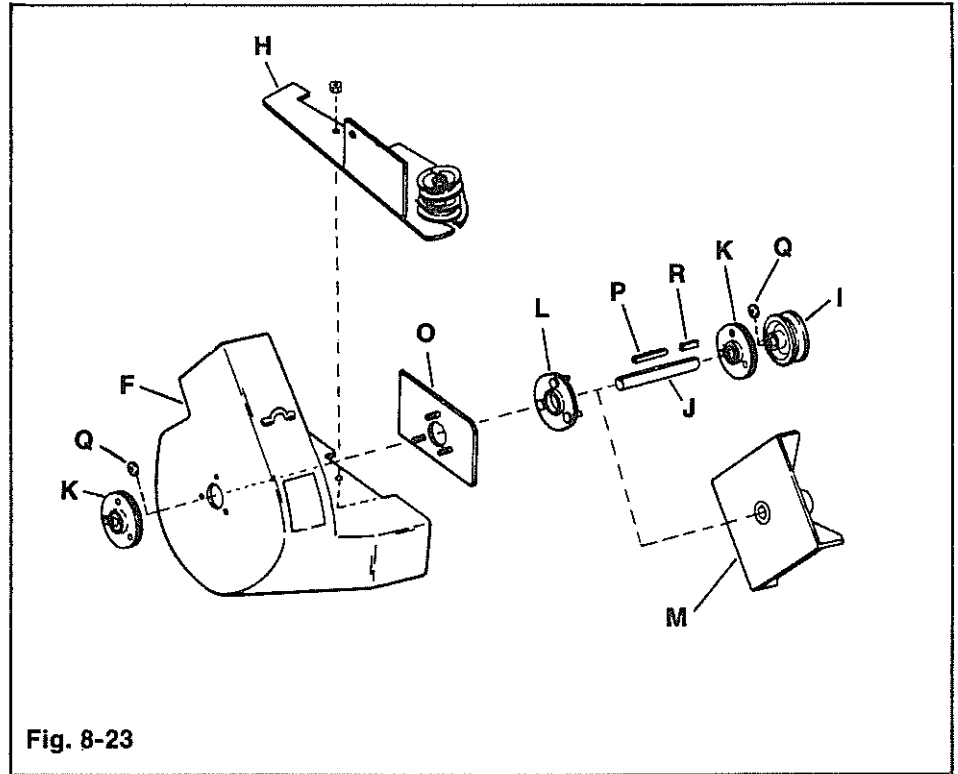

Fig. 8-23

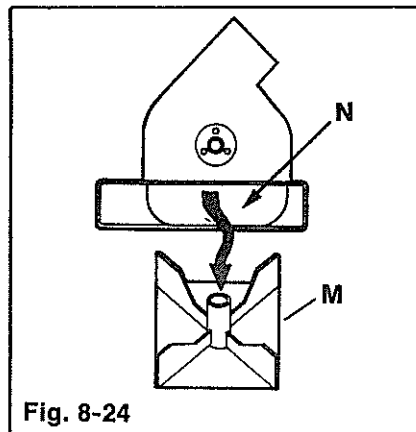

Fig. 8-24

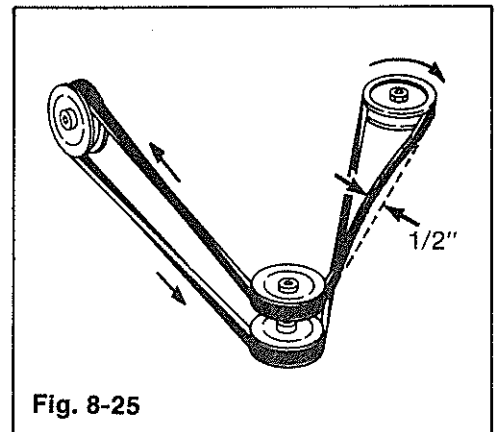

Fig. 8-25

Free Manuals Download Website

<http://myh66.com>

<http://usermanuals.us>

<http://www.somanuals.com>

<http://www.4manuals.cc>

<http://www.manual-lib.com>

<http://www.404manual.com>

<http://www.luxmanual.com>

<http://aubethermostatmanual.com>

Golf course search by state

<http://golfingnear.com>

Email search by domain

<http://emailbydomain.com>

Auto manuals search

<http://auto.somanuals.com>

TV manuals search

<http://tv.somanuals.com>