

MIC400 PTZ Camera Series

Bosch Security Systems

EN | Installation and Operation Manual



BOSCH
Invented for life

MIC400 PTZ Camera Series

Installation and Operation Manual

For the MIC400AL, MIC400UL, MIC400ST, MIC400UT,
MIC400PA and MIC400IR PTZ camera models

Chapters

1. Introduction
2. Hardware Installation
3. Power Supply Installation & Setup
4. Configuring the MIC400 Camera
5. Technical Specifications

Introduction.....	1-12	Configuring the MIC400 Camera.....	4-27
MIC400 PTZ Camera.....	1-6	Connecting the MIC to a PC.....	4-27
MIC400 Versions and Options.....	1-7	Commissioning the MIC through Camset.....	4-27
MIC400 Power Supply Option Versions and Options.....	1-7	Connecting the Greenwich adaptor.....	4-27
Features.....	1-8	Connecting the K2-ADE Adaptor.....	4-28
Unpacking.....	1-9	Connecting the MIC-USB485 Converter.....	4-29
Package Contents.....	1-9	MIC-USB485 Converter and Universal Camset Software Installation.....	4-30
Installation Environment.....	1-10	Commissioning the MIC400 camera with Universal Camset.....	4-30
Associated Equipment.....	1-12	Standard Controls.....	4-30
Hardware Installation.....	2-12	Boot Messaging.....	4-31
Installation Instructions.....	2-12	MIC Settings.....	4-31
Earthing Instructions.....	2-13	Camset Settings.....	4-32
Lightning Protection.....	2-13	Manual Controls.....	4-33
Underwater Installation.....	2-13	Pan, Tilt and Zoom Controls.....	4-33
Electrical Connections.....	2-14	Iris Controls.....	4-33
Power Supply Installation and Setup.....	3-14	Focus Controls.....	4-33
Non-IR Power Supply Units.....	3-14	Auxiliaries.....	4-34
MIC-240PSU, MIC-024PSU and MIC115PSU.....	3-14	Preset Positions.....	4-34
PCB Earth Link.....	3-15	Tour Controls.....	4-35
Power Supply layout and connections.....	3-15	Softstops and No Dwell Zones.....	4-35
Fuse Ratings.....	3-16	MIC Setups.....	4-36
Installation Instructions.....	3-17	General Settings.....	4-36
MIC-12PSU.....	3-18	AutoHome Controls.....	4-37
12 volt or 24 Volt vehicle supply.....	3-18	Other Controls.....	4-38
Power Supply layout and connections.....	3-18	Default Settings.....	4-38
Optional cards and kits for non-IR MIC400 Cameras.....	3-19	MultiAlarm Settings.....	4-39
Commissioning MIC PA and MIC400's with Heaters.....	3-19	Lens Recalibration and Frame Integration.....	4-40
MIC400IR Power Supply Units.....	3-21	Privacy and Captions.....	4-40
Setting the power supply link options.....	3-21	Privacy Controls.....	4-41
Fuse Ratings.....	3-22	Privacy Calibration.....	4-42
Power Supply layout and connections.....	3-22	Captions.....	4-42
Installation Instructions.....	3-23	Thermal.....	4-43
MIC400IR PSU.....	3-24	Advanced Settings.....	4-44
Power Supply layout and connections.....	3-25	MIC Serial Number.....	4-44
Installation Instructions.....	3-26	EEPROM Copier.....	4-45
Commissioning the IR Lamps.....	3-27	Re-Map Auxiliary (Pelco Protocol Only).....	4-45
		Menu Control (Panasonic Protocol Only).....	4-46
		Matrix Controls.....	4-46
		POT Test.....	4-46



POT Test Controls..... 4-47
 POT Test Results..... 4-47
 Comms..... 4-48
 Send Direct Command..... 4-48
 Communications Testing..... 4-49
 SonySet..... 4-50
 SonySet Controls..... 4-50
 The SonySet Table..... 4-51
 MIC Programmer..... 4-53

Technical Specifications..... 5-55
 Technical Specifications..... 5-55
 MIC400AL..... 5-55
 MIC400PA..... 5-57
 MIC400UL and UT..... 5-58
 MIC400S..... 5-59
 MIC400IR..... 5-60
 Dimension Drawings..... 5-61

Safety Precautions

The following symbols are used throughout this manual please pay careful attention to their meaning.



The lightning flash with an arrowhead symbol within a triangle is intended to alert the user to the presence of non-insulated “dangerous voltage” within the product’s enclosure that may be of sufficient magnitude to constitute a risk of electric shock to persons.



The exclamation point within a triangle is intended to alert the user to the presence of important safety, operating and maintenance (servicing) instructions in the literature accompanying the appliance.

Important Safety Instructions



CAUTION
 TO REDUCE THE RISK OF ELECTRICAL SHOCK, DISCONNECT POWER SUPPLY BEFORE OPENING THE POWER SUPPLY UNIT.
 POWER DISCONNECT: POWER SUPPLY UNITS HAVE POWER SUPPLIED WHENEVER THE POWER CORD IS INSERTED INTO THE POWER SOURCE



WARNING
 INSTALLATION SHOULD BE CARRIED OUT BY QUALIFIED PERSONNEL ONLY IN ACCORDANCE WITH THE APPLICABLE LOCAL CODES.
 BOSCH SECURITY SYSTEMS ACCEPT NO LIABILITY FOR ANY DAMAGES OR LOSSES CAUSED DUE TO INCORRECT OR IMPROPER INSTALLATION



IMPORTANT SAFETY INSTRUCTIONS

1. Read these instructions
2. Keep these instructions
3. Heed all warnings
4. Follow all instructions
5. Install according to manufacturer's instructions
6. Do not install near any strong heat sources such as furnaces
7. Do not open the camera unit, doing so invalidates the unit's warranty
8. Do not back-drive the pan or tilt axis of the camera. To do so will damage the motor drive gear chain and will invalidate the warranty
9. Do not use caustic or abrasive cleaning products on the unit
10. Do not point the MIC400 camera at the sun. BOSCH Group will not be liable for any damages to cameras which have been directly pointed at the sun
11. In situations where there could be a risk of injury should any part of the assembly become detached for any reason and fall, normal common sense safety precautions should be employed; a strong safety chain between the camera pan shaft and the mounting surface is recommended
12. For transportation please rotate the ball so the window points towards the base, this helps to protect the wiper & windows during transit
13. Ensure that the product case is properly earthed. If the product is likely to be struck by lightning, ensure that earth-bonding connections are made correctly to the mounting base of the unit
14. Use only the power sources indicated in this user guide and ensure that the current rating of the supply cable is adequate for the product
15. Do not stand canted (45°) MIC400's upright as they can be easily knocked over, lay them on their side.

This product complies with the following EC directives:-

EMC Directive (89/336/EC as amended)

Machinery Directive (98/37/EC)

LV Directive (73/23/EC)

RoHS (Restriction of Hazardous Substances) 2002/95/EC

WEEE (Waste Electrical & Electronic Equipment) 2002/96/EC



This equipment contains electrical or electronic components that must be recycled properly to comply with Directive 2002/96/EC of the European Union regarding the disposal of waste electrical and electronic equipment (WEEE). Contact your local supplier for procedures for recycling this equipment.



Reference

Glossary of Terms

PTZ	-	Pan/Tilt/Zoom
Bi-phase	-	Bosch Bi-phase telemetry protocol (see pg8)
PSU	-	Power Supply Unit
IR	-	Infra Red
BP3, 4	-	Bi-phase converter cards for MIC400 cameras
STP	-	Shielded Twisted Pair cable

Glossary of Tables

Table A	-	MIC composite cable pin table
Table B	-	Power connection to Header HD1
Table C	-	Composite cable to Power Supply HD-3
Table D	-	Telemetry Connections to HD3, HD4 and HD5
Table E	-	Auxiliary connections (Washer Pump Drive) to HD6
Table F	-	Fuse ratings for MIC-240PSU, MIC-24PSU, MIC-115PSU
Table G	-	Power Input wiring connections for MIC-12PSU - HD1
Table H	-	Fuse ratings for MIC-SLIM240 and MIC-SLIM115PSU
Table I	-	Fuse ratings for MIC-IR-240PSU
Table J	-	Alarm Input header for MIC-IR Power Supplies HD2
Table K	-	IR Lamp Connections HD6
Table L	-	Washer Pump Connection HD7
Table M	-	Fuse ratings for MIC-IR-12PSU
Table N	-	Connecting the Greenwich Adaptor
Table O	-	K2-ADE Adaptor Connection
Table P	-	Camera Interface Control Settings
Table Q	-	MIC-USB485CVTR Connection table and Diagram
Table R	-	Sony Set Commands

Appendices

Appendix A	-	Protocol Preset Commands
------------	---	--------------------------

CHAPTER 1

Introduction

The MIC400 family of PTZ cameras are BOSCH Group's current range of weatherproof, ruggedized, high specification, fully functional pan tilt zoom CCTV cameras.

The MIC400 series has been designed to offer an extremely reliable, robust and high quality surveillance solution for security applications that demand the very best performance. Precision engineered to exacting standards, the range offers numerous benefits over the use of traditional dome and PTZ cameras and comes with a variety of options in order to offer a best fit solution for virtually any application.

Rated to an industry leading IP68, the compact vandal resistant 6mm thick aluminium camera housing is suitable for installation in the harshest of environments, while the optically perfect flat viewing window and integrated wiper option ensure razor sharp images are captured in even the most demanding conditions.

Brushless motor technology ensures ultra-reliable, whisper quiet operation while groundbreaking resolver technology provides pin-point accuracy and affords the user full 360° continuous rotation pan and an unprecedented 320° tilt control.

A choice of true day/night camera modules, offering up to 36x optical zoom (12x digital), coupled with flexible upright or inverted mounting capability, allows the perfect field of view to be achieved every time.



MIC400 Camera Versions and Options

MIC400 Camera Versions

This manual covers the installation & operation of the following MIC400 series PTZ cameras, briefly described below:-

MIC400AL The MIC400AL is made from machined and cast aluminium and is then pre-treated and painted with two part epoxy power coat paint in either RAL7001 (Grey) or RAL9005 (Jet Black). This is the basic MIC model and is available with optional wipers, heaters, 8-input alarm card and washer pump kit.

MIC400IR This is the MIC400AL camera fitted with powerful twin IR lamps that illuminate to 55M. Available options include the wiper and washer pump kit. The MIC-IR power supplies feature a built in washer pump drive function and 4 alarm inputs as standard, heaters cannot be fitted to the MIC400IR.

MIC400PA The MIC400AL camera is fitted with twin PA speakers that can be used for public address applications. Available options include the wiper, 8-input alarm card and washer pump kit; heaters cannot be fitted to the MIC400PA.

MIC400UL The MIC400UL is fitted with special seals to allow continual submersion in water to a depth of 30m. Available options include heaters and the 8 input alarm card. A wiper cannot be fitted to the MIC400UL.

MIC400ST The MIC400 is also available in machined 316 Stainless Steel for additional strength and corrosion resistance. Available options include a wiper, heaters, 8 input alarm card and washer pump kit.

MIC400UT The MIC400UT is fitted with special seals to allow continual submersion in water to a depth of 25m with enhanced corrosion resistance. Available options include heaters and the 8 input alarm card. A wiper cannot be fitted to the MIC400UT.

MIC400 Power Supply Unit Versions and Options



CAUTION: Do not use IR power supplies with non IR cameras, or damage to the MIC400 unit will occur.

BOSCH Group has designed a range of power supplies for the MIC400 cameras to cater for a variety of common voltages and provide all the connections needed for power, telemetry and video. The power supply units and options are detailed below.

For cameras without IR lamps only:-

MIC-240PSU	240Vac input Power Supply Unit
MIC-115PSU	115Vac input Power Supply Unit
MIC-24PSU	24Vac Input Power Supply Unit
MIC-12PSU	12Vdc Input Power Supply Unit for vehicle installation

For MIC400IR cameras only:-

MIC-IR-240PSU	240Vac input Power Supply Unit
MIC-IR-115PSU	115Vac input Power Supply Unit
MIC-IR-12PSU	12Vdc input Power Supply Unit for vehicle installation



	MIC400 Camera and PSU compatibility chart					
	MIC-400AL	MIC-400PA	MIC-400UL	MIC-400ST	MIC-400UT	MIC-400IR
MIC Power Supply						
MIC-240PSU	✓	✓	✓	✓	✓	✗
MIC-115PSU	✓	✓	✓	✓	✓	✗
MIC-24PSU	✓	✓	✓	✓	✓	✗
MIC-12PSU	✓	✓	✓	✓	✓	✗
MIC-IR-240PSU	✗	✗	✗	✗	✗	✓
MIC-IR-115PSU	✗	✗	✗	✗	✗	✓
MIC-IR-12PSU	✗	✗	✗	✗	✗	✓

Other options include the following:-

Wiper	A rubber wiper blade mounted on a spring loaded arm is available for most MIC400 versions
Heater	Two (2) 10w heaters can be fitted to most MIC400 versions giving improved low temperature performance down to -30°C
MIC-WKT	Washer bracket, nozzle and washer pump drive card kit for non-ir cameras
MIC-WKT-IR	Washer bracket and nozzle kit for MIC400IR
MIC-ALM	An 8-input alarm card for non-ir cameras, includes washer pump drive function
MIC-BP3	Bosch Bi-phase converter card for power supplies without expansion slots available, including all IR psu's
MIC-BP4	Bosch Bi-phase converter card for power supplies with an expansion slot available.

The permissible combination of options are summarised in the following table.

Options	MIC400 Camera and Options compatibility chart					
	MIC-400AL	MIC-400PA	MIC-400UL	MIC-400ST	MIC-400UT	MIC-400IR
Wiper	✓	✓	✗	✓	✗	✓
Heater	✓	✗	✓	✓	✓	✗
MIC-ALM	✓	✓	✓	✓	✓	✗
MIC-WKT	✓	✓	✗	✓	✗	✗
MIC-WKT-IR	✗	✗	✗	✗	✗	✓
MIC-BP3	✗	✗	✗	✗	✗	✓
MIC-BP4	✓	✓	✓	✓	✓	✗

The permissible combination of options are summarised in the following table.

Features

The MIC400 series cameras have the following features:

- Brushless Motor Technology for whisper quiet operation.
- Large protocol selection available for easy integration
- Canting option to allow bottom of pole vision
- Choice of 18x or 36x camera modules
- Wide range of mounting options for varied applications
- Optically flat viewing window



Unpacking



CAUTION Ensure canted (45°) MIC400's are laid on their side; do not stand upright as they are unstable.

WARNING: Take extra care lifting or moving Stainless Steel units due to their weight.

- Check the exterior of the packaging for visible damage. If any items appear to have been damaged in transit please inform the shipping company.
- Unpack the power supply unit carefully; although ruggedized this is electronic equipment & should be handled with care.
- Do not use if any component appears to be damaged. Please contact Bosch Security Systems CCTV Ltd in the event of damaged goods.
- The shipping carton is the best way to transport the unit, save it & all other packaging materials for future use. If the unit must be returned, use the original packing materials.

Packaging Contents

Please check for the following contents

- MIC400 Installation & Operation manual (this guide)
- Installation & Configuration CD
- Quick start reference sheet



Installation Environment



CAUTION: Ensure all local safety codes are observed when installing this product; ensure a strong safety chain is used to secure the MIC400 camera to prevent any danger of dropping the product during installation. Particular care should be taken with Stainless Steel models due to the additional weight.

The MIC400 range has been designed to be easily installed on a variety of common fittings. Most commonly a dedicated CCTV camera pole is used, the MIC400 will bolt directly to the top of most poles using the industry standard 4" (101.6mm) fitting. Such camera poles provide robust mounting platforms that minimize camera motion and typically have large base cabinets to mount all ancillary equipment such as power supplies.

The MIC400 cameras can also be mounted on lamp post columns using the Pole Mount Bracket (MIC-PMB) however users should be aware that lamp posts can often be subject to movement and are not suitable platforms in all conditions or for all applications.

For mounting directly onto buildings Bosch Security Systems manufacture a range of brackets suitable for all typical building installations for upright (90°), canted (45°) or Inverted camera positions, examples are shown below.

MIC-SCA
Shallow Conduit Adaptor

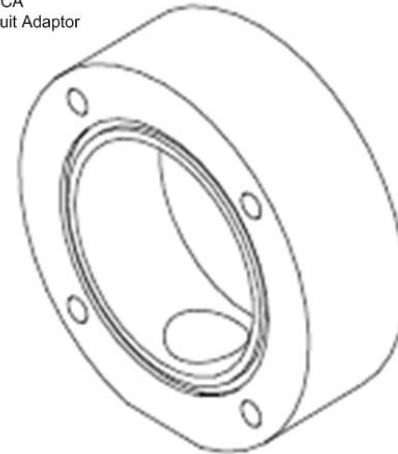

MIC-DCA
Deep Conduit Adaptor

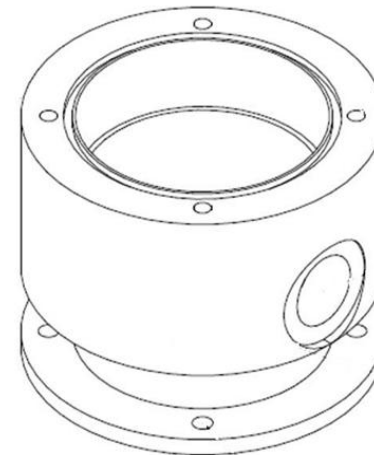

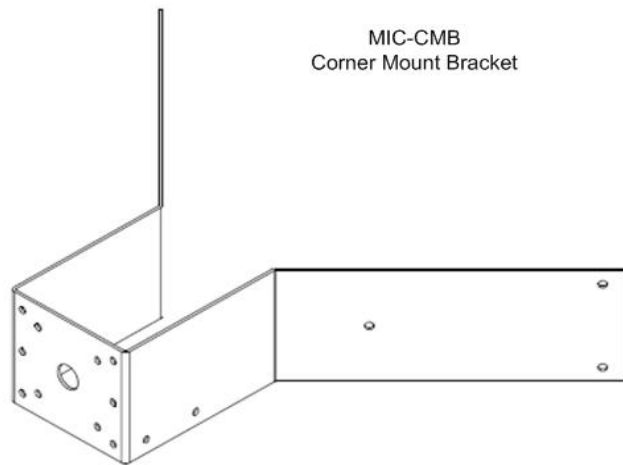
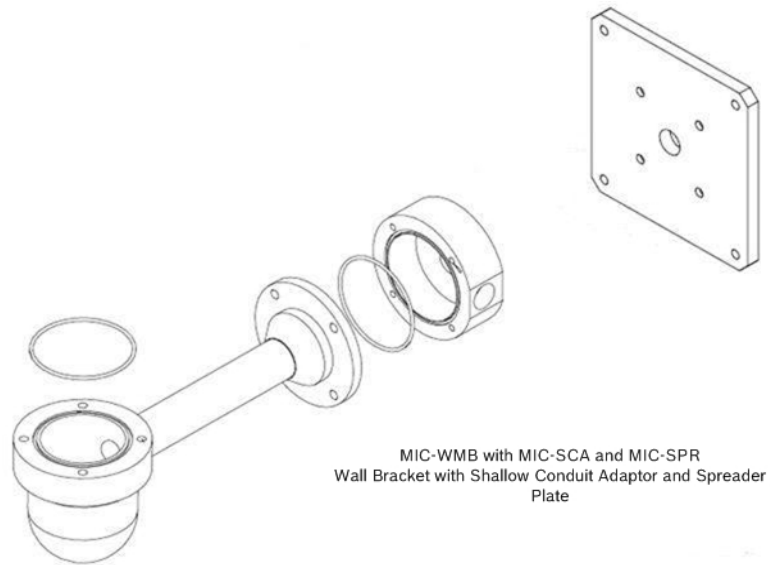

MIC-PMB with MIC-SCA and MIC-WMB
Pole Mount Bracket with Shallow Conduit
Adaptor and Wall Bracket

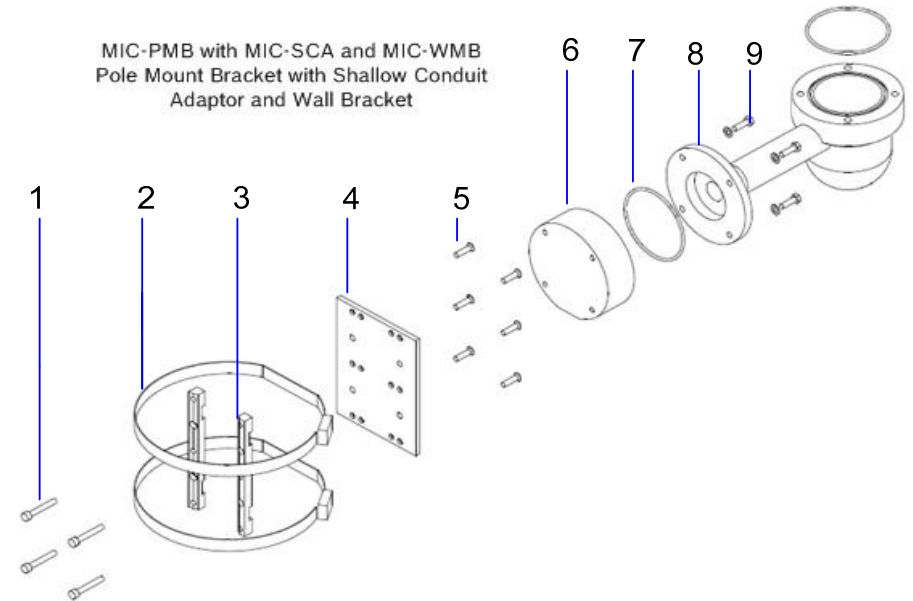

Key to MIC-PMB drawing

1. Securing bolts for MIC-SCA
2. 90mm stainless steel pole banding
3. Pole mount bracket blocks
4. Pole mount bracket plate
5. Pole mount block securing securing bolts
6. Shallow conduit adaptor
7. "O"-ring
8. Wall mount bracket
9. Wall mount bracket securing bolts

Associated Equipment & Typical Installations

The robust nature of the MIC400 range of cameras make it ideal for installation in all typical domestic and commercial CCTV applications such as residential homes, shopping centres, commercial premises, military/ government installations, ports & airports to name but a few.

The MIC400's adaptability enables easy integration in a wide variety of mobile and re-deployable installations these have included Lifeboats & other surface/subsurface vessels, Emergency service vehicles, Highways Agency vehicles, Council/Contractor parking enforcement vehicles & Crowd control vehicles.

The MIC400 uses a composite cable to carry all power & telemetry between the camera head and the MIC power supply unit this cable can be a maximum of 25m long, for installations which require the camera head to be more than 25m from the power supply then it is recommended that a 2m cable be connected to a junction box from which telemetry; video and power can be broken out into separate cables and appropriate wiring used to extend the distance to suit.

CHAPTER 2 Hardware Installation



CAUTION: Ensure all local safety codes are observed when installing this product; ensure a strong safety chain is used to secure the MIC400 camera to prevent any danger of dropping the product during installation. Particular care should be taken with Stainless Steel models due to the additional weight.

Installation Instructions

1. Locate the mounting position of the camera so that it cannot be interfered with either intentionally or accidentally.
2. Ensure the mounting surface is capable of supporting the combined weight of the camera and mounting hardware under all expected conditions of load, vibration and temperature.
3. Fit the mounting brackets securely, observing all appropriate safety precautions & local building regulations.
4. Ensure that the mating 12-pin connector is fitted properly in the camera plug. Confirm that the 25mm connector sleeve on the top of the composite cable is done up tightly (approx. four turns from start of thread engagement).
5. Earth the camera using one of the securing bolts. Only earth the camera at a single point to prevent earth loops & hum bars.
6. M8 x20mm Stainless steel nuts, bolts and washers should be used to secure the cameras 4" PCD base to the mounting bracket. An additional Nebar gasket or suitable silicone sealant can be used to ensure a water tight seal between the 4" PCD base & mounting surface. Ensure all bolts are securely tightened. Secure all cabling & conduit.





CAUTION: If the camera is mounted ball down it is essential that the connector and base area of the camera are completely sealed from water ingress.

CAUTION: Any water getting into the connector is liable to cause corrosion to the connector pins leading to unreliable operation of the camera unit.

CAUTION: To prevent water penetrating the composite cable connector threads, the 25mm thread should be sealed at final installation using PTFE tape. Alternatively a suitable sealant may be liberally applied to the thread prior to final tightening.

Earthing of the MIC400 camera

1. The camera module & housing are electrically isolated so the housing should be safety earthed regardless. The safety earth should be a bonding connection to the cameras outside case for example one of the securing bolts.
2. The camera should be earthed at one point only to prevent earth loops & thus hum bars showing on the control room monitor.
3. If the system is copper throughout & the camera pictures are fed back to the control room coaxial copper cable, then the camera should be earthed at the video termination point in the control room & nowhere else. In this case the PCB "Earth Link" should be broken.
4. If the video is transmitted back to the control room via some non electrical connecting medium, e.g. fibre optic, radio or microwave link, then the camera should be earthed at the transmitter point in the psu. The PSU "Earth Link" may be used for this purpose.
5. If dual earthing is unavoidable then a video isolation transformer should be fitted between the two earths.

Lightning Protection

If the camera is fitted in a highly exposed place then consideration should be given to lightning protection. A good earth bonding connection to the case itself will provide protection against damage from secondary strikes.

Where there is a risk of a primary strike hitting the camera housing directly, it is recommended that a separate lightning conductor be fitted within 0.5m of the camera and at least 1.5m higher than the camera.

The construction of the housing itself is very capable of coping with secondary strikes and no damage to the internal electronics or camera should result if correct lightning protection is applied.

Underwater Installation

The MIC400 series are IP68 rated units, excepting the MIC400PA speakers which are IP67, this allows complete submersion in water to a depth of 1M. The MIC400UL and MIC400UT models allow submersion to a maximum depth of 25M due to the special seals fitted to these models.



CAUTION: It is the responsibility of the installer to ensure the correct water proof conduit glands, conduit and gaskets/sealants are used for the installation to ensure no water enters the cameras base and reaches the composite cable connector. Failure to ensure a water free connector will lead to corrosion of the camera connector and to camera failure. Care must also be taken to ensure that any sealants used are non toxic to marine life.

Typically the MIC400UL an MIC400UT are mounted inverted on a Deep Conduit Adaptor fitted to the base, additional sealant or gaskets are applied to the joint of the camera foot and the Deep Conduit Adaptor to ensure a watertight seal.

A suitable waterproof conduit gland and conduit is then used to carry the composite cable to the surface for installation in the power supply. Wall Mount Brackets (MIC-WMB) can also be used to mount the MIC400 underwater following the same precautions as outlined above.



Electrical Connections



WARNING: Electrical Danger: Ensure all power is disconnected before opening or working upon the Power Supply Unit. Installation must be carried out by suitably qualified persons.

A purpose built composite cable for use with the camera is available; these cables are pre-made with a Female terminated 12 way connector fitted to them for attachment to the Male connector installed into the base of the camera. The composite cable has no termination (free wires) at the other end for wiring into the appropriate power supply. The standard colour coding used in these cables is as shown below.

Table A – MIC Composite Cable Pin table

MIC400 Connector Pin	Signal Name	Cable Wire Colour
A	Video Output	Coax core
B	Video Return	Coax screen
C	Tamper Sw	Black
D	Tamper Sw Rtn	Brown
E	Washer drive Rtn	Grey
F	Washer drive	Orange
G	Full Duplex Tx A.	Blue
H	Full Duplex Tx B.	Violet
J	Full Duplex Rx A. Half Duplex Tx/Rx A.	Yellow
K	Full Duplex Rx B. Half Duplex Tx/Rx B.	White
L	Power input 1.	Red
M	Power input 2.	Green

CHAPTER 3 Power Supply Installation & Setup

The Power Supply Units provide all the support functions for connecting the MIC400 cameras to third party equipment, they comprise of:

NON-IR Power Supply Units

MIC-240PSU, MIC-24PSU and MIC-115 PSU

The power supply provides power for a single MIC400 non-ir camera unit from either a 240v AC source (MIC-240PSU), a 24v AC (MIC-024PSU) or a 115v AC source (MIC-115PSU). The transformer fitted to these designs is a thermally protected transformer that automatically cuts out if the transformer core temperature exceeds 40 Degrees C. On cooling the transformer will become operational again.

In addition the unit provides all the terminations required to connect a MIC400 camera to third party equipment.

A second independent 12v (600mA) power supply is also included to drive any internally fitted optional interface cards.

Dimensions

Power supply enclosure:-225mm (W) x 70mm (H) x 195mm (D)

The Power Supply Unit provides all the support functions for connecting the camera to third party equipment. It comprises of:

- 1) A weather resistant (IP55) plastic box fitted with four cable glands.
- 2) A power supply for the MIC400 camera.
- 3) A second power supply for driving various interface cards mounted internally to the power supply box. e.g. washer drive card, alarm interface card.
- 4) Provision for a signal interface card, to connect telemetry to third party equipment.
- 5) Screw termination of all cable into and out of the box.
- 6) Correct video termination for the camera coaxial cable.
- 7) Earth isolation and termination within the unit to correctly control Video earthing and thus prevent Earth loop.



PCB Earth Link

The PCB has one link option next to HD1 to allow the power supply to be set up for different earthing schemes: The Earth Link should be broken if there is a separate connection between video screen and earth. Usually occurs on copper connected systems where all the copper video coaxes are taken back to the control room to be connected to a central earth point. If fibre optics or other indirect connections are used to get data and video to and from the control room then the earth link should be left intact provided it is the only camera end earth reference point.

Power Supply Layout and Connections

The Power supply PCB has the following connections as shown on Figure A:-

- HD1 – Power Input Connector (screw terminal)
- HD2 - Tamper Switch header (screw terminal)
- HD3 - Composite cable header (Connections to camera head, screw terminal)
- HD4 - Telemetry header (Molex Connection)
- HD5 - Telemetry header (screw terminal)
- HD6 - Washer pump header (screw terminal)
- HD8 - Keyboard power connector (demo purposes only, not normally fitted)
- CN1 - Video out connection header (BNC)
- CN2 - Add on card header (plug in)

Figure A and the following tables show the connections required.

Figure A - MIC-240PSU Layout

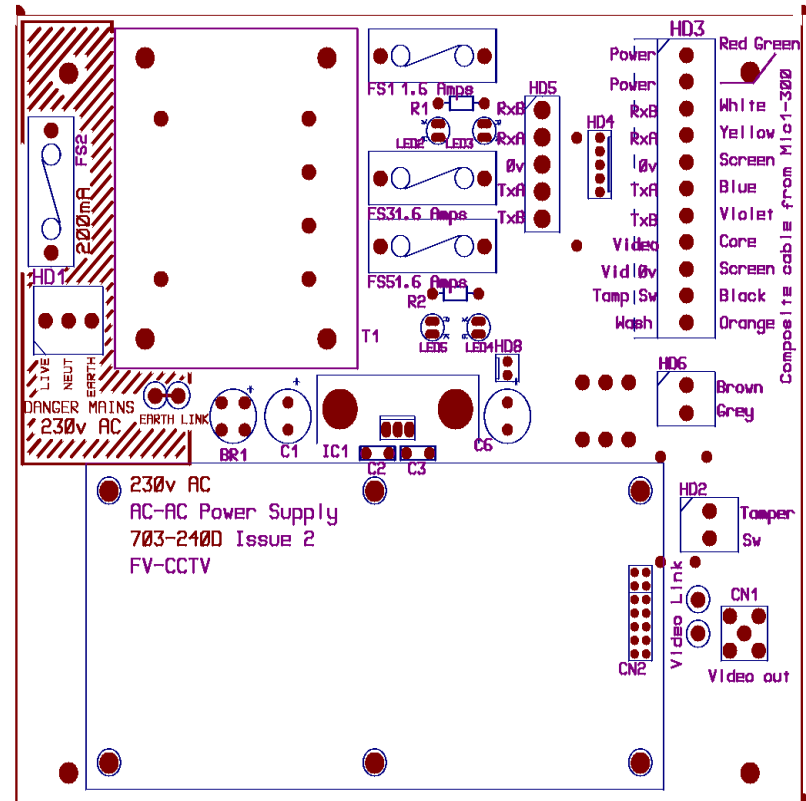

Table B – Power Connection to Header HD1

Live	HD1-1
Neutral	HD1-2
Earth	HD1-3



Table C - Composite cable to Power Supply HD-3 Connection Table

Composite Cable Wire Colour	Function	Terminal Box Connector	Terminal box ID marking
Red	AC supply	HD3-1	Power
Green	AC supply rtn.	HD3-2	Power
White	Rx +	HD3-3	RxB
Yellow	Rx -	HD3-4	RxA
Drain Wire	Gnd	HD3-5	GND
Blue	Tx -	HD3-6	TxA
Violet	Tx +	HD3-7	TxB
Coax Core	Video	HD3-8	Video
Coax Screen	Video Return	HD3-9	Vid 0v
Black (Optional)	Tamper Switch	HD3-10	Tamp Sw
Orange (Optional)	Wash drive	HD3-11	Wash

Table D –Telemetry Connections to HD3, HD4 and HD5

Telemetry Signal Name	HD3	HD4	HD5
RXB or Rx +	Pin 3	Pin 1	Pin 1
RXA or Rx -	Pin 4	Pin 2	Pin 2
GND	Pin 5	Pin 3	Pin 3
TXA or Tx -	Pin 6	Pin 4	Pin 4
TXB or Tx +	Pin 7	Pin 5	Pin 5

Table E –Auxiliary connections (IR Lamps, PA Speakers and Heaters) to HD6

Composite cable Wire colour	Function	Terminal Box Connector
Brown	Heater* or IR Lamps** or PA speakers***	HD6-1
Grey	Heater* or IR Lamps** or PA speakers***	HD6-2

*See page 19 for details on commissioning MIC400 cameras with the heater option fitted.

**IR power supplies only, see MIC-IR Power Supplies on page for more details.

*** See page 19 for details on connecting the PA speakers.



CAUTION: Connecting MIC400IR or MIC400PA units to a MIC-PSU with the heater option enabled as this can result in damage to the cameras. Please ensure that the heater link is disabled if a MIC400PA is to be used or ensure a MIC-IR-PSU is used with a MIC400IR camera unit.

Fuse ratings

The power supply houses 4 off 20mm fuses in fuse holders. The ratings for these fuses if fixed on the low voltage secondary side but changes with input voltage on the high voltage primary side.

The following table shows the fuse values fitted for the different supplies for operating the power supply:

Note FS 4 does not exist



Table F – Fuse Ratings for MIC-240PSU, MIC-24PSU and MIC-115PSU

Fuse ident	Fuse function.	Rating for 240v primary	Rating for 115v primary
FS 1	MIC400 protection	1.6A glass Anti surge (T)	1.6A glass Anti surge (T)
FS 2	Primary protection.	200mA ceramic quick blow	500mA ceramic quick blow
FS 3	Heater protection 1	1.6A glass Anti surge (T)	1.6A glass Anti surge (T)
FS 5	Heater protection 2	1.6A glass Anti surge (T)	1.6A glass Anti surge (T)

Installation Instructions

WARNING: Electrical Danger: Ensure all power is disconnected before opening or working upon any Power Supply Unit. Installation must be carried out by suitably qualified persons & all local safety regulations should be followed.

1. Locate the mounting position of the MIC-PSU so that it cannot be interfered with either intentionally or accidentally, a lockable cabinet is recommended.
2. Securely fix the MIC-PSU using M4 stainless steel screws & washers; ensure the cable glands have sufficient room to allow for the cables to enter.
3. Feed all cabling through the appropriate sized gland holes.
4. Connect the composite cable to HD3 following the colour coding as shown in the Table C & printed on the PCB.
5. If a tamper switch relay is to be used, connect this at HD2.
6. Connect the Coaxial video cable to the CN1 header.

7. CN2 is for additional add on cards such as alarm inputs, video processors, Bi-phase cards etc.
8. Telemetry connections are provided by headers HD3, HD4 and HD5 which respectively enable crimp or screw terminations for connecting the MIC400 to the control room as per Table D.
9. Connect the power to HD1 carefully observing the polarity and voltage as per Table B.
10. When wiring is complete, apply power & check the all four (4) LED's are lit.
11. Following Installation when power is applied the following LEDs will light to indicate:-
LED1 – 15vAC power on to camera
LED2 – 15vAC power on camera
LED4 – Power on for optional heater/speaker
LED5 – Power on for optional heater/speaker
12. Re-attach the enclosure lid & screw down until tight.
13. For installation of the MIC-WKT-KIT, MIC-ALM or MIC-BP-4 Bi-phase card please refer to their respective manuals.



MIC-12PSU Power Supply Unit

The power supply provides power for a single MIC400 non-ir camera unit from a 9v DC to 29v DC source for installation of the MIC400 camera on vehicle mounted applications.

Dimensions

Power supply enclosure – 225mm (W) x 70mm (H) x 195mm (D)

This is connected as per the MIC-240PSU as shown previously with the exception of the following changes:-



WARNING: Electrical Danger: Ensure all power is disconnected before opening or working upon any Power Supply Unit. Installation must be carried out by suitably qualified persons & all local safety regulations should be followed. For vehicle mounted installation a specialist installer is recommended.



CAUTION: It is extremely important to observe the correct polarity, failure to do so will result in the destruction of the DC-DC power supply.
CAUTION: This power supply was designed for negative earthed vehicles only it is not suitable for use with positive earth vehicles.

12 or 24 Volt vehicle supply

This should be fed in to connection HD1 nominally marked as mains input, connections should be as follows:-

Table G – Power Input wiring connections for MIC-12PSU

Positive	HD1-1
Negative	HD1-2
Earth and Negative	HD1-3

The rating of fuse FS2 should be changed to a 2A quickblow as opposed to the rating shown on the PCB.

Power Supply Layout and Connections

- HD1 – Power Input Connector (screw terminal)
- HD2 - Keyboard power connector (demo purposes only, not normally fitted)
- HD3 - Composite cable header (Connections to camera head, screw terminal)
- HD4 - Telemetry header (Molex Connection)
- HD5 - Telemetry header (Screw terminal)
- HD6 - Tamper Switch header (Screw terminal)
- HD7 – Washer Pump Drive header (Screw terminal)
- CN1 - Video out connection header (BNC)
- CN2 - Add on card header (plug in)

Figure B – MIC12-PSU Layout

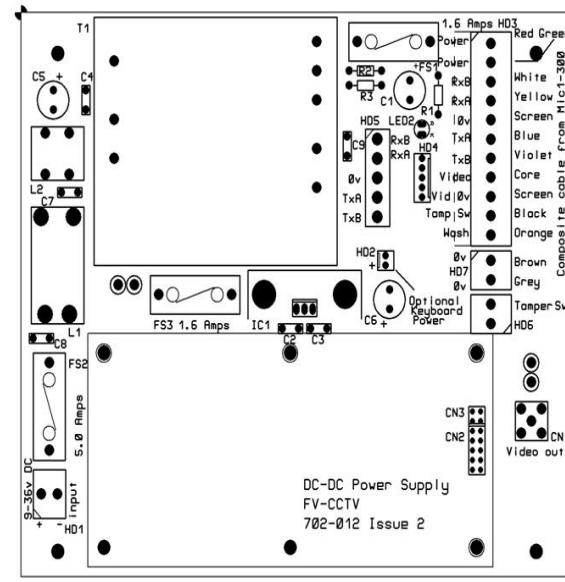

For 12V vehicle installations the composite cable wiring is identical to that shown earlier in this manual on Table C



Optional Cards and Kits for Non-IR MIC400 Cameras

The MIC400 has several optional cards and kits as described earlier.

Please refer to the respective manuals for details on their installation and operation.

MIC-WKT	Washer bracket, nozzle and pump card kit for non-ir cameras
MIC-ALM	8-input alarm card for non-ir cameras, includes washer pump drive function
MIC-BP3	Bosch Bi-phase converter card for MIC-power supplies without an expansion slot available including all IR psu's
MIC-BP4	Bosch Bi-phase converter card for MIC power supplies with an available expansion slot.

Commissioning MIC400PA and MIC400's with heaters fitted.

MIC400PA

The MIC400PA has two (2) 6w, 8ohm, IP67 rated speakers connected in series to allow for public address applications, these utilise the Brown and Grey wires on the composite cable that are normally used for IR illuminators.

There are no connections for speakers on the power supply itself; the speakers are connected directly to a third party amplifier and microphone.

To utilise the speakers please do the following:-

1. Disconnect the power supply from the power source; locate the Brown and Grey wires in the composite cable.
2. Using a terminal block connect the Brown and Grey wires from the speakers.
3. Feed the speaker cable through one of the conduit glands in the PSU enclosure.
4. Connect the speaker cable from a third party amplifier and microphone to permit the speakers to be used.

Heater Option

Applicable to the following power supplies only.

MIC-240PSU, MIC-115PSU, MIC-24PSU and MIC-12PSU only.

There are two links on the power supply printed circuit board which must be changed to allow heater operation. Please do the following to enable the heaters to function:-

1. Disconnect the power supply from the power source; locate the Brown and Grey wires from the composite cable.
2. Locate the PCB links next to HD6, the default setting is 0V (shown below)



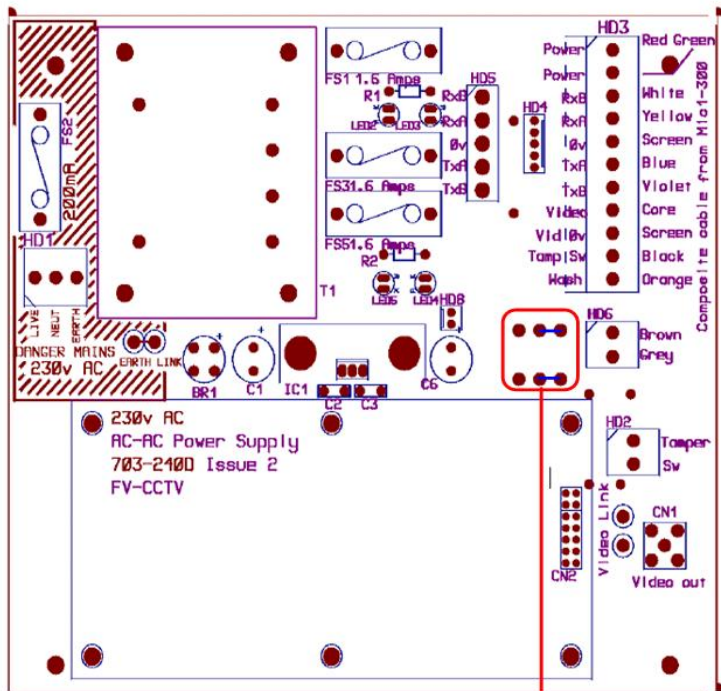

Link set to +0V AC

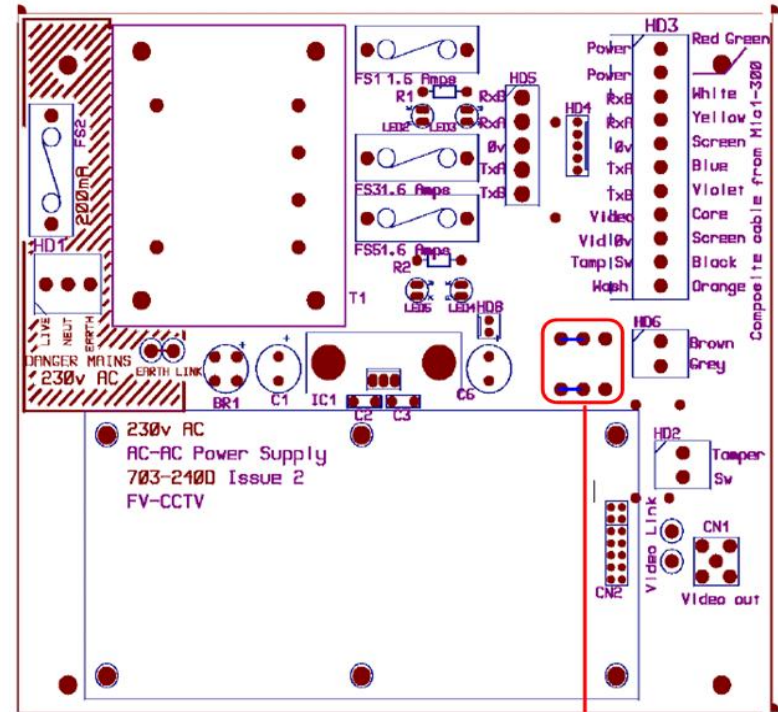

Link set to +15V AC

3. Break the two solder links and trim away excess solder.
4. Solder the links from the left hand pads to the middle pads as shown next.

5. The power supply will now deliver +15vac to HD6.
6. Connect the heater wires Brown and Grey to the HD6 termination header as labelled on the PCB and in.
7. The heaters are thermostatically controlled and will automatically turn on at +5°C and turn off at +15°C.
8. Check all connections, reseal the PSU enclosure and reapply power.

MIC400IR Power Supply Units

MIC-IR-240PSU, MIC-IR-115PSU, MIC-IR-24PSU and MIC-IR-12PSU

The power supplies for the MIC400IR cameras are available in a 230v/115v AC source; a 24v AC source or a 12V DC source

A weather resistant (IP66) box prefitted with four cable glands.

A power supply for the MIC400 camera at 15v AC nominally.

A second isolated power supply for driving the IR illuminators, the operation of this power supply is controlled by the camera itself via telemetry commands received from the control room. The power supply operates with twin illuminators; this drive is a constant current drive which automatically configures itself for IR lamp operation. There are no adjustable items within the power supply except for the three links discussed below.

Screw termination of all third party cables into and out of the box.

Correct video termination for the camera coaxial cable.

Dimensions

Power supply enclosure: - 260mm (W) x 90mm (H) x 120 (D)

The power supply provides a circuit for operating a 230v/115v mains driven washer drive pump and reservoir system.

The power supply also supports 4 volt free alarm contact inputs which can be made to activate presets within the camera but always notifies the control system of the status of these alarms, HD2 provides the option for connection up to 4 alarm inputs to the power supply. These can be tamper switches or inputs from other sensors/switches.

Earth isolation and termination within the unit to correctly control video earthing and thus prevent Earth loop.

Setting the Power Supply Link Options

The PCB has three optional links to allow the power supply to be set up for different installations. If a link change is required this can usually be done with the PCB in place and setting of links using a soldering iron and TCW link wire. The unit is supplied with all links fitted. For the following special functions the associated link should be cut out:

Earth Link 1 (left link) should be broken if there is a separate connection between video screen and earth. Usually occurs on copper connected systems where all the copper video coaxes are taken back to the control room to be connected to a central earth point.

Earth link 2 (right link) should only be cut under special circumstances. This link ensures that the metal case of the power supply is connected to earth. The electronics / video screen earthing is controlled by earth link 1. If required a separate heavy duty earth strap should be fitted to one of the four mounting bolts on the outside of the box.

230v AC/115v AC Link

230v link should be removed and replaced by two separate links linking the two pad pairs shown as 115v links if the power supply is to be run from an 115v AC mains supply.

There are no other adjustable parts on the power supply.

Fuse Ratings

Mains feed to the transformer is protected by FS2 which is rated as a Ceramic fuse at 600mA quick blow. Depending upon the setting of the links to the right of SK1 the terminal box can be supplied from 230v AC or 115v AC. The ident on the PCB defines which links should be soldered into the PCB to achieve the desired voltage. (Factory default is 230v AC).

If there are no other connections to the camera to earth via a locally connected fibre interface unit or via a video/opto transmission system or some other third party equipment, then the left Earth Link situated below FS4 should be left intact.



There are 5 fuses fitted to the power supply. All are 20mm fuses. With the following functions:

Table I – Fuse Ratings for MIC-IR-240PSU

Fuse	Function	Type	Rating
FS1	15v AC secondary fuse. Mic supply.	Glass	1.6A quick blow
FS2	Mains input fuse for transformer.	Ceramic	600mA Quick Blow
FS3	IR Lamp supply fuse.	Glass	2.5A Quick blow.
FS4	Mains fuse for Washer drive.	Ceramic	2Amp Quick Blow.
FS5	15v AC secondary fuse. MIC supply.	Glass	1.6A Quick Blow.



WARNING: Fitting fuses other than the values described above invalidates the product warranty and may result in damage to the product or injury to the installer.
WARNING: 702-241 Issue 2 PCB ident shows FS3 as 1.6 Amps. This ident is in error and the correct value is 2.5Amps.

Power Supply Layout and Connections

- HD1 - Power Input connector (screw terminal)
- HD2 - Alarm Input header (screw terminal)
- HD3 - Composite cable header (Connections to camera head, screw terminal)
- HD4 - Telemetry header (Molex Connection)
- HD5 - Telemetry header (screw terminal)
- HD6 - IR Lamp header (screw terminal)
- HD7 - Washer drive power input header (screw terminal)
- CN1 - Coax Video Header (BNC Connector)
- SK1 - Washer pump drive header (screw terminal)

FIGURE D – MIC-IR-240PSU Layout

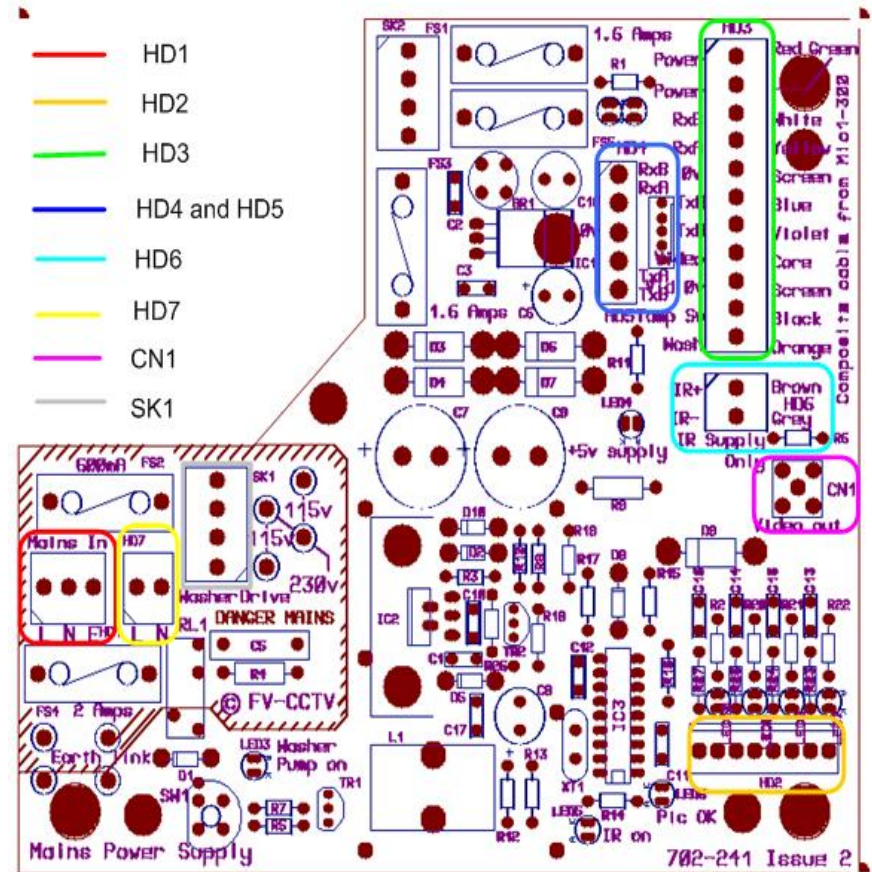

Table J - Alarm Input header for MIC-IR Power Supplies HD2

Connection	Function
HD2 pin 1	Alarm 1
HD2 pin 2	0v
HD2 pin 3	Alarm 2
HD2 pin 4	0v
HD2 pin 5	Alarm 3
HD2 pin 6	0v
HD2 pin 7	Alarm 4
HD2 pin 8	0v

Table K -IR Lamp Connections HD6

Composite cable Wire colour.	Function	Terminal Box Connector	Terminal box ID marking.
Brown	IR Lamp +	HD6-1	IR+
Grey	IR Lamp -	HD6-2	IR-

Table L -Washer Pump Connection HD7

Signal	Connection	Ident
Washer pump Live	HD7 pin 1	L
Washer pump Neutral	HD7 pin 2	N

Installation Instructions



WARNING: Electrical Danger: Ensure all power is disconnected before opening or working upon any Power Supply Unit. Installation must be carried out by suitably qualified persons & all local safety regulations should be followed. After removal of the lid take care of components C7, C9 and IC2 heatsink. In normal operation these components can reach a temperature of 55 Deg C.

To install the MIC-IR-240PSU and MIC-IR-115PSU please do the following:-

1. Locate the mounting position of the MIC-PSU so that it cannot be interfered with either intentionally or accidentally, a lockable cabinet is recommended.
2. Securely fix the MIC-PSU using M4 stainless steel screws & washers; ensure the cable glands have sufficient room to allow for the cables to enter.
3. Feed all cabling through the appropriate sized gland holes.
4. Connect the composite cable to HD3 following the colour coding as shown in the Table B & printed on the PCB, connect all wires.
5. Connect the Brown and Grey wires for the IR lamps to HD6 as per Table J
6. Connect the Coaxial video cable to the CN1 header.
7. If alarms are to be used connect these to HD2 as per Table I above
8. Telemetry connections are provided by headers HD3, HD4 and HD5 which respectively enable crimp or screw terminations for connecting the MIC400 to the control room.
9. Connect the power to HD1 carefully observing the polarity and voltage as per Table A.



10. A washer drive is provided on this power supply, a mains rated relay is fitted and pre-wired to the mains input feed via an on board fuse FS4 (rated at 2 Amps Ceramic quick blow) connection to a third party washer pump system should be made via HD7 as per Table K.
11. Once connected the washer drive can be tested using the red SW1 which should activate the pump. This will allow for priming the plumbing. When pressed the LED, (LED3) next to the washer switch should illuminate. The LED will also illuminate in response to telemetry commands to switch the washer on. The Red LED on the washer PCB will illuminate when the Washer function is selected at the control room end. Note that the software in the camera prevents the washer from being run more than 10 seconds continuously. (This is to prevent the washer bottle from being inadvertently emptied. The red button on the washer drive card can be used to both test the washer operation and to prime the washer pump.
12. When wiring is complete, apply power & check the all six (6) LED's are lit. LED1 and LED2 when light show that 15v AC is available from the power supply (i.e. the supply fuses are intact. There is no indication of the operation of the Telemetry lines as this would increase the load on these lines reducing the number of cameras that can be driven by a single telemetry spur.
LED 3 illuminates when the washer drive relay is selected to on.
LED 4 monitors the internally generated +5v rail used to drive the alarm interface circuits around HD2. This +5v supply is not available externally.
LED 5 illuminates when the IR supply is selected to on by the camera telemetry.
LED 6 Pulses on/off when the MIC400 camera is correctly configured to operate with the IR power supply.
13. When satisfied the PSU is functioning correctly, re-attach the enclosure lid & screw down until tight.

MIC-IR-12PSU

The power supply operates from a 12v DC source typically between 10.5v and 15v DC, for example, a lead acid battery. The PSU provides power to a MIC400 camera at 18v DC nominally.

Current draw:

For the camera non-moving is 600mA. Worst-case current draw whilst moving is 1.5Amps
Max current draw with camera moving, wiper on and IR illuminators on is 3.8Amps.

Dimensions

Power supply enclosure: - 260mm (W) x 90mm (H) x 120 (D)

A weather resistant (IP66) box prefitted with four cable glands.

A second isolated power supply for driving the IR illuminators, the operation of this power supply is controlled by the camera itself via telemetry commands received from the control room. The power supply operates with dual illuminators. This drive is a constant current drive which automatically configures itself for IR lamp operation. There are no adjustable items within the power supply except for the three links discussed below.

Screw termination of all third party cables into and out of the box.

Correct video termination for the camera coaxial cable.

The power supply provides a circuit for operating a 12v driven washer drive pump and reservoir system.

The power supply also supports 4 off volt free alarm contact inputs, which can be made to activate presets within the camera but always notifies the control system of the status of these alarms.

Earthing, the power supply and all equipment connected to it is earthed to the -ve side of the battery supply permanently.



Power Supply layout and connections

The MIC-IR-12PSU power supply PCB has the following connections as shown on Figure E

- HD1 – Power Input connector (screw terminal)
- HD2 – Alarm Input header (screw terminal)
- HD3 - Composite cable header (Connections to camera head, screw terminal)
- HD4 - Telemetry header (Molex Connection)
- HD5 - Telemetry header (screw terminal)
- HD6 – IR Lamp header (screw terminal)
- HD7 – Washer drive power input header (screw terminal)

Table M – Fuse ratings for MIC-IR-12PSU

Fuse	Function	Type	Rating
FS2	Input fuse for main camera supply.	Glass	5A Quick Blow
FS4	IR Lamp supply fuse.	Glass	5A Quick blow.
FS5	Local +5v supply fuse	Glass	0.5A Quick Blow.
FS6	Washer supply protection fuse.	Glass	5A Quick Blow.

FIGURE E – MIC-IR-12PSU Schematic

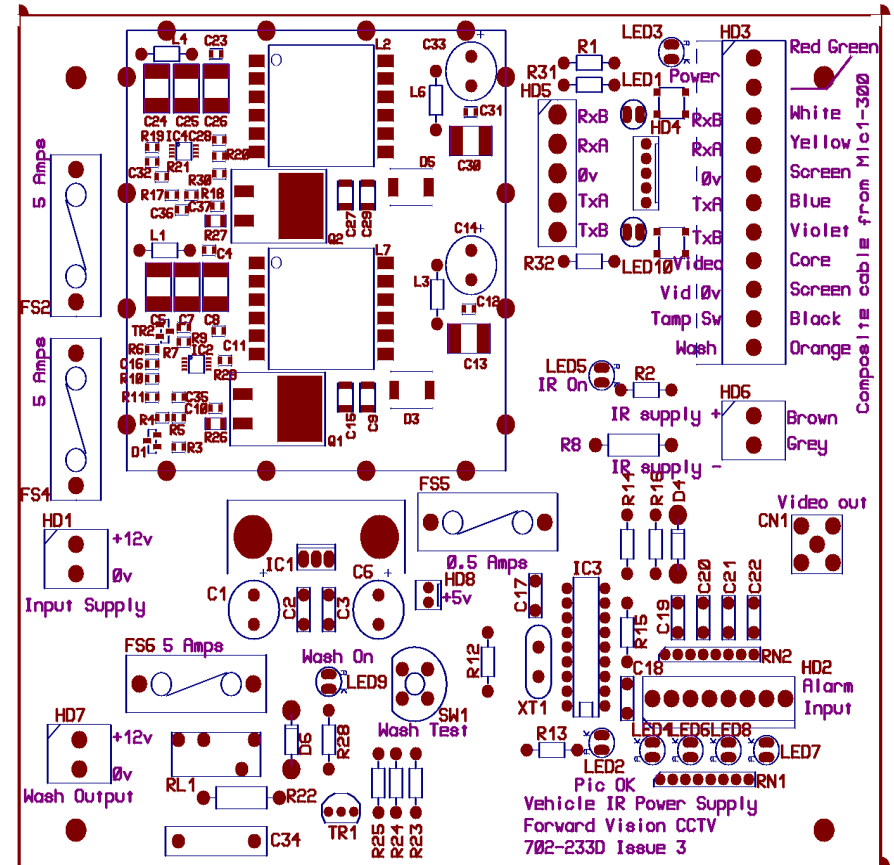

Note: there are no PCB link options on this PSU.



Installation Instructions



WARNING: Electrical Danger: Ensure all power is disconnected before opening or working upon any Power Supply Unit. Installation must be carried out by suitably qualified persons & all local safety regulations should be followed. After removal of the lid take care as components can reach a temperature of 55 Deg C.



CAUTION: It is extremely important to observe the correct polarity, failure to do so will result in the destruction of the DC-DC power supply.
CAUTION: This power supply was designed for negative earthed vehicles only it is not suitable for use with positive earth vehicles.

To install the MIC-IR-12PSU please do the following:-

1. Locate the mounting position of the MIC-PSU so that it cannot be interfered with either intentionally or accidentally, a lockable cabinet or secured vehicle location i.e. a lock box or mount rack is recommended.
2. Securely fix the MIC-PSU using M4 stainless steel screws & washers; ensure the cable glands have sufficient room to allow for the cables to enter.
3. Feed all cabling through the appropriate sized gland holes.
4. Connect the composite cable to HD3 following the colour coding as shown in the Table B & printed on the PCB, connect all wires.
5. Connect the Brown and Grey wires for the IR lamps to HD6 as per Table J
6. Connect the Coaxial video cable to the CN1 header.
7. If alarms are to be used connect these to HD2 as per Table I above.
8. Telemetry connections are provided by headers HD4 and HD5 which respectively enable crimp or screw terminations for connecting the MIC400 to the control equipment.
9. Connect the power to HD1 carefully observing the polarity and voltage as per Table A.
10. A washer drive is provided on this power supply, a mains rated relay is fitted and pre-wired to the mains input feed via an on board fuse FS4 (rated at 2 Amps Ceramic quick blow); connection to a third party washer pump system should be made via HD7 as per Table K.
11. Once connected the washer drive can be tested using the red SW1 which should activate the pump. When pressed the LED, (LED3) next to the washer switch should illuminate. The LED will also illuminate in response to telemetry commands to switch the washer on. The Red LED on the washer PCB will illuminate when the Washer function is selected at the control room end. Note that the software in the camera prevents the washer from being run more than 10 seconds continuously. (This is to prevent the washer bottle from being inadvertently emptied. The red button on the washer drive card can be used to both test the washer operation and to prime the washer pump.
12. When wiring is complete, apply power & check the all six (6) LED's are lit.
13. LED1 and LED2 when light show that 15v AC is available from the power supply (i.e. the supply fuses are intact. There is no indication of the operation of the Telemetry lines as this would increase the load on these lines reducing the number of cameras that can be driven by a single telemetry spur.
14. LED 3 illuminates when the washer drive relay is selected to on.
15. LED 4 monitors the internally generated +5v rail used to drive the alarm interface circuits around HD2. This +5v supply is not available externally.



16. LED 5 illuminates when the IR supply is selected to on by the camera telemetry.
17. LED 6 Pulses on/off when the MIC400 camera is correctly configured to operate with the IR power supply.
18. Please see the section on commissioning MIC400 Power Supplies for details on commissioning and setting up alarms.
19. When satisfied the PSU is functioning correctly, re-attach the enclosure lid & screw down until tight.

Commissioning the IR lamps

The following instructions apply to all MIC400IR cameras; please connect to a PC via RS422/485 telemetry and Universal Camset as shown on the next page, before applying power to the power supply check that all connections are correct.

Apply power to the unit and ensure that the 2 Red LEDs at the top of the PCB (under R1) and the +5v LED (LED4) are all on. This confirms that Fuses FS1, 2, 3, and 5 are intact.

Check that the MIC400 is generating a video picture.

Once connected set the camera current address in CamSet and check that the camera can be moved using the pan, tilt and stop buttons.

The IR lamps selection is enabled by entering the [Setups](#) tab and setting the [Multi Alarm](#) mode on and [Auto IR](#) on. The PSU board LED should start flashing (LED 6) called [PIC OK](#) to indicate correct operation.

CHAPTER 4 Configuring the MIC400 Camera

Connecting the MIC400 to the PC

The MIC can be connected to a PC's serial port via a RS232/RS422 adaptor unit; this will generally be assigned to Comm Port 1.

Suitable serial port adaptor units are the Greenwich RS232/RS422 adaptor unit (Farnell 778-758, RS No: 201-758), the KK systems K2-ADE RS232 to RS485/422 adaptor or the MIC-USB485CVTR (485 to USB Converter) for PC's without a serial port.

Connecting the Greenwich Adaptor

To connect the Greenwich serial adaptor to the PC you will also need a 9 pin D female to 25 pin D male RS232 compatible adaptor cable. A suitable cable is Farnell 960-573 or RS Part No: 202-644.

The adaptor should be set to DCE mode and the power supply connected.

Connections from the Greenwich adaptor to the MIC400 power supply are as follows:

Table N – Connecting the Greenwich Adaptor

Adaptor Connections	HD4
F 778-758.	Connection and wire colour.
DATA OUT 6-3+	RXB White
DATA OUT 5-4-	RXA Yellow
SCREEN	0v
DATA IN 4-5-	TXA Blue
DATA IN 3-6+	TXB Violet



The connections can be tested by selecting the DETECT button in Camset and checking to see if the window below this button displays the address and software version No of the camera being tested.

Should a problem be encountered then connect the MIC400 screen wire (0v) to the pc chassis with a separate piece of wire to ensure 0v continuity

Connecting the KK systems K2-ADE RS232 to RS485/422 Adaptor

This unit is self powered and can be plugged directly into the PC serial port. RS485 two wire mode.

Connections and Dip switches settings for 2-wire mode should be made as follows:-

Table O – K2-ADE Adaptor connections

Adaptor Connections	HD4
K2-ADE	Connection.
Pin 3	RXB White
Pin 9	RXA Yellow
Pin 5	0v
Not required	TXA Blue
Not required	TXB Violet

DIP Switch	Setting
Sw 1	OFF
Sw 2	OFF
Sw 3	OFF
Sw 4	ON
Sw 5	OFF
Sw 6	ON

With all the above set up, when Camset is running and the serial port selected, set the Camera Interface Controls to the following:-

Table P – Camera interface control settings

Camset Tabs	2 Wire RS485	4 Wire RS422
Comms 1	Selected	Selected
Interface	2 Wire	4 Wire
RTS	Off	On
Baud	9600	9600

If a notebook PC is used, which sometimes lacks a serial port, then a RS485 to USB converter such as the MIC-USB485CVTR can be used instead, this would typically be mapped to Comms port 3 or 4.



Connecting the MIC-USB485CVTR, USB to RS485 Converter

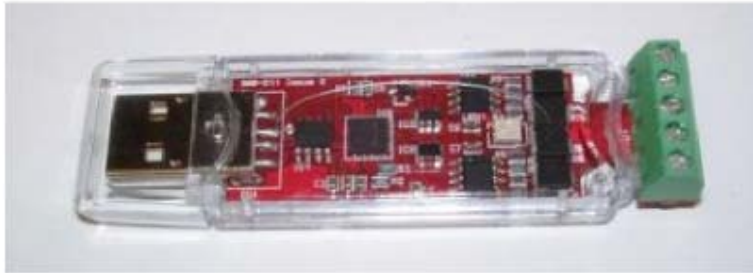

The MIC-USB485CVTR is a USB to RS485 signal converter that allows PCs without a serial port to connect directly to the MIC400 series camera via the telemetry connection (HD4) in the power supply, the MIC-USB485CVTR can also be used to connect a PC to any other RS485 device.

The MIC-USB485CVTR has been designed to work with all functions in Universal Camset and to be backwards compatible with legacy version of Camset although full compatibility is not guaranteed.

The MIC-USB485CVTR should be connected to the telemetry header (HD4) of the MIC400 power supply with Standard Twisted Pair cable such as Belden 8760.

The table overleaf shows how the screw terminal connections on the MIC-USB485CVTR connect to the MIC power supply depending upon the protocol and selected communication mode you may only need a 2 wire configuration.

Table Q – MIC-USB485CVTR Connection Table and Diagram

Converter Output	MIC Power Supply Telemetry Header (HD4 or HD5)	Communication Mode
RxB / Rx -	TxB	Full Duplex (4-wire only)
RxA / Rx +	TxA	
GND / 0V	GND	Shield (always)
TxA / Tx -	RxA	Simplex Half Duplex (2-wire) Full Duplex (4-wire)
TxB / Tx +	RxB	



CAUTION: Should be taken to avoid earth loops when connecting 0v from the converter to GND terminal in the MIC power supply



MIC-USB485CVTR and Universal Camset Software Installation

Universal Camset comes with WHQL certified drivers for the MIC-USB485CVTR that must be installed prior to connecting the converter to the PC.

To install the drivers please do the following:-

1. Locate the [USB DRIVERS.EXE](#) in the Universal Camset Folder, double click to begin and follow the on screen instructions to install; these are the required drivers for using the MIC-USB485CTR.
2. Locate the [CAMSET INSTALLER.MSI](#) and then double click to begin, follow the on screen instructions to install.
3. Once installed a Universal Camset Icon will appear on your PC Desktop.
4. When opened the Universal Camset will display the Standard Controls Tab as shown overleaf.

Providing the USB drivers have been installed successfully, you can then plug the MIC-USB485CVTR into a PC via the USB port. If your converter is being plugged in for the first time your system should recognise the device and inform you that the hardware has been installed successfully.

The MIC-USB485CVTR should appear in the Comm Port selection list as USB and as a virtual Comm Port, e.g "comm2" (for legacy support). Universal Camset has been optimised to work with this converter in USB mode; therefore users should select "USB" for maximum functionality and reliability.

The MIC-USB485CVTR has a status LED indicating its current state, by sending a manual command e.g. Left or Right, you should see the LED flash. Transmitted data from the converter is indicated by a **red** flashing LED flash and upon receiving data a **green** LED will flash.

Commissioning the MIC400 through Universal Camset

Universal Camset is a Windows PC based configuration software from BOSCH Group; it is issued free on the CD that comes with each MIC camera. Universal Camset supersedes all previous versions of Camsets used.

Standard Controls

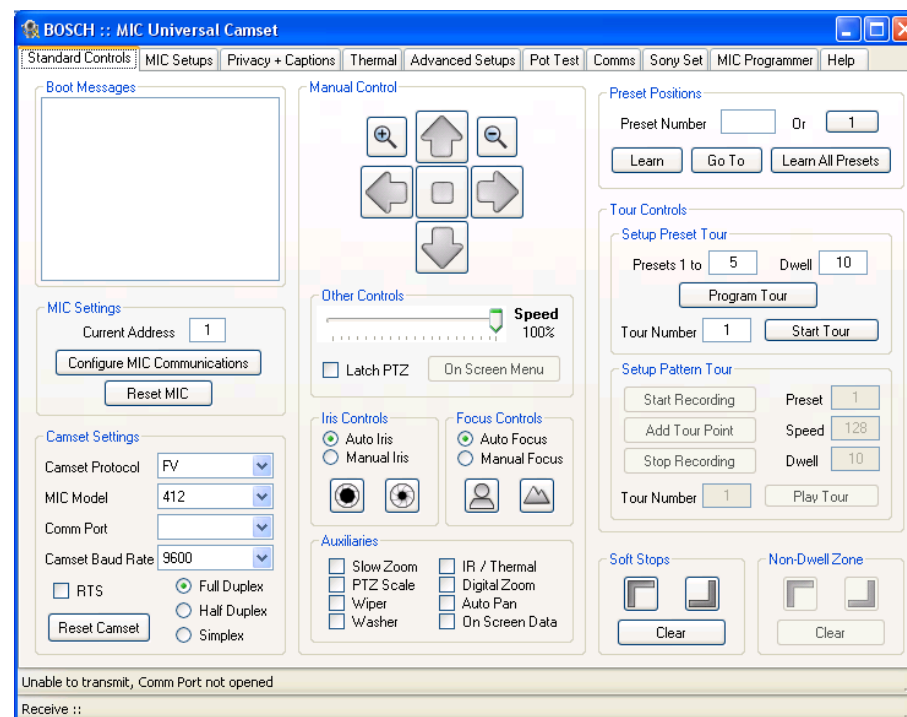

Universal Camset opens on the [Standard Controls](#) tab as shown above; the highlighted area contains the Boot messaging, MIC settings and Camset Settings controls.



Boot Messages

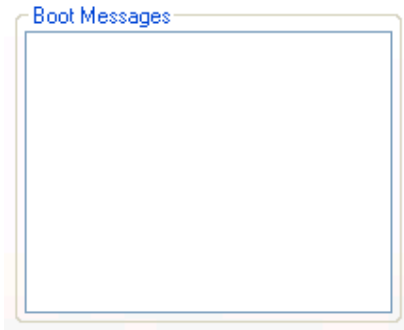

The large square text box in this area will display boot messages coming from the MIC. One of the first lines contains the MIC address which is decoded and entered into the [Address](#) line. The rest of the lines indicate the MIC model number, control card serial number, MIC Software etc.

At the same time, a boot message is displayed on the video indicating similar information, which may be helpful if return comms should fail or be incorrectly connected.

MIC Settings

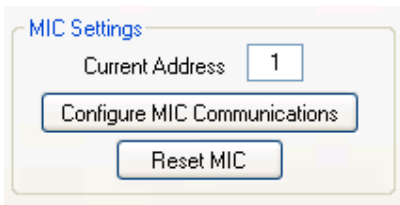

Current Address

This box indicates the address to which commands are sent from Camset. This therefore needs to match the address of the MIC that needs to be controlled.

When the MIC is booted the first line of the messages it sends is the address, which is read and put into this box automatically.

Configure MIC Communications

This button opens up a new window which provides the options to reconfigure the MIC communications settings. These options will depend on the MIC model connected.



In order for any of these modifications to work, Camset must have full communications with the MIC. Ensure this by performing a simple manual control test (Up, Down, etc). To store the new settings press [Apply](#) once the modifications have been made or alternatively press [Cancel](#) to discard any changes.

New Address

This input box defines the new address the MIC should change to once [Apply](#) has been clicked. The value will also be copied over into [Current Address](#) on the main form to provide continual control.

New Protocol

The drop down list here provides a full list of the protocols available in Camset. Control depends upon selecting the correct protocol in the drop down list to match the protocol that is loaded onto the MIC400; if the incorrect protocol is selected in Camset the MIC may not respond. To regain control should this happen, reset the Camset Protocol back to what the MIC originally was.

New Baud Rate

This drop down list will provide the valid baud rates for the chosen protocol. The baud rate options reflect the protocol as set on the main form for Camset itself. In FV protocol the option is a toggle which simply switches the MIC between 4800 and 9600. If control is not present after the window is closed, try changing the Camset Baud Rate.

Reset MIC

This sends out a command to reboot the software. This is not a hardware reboot; the only way to do that is to remove the power supply to the MIC.

Camset Settings

The [Camset Settings](#) section as shown above control the Protocol, MIC model, Baud Rate and Comm Port used; select the appropriate parameters for your MIC400 from the dropdown menus.

Some functions in Universal Camset may not be supported by particular protocols; any incompatible functions will be greyed out if it is not supported in a given protocol.

The communication settings will be set to the default for the chosen protocol, indicating this on the Camset Baud Rate drop down list.

MIC Model

This provides a list of all the available MIC Models. This should be set to the type of camera being controlled as Camset is then set up accordingly to provide more or less options dependant upon the combination of this setting with the Camset Protocol above.

Comm Port

This provides a list of the available Comm Ports detected by the software on the PC. If a comm port is in use when it is selected the user will be prompted with an error, and should either select another port or close the application currently using it. If the MIC-USB485CTR, USB to RS485 convertor is being used, when plugged in this will show on the Comm Port drop down menu as **USB**, simply select to use. The final option is close which will close any open communications port meaning that other applications can then use the port for other purposes.

Camset Baud Rate

This displays the current Baud Rate at which outgoing messages are sent, and the other options available for the given protocol above. Changing this without first changing the MIC baud rate will cause a loss of communications.

RTS

This defines the state of the RTS line on the serial port which can be used power in line RS232 to 485 adapters.

Comms Mode

There are 3 available options for comms modes:

Full Duplex: Full 2 way 4 wire communications connection. Messages are transmitted and received on separate comms pairs.

Half Duplex: 2 way, 2 wire communications connection. Messages are transmitted and received on the same pair of wires. The 485 drivers deal with the switching of the line directions automatically.

Simplex: 1 way 2 wire communications connection. Messages are only transmitted to the camera. This will work for most manual controls, but anything that requires a response, such as Pot Test, Exact Positioning, Programming etc will fail.

Reset Camset

This re-initialises all of the controls for the software to the state it would be on boot.

Manual Control

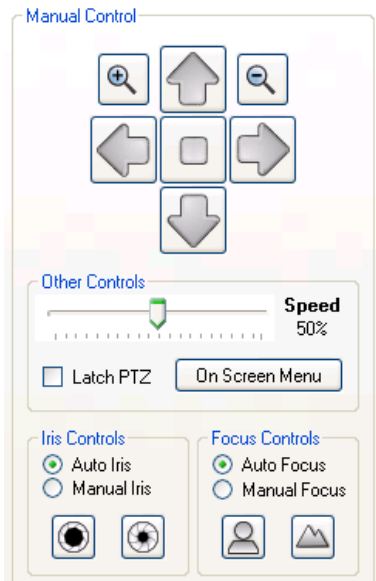

Pan, Tilt and Zoom Controls

The **Up**, **Down**, **Left** and **Right** buttons send commands to the MIC to move in the selected direction at the speed indicated by the **Speed Slider**.



Zoom In  and **Zoom Out**  control the zoom position of the camera lens at a fixed rate.

Latch PTZ: This tickbox will Latch the PTZ controls for continuous tilt or rotation as required.

Iris Controls



Auto Iris lets the MIC automatically adjust to changing light levels, where **Manual**

Iris gives the user control with **Open**  and **Close**  buttons.

Focus Controls



Auto Focus lets the MIC automatically focus on a changing scene, **Manual Focus**

gives the user control with **Near**  and **Far**  buttons.

Auxiliaries



Slow Zoom: Reduces the speed at which the MIC zooms.

PTZ Scale: Scales the MIC speed dependant on zoom position.

Wiper: Turns on or off the MIC wiper if fitted.

Washer: Activates the washer relay on the MIC-WKT card or the MIC-ALM card if fitted in the PSU. This also moves the MIC to the stored [WashWipe](#) position and turns on the wiper. Once de-activated the MIC will return to its original position and turn off the wiper.

IR / Thermal: Dependant on the MIC this will do one of 3 things, for a Non-IR Standard MIC the IR cut filter will come in and the image will go black and white. For a twin IR MIC, the cut filter will come in and the lamps will turn on. Note: If the lamps do not turn on, ensure the power supply is an IR version and that [Auto Alarm](#) and [Multi Alarms](#) in the [MIC Setup](#) tab are both turned on.

For a MIC412, the video output will switch from the Sony module to the thermal module; the controls on the [Thermal](#) tab will also now function.

Digital Zoom: This will enable the MIC to continue into the digital zoom once the optical limit has been reached. This also needs to have [Digital Zoom Enabled](#) under the [MIC Setup](#) tab.

Auto Pan: This will start the MIC panning between left and right defined limits.

On Screen Data: This activates the Sony modules on screen icons.

Preset Positions



Preset positions are locations stored by the MIC in Pan, Tilt and Zoom, Focus etc, which can be either called back manually, or returned to as part of a preset position tour.

To learn a position move the MIC to the desired location and then either enter in the preset number in the box available or press the [Preset Number](#) button until it displays the desired value. Then press the [Learn](#) button to store. Once stored the value in the input box will be cleared.

Returning to a position uses the same number entry method and then press the [Go To](#) instead.

The [Learn All Presets](#) button will set every preset position available for the given protocol to the current position. This may take a few seconds.

Tour Controls



Tours provide a way of making a MIC continually move to points of interest within its visible range. There are 2 different methods to enable this; [Preset Tours](#) recalls preset positions in the set order waiting at each for a desired dwell time while [Pattern Tours](#) mimic the operator's movements whilst recording so it can follow a defined path.

Access to these methods is entirely protocol specific, meaning if it is shaded out, the feature is not supported. In some cases there are up to 6 tours available.

Preset Tours

To save a preset tour, simply enter the end preset number into the input box and a corresponding dwell time and press [Program Tour](#). This initiates a simple tour with each steps preset position being fixed and the dwell time constant across the tour, stored to the Tour Number. More comprehensive program methods are normally available through the control system.

The [Tour Number](#) selects the tour to which you save and also play from. The [Start Tour](#) button initiates the current programmed sequence for the given Tour Number.

Pattern Tours

Depending on the protocol, the controls for these vary. Some fully implement the recording functionality and in these cases the [Start Recording](#) and [Stop Recording](#) buttons are used, with user manual control in between. This is again stored to the [Tour Number](#) as set.

Other protocols use an add point method, where [Start Recording](#) and [Stop Recording](#) are used in the same way, but instead of manual control in the middle [Add Tour Point](#) is used to insert a preset position with the options specified [Preset](#), [Dwell](#) and [Speed](#).

Soft Stops and Non Dwell Zones

This feature offers a method of restricting the MIC's movements to a certain area. A "box" is defined using the [Top Left](#) and [Bottom Right](#) buttons which provides the area within which the MIC is allowed to move. To clear the area set both corners to the same location.

Non-Dwell Zone

This provides the opposite of Soft Stops, in that an area can be defined within which the MIC cannot stop. The area is defined and cleared in the same way using the [Top Left](#) and [Bottom Right](#) buttons. Once the MIC enters the area it passes straight through to the opposite edge.

Clear

This button clears both the [Soft Stops](#) and the [Non-Dwell Zone](#), which is required after a MIC has its protocol re-flashed (see Programming section).



MIC Setups

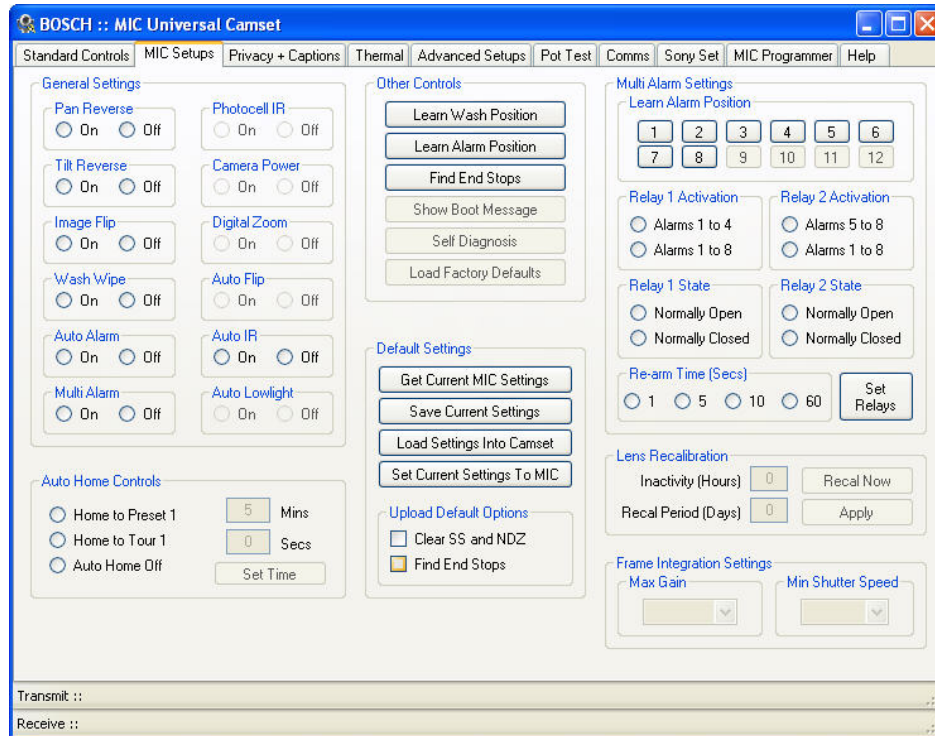

The **MIC Setups** tab contains the basic camera controls such as General Settings, Multi alarms (if MIC-ALM card is fitted), Relays, AutoHome options and the Default Settings.

General Settings

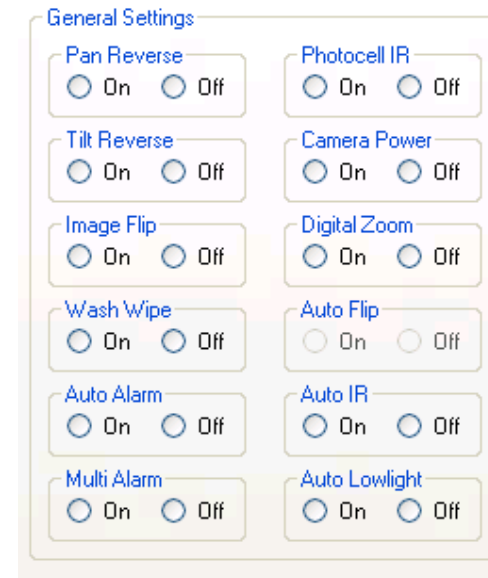

Pan Reverse

This will invert the pan rotation of the MIC compared to the commands from the controller. This would be used if a MIC was inverted to regain logical control.

Tilt Reverse

This will invert the tilt rotation of the MIC compared to the commands from the controller.

Image Flip

This manually inverts the image from the camera module, which may be used on an inverted camera where the head cannot be rotated through 180 degrees. Inverting the image would normally also require some modification of the control directions.

Wash Wipe

If Wash Wipe is On then, when the Wash auxiliary is set the MIC will return to a preset Wash Position activate the washer relay in the PSU and turn on the wiper. When the auxiliary is turned off again, the MIC will return to its prior position and turn the wiper off. If Wash Wipe is Off then when the aux is activated the MIC will simply close the washer relay and remain in its current position.

Auto Alarm

This is used for both single and multi alarm functionality. With Auto Alarm on and Multi Alarm off, the MIC will monitor the tamper switch line, moving to the programmable Alarm Position when the connection is grounded. If Auto Alarm is turned off the MIC will ignore any change in status of the tamper line.

Multi Alarm

With this the user can setup a separate position for each of the 8 alarm inputs. Any given alarm input will trigger the MIC to move to the position with which it is associated. To get this functionality working both Auto Alarm and Multi Alarm should be turned on.

Photocell IR

This mode enables the user to attach an external photocell to the power supply to control the IR lamps. The device is connected to alarm input 4, meaning that when the light levels drop sufficiently alarm 4 is triggered, and instead of moving the MIC detects this as an activation signal for the lamps. When the light levels pick up again, the alarm will deactivate and the lamps will be turned off. This mode can enable the user to hide the sensor away from any large external lighting which may cause the camera to flick in and out of IR mode under Auto conditions.

Camera Power

This can be used to turn the camera module inside the MIC off as required.

Digital Zoom

This is an override for the Digital Zoom Auxiliary, meaning that if On this will allow digital zoom to be controlled by the aux state, but if off, will never allow digital zoom no matter what the state of the aux.

Auto Flip

With this enabled the MIC will pan through 180 degrees as it reaches the vertical position so the user can then tilt down the other side meaning the MIC video is never inverted. Once the rotation is complete the controls are reversed until a stop command is received, at which point they are returned to normal.

Auto IR

In this mode the camera module is monitored for its current IR state, as soon as the light drops sufficiently, the module will automatically put the cut filter in place and switch to black and white, at which point the MIC will turn on the IR lamps.

Auto Lowlight

If this is turned on, the MIC will decrease its shutter speed as the light levels drop, rather than increasing the gain. Motion blur on the video can occur if the frame rate drops sufficiently low, which may not be ideal for a camera which is continually moving. However if motionless, the images will not have the grain associated with lowlight conditions. The gain at which a change is made and the lowest frame rate can be controlled under the Frame Integration section.

Auto Home Controls



After a programmable time with no manual control the MIC can be configured to either, move to the home position (Preset 1) or start tour / pattern 1. With **Auto Home** turned off the MIC will simply remain stationary until the next user input. The amount of time before this takes place can be set using the input boxes and the **Set Time** button.

Other controls



Learn Wash Position

This is the position that the MIC will return to when the Washer Auxiliary is activated and [Wash Wipe](#) is turned on. This should point towards the washer jet nozzle.

Learn Alarm Position

This is the alarm position for the tamper switch. The MIC will return to this position if [Auto Alarm](#) is turned on, [Multi Alarm](#) is turned off and the tamper line in the PSU is pulled to ground.

Find End Stops

This will get the MIC to rotate in the tilt axis first down then up to its mechanical limit stops. It will then store a "soft" limit a few units back from these for normal use. During this process manual control is not available.

Show Boot Message

This will display the boot message that appears on the video for a few seconds, this may be helpful to determine the current software of the MIC, without having to do a full reboot.

Self Diagnosis

This function is for future products and does not work with the MIC400 or MIC412.

Default Settings

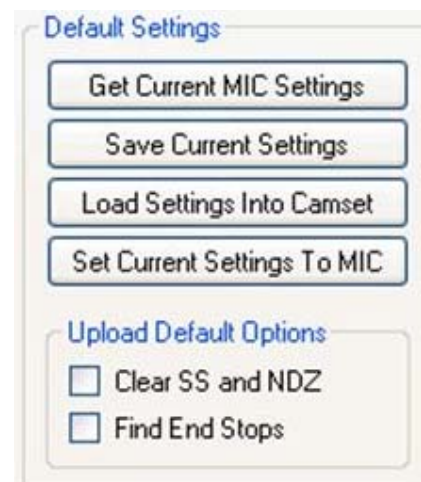

The Default Settings tab reads and sets settings from the following sections:

- Manual Control Auxiliaries
- General Settings
- Auto Home Controls
- Multi Alarm Settings
- Lens Recalibration
- Frame Integration Settings
- All Thermal controls

All other settings will not be saved, loaded, downloaded or set through the following controls.

Get Current MIC Settings

This downloads the current status of each of the settings from the MIC and loads it into the text boxes and radio buttons on Camset. This provides an easy way of viewing the current setup of each MIC and also a way of copying the settings from one into the next.

Save Current MIC Settings

This option will first prompt for a file location and then store the current state of all the options outlined above to an XML file which can then be loaded at a later date back into Camset as a standard for a specific site.

Load Settings into Camset

This will prompt to open an XML file as saved above. Only valid Camset Default XML files will work.

Set Current Settings to MIC

This will go through each of the settings above except for thermal, and send out the commands to the MIC to set it up as Camset displays. This may take a few seconds as there are several commands involved in this process.

Upload Default Options

At the end of this there are 2 extra options for defaults, [Clear SS and NDZ](#) will clear any saved Soft Stops and Non-Dwell Zones and then [Find End Stops](#). These options may be used to completely set up a MIC after it has been reprogrammed to a new protocol.

Multi Alarm Settings



Learn Alarm Positions

Simply point the MIC400 at the position you would like it to cover when each numbered alarm is triggered and press [Learn Alarm Position](#) to set this.



Relay State, Activation and Re-arm

This function is available only to MIC-400's with the MIC-ALM card fitted or the MIC400IR Power Supply which has Four (4) Alarm Inputs built in.

The MIC-ALM multi alarm card provides 2 output relays which can be configured to close or open on given alarm inputs. Relay 1 can be activated from either alarm inputs 1 to 4 or 1 to 8 and relay 2 with alarm inputs 5 to 8 or 1 to 8.

The re-arm time is a time in seconds before the MIC returns to its current position and returns the relay to its prior state. The options for this are 1, 5, 10 or 60 seconds. To send the settings to the MIC select the desired options and then press **Set Relays**.

Lens Recalibration and Frame Integration

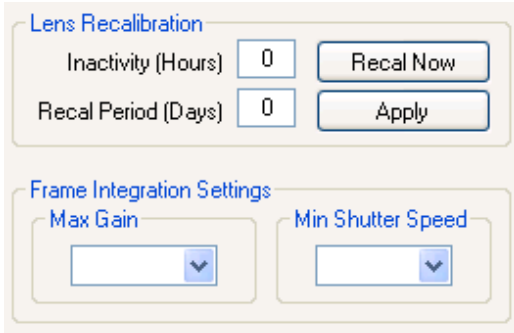

This section defines when and how often the Sony Optical Camera block should perform a recalibration process. The first field Inactivity defines how long in hours it should be after the last manual control command before the first recalibration should take place, and the second is a time in days between each successive recalibration from then on.

To set these enter the appropriate values in the text boxes provided and press **Apply**. Alternatively the **Recall Now** button will perform a manual recalibration.

Frame Integration Settings

This section defines the **Max Gain** and **Min Shutter Speed** parameters used by the MIC when in Auto Lowlight mode. The drop down lists provides the actual settings available in dB for gain and FPS for shutter speed. The **On Screen Data** auxiliary command will indicate the current frame rate if required. The values are set by simply selecting the desired option from the drop down lists.

Privacy and Captions

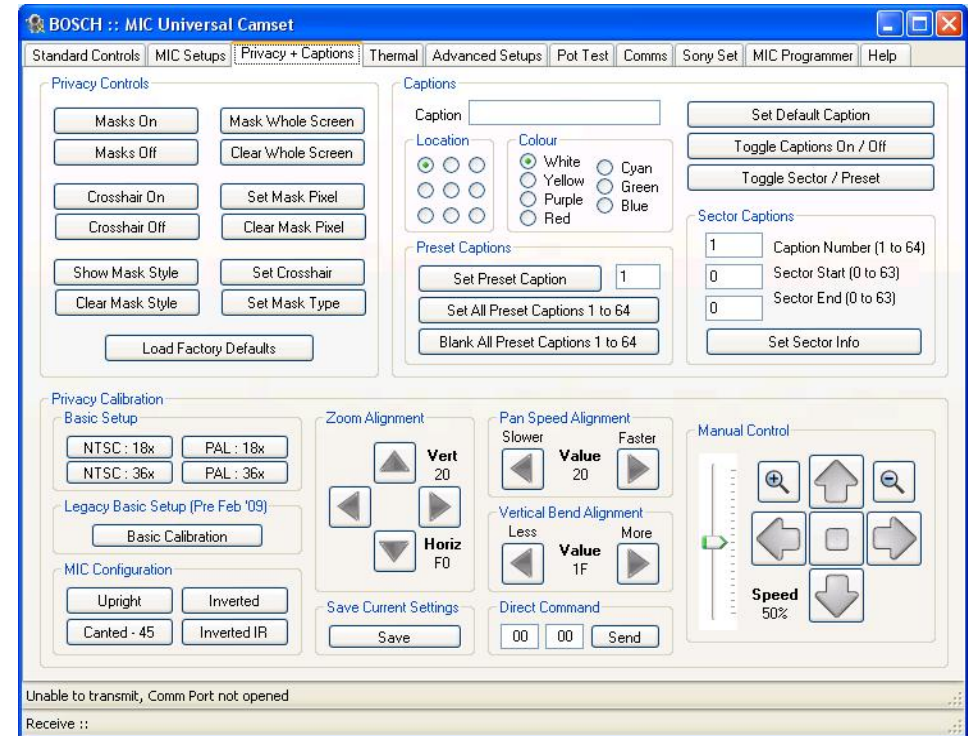

The **Privacy and Captions** tab allows the user to define and set the privacy mask function if the optional privacy card is fitted; this is not applicable to the MIC400 as the privacy card cannot be used with the thermal imager.

Privacy Controls

Masks On / Off

This is an override setting to turn masks completely **On** or **Off**. This will not clear each individual masks settings, so when **Off** is sent they will disappear and then re-appear with **On**, in the same positions.

Crosshair On / Off

This setting makes a crosshair appear on the video display centered on the middle of the video. This can then be used to set individual mask pixels with the appropriate command from below.

Show / Clear Mask Style

This setting provides a preview of the current mask style. This will only work if the Crosshair is turned **On**. It will show a small privacy block to the right of the crosshair center. If nothing appears, the mask may be clear, so use the **Set Mask Style** to change to a visible setting. Once the required style has been selected; press **Clear Mask Style** and **Crosshair Off**, to return to the normal state.

Mask / Clear Whole Screen

These functions will add or remove a privacy mask the size of the entire current view. Moving the MIC in Pan or Tilt should then indicate the zone clearly. This would most commonly be used in conjunction with zoom where a window can be made full frame and then the whole thing masked as apposed to the method below which may take significantly longer.

Mask / Clear Pixel

This is a more accurate way of creating privacy masks one pixel at a time. The Pixel is created at the center of the image, or where the crosshair points if it is visible.

Set Crosshair

This will create a pixel sized mask as with the function above, and will also bring up the crosshair. Press again to remove the crosshair or use Crosshair Off.

Set Mask Type

If Crosshair and Mask Style are both turned On this function can be used to step through each of the available mask types one at a time. This will not update all the masks to the same type, only the ones that are created subsequent to the change.

Load Factory Defaults

Clears the current Privacy masks and resets the privacy card to the factory defaults.

MIC Configuration

These options define the MIC's orientation, which defines how the masks track. for Inverted MICs, the head would normally be rolled around through 180 degrees, with Pan Reverse On to regain sensible control. However, with inverted IR MICs, the head cannot be rotated around due to the IR Lamp arms, and therefore the video must be inverted, and both controls reversed.

Basic Calibration

This sends a set of default commands to the MIC to initialize the privacy for an upright MIC. This will not be perfect as each board needs fine individual calibration but provides a good starting point.

Zoom Alignment

The zoom alignment buttons provide accurate calibration of the mask tracking. This would normally be carried out by using a vertical line of mask on along a known straight edge. If this line then moves as the MIC pans and tilts, it can be corrected using the appropriate arrow. The labels indicate the current value in both the Vertical and Horizontal planes, which will be incremented or decremented dependant upon the direction pressed.

Direct Command

All privacy commands consist of 2 Hex bytes, a command byte and a data byte. These perform all of the privacy functions available. To enter commands, enter the 2 bytes in Hex, into the boxes provided and press **Send Command**. Entering random commands here may result in very odd results so please do not use unless under specific instruction.

Save Current Settings

Once any calibration changes are made, this button should be pressed to save the new values permanently.



Privacy Calibration



CAUTION: The Privacy Calibration settings should be configured at manufacture and should therefore not need to be changed on site. Any changes to these settings may be difficult to correct, so please do not attempt to change anything unless under instruction from Bosch.

The [Privacy Calibration](#) section deals with the calibration settings of the privacy masking. I.e. how the masks track as the MIC is moved in Pan, Tilt or Zoom.

MIC Configuration

These options define the MIC's orientation, which defines how the masks track. for Inverted MICs, the head would normally be rolled around through 180 degrees, with [Pan Reverse On](#) to regain sensible control. However, with inverted IR MICs, the head cannot be rotated around due to the IR Lamp arms and therefore the video must be inverted and both controls reversed.

Basic Calibration

This sends a set of default commands to the MIC to initialise the privacy for an upright MIC. This will not be perfect as each board needs fine individual calibration but provides a good starting point.

Zoom Alignment

The zoom alignment buttons provide accurate calibration of the mask tracking. This would normally be carried out by using a vertical line of mask on along a known straight edge. If this line then moves as the MIC pans and tilts, it can be corrected using the appropriate arrow. The labels indicate the current value in both the Vertical and Horizontal planes, which will be incremented or decremented dependant upon the direction pressed.

Direct Command

All privacy commands consist of 2 Hex bytes, a command byte and a data byte. These perform all of the privacy functions available. To enter a command, enter the 2 bytes, in Hex, into the boxes provided and press [Send Command](#). Entering random commands here may result in very odd results so please do not use unless under specific instruction.

Save Current Settings

Once any calibration changes are made, this button should be pressed to save the new values permanently.

Captions

The [Captions](#) tab allows the user to set up captions, Sector or Preset Captions; Screen Location and Caption Colour are all user definable.

The MIC has 3 different caption options available. On the MIC 400 model range only one line of text is available and therefore a Preset Caption will overwrite a Default Caption.

The [Default Caption](#) can be treated as the name of the camera. It will appear on the video whenever it can, i.e. when no Preset or Sector captions are selected.

Preset Captions can be used to display a different title for each of the preset positions available. This will be loaded once the MIC has reached the position. As an alternative, the same 64 captions can be used, not for preset positions but for rotational sectors. The MIC's pan is split into 64 segments and a different caption can be assigned to each or to a group. Using this option can result in an occasional slight control lag.



Whatever caption is being set the writing must be entered into the [Caption Text Box](#). The caption will be displayed in block capitals and only certain extra characters are recognised. Unknown characters will be displayed as "?".

Location and Colour

These options define where on the video and in what colour the caption will be.

Set Default Caption

This programs the current caption (if valid), position and colour settings to the default caption. If captions are turned on this should appear immediately on the video.

Toggle Captions On / Off

This setting is a global On / Off setting for captions. If Off then no captions will be displayed, Default, Preset or Sector.

Toggle Sector / Preset

This toggles between the 2 caption modes of Preset or Sector. These options are mutually exclusive.

Preset Captions

This section provides 3 options, to either set one preset caption to the preset number specified in the input box. Set all 64 presets to the same caption, or clear all 64 preset captions to nothing.

Sector Captions

This section allows the definition of the sectors and what caption to use for each. First the Caption Number is entered which corresponds to a preset caption, then the start and end of the group in terms of an individual sector. Press [Set Sector Info](#) to store the data.

Thermal

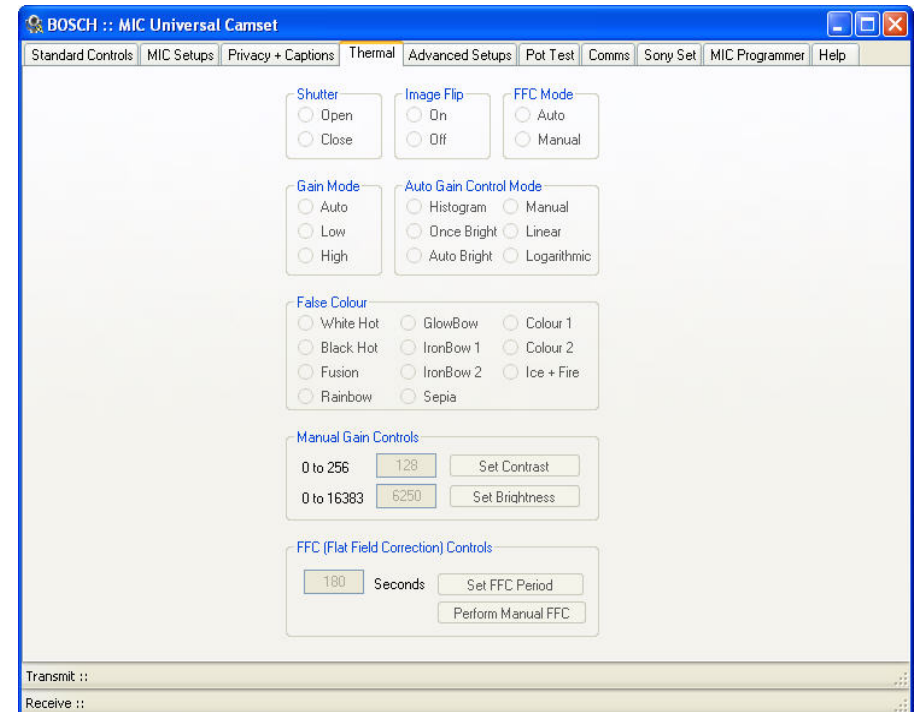

The [Thermal](#) tab controls the function of the FLIR thermal imager in the MIC412 only; this screen has no function with a MIC400 Camera.

Advanced Settings

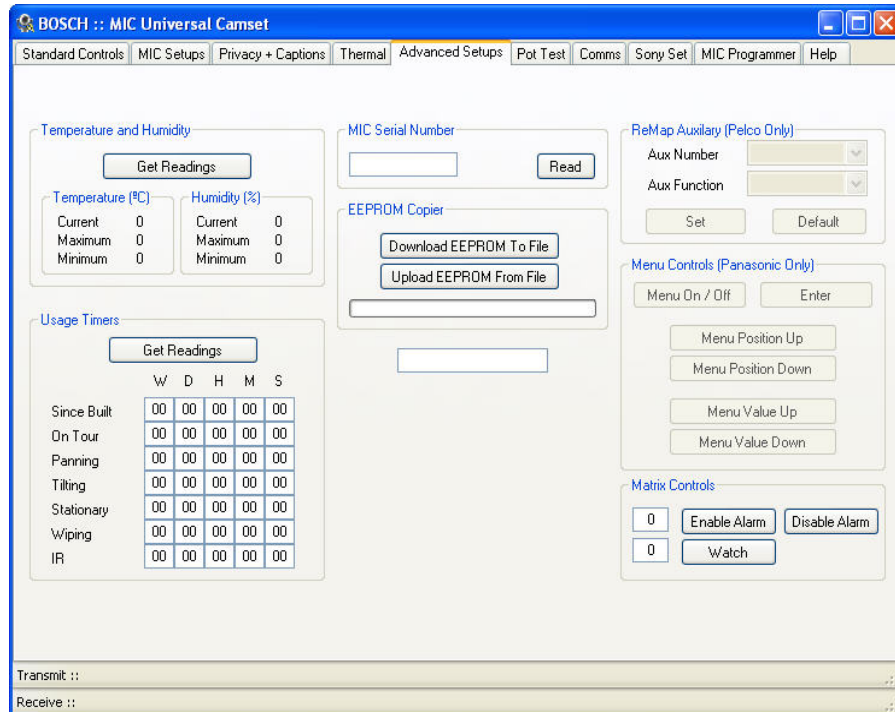

The [Advanced Settings](#) tab offers engineering and special auxiliary control modes for Pelco and Panasonic protocols (see Help file for details).

The MIC stores various statistics about itself, including temperature and humidity, and various timers for different parameters, which may be of interest to the end user, but are mainly implemented as an engineering tool.

Temperature and Humidity

This will only work if the MIC400 has the appropriate control card with the temperature and humidity sensor attached. [Current](#), [Max](#) and [Min](#) are displayed for

both in degrees and a percentage respectively. If the MIC reaches 70% humidity inside the head a small "H" is displayed in the top left corner indicating a Humidity problem. If this appears, make contact with Bosch Security Systems.

Timers

The timers monitor most of the common functionalities of a MIC: Panning, Tilting, On Tour, Since Built, Stationary, Wiping and IR Lamp shown in Weeks, Days, Hours, Minutes and Seconds.

Clear All Statistics

This function will set Max and Min for temperature and humidity to the current reading, and will clear all of the timers to "0". This feature should only be used when a MIC is first built or repaired, and therefore is locked out with the Advanced Controls Password.

MIC Serial Number

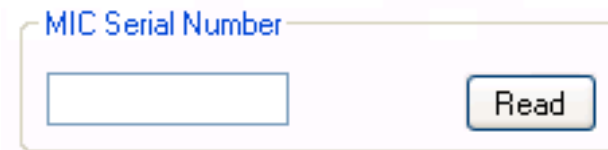

This feature is used to set or read the actual MIC Serial Number. This may be required to reprogram the MIC through the telemetry. The Set function is locked out with the Advanced Password as this should only be performed at the manufacturing stage, however read is available to use as required.

EEPROM Copier

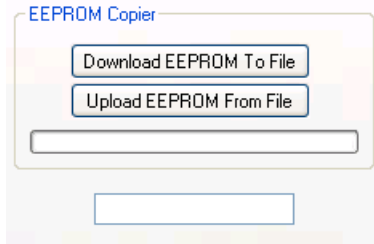

This feature can be used to download the complete EEPROM block from the MIC to a file and then upload it to another. This will port across every single setting stored in the MIC, thus making a mirror copy when loaded into the next. Everything except for the privacy calibration will be transferred as this is stored separately on the privacy card itself. Before using this feature ensure you are aware of the consequences, in that all preset positions will be changed to the ones stored in the file, same with the Sonyset table and finally the MIC address will also be copied.

Once uploaded, Camset will prompt to reboot the MIC which will then load the new settings into the MIC.

If any errors occur in the download or upload process then do not attempt to upload a half complete file, retry the process until it works fine.

Download EEPROM To File

This will prompt for a file location of type ".epm". If valid then the process will begin with the current status indicated on the progress bar. The file stores each data byte and its address in memory. These files should not be edited under any circumstances.

Upload EEPROM From File

This will prompt for a ".epm" file to open, again if valid the process will begin and the progress bar will show the current progress.

Remap Auxiliary (Pelco Only)

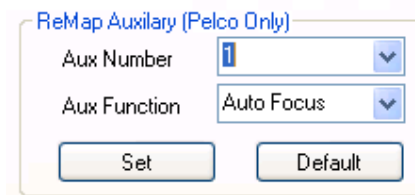

This section provides the option, for MIC400s with Pelco protocol only, to modify what aux the MIC actions for a given aux number input.

Pelco has 8 aux commands available and the MIC functions that can be mapped to them are as follow:

- Auto Focus
- Digital Zoom
- Auto Exposure
- IR
- Wiper
- Washer
- OSD
- Backlight

To modify an aux mapping, simply select the desired function and aux number from the list boxes and press Set. The default button will assign the functions in the order as above to aux's 1 through 8.

Menu Controls (Panasonic Only)

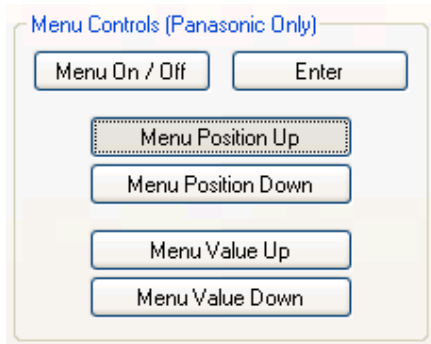

Matrix Controls

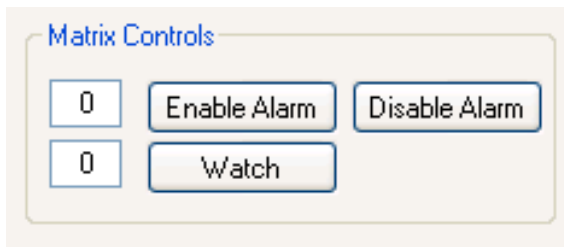

The options here provide controls for a Forward Vision Matrix. The **Enable** and **Disable Alarm** buttons will take the number provided in the upper input box, and perform the specified function on that alarm input.

The **Watch** button can be used to change the input channel on a Matrix (1 to 16) to the value specified in the lower input box.

POT Test

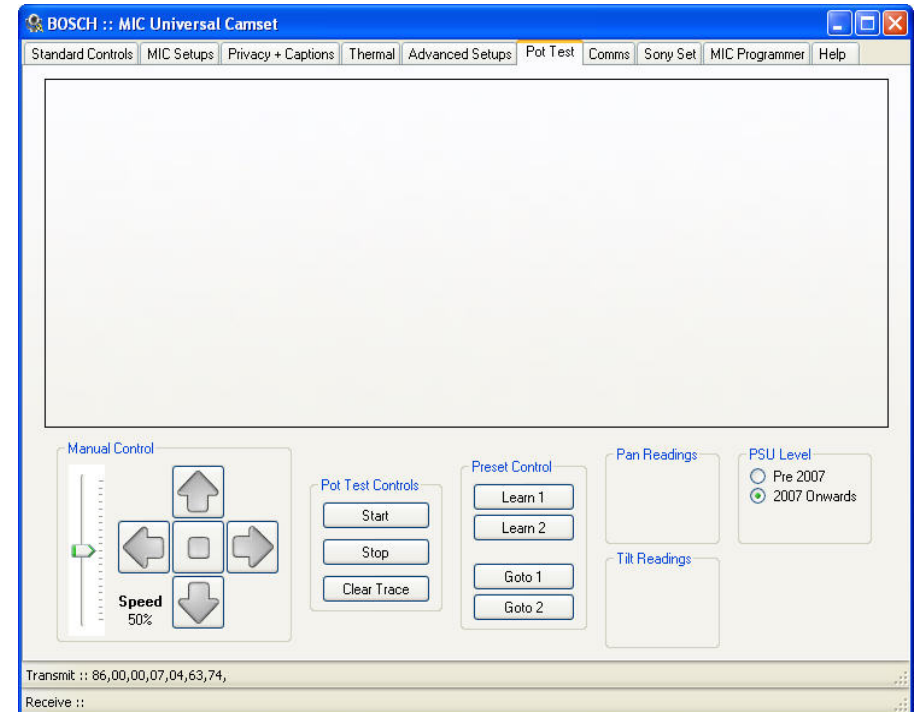

The **POT Test** tab is used as an engineering tool to determine the MIC's position, Motor PWM, Motor Speed in both Pan and Tilt, and the PSU level inside the MIC.

All the results are plotted onto a continually updating graph on the page and the current results shown in numeric values below. This process requires a reliable 2 way communications link with the MIC.

Pot Test Controls

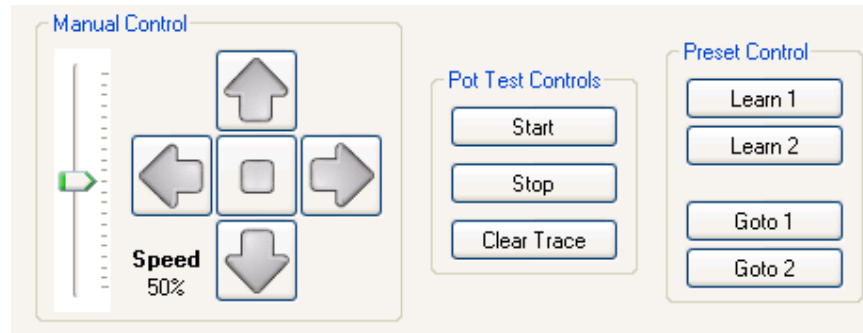

Start

This initiates the Pot Test process. Continual commands will be sent requesting the MICs current data, the responses will be decoded and data printed and plotted on the display.

Stop

This stops the process running. Pot Test is also stopped when another tab is selected to ensure communications aren't held up when trying to perform an operation from another page.

Clear Trace

This will clear the graph plotted and reset the cursor to the left hand side of the picture box.

Manual Controls and Presets

These work as per the controls on the Standard Controls page although instead of stopping when released the MIC will continually move until a separate stop command is sent. The numeric key pad controls also work whilst in pot test although the learn preset method using the number keys does not.

Pot Test Results



Pan / Tilt Pos

These indicate the current position in Pan and Tilt in Red and Blue respectively, over the range of 4096 units for 360 degrees rotation.

Pan / Tilt PWM

These indicate the current PWM (Pulse Width Modulation) of the motor, with Pan and Tilt being indicated in Green and Purple respectively. This gives an indication of how hard the motors are working.

Pan / Tilt Speed

These results are the actual speed that the MIC is moving in either axis. The results are not plotted on the graph only shown in the respective window.

PSU Level

This reading shows the Voltage level of the main power rail in the MIC. There are 2 scaling options for different control cards, as a guide 6E came into production around mid 2007, so anything after this would use this option.

Comms

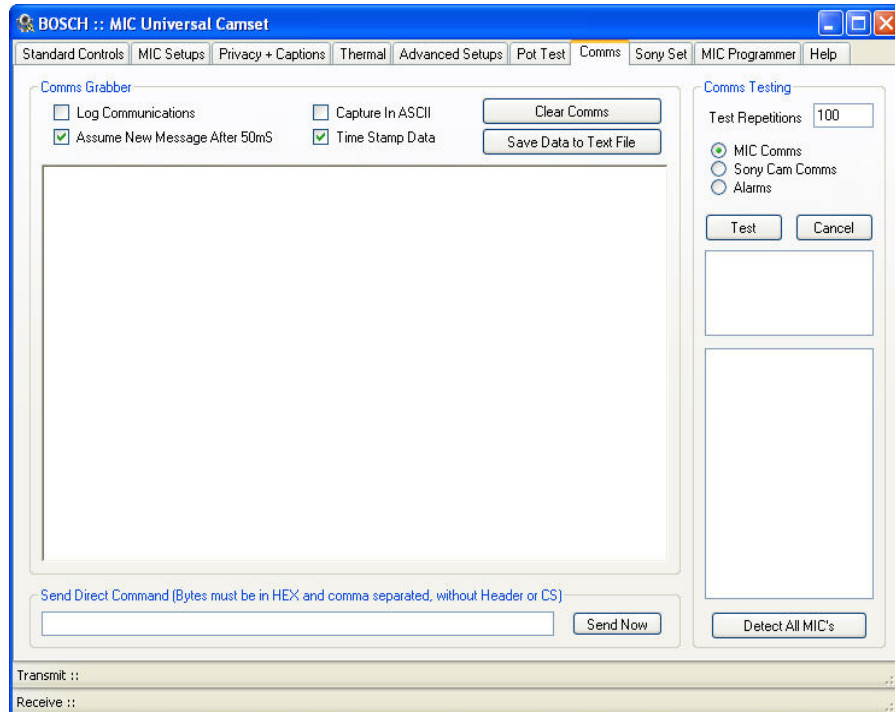

The **Comms** tab enables the user to monitor the communications to and from a MIC or any other serial device connected to the open comm port. This requires 2 way comms for any of the associated options.

Log Communications

This check box enables or disables the capture of incoming and outgoing data to the text display. With the Communications Grabber running the comms to and from the MIC will be slightly slowed down, which may be very noticeable on features such as Pot Test, so unless specifically required it would be advised that this is turned off.

Capture in ASCII

This changes the way in which the data is displayed. If not checked then the data is displayed in comma separated Hex bytes (e.g. 54, 45, 53, 54), if it is checked then each byte is converted into its corresponding ASCII char (e.g. TEST). However this only works if the protocol sends out valid ASCII bytes, all other values, less than 32 and over 127 will result in a "?" being printed.

Assume New Message after 50mS

This is a way of separating out consecutive commands and individually time stamping them. If there is a 50mS gap between transmitted or received bytes then the next byte is taken as a new message.

Time Stamp Data

If checked then each new packet will be titled with the date and time of transmission or reception, otherwise the data will just be indicated with a Transmit or Receive tag.

Clear Comms

This simply clears the current communications window.

Save Data to File

This will prompt the user for a file location where the comms can be saved. They will be output as a ".doc" file formatted in the same way as display in the window, which can be opened in Microsoft Word.

Send Direct Command

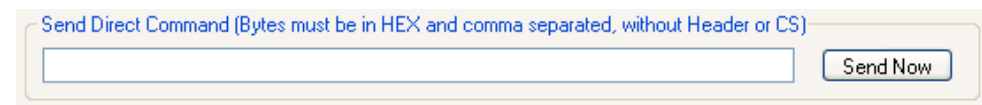

This feature enables the user specify an exact command in Hex bytes to send to the MIC. The long input box is used to enter the command in individual comma separated Hex bytes, without the header or CS.

For example a complete Learn Preset 1 command in FV protocol is:
0A 30 31 30 41 36 4D 30 31 80

The header on this is:
0A 30 31 30 41 36

and the checksum:
80

So to transmit the same command the input box should read:
4D, 30, 31

Any variation on this will cause an error to be flagged indicating why the command is wrong. Once written the command is sent using the [Send Now](#) command.

Communications Testing

Comms Testing

Test Repetitions

MIC Comms
 Sony Cam Comms
 Alarms

Communications Testing enables the user to test the quality of the communications link to the MIC. This does require 2 way comms for any of the below options. Use the [Cancel](#) button at any time to stop the testing process.

MIC Comms

To initiate, select the MIC Comms radio button and press Test. This will repeatedly query the MIC for a set response the number of times of which is defined by the Test Repetitions input box. If the response is valid and within the correct time frame then it is logged as a pass. No response or a late response is flagged as a time out and short or incorrect data is classed as a fail. The results of this are continually displayed in the small window directly below the Test button. Any faults along the length of the comms lines will normally result in fails or timeouts dependant on the severity of the problem.

Cam Comms

Starting this is as with MIC Comms but by selecting the Sony Cam Comms radio instead. So long as the MIC Comms are 100% reliable this will return the reliability of the comms to the Sony Module inside the MIC, again returning passes, fails and time outs in the same frame. If these are intermittent, please contact Bosch Security Systems for advice.

Alarms

This test monitors the state of the 8 alarm inputs if applicable, printing if they are turned On or Off continually throughout the test in the larger of the 2 results windows. The test is started by selecting Alarms from the options and pressing Test.

Detect All MICs

This sends out a request to each MIC address for its Software Version printing the Response and the respective address in the large results box. This can be used in conjunction with setting a site of multiple MICs all to address 0 (random address) to then find what address each is on and therefore regain control.

Sony Set

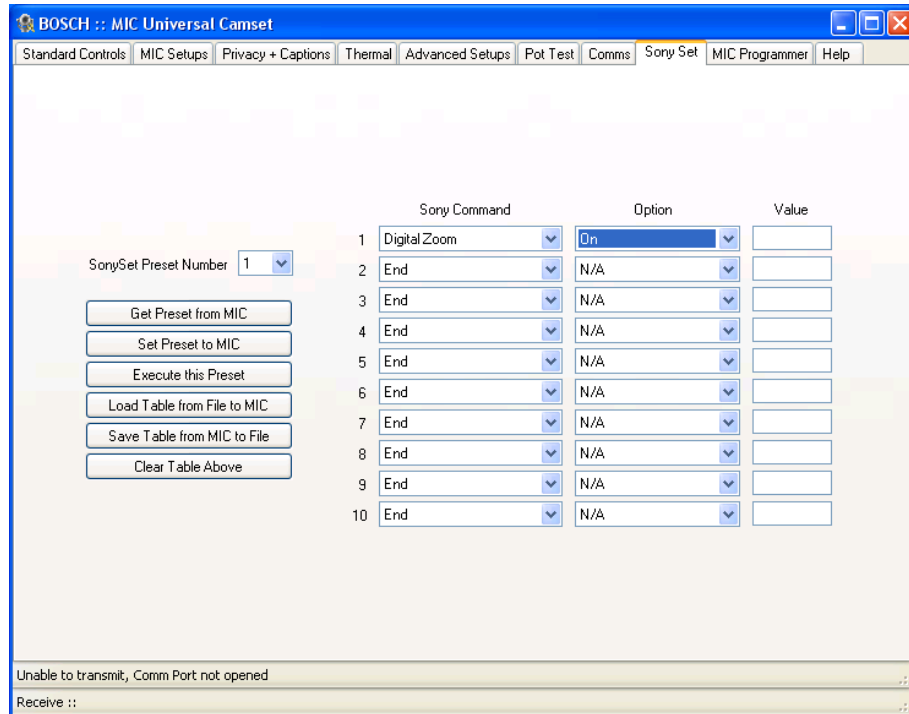

The **Sonyset** tab shows the controls required for Creating, Loading, Saving, Uploading and Downloading SonySet tables in FV protocol only.

A MIC can store 10 Sony Set tables, each containing 10 separate camera controls.

This means that a complete setup for the camera module (shutter speed, gain level, effect etc) can be saved and loaded back at any time through an input from the user. These can therefore be used to define certain camera states for different positions or requirements of an installation, for example, one could be set up for normal running auto everything, and another set-up for ANPR, with a specified frame rate and gain etc.

These states could then be toggled by calling them up with an **Execute SonySet** command.

SonySet Controls

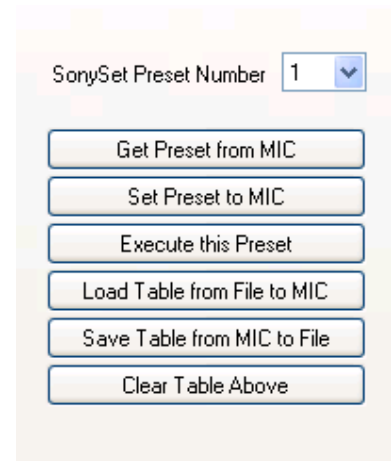

SonySet Preset Number

This is where the SonySet Preset number is selected, there are 10 options available relating to 10 complete camera setups.

Get Preset from MIC

This process will query the MIC for the table number as specified in the SonySet Preset Number list. Each valid command and value will be shown in the table. If any data is incorrect or the command does not exist the Sony Command column will display "Invalid". It is not advised to reprogram a MIC with any "Invalid" commands.

Send Preset to MIC

This will read through the entire table checking for valid commands and respective values indicating any discrepancies, and then form the commands to send the data to the MIC. The data is stored to the preset number as indicated in the SonySet Preset Number in list.



Execute this Preset

This will send a command to the MIC to read the commands from the preset number in SonySet Preset Number list in memory and send them on to the Sony module. This will only send commands stored not the ones in Camset, so to test a Setup first use [Send Preset](#) to MIC then [Execute this Preset](#).

Load Table from File to MIC

It is also possible to Load a complete table of all 10 presets directly into the MIC from a file. This will prompt the user to open an XML file containing all of the information required. The information will not be displayed in the table display, it will simply be sent straight to the MIC.

Save Table from MIC to File

This creates the files that can be used by the feature above. First it will prompt for a file location to store and if valid, poll the MIC for each command of each preset and store all of the information to an XML file.

Using the [Save](#) and [Load file](#) functions as above means it is possible to copy a complete SonySet table from one MIC to another to easily setup a site with the same configuration.

Clear Table

This clears the table in Camset and will not do anything to the data stored at the location in memory in the MIC itself. To clear a MIC table, use this function and then [Send Preset](#) to MIC.

The SonySet Table

	Sony Command	Option	Value
1	Digital Zoom	On	
2	End	N/A	
3	End	N/A	
4	End	N/A	
5	End	N/A	
6	End	N/A	
7	End	N/A	
8	End	N/A	
9	End	N/A	
10	End	N/A	

The table on the right of the form indicates the current state of one of the presets. The first column [Sony Command](#) indicates the command type for each of the 10 steps in each preset. The [Option](#) column indicates the current value for the chosen command, (e.g On or Off) or if the command is a direct set type, this will indicate the range available and the result is displayed in column 3, [Value](#).

A full list of available commands and values is shown below.

Changing any of the Sony Commands will invoke the corresponding Option to also change and take on the top value in the list of available options, therefore clearing the previous setting from memory. If the command type requires a numeric input, the corresponding Value box will indicate the lower bound of the range, which can then be changed to any valid value.



If only a few commands are utilised on the list then the rest should be set to "End" which will display "N/A" in the option column.

Below is a list of the available SonySet Commands and their corresponding Values or valid value ranges:

Table R – Sonyset Commands

Command	Value
Camera Power	On / Off
Zoom Set	0 to 28672
Digital Zoom	On / Off
Focus Set	4096 to 49152
Focus Mode	Auto / Manual
Focus Control	One Push Trigger / Force Infinity
AF Sensitivity	High / Low
Focus Near Limit	4096 to 49152
White Balance Mode	Auto / Indoor / Outdoor / One Push / Auto Tracing / Manual
White Balance Control	One Push Trigger
Red Gain Control	Reset / Plus 1 / Minus 1
Red Gain Set	0 to 255
Blue Gain Control	Reset / Plus 1 / Minus 1
Blue Gain Set	0 to 255
Exposure Mode	Auto / Manual / Shutter Priority / Iris Priority / Gain Priority / Bright / Shutter Auto / Iris Auto / Gain Auto
Slow Shutter Mode	Auto / Manual
Shutter Control	Reset / Plus 1 / Minus 1
Shutter Set	0 to 19
Iris Control	Reset / Plus 1 / Minus 1
Iris Set	0 to 19

Gain Control	Reset / Plus 1 / Minus 1
Gain Set	0 to 19
Bright Control	Reset / Plus 1 / Minus 1
Bright Set	0 to 19
Exposure Comp Control	Reset / Plus 1 / Minus 1
Exposure Comp Set	0 to 14
Exposure Comp Mode	On / Off
Backlight	On / Off
Aperature Control	Reset / Plus 1 / Minus 1
Aperature Set	0 to 19
Low Lux	On / Off
Hi Resolution	On / Off
Image Flip Horiz	On / Off
Freeze Frame	Off / Negative / Black & White
On Screen Data	On / Off
Caption Display	On / Off
Auto IR	On / Off
Camera Initialise	Lens Recal / Bad Pixel Correction
Image Flip	On / Off
End	N/A
Invalid	N/A



MIC Programmer

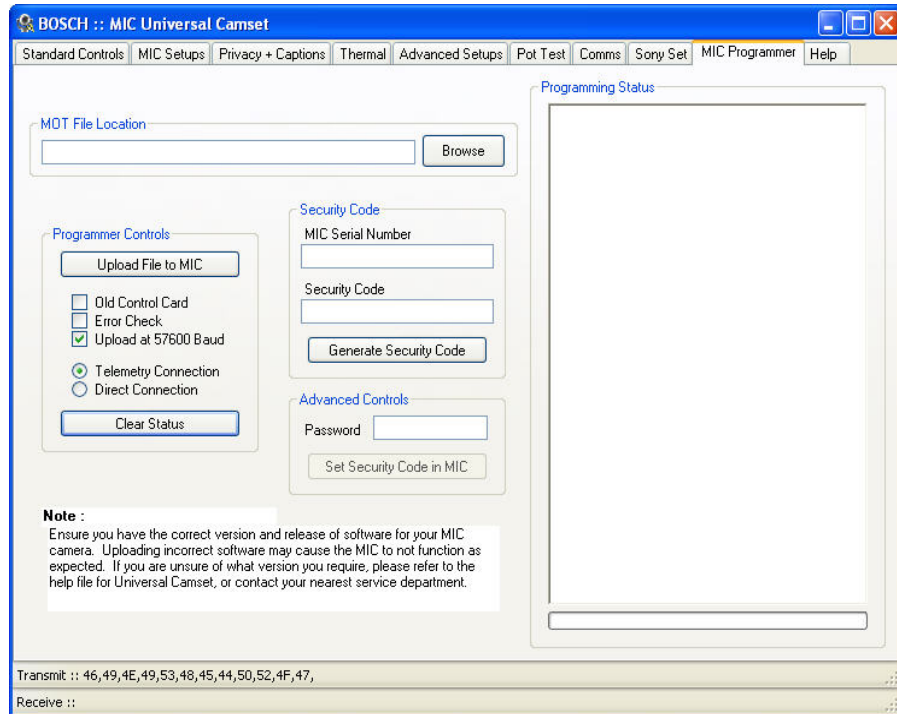

The MIC programmer allows users to change the protocol of the MIC400 camera unit; you must have the protocol file (.MOT) you wish to upload available, these are available on the CD with the MIC or from Bosch Security Systems.



CAUTION: Ensure you have the correct version and software for your MIC400. Uploading the wrong software may cause the MIC400 to function incorrectly. If you are unsure of which version you require, please contact Bosch.

To change a protocol loaded into a MIC400 please do the following:-

1. Connect the MIC400 to a PC running Universal Camset as described on page 27, check the MIC400 is communicating correctly with Camset; this can be checked using the Comms function.
2. Use the [Browse](#) button to locate the new .MOT file you wish to upload to the MIC400.



3. In the Security Code section, enter the MIC serial number in the appropriate field; click the [Generate Security Code](#) button. The security code will now be created.

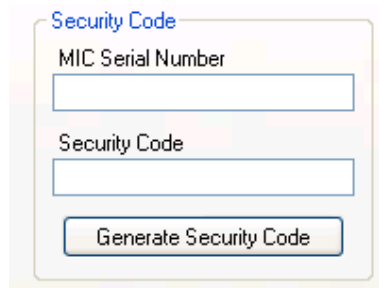

- Check the programming controls are correct, the default settings are usually correct and do not typically require adjustment. Error checking can be enabled to ensure an error free installation but this result in longer loading times.

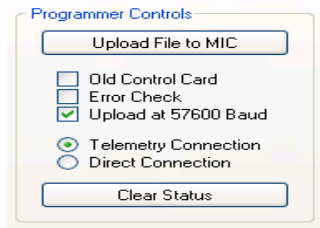

- Click the [Upload File to MIC](#) to begin the upload, the status of the connection and progress of the upload will be displayed on the panel to the right hand side. The programmer will complete the upload, perform error checking then disengage automatically when finished, alerting the user when completed.
- The MIC400 will now be loaded with the new protocol, camera control should be enabled immediately when the new protocol is selected under the [Standard Controls](#) tab but may require a reboot of the camera or closing and reselecting the USB in the comm port dropdown menu.

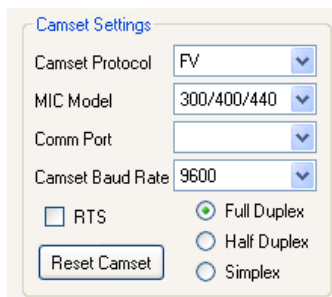

- After programming a MIC the status of the settings can be undefined, therefore it is good practice to reset them to the factory defaults then make any modifications required for the specific installation.

- Open the [MIC Setups](#) tab and clic the [Load Settings into Camset](#) button

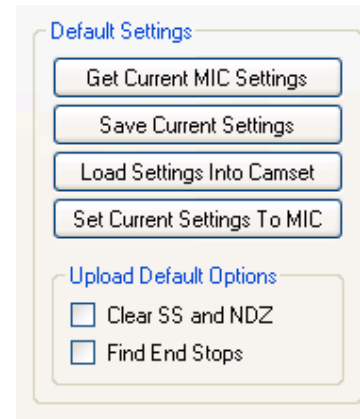

- The open dialog should automatically display the "MIC Defaults" directory in the Camset Install location from which the File "MIC Production Defaults.xml" can be loaded. This will setup all the Universal Camset controls as per the factory defaults for the MIC.
- Then click [Clear Softstops and NDZ](#) and [Find End Stops](#) tickboxes.

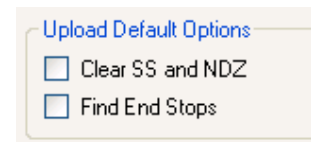

- Finally click the [Set Current Settings to MIC](#), the MIC will then perform the Endstop test and will slowly rotate to find the endstops, the whole process should take about a minute after which the MIC is ready to use the new protocol.

CHAPTER 5 **Technical Specifications****MIC400AL****CAMERA MODULE**

Image sensor	1/4" EXview CCD
Picture elements	380K NTSC / 440K PAL (WIDE)
Horizontal resolution	470TVL NTSC / 460TVL PAL (WIDE)
Filter	Automatic mechanical IR cut filter
Focus system	Auto or manual Iris
Synchronisation	Internal / External (V-Lock)
Recommended illumination	100 to 100,000 lx
Signal/Noise ratio	50dB or more
Back Light Compensation (BLC)	On/Off
White balance	Automatic
Automatic Gain Control (AGC)	-3 to -28 dB, 2dB steps
Aperture control	16 Steps

18x optical zoom module

Lens	F=4.1mm (WIDE) to 73.8mm (TELE), F1.4 to F3.0
Zoom	18x optical (12x digital)
Angle of view	48° (WIDE end) to 2.8° (TELE end)
Minimum illumination	0.7 lux (F1.4, 1/60s NTSC, 1/50s PAL), 0.11 lux (F1.4, 1/4s NTSC, 1/3s PAL), 0.01 lux or less (F1.4, 1/4s NTSC, 1/3s PAL, ICR ON)
Shutter speed	1/1 to 1/10,000s (22 steps) NTSC, PAL

36x optical zoom module

Lens	F=3.4mm (WIDE) to 122.4mm (TELE), F1.6 to F4.5
Zoom	36x optical (12x digital)
Angle of view	57.8° (WIDE end) to 1.7° (TELE end)
Minimum illumination	1.4 lux (1/60s NTSC, 1/50s PAL), 0.1 lux (1/4s NTSC, 1/3s PAL), 0.01 lux or less (1/4s NTSC, 1/3s PAL, ICR ON)
Shutter speed	1/4 to 1/10,000s (20 steps) NTSC, 1/3 to 1/10,000s (20 steps) PAL

OPERATIONAL*

Auto flip	Yes
Manual flip	Yes
Dynamic privacy zones	3D privacy masking with infinite zones (using optional privacy card)
Presets	64 telemetry presets utilising resolver technology (using FV protocol, 10 camera set-up presets to allow ANPR, colour correction etc.)
Preset tours	6 tours each with up to 32 presets with slow shutter integration
Sector titles	Yes (64 sectors) 20 characters per title
Preset titles	20 character caption for each of the 64 presets
Home position	Yes (preset 1 or tour)

COMMUNICATION & PROTOCOLS

Communication	RS485 / RS422
Control protocol	Refer to current supported protocol list

CONNECTIVITY

Video	Co-axial via composite cable
Telemetry	Twisted pair. Simplex, half and full duplex operation via composite cable
Power	Via composite cable

ALARMS

Alarm inputs	1 tamper input (additional inputs possible with optional alarm card in PSU)
Alarm communication	Tamper switch (ground connection)

MECHANICAL

Drive unit
Pan angle
Pan speed
Tilt angle
Tilt speed
Speed control
Preset accuracy
Proportional P/T to zoom

Integral pan/tilt motor drive
360° continuous rotation
Up to 90° per second (variable)
320°
0.2° to 90° per second (variable)
Closed loop electronics
Better than 0.08°
Yes

PHYSICAL

Construction material
Viewing window
Standard colours
Standard finish
Dimensions
Weight

6mm thick aluminum
Tempered flat glass
Black (RAL9005), Grey (RAL7001) or White (RAL9003)
Powder coated
205(W) x 360(H) x 165(D) mm (upright & inverted)
5.5Kg (including 4" PCD base)

ENVIRONMENTAL

Operational temperature
Weather proofing

-20°C to +50°C, (-30° with optional heater)
NEMA 4x / IP68

ELECTRICAL

Input voltage
Power consumption

15V AC / 18V DC
25.2W max

AVAILABLE OPTIONS

Configurations available
Colour/Finish
Camera module
Camera colour system
Installed protocol

Upright mount, inverted mount or upright canted at 45° mount options
Bespoke colours and finishes available on request
18x camera module or 36x camera module
NTSC or PAL
Choose from current protocol list

Telemetry control card
Window wiper
Washer

Washer pump drive card
Heater
Privacy board
Alarm card
Speakers
IR lamps

ACCESSORIES

Power supply
Mounting hardware
Cabling

Built-in
Optional, factory fit
Optional, (bracket and nozzle supplied only)
Optional, fitted in PSU
Optional, factory fit
Optional, factory fit
Optional, fitted in PSU
Optional, factory fit
Optional, factory fit, specify upright or inverted camera operation (uses special PSU)

Choose from 115V AC, 230V AC, 24V AC or 12V DC versions
Compatible with all MIC series bracketry
Optional. Choose from 2M, 10M, 20M or 25M versions



MIC400PA**CAMERA MODULE**

AS MIC400AL

TWIN SPEAKERS

Output	6W / 8 Ohms
Construction	Polyamide UL94 V0
Weatherproofing	IP67
Colour	RAL7035
Control	Third party amplifier

OPERATIONAL*

AS MIC400AL

COMMUNICATION & PROTOCOLS

AS MIC400AL

CONNECTIVITY

AS MIC400AL

ALARMS

AS MIC400AL

MECHANICAL

AS MIC400AL

PHYSICAL

Construction material	6mm thick aluminum
Viewing window	Tempered flat glass
Standard colours	Black (RAL9005), Grey (RAL7001) or White (RAL9003)
Standard finish	Powder coated
Dimensions	205(W) x 720(H) x 165(D) mm (upright & inverted)
Weight	6.5Kg (including 4" PCD base and speakers)

ENVIRONMENTAL

Operational temperature	-20°C to +50°C, No heater option available
Weatherproofing	NEMA 4x / IP68, Speakers IP67

ELECTRICAL

AS MIC400AL

AVAILABLE OPTIONS

AS MIC400AL

ACCESSORIES

AS MIC400AL



MIC400UL and MIC400UT**CAMERA MODULE**

AS MIC400AL

OPERATIONAL*

AS MIC400AL

COMMUNICATION & PROTOCOLS

AS MIC400AL

CONNECTIVITY

AS MIC400AL

ALARMS

AS MIC400AL

MECHANICAL

AS MIC400AL

PHYSICAL

Construction material	Aluminium - 6mm thick aluminum or Stainless steel – grade 316 stainless steel
Viewing window	Tempered flat glass
Standard colours	Aluminium – Black (RAL9005), Grey (RAL7001) or White (RAL9003)
Standard finish	Stainless steel – stainless steel Aluminium - powder coated
Dimensions	Stainless steel – stainless steel 205(W) x 360(H) x 165(D)mm (upright & inverted)
Weight	Aluminium - 5.5Kg (including 4" PCD base) Stainless steel – 16.5Kg (including 4" PCD base)

ENVIRONMENTAL

Operational temperature	-20°C to +50°C, (-30° with optional heater)
Weather proofing	NEMA 4x / IP68

ELECTRICAL

AS MIC400AL

AVAILABLE OPTIONS

Configurations available	Upright mount, inverted mount or upright canted at 45° mount options
Colour/Finish	Bespoke colours and finishes available on Request
Camera module	18x camera module or 36x camera module
Camera colour system	NTSC or PAL
Installed protocol	Choose from current protocol list
Telemetry control card	Built-in
Heater	Optional, factory fit
Privacy board	Optional, factory fit
Alarm card	Optional, fitted in PSU
Casing	Choice of aluminium or stainless steel

ACCESSORIES

Power supply	Choose from 115V AC, 230V AC, 24V AC or 12V DC versions (separate PSU enclosure needed for underwater operation)
Mounting hardware	Compatible with all MIC series bracketry
Cabling	Optional. choose from 2M, 10M, 20M or 25M versions

For other options see Version and Options



MIC400S**CAMERA MODULE**

AS MIC400AL

OPERATIONAL*

AS MIC400AL

COMMUNICATION & PROTOCOLS

AS MIC400AL

CONNECTIVITY

AS MIC400AL

ALARMS

AS MIC400AL

MECHANICAL

AS MIC400AL

PHYSICAL

Construction material	Grade 316 stainless steel
Viewing window	Tempered flat glass
Standard colours	Stainless steel (no colour options)
Standard finish	Stainless steel (no finish options)
Dimensions	205(W) x 360(H) x 165(D) mm (upright & inverted)
Weight	16.5Kg

ENVIRONMENTAL

Operational temperature	-20°C to +50°C, (-30° with optional heater)
Weather proofing	NEMA 4x / IP68

ELECTRICAL

AS MIC400AL

AVAILABLE OPTIONS

AS MIC400AL

ACCESSORIES

AS MIC400AL



MIC400IR**CAMERA MODULE**

AS MIC400AL

IR ILLUMINATORS

LED array	High efficiency Surface Mount (SMT) LEDs
No of LEDs	7 per lamp
Wavelength	850nm (semi-covert)
Beam angle	30°
IR distance	55 meters
Weather proofing	IP68
Construction material	Aluminium with acrylic font window
IR technology	Black Diamond™ for even illumination across the entire scene
Power consumption	9W nominal per lamp on full power, 18W total for twin IR
Current	700mA per lamp

OPERATIONAL*

AS MIC400AL

COMMUNICATION & PROTOCOLS

AS MIC400AL

CONNECTIVITY

AS MIC400AL

ALARMS

Alarm inputs	1 tamper input and 4 alarm inputs in PSU
Alarm communication	Tamper switch (ground connection)

MECHANICAL

AS MIC400AL

PHYSICAL

Construction material	6mm thick aluminum
Viewing window	Tempered flat glass
Standard colours	Black (RAL9005), Grey (RAL7001) or White (RAL9003)
Standard finish	Powder coated
Dimensions	385(W) x 360(H) x 165(D) mm (upright & inverted) 385(W) x 330(H) x 217(D) mm (canted)
Weight	6.5Kg (including 4" PCD base)

ENVIRONMENTAL

AS MIC400AL

ELECTRICAL

Input voltage	15V AC / 18V DC
Power consumption	Max 50W

AVAILABLE OPTIONS

Configurations available	Upright mount, inverted mount or upright canted at 45° mount options
Colour/Finish	Bespoke colours and finishes available on request
Camera module	18x camera module or 36x camera module
Camera colour system	NTSC or PAL
Installed protocol	Choose from current protocol list
Telemetry control card	Built-in
Window wiper	Optional, factory fit
Washer	Optional, factory fit (bracket and nozzle supplied only)



Washer pump drive card	Optional, fitted in PSU
Privacy board	Optional, factory fit
Alarm card	Optional, fitted in PSU
IR lamps	Specify upright, canted or inverted camera operation

ACCESSORIES

Power supply	Choose from 115V AC, 230V AC or 12V DC versions (IR Specific PSU)
Mounting hardware	Compatible with all MIC1 series bracketry
Cabling	Optional choose from 2M, 10M, 20M or 25M versions

Dimension Drawings

MIC400AL, UL, UT and S models; Upright (90°) Dimension Drawings

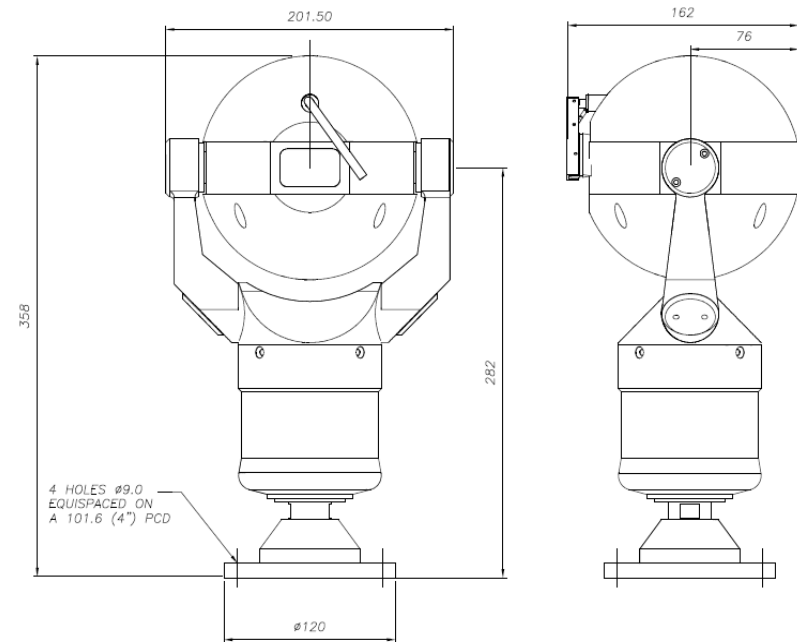

FORWARD VISION CCTV MIC1-400
OUTLINE DRAWING



MIC400IR Upright (90°) Orientation Dimension Drawings

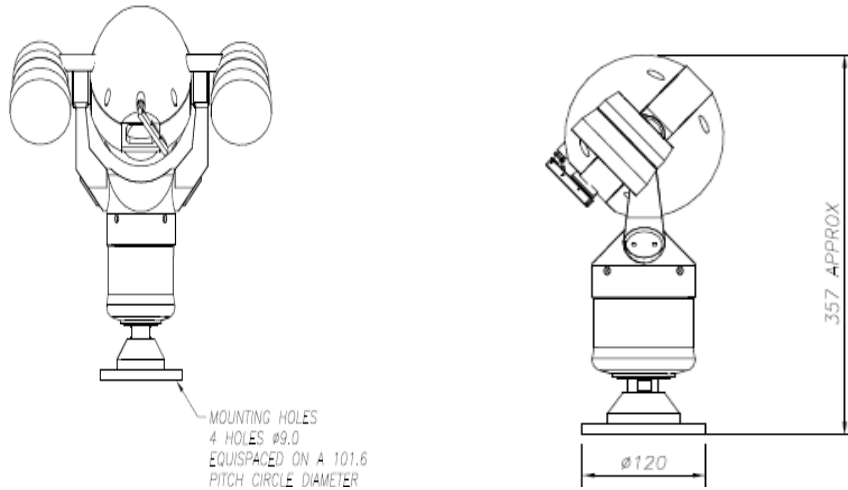

MIC400IR Plan View Dimension Drawings

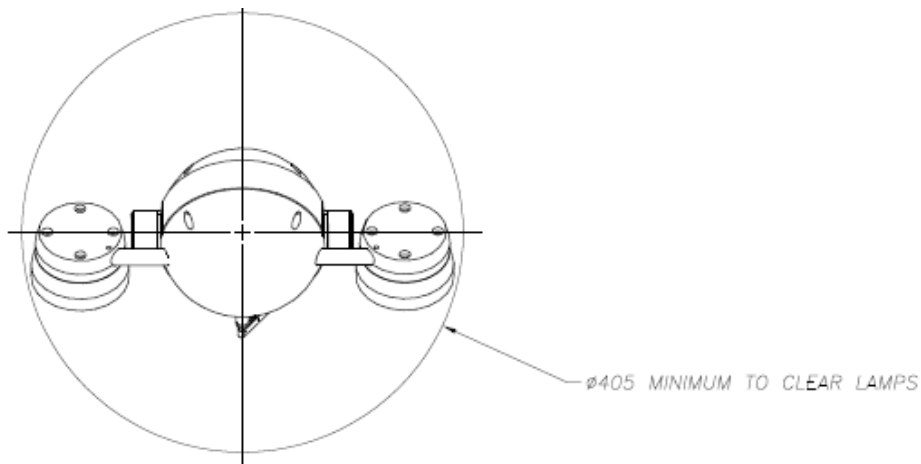

Contact

Americas

Bosch Security Systems Inc

850 Greenfield Road

Lancaster

Pennsylvania 17601

USA

Telephone +1 888-289-0096

Fax +1 585-223-9180

Email: security.sales@us.bosch.comwww.boschsecurity.us

Europe, Middle East, Africa

Bosch Security Systems B.V

P.O Box 80002

5600 JB Eindhoven

The Netherlands

Phone +31 40 2577 284

Fax +31 40 2577 330

emea.securitysystems@bosch.com

www.boschsecurity.com

Asia-Pacific

Bosch Security Systems Pte Ltd

38C Jalan Pemimpin

Singapore 577180

Phone +65 6319 3450

Fax +65 6319 3499

apr.securitysystems@bosch.com

www.boschsecurity.com

© Bosch Security Systems B.V, 2009, Data subject to change without



Appendices

Appendix A – Protocol Preset codes

PRESET CODES

Pelco

MULTI_ALARM_PRESET	16	// 16 to 24
NORMAL_TILT_LIMIT_PRESET	26	
IR_LAMP_TILT_LIMIT_PRESET	27	
BAUD_2400	28	
TILT_REVERSE_PRESET	29	// toggle
IMAGE_FLIP_PRESET	30	// toggle
REMAP_AN_AUX	31	
PHOTOCELL_IR_ON_PRESET	32	
PHOTOCELL_IR_OFF_PRESET	33	
AUTOHOME_SEQUENCE_PRESET	35	
AUTOHOME_OFF_PRESET	36	
AUTO_IR_ON_PRESET	37	
AUTO_IR_OFF_PRESET	38	
CANTED_PRESET	39	
BAUD_9600	40	

BAUD_4800	41
WASHWIPE_PRESET	42
AUTO_ALARM_GOTO_PRESET	43
FIND_END_STOPS	45
SEQUENCE_RECORD_PRESET	48
SEQUENCE_RECORD_STOP_PRESET	49
SET_TOUR1_PRESET	50
//	51
//	52
//	53
//	54
SET_TOUR6_PRESET	55
AUTO_ALARM_ON_PRESET	56
AUTO_ALARM_OFF_PRESET	57
AUTO_LOWLIGHT_ON_PRESET	58
AUTO_LOWLIGHT_OFF_PRESET	59
ADDRESS_CHANGE_PRESET	60
PRIVACY_PRESET_START	61
PRIVACY_PRESET_END	75
AUTOFLIP_ON_PRESET	76



AUTOFLIP_OFF_PRESET	77		STOP_SCAN_PRESET	96	// goto presets
WASHWIPE_ON_PRESET	78		RANDOM_SCAN_START_PRESET	97	
WASHWIPE_OFF_PRESET	79		FRAME_SCAN_START_PRESET	98	
INVERTED_PRESET	80		AUTO_SCAN_START_PRESET	99	
UPRIGHT_PRESET	81		AUTOHOME_10S_PRESET	40	// goto preset codes
MULTI_ALARM_ON_PRESET	82		AUTOHOME_30S_PRESET	41	
MULTI_ALARM_OFF_PRESET	83		AUTOHOME_1M_PRESET	42	
DIGITAL_ZOOM_DISABLE	84		AUTOHOME_5M_PRESET	43	
DIGITAL_ZOOM_ENABLE	85		AUTOHOME_10M_PRESET	44	
PTZ_SCALE_ON_PRESET	86		FAST_SHUTTER_PRESET	45	
PTZ_SCALE_OFF_PRESET	87	//defines for limit setting presets	NORMAL_SHUTTER_PRESET	46	
SOFTLIMIT_TOP_LEFT_PRESET	88	// Always lowest number	PRIVACY_SET_WHOLE	75	// learn preset
SOFTLIMIT_BOTTOM_RIGHT_PRESET	89		PRIVACY_CLEAR_WHOLE	74	
NONDWELL_TOP_LEFT_PRESET	90		PRIVACY_UNCOVER_ALL	73	
NONDWELL_BOTTOM_RIGHT_PRESET	91	// Always highest number	PRIVACY_REPLACE_ALL	72	
SCAN_LIMIT_LEFT_PRESET	92	// Always lowest number	PRIVACY_SHOW_STYLE	71	
SCAN_LIMIT_RIGHT_PRESET	93		PRIVACY_HIDE_STYLE	70	
CAMERA_RECALIBRATE_PRESET	94		PRIVACY_SET_STYLE	69	
SCAN_SPEED_SET_PRESET	95		PRIVACY_SET_CENTRAL	68	



PRIVACY_CLEAR_CENTRAL	67		SHOW_STARTUP_MESS	99	
PRIVACY_SHOW_CURSOR	66				
PRIVACY_HIDE_CURSOR	65		SPECIAL SETUP PRESETS		
PRIVACY_SAVE_PARAMETER	64		PICTURE_FLIP_MIRROR_ON_PRESET	188	
PRIVACY_LOAD_PARAMETER	63		PICTURE_FLIP_MIRROR_OFF_PRESET	189	
PRIVACY_INIT_PARAMETER	62		TILT_REVERSE_ON_PRESET	190	
PRIVACY_SET_CURSOR	61		TILT_REVERSE_OFF_PRESET	191	
CAMERA_COMMAND_PRESET1	240		PHOTOCELL_IR_ON_PRESET	192	
CAMERA_COMMAND_PRESET10	250		PHOTOCELL_IR_OFF_PRESET	193	
RESET_PRESETS_PRESET	255		PAN_REVERSE_ON_PRESET	194	
360 Vision			PAN_REVERSE_OFF_PRESET	195	
WASHWIPE_PRESET	64		AUTO_IR_ON_PRESET	196	
AUTO_ALARM_GOTO_PRESET	65		AUTO_IR_OFF_PRESET	197	
WIPE_ON	66		INTERMITANT_WIPE_ON_PRESET	198	
WIPE_OFF	67		INTERMITANT_WIPE_OFF_PRESET	199	//defines for limit setting presets
ON_SCREEN_DSIPLAY_TOGGLE	68		SOFTLIMIT_TOP_LEFT_PRESET	200	// Always lowest number
WASH_START_PRESET	69		SOFTLIMIT_BOTTOM_RIGHT_PRESET	201	
WASH_FINISH_PRESET	70		NONDWELL_TOP_LEFT_PRESET	202	
MULTI_ALARM_PRESET	50	// allow up to 12 alarms now.	NONDWELL_BOTTOM_RIGHT_PRESET	203	// Always highest number
FIND_END_STOPS	98		AUTOHOME_PRESET1_PRESET	204	



AUTOHOME_SEQUENCE_PRESET	205	PRIVACY_SET_STYLE	229
AUTOHOME_OFF_PRESET	206	PRIVACY_SET_CENTRAL	228
MULTI_ALARM_ON_PRESET	207	PRIVACY_CLEAR_CENTRAL	227
MULTI_ALARM_OFF_PRESET	208	PRIVACY_SHOW_CURSOR	226
DIGITAL_ZOOM_DISABLE	209	PRIVACY_HIDE_CURSOR	225
DIGITAL_ZOOM_ENABLE	210	PRIVACY_SAVE_PARAMETER	224
SET_TOUR1_PRESET	211	PRIVACY_LOAD_PARAMETER	223
SET_TOUR6_PRESET	216	PRIVACY_INIT_PARAMETER	222
AUTOFLIP_ON_PRESET	217	PRIVACY_SET_CURSOR	221
AUTOFLIP_OFF_PRESET	218	AUTO_ALARM_ON_PRESET	236
WASHWIPE_ON_PRESET	219	AUTO_ALARM_OFF_PRESET	237
WASHWIPE_OFF_PRESET	220	AUTO_LOWLIGHT_ON_PRESET	238
PRIVACY_PRESET_START	221	AUTO_LOWLIGHT_OFF_PRESET	239
PRIVACY_PRESET_END	235	CAMERA_COMMAND_PRESET1	240
PRIVACY_SET_WHOLE	235	CAMERA_COMMAND_PRESET10	250
PRIVACY_CLEAR_WHOLE	234	CAMERA_RECALIBRATE_PRESET	251
PRIVACY_UNCOVER_ALL	233	RESET_PRESETS_PRESET	255
PRIVACY_REPLACE_ALL	232		
PRIVACY_SHOW_STYLE	231		
PRIVACY_HIDE_STYLE	230		



American Dynamics

WASHWIPE_PRESET 52

AUTO_ALARM_GOTO_PRESET 53

MULTI_ALARM_PRESET 28 // allow up to 12 alarms
now. 28->40**SPECIAL SETUP PRESETS**

PAN_REVERSE_ON_PRESET 54

PAN_REVERSE_OFF_PRESET 55

AUTO_IR_ON_PRESET 56

AUTO_IR_OFF_PRESET 57

INTERMITANT_WIPE_ON_PRESET 58

INTERMITANT_WIPE_OFF_PRESET 59 //defines for limit setting
Presets

SOFTLIMIT_TOP_LEFT_PRESET 60 // Always lowest number

SOFTLIMIT_BOTTOM_RIGHT_PRESET 61

NONDWELL_TOP_LEFT_PRESET 62

NONDWELL_BOTTOM_RIGHT_PRESET 63 // Always highest number

AUTOHOME_PRESET1_PRESET 64

AUTOHOME_SEQUENCE_PRESET 65

AUTOHOME_OFF_PRESET 66

MULTI_ALARM_ON_PRESET 67

MULTI_ALARM_OFF_PRESET 68

DIGITAL_ZOOM_DISABLE 69

DIGITAL_ZOOM_ENABLE 70

SET_TOUR1_PRESET 71

SET_TOUR6_PRESET 76

AUTOFLIP_ON_PRESET 77

AUTOFLIP_OFF_PRESET 78

WASHWIPE_ON_PRESET 79

WASHWIPE_OFF_PRESET 80

PRIVACY_PRESET_START 81

PRIVACY_PRESET_END 95

PRIVACY_SET_WHOLE 95

PRIVACY_CLEAR_WHOLE 94

PRIVACY_UNCOVER_ALL 93

PRIVACY_REPLACE_ALL 92

PRIVACY_SHOW_STYLE 91

PRIVACY_HIDE_STYLE 90

PRIVACY_SET_STYLE 89

PRIVACY_SET_CENTRAL 88

PRIVACY_CLEAR_CENTRAL 87



PRIVACY_SHOW_CURSOR	86		Kalatel		
PRIVACY_HIDE_CURSOR	85		LEFTAUTOPANLIMIT	62	//Dont change this part of Kalatel protocol
PRIVACY_SAVE_PARAMETER	84		RIGHTAUTOPANLIMIT	63	//Dont change this part of Kalatel protocol
PRIVACY_LOAD_PARAMETER	83		WASHWIPE_PRESET	48	
PRIVACY_INIT_PARAMETER	82		AUTO_ALARM_GOTO_PRESET	49	
PRIVACY_SET_CURSOR	81		MULTI_ALARM_PRESET	57	// allow up to 12 alarms now.
AUTO_ALARM_ON_PRESET	46		PAN_REVERSE_ON_PRESET	56	
AUTO_ALARM_OFF_PRESET	47		PAN_REVERSE_OFF_PRESET	55	
AUTO_LOWLIGHT_ON_PRESET	48		AUTO_IR_OFF_PRESET	54	
AUTO_LOWLIGHT_OFF_PRESET	49		INTERMITANT_WIPE_ON_PRESET	53	
CAMERA_COMMAND_PRESET1	240		INTERMITANT_WIPE_OFF_PRESET	52	//defines for limit setting presets
CAMERA_COMMAND_PRESET10	250		SOFTLIMIT_TOP_LEFT_PRESET	48	// Always lowest number
CAMERA_RECALIBRATE_PRESET	50		SOFTLIMIT_BOTTOM_RIGHT_PRESET	49	
RESET_PRESETS_PRESET	51	// Normal Operation presets (Goto)	NONDWELL_TOP_LEFT_PRESET	50	
AD_WIPER	70		NONDWELL_BOTTOM_RIGHT_PRESET	51	// Alway highest number
AD_WASHER	71		AUTOHOME_SEQUENCE_PRESET	47	
AD_LAMPS_ON	72		AUTOHOME_OFF_PRESET	46	
AD_LAMPS_OFF	73		MULTI_ALARM_ON_PRESET	45	
AD_OSD	74				



MULTI_ALARM_OFF_PRESET	44		PRIVACY_PRESET_END	235
DIGITAL_ZOOM_DISABLE	43		PRIVACY_SET_WHOLE	235
DIGITAL_ZOOM_ENABLE	42		PRIVACY_CLEAR_WHOLE	234
AUTOFLIP_ON_PRESET	41		PRIVACY_UNCOVER_ALL	233
AUTOFLIP_OFF_PRESET	40		PRIVACY_REPLACE_ALL	232
WASHWIPE_ON_PRESET	39		PRIVACY_SHOW_STYLE	231
WASHWIPE_OFF_PRESET	38		PRIVACY_HIDE_STYLE	230
AUTO_ALARM_ON_PRESET	37		PRIVACY_SET_STYLE	229
AUTO_ALARM_OFF_PRESET	36		PRIVACY_SET_CENTRAL	228
AUTO_LOWLIGHT_OFF_PRESET	35		PRIVACY_CLEAR_CENTRAL	227
CAMERA_COMMAND_PRESET1	34		PRIVACY_SHOW_CURSOR	226
CAMERA_COMMAND_PRESET10	33		PRIVACY_HIDE_CURSOR	225
CAMERA_RECALIBRATE_PRESET	32		PRIVACY_SAVE_PARAMETER	224
RESET_PRESETS_PRESET	31	// Impossible to reach these presets	PRIVACY_LOAD_PARAMETER	223
AUTOHOME_PRESET1_PRESET	204		PRIVACY_INIT_PARAMETER	222
SET_TOUR1_PRESET	211		PRIVACY_SET_CURSOR	221
SET_TOUR6_PRESET	216		AUTO_IR_ON_PRESET	196
PRIVACY_PRESET_START	221			
AUTO_LOWLIGHT_ON_PRESET	238			



Molynx

MULTI_ALARM_PRESET	24	//defines for limit setting presets	SET_TOUR1_PRESET	51 //211
WASHWIPE_PRESET	32		SET_TOUR6_PRESET	56 //216
AUTO_ALARM_GOTO_PRESET	33	//defines for limit setting presets	AUTOFLIP_ON_PRESET	57 //217
AUTOHOME_PRESET1_PRESET	35		AUTOFLIP_OFF_PRESET	58 //218
AUTOHOME_SEQUENCE_PRESET	36		WASHWIPE_ON_PRESET	59 //219
AUTOHOME_OFF_PRESET	37		WASHWIPE_OFF_PRESET	60 //220
INTERMITANT_WIPE_ON_PRESET	38		PRIVACY_PRESET_START	61 //221
INTERMITANT_WIPE_OFF_PRESET	39		PRIVACY_PRESET_END	75 //235
SOFTLIMIT_TOP_LEFT_PRESET	40 //200		PRIVACY_SET_WHOLE	75 //235
SOFTLIMIT_BOTTOM_RIGHT_PRESET	41 //201		PRIVACY_CLEAR_WHOLE	74 //234
NONDWELL_TOP_LEFT_PRESET	42 //202		PRIVACY_UNCOVER_ALL	73 //233
NONDWELL_BOTTOM_RIGHT_PRESET	43 //203		PRIVACY_REPLACE_ALL	72 //232
AUTO_IR_ON_PRESET	45		PRIVACY_SHOW_STYLE	71 //231
AUTO_IR_OFF_PRESET	46		PRIVACY_HIDE_STYLE	70 //230
MULTI_ALARM_ON_PRESET	47 //207		PRIVACY_SET_STYLE	69 //229
MULTI_ALARM_OFF_PRESET	48 //208		PRIVACY_SET_CENTRAL	68 //228
DIGITAL_ZOOM_DISABLE	49 //209		PRIVACY_CLEAR_CENTRAL	67 //227
DIGITAL_ZOOM_ENABLE	50 //210		PRIVACY_SHOW_CURSOR	66 //226
			PRIVACY_HIDE_CURSOR	65 //225



PRIVACY_SAVE_PARAMETER	64 //224	Panasonic	
PRIVACY_LOAD_PARAMETER	63 //223	RELAY_TIME_START	252
PRIVACY_INIT_PARAMETER	62 //222	ALARM_SETTINGS_START	235 //16 modes
PRIVACY_SET_CURSOR	61 //221	SET_TOUR1_PRESET	87
AUTO_ALARM_ON_PRESET	76 //236	SET_TOUR6_PRESET	92
AUTO_ALARM_OFF_PRESET	77 //237	CAMERA_COMMAND_PRESET1	76
AUTO_LOWLIGHT_ON_PRESET	78 //238	CAMERA_COMMAND_PRESET10	86
AUTO_LOWLIGHT_OFF_PRESET	79 //239	AUTOFLIP_ON_PRESET	73
CAMERA_COMMAND_PRESET1	80 //240	AUTOFLIP_OFF_PRESET	72
CAMERA_COMMAND_PRESET10	90 //250	INTERMITANT_WIPE_ON_PRESET	71
CAMERA_RECALIBRATE_PRESET	91 //251	INTERMITANT_WIPE_OFF_PRESET	70
ON_SCREEN_DISPLAY_ON_PRESET	92 //236	RESET_PRESETS_PRESET	69
ON_SCREEN_DISPLAY_OFF_PRESET	93 //236	AUTOHOME_SEQUENCE_PRESET	68
INVERT_PRESET	94	CAMERA_RECALIBRATE_PRESET	67
RESET_PRESETS_PRESET	95 //255	DIGITAL_ZOOM_DISABLE	66
FIND_END_STOPS	96	DIGITAL_ZOOM_ENABLE	65
		#define MENU_ON_OFF	63 //Dont change
		MENU_ENTER	64 //Dont change
		WASHWIPE_ON_PRESET	62
		WASHWIPE_OFF_PRESET	61



#define OSD_ON	60	PRIVACY_UNCOVER_ALL	43	
PAN_REVERSE_ON_PRESET	59	PRIVACY_REPLACE_ALL	42	
PAN_REVERSE_OFF_PRESET	58	PRIVACY_SHOW_STYLE	41	
AUTO_IR_ON_PRESET	57	PRIVACY_HIDE_STYLE	40	
AUTO_IR_OFF_PRESET	56	PRIVACY_SET_STYLE	39	
AUTO_ALARM_ON_PRESET	55	PRIVACY_SET_CENTRAL	38	
AUTO_ALARM_OFF_PRESET	54	PRIVACY_CLEAR_CENTRAL	37	
MULTI_ALARM_ON_PRESET	53	PRIVACY_SHOW_CURSOR	36	
MULTI_ALARM_OFF_PRESET	52	PRIVACY_HIDE_CURSOR	35	
AUTOHOME_OFF_PRESET	51	PRIVACY_SAVE_PARAMETER	34	
AUTOHOME_PRESET1_PRESET	50	PRIVACY_LOAD_PARAMETER	33	
AUTO_ALARM_GOTO_PRESET	49	PRIVACY_INIT_PARAMETER	32	
WASHWIPE_PRESET	48	PRIVACY_SET_CURSOR	31	
AUTO_LOWLIGHT_ON_PRESET	47	SOFTLIMIT_TOP_LEFT_PRESET	27	// Always lowest number
AUTO_LOWLIGHT_OFF_PRESET	46	SOFTLIMIT_BOTTOM_RIGHT_PRESET	28	
PRIVACY_PRESET_START	31	NONDWELL_TOP_LEFT_PRESET	29	
PRIVACY_PRESET_END	45	NONDWELL_BOTTOM_RIGHT_PRESET	30	// Always highest number
PRIVACY_SET_WHOLE	45	MULTI_ALARM_PRESET	14	// allows up to 12 alarms now.
PRIVACY_CLEAR_WHOLE	44			



Bosch

		//AUTO_ALARM_OFF_PRESET	237	
PRIVACY_PRESET_START	100			
		//AUTO_LOWLIGHT_ON_PRESET	238	
PRIVACY_PRESET_END	114			
		//AUTO_LOWLIGHT_OFF_PRESET	239	
PRIVACY_SET_WHOLE	114			
		//CAMERA_COMMAND_PRESET1	240	
PRIVACY_CLEAR_WHOLE	113			
		//CAMERA_COMMAND_PRESET10	250	
PRIVACY_UNCOVER_ALL	112			
		MULTI_ALARM_PRESET	// 35,36,37,38,39,40,41,42	
PRIVACY_REPLACE_ALL	111			
		WASHWIPE_PRESET	47	
PRIVACY_SHOW_STYLE	110			
		AUTOHOME_PRESET	48	
PRIVACY_HIDE_STYLE	109			
		AUTO_ALARM_GOTO_PRESET	49	
PRIVACY_SET_STYLE	108			
		AUX1_PRESET	50	
PRIVACY_SET_CENTRAL	107			
		AUX26_PRESET	97	//defines for limit setting presets
PRIVACY_CLEAR_CENTRAL	106			
		SOFTLIMIT_TOP_LEFT_PRESET	95	// Always lowest number
PRIVACY_SHOW_CURSOR	105			
		SOFTLIMIT_BOTTOM_RIGHT_PRESET	96	
PRIVACY_HIDE_CURSOR	104			
		NONDWELL_TOP_LEFT_PRESET	97	
PRIVACY_SAVE_PARAMETER	103			
		NONDWELL_BOTTOM_RIGHT_PRESET	98	// Always highest number
PRIVACY_LOAD_PARAMETER	102			
		RESET_PRESETS_PRESET	99	
PRIVACY_INIT_PARAMETER	101			
PRIVACY_SET_CURSOR	100			
FIND_END_STOPS	115			
//AUTO_ALARM_ON_PRESET	236			



Forward Vision

WASHWIPE_PRESET	62
AUTO_ALARM_GOTO_PRESET	63
MULTI_ALARM_PRESET	50
FIND_END_STOPS	98
SHOW_STARTUP_MESS	99

// allow up to 12 alarms
now.

SPECIAL SETUP PRESETS

PICTURE_FLIP_MIRROR_ON_PRESET	188
PICTURE_FLIP_MIRROR_OFF_PRESET	189
TILT_REVERSE_ON_PRESET	190
TILT_REVERSE_OFF_PRESET	191
PHOTOCELL_IR_OFF_PRESET	193
PAN_REVERSE_ON_PRESET	194
PAN_REVERSE_OFF_PRESET	195
AUTO_IR_ON_PRESET	196
AUTO_IR_OFF_PRESET	197
INTERMITANT_WIPE_ON_PRESET	198
INTERMITANT_WIPE_OFF_PRESET	199
SOFTLIMIT_TOP_LEFT_PRESET	200

// Always lowest number
//defines for limit setting
presets

SOFTLIMIT_BOTTOM_RIGHT_PRESET	201	
NONDWELL_TOP_LEFT_PRESET	202	
NONDWELL_BOTTOM_RIGHT_PRESET	203	// Always highest number
AUTOHOME_PRESET1_PRESET	204	
AUTOHOME_SEQUENCE_PRESET	205	
AUTOHOME_OFF_PRESET	206	
MULTI_ALARM_ON_PRESET	207	
MULTI_ALARM_OFF_PRESET	208	
DIGITAL_ZOOM_DISABLE	209	
DIGITAL_ZOOM_ENABLE	210	
SET_TOUR1_PRESET	211	
SET_TOUR6_PRESET	216	
AUTOFLIP_ON_PRESET	217	
AUTOFLIP_OFF_PRESET	218	
WASHWIPE_ON_PRESET	219	
WASHWIPE_OFF_PRESET	220	
PRIVACY_PRESET_START	221	
PRIVACY_PRESET_END	235	
PRIVACY_SET_WHOLE	235	



PRIVACY_CLEAR_WHOLE	234	CAMERA_RECALIBRATE_PRESET	251	
PRIVACY_UNCOVER_ALL	233	RESET_PRESETS_PRESET	255	
PRIVACY_REPLACE_ALL	232	VCL		
PRIVACY_SHOW_STYLE	231	MULTI_ALARM_PRESET	50	// allow up to 12 alarms now.
PRIVACY_HIDE_STYLE	230	WASHWIPE_PRESET	62	
PRIVACY_SET_STYLE	229	AUTO_ALARM_GOTO_PRESET	63	
PRIVACY_SET_CENTRAL	228	DM_PRESETS	64	
PRIVACY_CLEAR_CENTRAL	227	NORMAL_PRESETS	65	
PRIVACY_SHOW_CURSOR	226	FIND_END_STOPS	66	
PRIVACY_HIDE_CURSOR	225	PICTURE_FLIP_MIRROR_ON_PRESET	69	
PRIVACY_SAVE_PARAMETER	224	PICTURE_FLIP_MIRROR_OFF_PRESET	70	
PRIVACY_LOAD_PARAMETER	223	TILT_REVERSE_ON_PRESET	71	
PRIVACY_INIT_PARAMETER	222	TILT_REVERSE_OFF_PRESET	72	//defines for limit setting presets
PRIVACY_SET_CURSOR	221	PRIVACY_PRESET_START	81	
AUTO_ALARM_ON_PRESET	236	PRIVACY_PRESET_END	95	
AUTO_ALARM_OFF_PRESET	237	PRIVACY_SET_WHOLE	95	
AUTO_LOWLIGHT_ON_PRESET	238	PRIVACY_CLEAR_WHOLE	94	
AUTO_LOWLIGHT_OFF_PRESET	239	PRIVACY_UNCOVER_ALL	93	
CAMERA_COMMAND_PRESET1	240	PRIVACY_REPLACE_ALL	92	
CAMERA_COMMAND_PRESET10	250			



PRIVACY_SHOW_STYLE	91	MULTI_ALARM_ON_PRESET	109	
PRIVACY_HIDE_STYLE	90	MULTI_ALARM_OFF_PRESET	110	
PRIVACY_SET_STYLE	89	PAN_TILT_SCALE_ON_PRESET	111	//vcl keyboard does this, but baxall doesn't!
PRIVACY_SET_CENTRAL	88	PAN_TILT_SCALE_OFF_PRESET	112	
PRIVACY_CLEAR_CENTRAL	87	CAMERA_OFF_PRESET	113	
PRIVACY_SHOW_CURSOR	86	CAMERA_ON_PRESET	114	
PRIVACY_HIDE_CURSOR	85	AUTO_ALARM_ON_PRESET	115	
PRIVACY_SAVE_PARAMETER	84	AUTO_ALARM_OFF_PRESET	116	
PRIVACY_LOAD_PARAMETER	83	PAN_REVERSE_PRESET	117	// swaps left/right
PRIVACY_INIT_PARAMETER	82	IR_MODE_ON_PRESET	118	// for keyboards without lamps button
PRIVACY_SET_CURSOR	81	IR_MODE_OFF_PRESET	119	
WASHWIPE_ON_PRESET	101	SOFTLIMIT_TOP_LEFT_PRESET	120	// Always lowest number
WASHWIPE_OFF_PRESET	102	SOFTLIMIT_BOTTOM_RIGHT_PRESET	121	
DIGITAL_ZOOM_ON_PRESET	103	NONDWELL_TOP_LEFT_PRESET	122	
DIGITAL_ZOOM_OFF_PRESET	104	NONDWELL_BOTTOM_RIGHT_PRESET	123	// Always highest number
SET_9600_BAUD_PRESET	105	AUTO_LOWLIGHT_ON_PRESET	124	
SET_1200_BAUD_PRESET	106	AUTO_LOWLIGHT_OFF_PRESET	125	
AUTO_IR_ON_PRESET	107	ADDRESS_CHANGE_PRESET	126	
AUTO_IR_OFF_PRESET	108	RESET_PRESETS_PRESET	127	



CAMERA_COMMAND_PRESET1	240	//not used in VCL version	PRIVACY_SET_CURSOR	35	
CAMERA_COMMAND_PRESET10	250		MULTI_ALARM_PRESET	50	// allow up to 12 alarms now.
Vicon			AUTO_IR_ON_PRESET	69	
PRIVACY_PRESET_START	35		AUTO_IR_OFF_PRESET	70	
PRIVACY_PRESET_END	49		MULTI_ALARM_ON_PRESET	71	
PRIVACY_SET_WHOLE	49		MULTI_ALARM_OFF_PRESET	72	
PRIVACY_CLEAR_WHOLE	48		AUTO_ALARM_ON_PRESET	73	
PRIVACY_UNCOVER_ALL	47		AUTO_ALARM_OFF_PRESET	74	
PRIVACY_REPLACE_ALL	46		AUTO_ALARM_GOTO_PRESET	50	
PRIVACY_SHOW_STYLE	45		BAUD_TOGGLE_PRESET	75	
PRIVACY_HIDE_STYLE	44		WASHER_PRESET	76	
PRIVACY_SET_STYLE	43		WIPER_CONT_PRESET	77	
PRIVACY_SET_CENTRAL	42		WIPER_INT5_PRESET	78	
PRIVACY_CLEAR_CENTRAL	41		WIPER_INT30_PRESET	79	
PRIVACY_SHOW_CURSOR	40		STORE_SEQUENCE_PRESET	80	
PRIVACY_HIDE_CURSOR	39		DELETE_SEQUENCE_PRESET	81	
PRIVACY_SAVE_PARAMETER	38		CLEAR_SEQUENCE_PRESET	82	
PRIVACY_LOAD_PARAMETER	37		SET_SEQUENCE_DWELL_PRESET	83	
PRIVACY_INIT_PARAMETER	36		START_SEQUENCE_PRESET	88	//defines for limit setting presets



SOFTLIMIT_TOP_LEFT_PRESET	90	// Always lowest number
SOFTLIMIT_BOTTOM_RIGHT_PRESET	91	
NONDWELL_TOP_LEFT_PRESET	92	
NONDWELL_BOTTOM_RIGHT_PRESET	93	// Always highest number
RESET_PRESETS_PRESET	94	
REVERSE_PAN_PRESET	95	
REVERSE_TILT_PRESET	96	
REVERSE_IMAGE_PRESET	97	
SET_ADDRESS_PRESET	99	
PRIVACY_SETUP_BYTE1	101	
PRIVACY_SETUP_BYTE2	102	
AUTOHOME_PRESET1_PRESET	103	
AUTOHOME_SEQUENCE_PRESET	104	
AUTOHOME_OFF_PRESET	105	
MOTOR_PARAMS_BYTE_1	106	
MOTOR_PARAMS_BYTE_2	107	
FIND_END_STOPS	108	



Free Manuals Download Website

<http://myh66.com>

<http://usermanuals.us>

<http://www.somanuals.com>

<http://www.4manuals.cc>

<http://www.manual-lib.com>

<http://www.404manual.com>

<http://www.luxmanual.com>

<http://aubethermostatmanual.com>

Golf course search by state

<http://golfingnear.com>

Email search by domain

<http://emailbydomain.com>

Auto manuals search

<http://auto.somanuals.com>

TV manuals search

<http://tv.somanuals.com>