

MMAC-Plus™ 9W111-08  
Eight Port WAN Router  
User's Guide

**CABLETRON**  
*SYSTEMS*  
The Complete Networking Solution™



## Notice

Cabletron Systems reserves the right to make changes in specifications and other information contained in this document without prior notice. The reader should in all cases consult Cabletron Systems to determine whether any such changes have been made.

The hardware, firmware, or software described in this manual is subject to change without notice.

IN NO EVENT SHALL CABLETRON SYSTEMS BE LIABLE FOR ANY INCIDENTAL, INDIRECT, SPECIAL, OR CONSEQUENTIAL DAMAGES WHATSOEVER (INCLUDING BUT NOT LIMITED TO LOST PROFITS) ARISING OUT OF OR RELATED TO THIS MANUAL OR THE INFORMATION CONTAINED IN IT, EVEN IF CABLETRON SYSTEMS HAS BEEN ADVISED OF, KNOWN, OR SHOULD HAVE KNOWN, THE POSSIBILITY OF SUCH DAMAGES.

© Copyright April 1995 by:

Cabletron Systems, Inc.  
35 Industrial Way  
Rochester, NH 03867-5005

All Rights Reserved  
Printed in the United States of America

Order Number: 9031375-02 April 1995

**MMAC-Plus** is a trademark of Cabletron Systems, Inc.  
**Cisco Systems** is a trademark of Cisco Systems, Inc.  
**CompuServe** is a registered trademark of CompuServe, Inc.

## FCC Notice

This device complies with Part 15 of the FCC rules. Operation is subject to the following two conditions: (1) this device may not cause harmful interference, and (2) this device must accept any interference received, including interference that may cause undesired operation.

**NOTE:** This equipment has been tested and found to comply with the limits for a Class A digital device, pursuant to Part 15 of the FCC rules. These limits are designed to provide reasonable protection against harmful interference when the equipment is operated in a commercial environment. This equipment uses, generates, and can radiate radio frequency energy and if not installed in accordance with the operator's manual, may cause harmful interference to radio communications. Operation of this equipment in a residential area is likely to cause interference in which case the user will be required to correct the interference at his own expense.

**WARNING:** Changes or modifications made to this device which are not expressly approved by the party responsible for compliance could void the user's authority to operate the equipment.

## VCCI Notice

This equipment is in the 1st Class Category (information equipment to be used in commercial and/or industrial areas) and conforms to the standards set by the Voluntary Control Council for Interference by Information Technology Equipment (VCCI) aimed at preventing radio interference in commercial and/or industrial areas.

Consequently, when used in a residential area or in an adjacent area thereto, radio interference may be caused to radios and TV receivers, etc.

Read the instructions for correct handling.

この装置は、第一種情報装置（商工業地域において使用されるべき情報装置）で商工業地域での電波障害防止を目的とした情報処理装置等電波障害自主規制協議会（VCCI）基準に適合しております。

従って、住宅地域またはその隣接した地域で使用すると、ラジオ、テレビジョン受信機等に受信障害を与えることがあります。

取扱説明書に従って正しい取り扱いをして下さい。

## DOC Notice

This digital apparatus does not exceed the Class A limits for radio noise emissions from digital apparatus set out in the Radio Interference Regulations of the Canadian Department of Communications.

Le présent appareil numérique n'émet pas de bruits radioélectriques dépassant les limites applicables aux appareils numériques de la class A prescrites dans le Règlement sur le brouillage radioélectrique édicté par le ministère des Communications du Canada.



## Chapter 1 Introduction

Features.....	1-1
Related Manuals.....	1-4
Getting Help .....	1-4

## Chapter 2 Installing the MMAC-Plus Module

The Reset Switch .....	2-3
Setting the FNB Switch.....	2-4
Local Management Console .....	2-4

## Chapter 3 Operation

Flexible Network Bus (FNB).....	3-2
System Management Buses .....	3-2
System Diagnostic Controller.....	3-2
DC/DC Converter .....	3-2
FNB Interface .....	3-3
CPU .....	3-3

## Chapter 4 LANVIEW LEDs

## Chapter 5 Specifications

Safety.....	5-1
Service.....	5-1
Physical.....	5-2
Dimensions .....	5-2
Weight.....	5-2
Environment .....	5-2





# Introduction

The 9W111-08 WAN Router module, shown in Figure 1-1, is a eight port Wide Area Net router. Up to eight front panel network connections can be made to this module and they can be routed to any other port and to any other MMAC-Plus module via the FNB bus.

## Features

### **Processor**

The 9W111-08 is equipped with an advanced IDT R4600 Fourth Generation 64 bit RISC microprocessor. This microprocessor provides a platform for all management functions within a scalable RISC-based architecture.

### **System Management**

The 9W111-08 provides an interface to the System Management Bus (SMB-1) for intermodule management.

### **Connectivity**

The 9W111-08 provides eight front panel High Density WAN ports.

### **Routing**

The 9W111-08 provides Routing between the front panel ports and/or to any other module in the chassis via FNB -1 or FNB -2 of the FNB bus. IEEE 802.1d Spanning Tree Protocol is supported in all bridging functions.

### **Management Information Base (MIB) Support**

All concentrator modules provide MIB support including the following:

- IETF FDDI MIB
- IETF MIB II

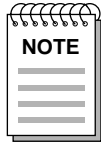

*For a complete list of supported MIBs, refer to the release notes provided in the module package.*

### **LANVIEW LEDs**

The 9W111-08 uses LANVIEW: the Cabletron Systems built-in visual diagnostic and status monitoring system. With LANVIEW LEDs, you can quickly identify the device, port, and physical layer status at a glance.

### **Hot Swapping**

The 9W111-08 can be installed or removed from the chassis while the MMAC-Plus is powered up without affecting the operation of the remaining modules in the chassis.

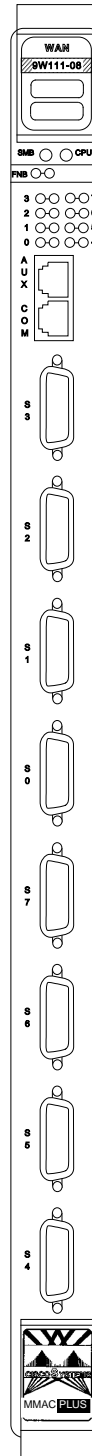

Figure 1-1. The 9W111-08 Module

## Related Manuals

The manuals listed below should be used to supplement the procedures and technical data contained in this manual.

**MMAC-Plus Installation Guide**

**MMAC-Plus Operations Guide**

**MMAC-Plus 9C300-1 Environmental Module User's Guide**

**MMAC-Plus 9C214-1 AC Power Supply User's Guide**

**Cisco Systems R4500 manuals - CRM-DOC or CRM-CDROM**

## Getting Help

If you need additional support with the MMAC-Plus, or if you have any questions, comments or suggestions concerning this manual, feel free to contact Cabletron Systems Technical Support:

By phone: (603) 332-9400

By CompuServe®: GO CTRON from any ! prompt

By Internet mail: support@ctron.com

By mail: Cabletron Systems, Inc.  
P.O. Box 5005  
Rochester, NH 03867-0505

# Installing the MMAC-Plus Module

The MMAC-Plus module may be installed into any of the 14 slots that are available. To install, follow the steps below:

1. Remove the blank panel, covering the slot that the module is being mounted in. All other slots must be covered, if modules are not being installed, to ensure proper airflow and cooling.
2. Carefully remove the module from the shipping box. (Save the box and packing materials in the event the module must be reshipped.)
3. Attach one end of the ESD wrist strap packaged with the MMAC-Plus chassis to your wrist. Plug the other end into the ESD Wrist Strap Grounding receptacle in the lower right corner of the MMAC-Plus Chassis shown in Figure 1.
4. Remove the module from the plastic bag. Observe all precautions to prevent damage from Electrostatic Discharge (ESD).
5. Carefully examine the module, checking for damage. If any damage exists, DO NOT install the module. Contact Cabletron Systems Technical Support immediately.
6. Before installing the MMAC-Plus cards into the chassis, ensure that the bottom and top plastic tabs are unlocked. Slide the card into an available slot and ensure that the circuit card is between the card guides, as shown in Figure 1. Check both the upper and lower tracks. Take care that the module slides in straight and engages the backplane connectors properly. Lock down the top and bottom plastic tabs at the same time, applying even pressure.

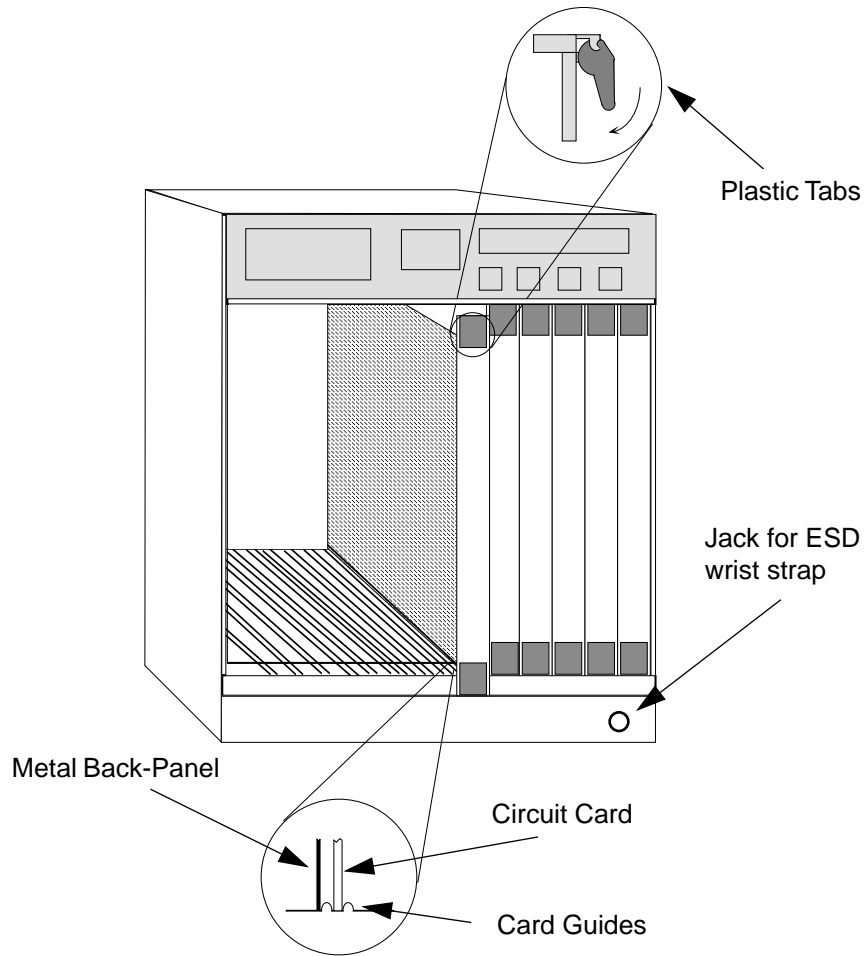

**Warning:**  
Ensure that the circuit card is between the card guides.  
Lock down the top and bottom plastic tabs  
at the same time, applying even pressure.

Figure 2-1. Installing the MMAC-Plus Module

## The Reset Switch

The Reset switch is located on the front panel, under the top plastic tab, as shown in Figure 2-2. It serves two functions:

- Pressing the Reset switch twice within three seconds causes the processor to reset.
- Pressing and holding the switch on for three or more seconds causes the module to shutdown. Pressing and holding again for three seconds restarts the module.

SNMP management may be used to disable this switch to enhance module security.

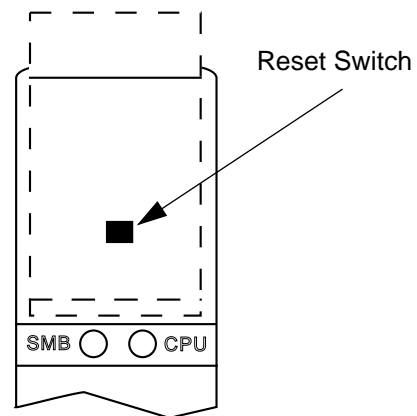

Figure 2-2. The Reset Switch

## Setting the FNB Switch

The 9W111-08 module can attach to either FNB-1 or FNB-2. Figure 2-3 shows the location of the FNB switch, SW201. When this switch is up (toward the top of the module) the 9W111-08 attaches to FNB-2. When down, it attaches to FNB-1.

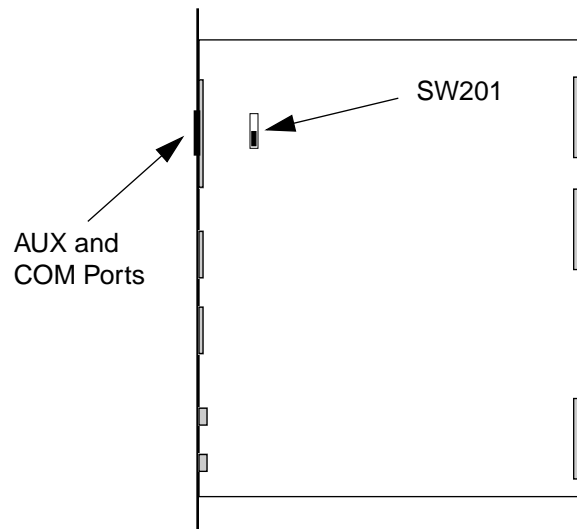

Figure 2-3. Location of the FNB Switch

## Local Management Console

Local Management is accessed by attaching a management console at the RJ-45 COM port of the 9W111-08. The console connection supports a Digital Equipment Corporation VT 320™ terminal or PC emulation of one of these terminals.

Table 2-1 lists the setup requirements for the local management console. If your terminal is a Digital Equipment Corporation VT 320™ terminal, press **F3** to access the Setup Directory. If you have a terminal emulation of the Digital Equipment terminals, refer to your equipment user manual for setup procedures.



Table 2-1. Terminal Setup Requirements

<b>Menu</b>	<b>Function</b>	<b>Selection</b>
Display Setup:	Columns	80 Columns
	Controls	Interpret Controls
	Auto Wrap	No Auto Wrap
	Text Cursor	Cursor
General Setup:	Mode	7 Bit Control
	Cursor Keys	Normal Cursor Keys
Communications Setup:	Transmit	Transmit = 9600
	Receive	Receive = Transmit
	XOFF	any option
	Bits, Parity	8 Bits, No Parity
	Stop Bit	1 Stop Bit
	Local Echo	No Local Echo
Port		EIA Port, Data Leads Only
		DEC-423, Data Leads only
	Transmit	any option
	Auto Answerback	No Auto Answerback
Keyboard Setup:	Auto Repeat	any option
	Keyclick	any option
	Margin Bell	Margin Bell
	Warning Bell	Warning Bell
	Auto Answerback	No Auto Answerback

An RJ-45 connector provides a COM interface to the management terminal. Figure 2-4 shows the pinouts.

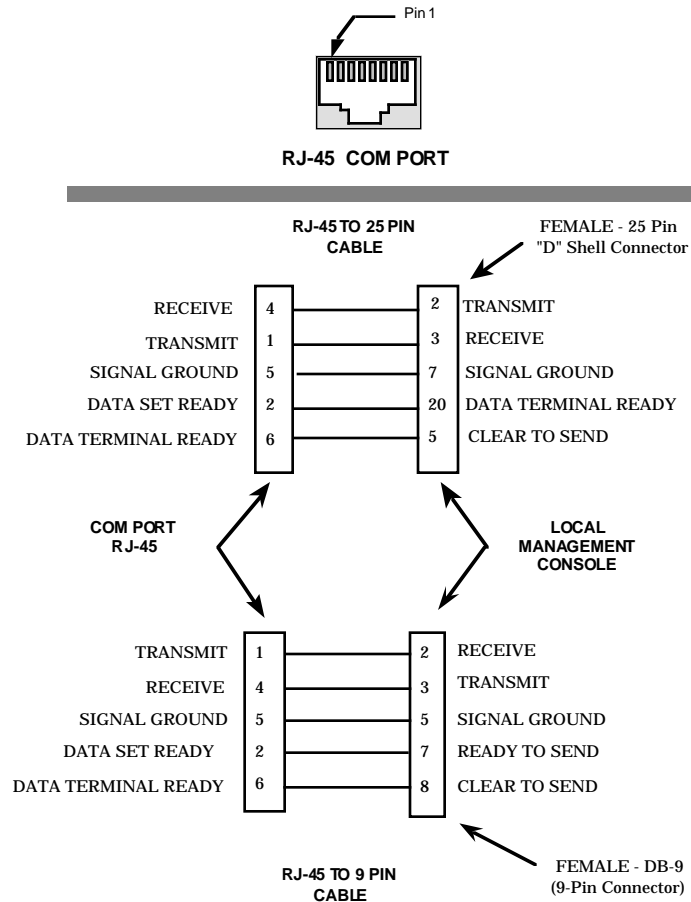

Figure 2-4. Console Cable Pinouts

Connect the console to the module as follows:

1. Attach the male RJ-45 connector to the COM port of the 9W111-08.
2. Attach the female end (25-pin or 9-pin, as applicable) to the terminal.

Refer to the Cisco Systems documentation for the R4500 router, for information on configuring this module.

# Operation

The 9W111-08 WAN Router module is a eight port Wide Area Net router. Up to eight front panel network connections can be made to this module and they can be routed to any other port and to any other MMAC-Plus module via the FNB bus.

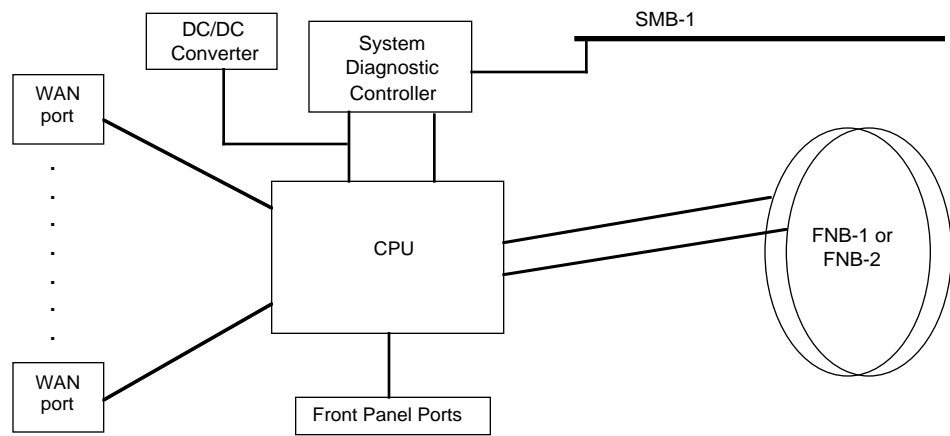

Figure 3-1. 9W111-08 Block Diagram

## Flexible Network Bus (FNB)

The FNB consists of two dual FDDI networks, the FNB-1 and FNB-2, providing up to 400 Mbps of data bandwidth. These FDDI networks are 100% ANSI FDDI-compliant, supporting SMT (version 7.3), MAC, PHY, and PMD standards. This allows the FNB to traverse multiple MMAC-Plus hubs, or connect to any ANSI FDDI-compliant device, through standard A/B port connections.

## System Management Buses

The SMB-1 is a 1 Mbps management bus located within the MMAC-Plus. This bus is utilized by all diagnostic controllers in the system. These include connectivity modules, power supply modules, and the environmental module. The SMB-1 transports inter-chassis information between system components, such as power and environmental information, as well as diagnostic messages. Periodic loop-back tests are performed by all modules that share this bus to ensure the validity of SMB-1.

## System Diagnostic Controller

This diagnostic controller is composed of a Z-80 microprocessor and its supporting logic. The diagnostic controller is designed to control the power-up sequencing of modules, monitor the 9W111-08 input and output power parameters, keep watch over the main host processor, as well as monitor the temperature and control the SMB LANVIEW diagnostic LED. The information gathered by the diagnostic controller is available to the network manager via local/remote management and the LCD located on the Environmental Module. The 9W111-08 have been designed so that in the event of a diagnostic controller fault, the modules will continue to function.

## DC/DC Converter

The DC/DC converter converts the 48 VDC on the system power bus to the necessary operating voltages for its host network services module. The diagnostic controller controls the operation of the DC/DC converter.

## **FNB Interface**

MMAC-Plus modules are designed with one of two attachment policies. One allows dual attachment of a module to either FNB-1 or FNB-2; the second allows dual attachment to both FNB-1 and FNB-2. The 9W111-08 has one dual attachment to the FNB backplane, connecting to either FNB-1 or FNB-2. The module can insert into the FNB or bypass it. These flexible configuration options make the MMAC-Plus ideal for networks designed to Bridge/Route multiple lower speed LANs to FDDI and/or networks designed using an FDDI collapsed backbone.

## **CPU**

The CPU provides the SNMP protocol stacks, as well as support for industry standard MIBs.



# LANVIEW LEDs

The front panel LANVIEW LEDs, shown in Figure 4-1, indicate the status of the module and may be used as an aid in troubleshooting.

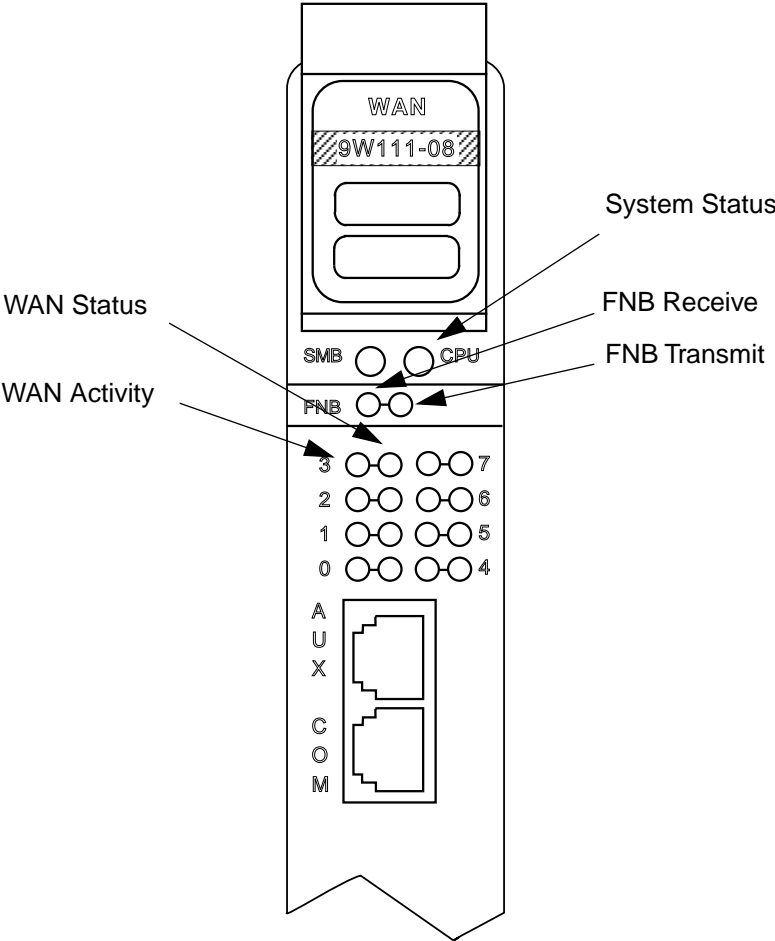

Figure 4-1. LANVIEW LEDs

The functions of the System Management Bus (SMB) and CPU LEDs are listed in Table 4-1.

Table 4-1. SMB and CPU LEDs

LED Color	State	Description
Green	Functional	Fully operational.
Yellow (Flashing)	Crippled	Conditional WAN fault *.
Yellow	Booting	Booting.
Red	Reset	Normal power-up reset.
Red (Flashing)	Failed	FDDI Fault (FNB is down).
Off	Power off	Module powered off.

\* At least one WAN port in both groups 0-3 and 4-7 are down.

The function of the FNB Receive LED is listed in Table 4-2.

Table 4-2. FNB Receive LED

LED Color	State
Yellow (Flashing)	Activity (Flashing rate indicates rate of activity).
Off	No activity

The function of the FNB Transmit LED is listed in Table 4-3.

Table 4-3. FNB Transmit LED

LED Color	State
Green (Flashing)	Activity (Flashing rate indicates rate of activity).
Off	No activity



The functions of the WAN Status LEDs are listed in Table 4-4.

Table 4-4. WAN Status LEDs

LED Color	State
Green	Connection, Transmit clock active, Receive clock active, No Loop Mode detected
Yellow	Connection, Transmit clock active, Receive clock active, Loop Mode detected
Red	Connection, No Transmit clock, No Receive clock
Off	No Connection

The function of the WAN Activity LEDs are listed in Table 4-5.

Table 4-5. WAN Activity LEDs

LED Color	State
Green	Activity
Off	No activity



# Specifications

## Safety



*It is the responsibility of the person who sells the system to which the module will be a part to ensure that the total system meets allowed limits of conducted and radiated emissions.*

This equipment meets the following safety requirements:

- UL 1950
- CSA C22.2 No. 950
- EN 60950
- IEC 950
- EMI Requirements of FCC Part 15 Class A
- EN 55022 Class A
- VCCI Class I
- EMC the following requirements:

EN 50082-1  
IEC 801-2 ESD  
IEC 801-3 Radiated susceptibility  
IEC 801-4 EFT

## Service

MTBF (MHBK-217E): >200,000 hrs.

MTTR: <0.5 hr.

## Physical

### Dimensions

35.0 D x 44.0 H x 3.0 W centimeters  
(13.8 D x 17.4 H x 1.2 W inches)

### Weight

Unit:	1.36 kg. (3 lb)
Shipping:	1.81 kg. (4 lb)

### Environment

Operating Temperature	5 to 40° C
Storage Temperature	-30 to 90° C
Relative Humidity	5% to 95% non-condensing

## Free Manuals Download Website

<http://myh66.com>

<http://usermanuals.us>

<http://www.somanuals.com>

<http://www.4manuals.cc>

<http://www.manual-lib.com>

<http://www.404manual.com>

<http://www.luxmanual.com>

<http://aubethermostatmanual.com>

Golf course search by state

<http://golfingnear.com>

Email search by domain

<http://emailbydomain.com>

Auto manuals search

<http://auto.somanuals.com>

TV manuals search

<http://tv.somanuals.com>