

# MSC-2769-SLD CAMERON

## OWNER'S MANUAL

### ASSEMBLY INSTRUCTION, CARE, MAINTENANCE & USER'S GUIDE

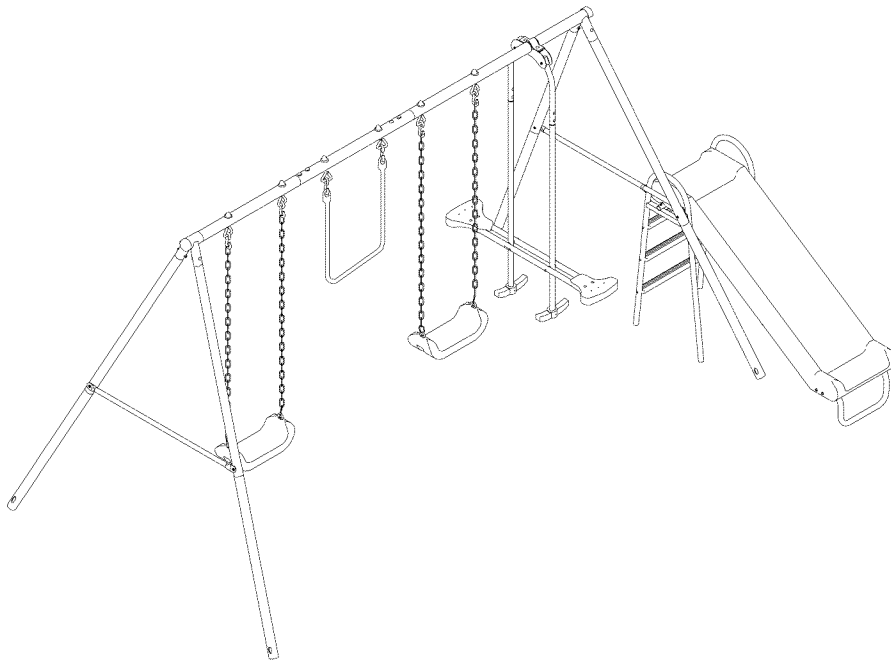

**CAUTION** This unit is designed to be used safely by up to 6 children between the age of 2 to 8, with a maximum weight of 100 pounds(45.4kgs) each, simultaneously, not to exceed a combined weight of 600 pounds(272.72kgs).



## WARNING

Please read this instruction manual before you start with the assembly or use this swing set. You must follow all safety instructions while using this equipment; be absolutely sure that the surface, on which this swing set is set up on, is properly surfaced with fine sand, wood chips or double shredded bark mulch. Do not use this swing set on hard pack soil, concrete or any kind of hard surface. Read all cautionary statement on page 1 - page 4, before using this equipment. Save this instruction manual for future reference.

**CUSTOMER SERVICE:  
DO NOT RETURN TO THE STORE ,  
PLEASE CALL  
1-866-884-0535**

**Monday-Friday, 8:00AM-5:00PM Eastern Time  
[www.Sportspowercustomerservice.com](http://www.Sportspowercustomerservice.com)**

**Sportspower Ltd  
Flat M, 3/Floor, Kaiser Estate Phase 3, 11 Hok Yuen Street,  
Hungghom, Kowloon, HongKong**

## USER'S GUIDE



**WARNING**

**CAUTION!**

### READ BEFORE USING THIS EQUIPMENT

## GENERAL INSTRUCTION

- Read this manual and follow all instructions before using and assembling this unit.
- Observing the following statements and warnings reduces the likelihood of serious fatal injury.
- Recommending on-site adult supervision for children of all ages at all times.
- This unit is designed to be used safely by up to 6 children between the age of 2 to 8, with a maximum weight of 100 pounds (45.4 kgs) each, simultaneously, not to exceed a combined weight of 600 pounds (272.72 kgs).

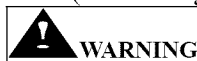

**WARNING** Lawn swings is designed for use by children over two years of age. Use by children under the age of two can result in entrapment between the seat and back areas. NEVER place children in rearward facing position or with legs between the seat and backrest because the child's body may pass through the opening causing entrapment of the child's head.



**WARNING** This unit must be assembled and disassembled by a capable adult person. We suggest that you get someone to help.



**WARNING** Children must not use the equipment until properly assembled and anchored.



**WARNING** Always locate the swing set on level ground!



**WARNING** Do not allow swing set near any obstruction or sharp object ! Place gym set on level ground, not less than 6ft (1.8m) from any structures or obstacles such as fence, garage, shed house, overhanging branches, laundry line, electrical wires.



**WARNING** If the seats of swing, glide or slide are wet, do not use this equipment.



**WARNING** If any bolts & nuts are missing, do not use this equipment!



**WARNING** A capable adult should supervise the use of this equipment at all times. Do not allow reckless playing, such as jumping off swing, slide, or Glide ride.

- Provide proper surface material cover for this equipment prior to using this equipment. See page 3 of this manual for more information.



**WARNING** Do not allow more than one child to play on the swing, trapeze bar or slide at any one time. Children shall take turns using the slide.



**WARNING** If the child has any physical condition that may affect his/her ability to use this equipment, one shall consult a physician, before allowing the child to use this equipment.



**WARNING** Do not allow child over the weight limit to use this equipment. Adults should never ride on any of the rides, swing, trapeze or slide.



**WARNING** Do not allow child to stand on the swing seats or glide ride.



**WARNING** Instruct children not to walk too close in front of, behind, or between moving items. Instruct children to keep a safe distance away to avoid being struck by items in play .



**WARNING** Instruct children not to twist swing chains or ropes or loop them over the top support bar since this may reduce the strength of the chain or rope.



**WARNING** Instruct children to avoid swinging empty play items.





**WARNING** Teach children to sit in the center of the swing play items, with their full weight in the seats.





**WARNING** Instruct children not to use the equipment in any manner other than intended.

 **WARNING** Instruct children not to get off equipment while it is in motion. Do not allow children to jump from moving play items.

 **WARNING** Parent to dress children appropriately while on and around this equipment (Examples would include the use of well fitting shoes and the avoidance of ponchos, scarves, jewelry and other loose fitting clothing that is potentially hazardous while using equipment).

 **WARNING** Do not allow children to climb or play on equipment when it is wet.

 **WARNING** Do not stand on the lawn swing when using this ride. One child per seat only!

 **WARNING** Check the openings between rollers and sliding surfaces of roller slides for foreign materials that could be potentially hazardous to users.

- Please verify that suspended climbing ropes, chain, or cable are secured at both ends, and verify that suspended climbing ropes, chain, or cable cannot be looped back on itself.

 **WARNING** Instruct children not to attach items to the playground equipment that are not specifically designed for use with the equipment such as but not limited to jump ropes, clothesline, pet leashes, cables and chain as they may cause a strangulation hazard.

- It is recommended that the gym set be placed in concrete. Be certain that all anchoring devices ( including concrete ) are placed below the level of the playing surface or below ground level to prevent tripping .

 **WARNING** Do not allow children to lean to the side when riding on other rides, structural members on collide with other playmates.

 **WARNING** Do not install home playground equipment over concrete, asphalt, packed earth, grass, carpet, or any other hard surface. A fall onto a hard surface can result in serious injury to the equipment user.

 **WARNING** Do anchor all gyms.

 **WARNING** If the swing set is set up on grounds with sandy soil condition, it must be anchored with concrete footing (Concrete not included).

### **OPERATING INSTRUCTIONS (WARNING THE BUYER)**

- Observing the following statements and warnings reduces the likelihood of serious or fatal injury.
- This unit is designed to be used safely by up to 6 children between the age of 2 to 8, with a maximum weight of 100 pounds (45.4 kgs) each, simultaneously, not to exceed a combined weight of 600 pounds (272.7 kgs).
- On-site adult supervision for children of all ages is recommended..

 **WARNING** Instruct children not to walk close to, in front of, behind, or between moving items.

 **WARNING** Instruct children not to twist swing chains or ropes or loop them over the top support bar since this may reduce the strength of the chain or rope.

 **WARNING** Instruct children to avoid swinging empty seats.

 **WARNING** Teach children to sit in the center of the swings with their full weight on the seats,

 **WARNING** Instruct children not to use the equipment in a manner other than intended,

 **WARNING** Instruct children not to get off equipment while it is in motion.

 **WARNING** Adult should dress children appropriately (examples would include the use of well-fitting shoes and the avoidance of ponchos, scarfs, and other loose-fitting shoes and other loose-fitting clothing that is potentially hazardous while using equipment).

 **WARNING** Instruct children not to climb when the equipment is wet.

 **WARNING** Please verify that suspended climbing ropes, chain, or cable are secured at both ends, and that suspended climbing ropes, chain, or cable cannot be looped back on itself.



**WARNING** Instruct children not to attach items to the playground equipment that are not specifically designed for use with the equipment, such as, but not limited to, jump ropes, clothesline, pet leashes, cables and chain as they may cause a strangulation hazard.



**WARNING:**

Lawn swings, if applicable, are designed for use by children two years of age and older. The use by children under the age of two can result in entrapment between the seat and back rest because the child's body may pass through the opening, causing entrapment of the child's head. Such entrapment may result in strangulation. **NEVER** place children in a rearward facing position or with legs between the seat and backrest.



**WARNING** Instruct children not to go down slide head first.

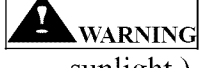

**WARNING** Check slide bed for extreme heat before letting children use slide ( When exposed to direct sunlight )



**WARNING** Do not allow children to climb on swing from structural members (Legs, top bar and chin bar). These are structural components only and NOT play features.

- If there is any cracked or damaged parts, do not use this equipment; call the 1-866-884-0535 number for replacement part.
- Please save this instruction manual for future reference and review each season .
- Plastic components should be replaced every three years.

### TIGHTENING NUTS & BOLTS

- At the start of assembling, do not tighten bolt/nut all the way, so to allow some possible adjustment, for ease of installation.
- After all major components are assembled, go back over all bolts and nuts and properly tighten all of them before using this product.

### CARE & MAINTENACE INSTRUCTION

- Check all nuts and bolts twice monthly during the usage season for tightness and tighten as required. It is particularly important that this procedure be followed at the beginning of each season.
- Oil all metallic moving parts monthly during the usage period.
- Sand rusted areas on metal tubing and repaint using a nonlead-based paint meeting the requirements of Title 16 CFR Part 1303.
- Check swing seats, ropes, cables and chains monthly during usage season for evidence of deterioration. Replacement should be made in accordance with manufacturer's instructions.
- Check all coverings for bolts and sharp edges twice monthly during usage season to be certain they are in place. Replace when necessary. It is especially important to do this at the beginning of each new season.
- Remove plastic swing seats slide and take indoors or do not use when temperature drops below 32 degrees F (0 degrees C).

### Disposal Instructions

- ✧ Please use with care to disassemble the unit, when it is no longer in operational condition. Wear heavy duty working gloves!
- ✧ Consumer may wish to recycle the steel tubing, please take the frame to your local recycling center.
- ✧ Be sure to completely disassemble the whole swing and slide sets, before disposal.
- ✧ Do not leave partially disassembled equipment in area where accessible by children.
- ✧ All plastic parts could be recycled, take it to your local recycling center.
- ✧ All rusted parts, bolts shall be properly disposed of in trash bin. Do not reuse.
- ✧ Do not let children play with any disassembled parts destined for disposal, such as chain, slide, tubings, bolts, nuts, screws!

# IMPORTANT

## CONSUMER INFORMATION SHEET

The Consumer Product Safety Commission estimates that about 100,000 playground equipment-related injuries resulting from falls to the ground equipment treated annually in U.S. hospital emergency rooms. Injuries involving this hazard pattern tend to be among the most serious of all playground injuries, And have the potential to be fatal, particularly when the injury is to the head.

The surface under and around playground equipment can be a major factor in determining the injury-causing potential of a fall. It is self evident that a fall onto a shock absorbing surface is less likely to cause a serious injury than a fall onto a hard surface. Playground equipment should never be placed on hard surfaces such as concrete or asphalt and while grass may appear to be acceptable it may quickly turn to hard packed earth in areas of high traffic. Shredded bark mulch, wood chips fine sand or fine gravel are considered to be acceptable shock absorbing surface when installed and maintained at a sufficient depth under and around playground equipment.

Table below lists the maximum height from which a child would not be expected to sustain a life-threatening head injury in a fall onto four different loose-fill surfacing materials if they are installed and maintained at depths of 6, 9, and 12 in.

<b>FALL HEIGHT IN FEET FROM WHICH A LIFE THREATENING HEAD INJURY WOULD NOT BE EXPECTED</b>			
<b>TYPE OF MATERIAL</b>	<b>6INCH DEPTH</b>	<b>9INCH DEPTH</b>	<b>12INCH DEPTH</b>
<b>Double shredded bark mulch</b>	<b>6</b>	<b>10</b>	<b>11</b>
<b>Wood Chips</b>	<b>6</b>	<b>7</b>	<b>12</b>
<b>Fine Sand</b>	<b>5</b>	<b>5</b>	<b>9</b>
<b>Fine Gravel</b>	<b>6</b>	<b>7</b>	<b>10</b>

However, it should be recognized that all injuries due to falls can not be prevented no matter what surfacing material is used.

We recommend that a shock absorbing material should extend a minimum of 6ft in all directions from the perimeter of stationary equipment such as climbers and slides. However, Because children may deliberately jump from a moving swing. The shock absorbing material should extend in the front and rear of a swing a minimum distance of 2 times the height of the pivot point measured from a point directly beneath the pivot on the supporting structure.

This information is intended to assist in comparing the relative shock-absorbing properties of various materials. No particular material is recommended over another. However, Each material is only effective when properly maintained. Materials should be checked periodically and replenished to maintain correct depth as determined necessary for your equipment. The choice of a material depends on the type and height of the playground equipment. The availability of the material in your area and its cost.

Note: The maximum fall height for this product is 6 feet. The minimum ground clearance between the bottom of the suspended plays and the playing or ground service must be 8 inches.

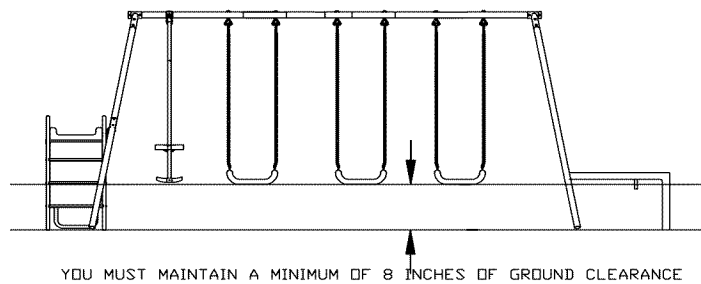

This information has been extracted from the CPSC publication on "Playground Safety". You can obtain more information by sending a postcard to the: Office of public Affairs, U.S. Consumer Product Safety Commission, Washington, D.C. 20207.

# HARDWARE (ACTUAL SIZE BUT FOR REFERENCE ONLY )

## Hardware used for main frame assembly



Ⓑ1 BOLT 5/16"x63 4PCS

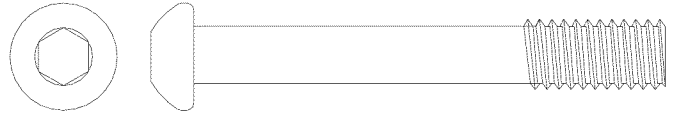

Ⓑ2 BOLT 5/16"x63 12PCS

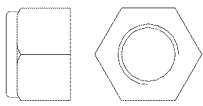

Ⓑ3 NYLON NUT 5/16"  
16PCS

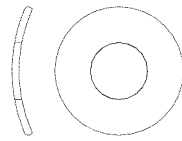

Ⓑ4 ARC WASHER  
28PCS

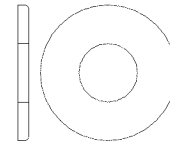

Ⓑ5 LARGE WASHER  
4PCS

## Hardware used for swing seats assembly

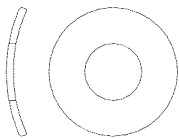

ⓙ2 ARC WASHER  
4PCS

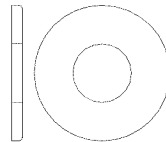

ⓙ5 LARGE WASHER  
4PCS

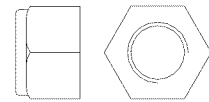

ⓙ6 NYLON NUT 5/16"  
8PCS

## Hardware used for trapeze assembly



Ⓢ5 ARC WASHER  
2PCS



Ⓢ6 NYLON NUT  
2PCS

## Bracket used for glide ride assembly

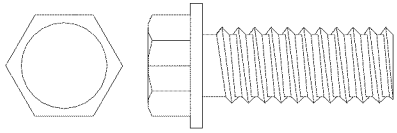

N3 BOLT 5/16"x25 2PCS

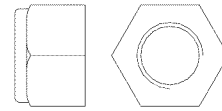

N7 NYLON NUT 5/16"  
2PCS

## Hardware used for glide ride assembly

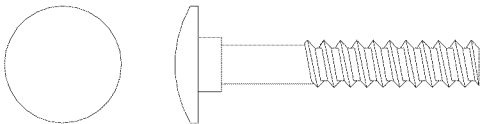

N1 BOLT 1/4"x34 4PCS

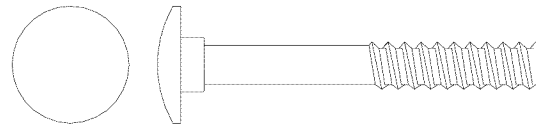

N2 BOLT 1/4"x48 2PCS

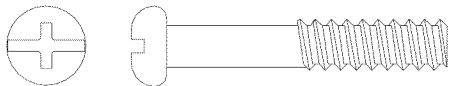

N4 BOLT 1/4"x34 4PCS

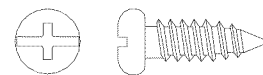

N5 SCREW Ø5.5x16 4PCS

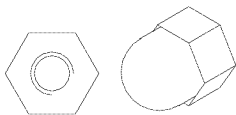

N8 NYLON NUT 1/4"  
10PCS

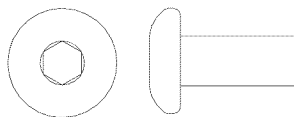

N9 CAP BOLT 1/4"x14 2PCS



N10 SPRING WASHER  
10PCS

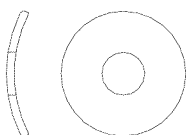

N11 ARC WASHER  
4PCS

## Hardware used for slide assembly



① BOLT 1/4"x34 14PCS



② BOLT 1/4"x59 2PCS

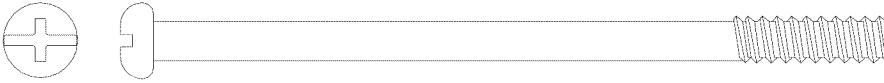

③ BOLT 1/4"x96 2PCS

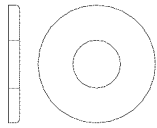

④ SMALL WASHER 6PCS

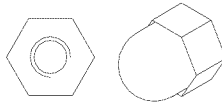

⑤ NYLON NUT 1/4" 14PCS



⑥ SMALL ARC WASHER 4PCS

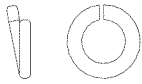

⑦ SPRING WASHER 12PCS



# Tools needed for assembly



Special Socket Wrench  
(included)

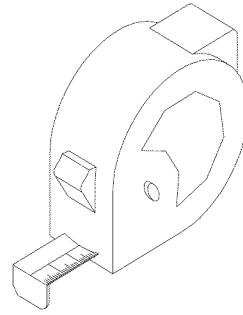

Tape Measure  
Not included

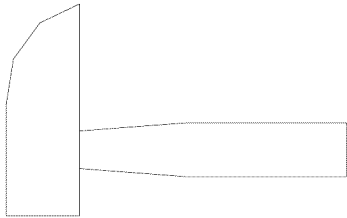

Hammer  
(If you intend to install  
anchor, this is needed.)  
Not included

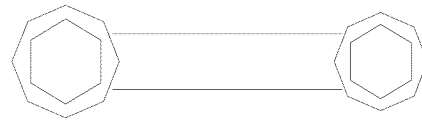

wrench  
(included)

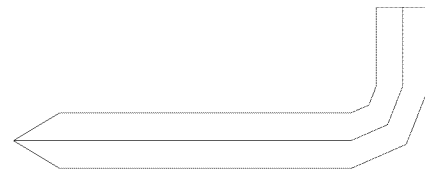

Big Allen Wrench  
(included)

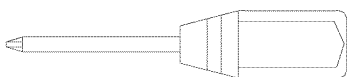



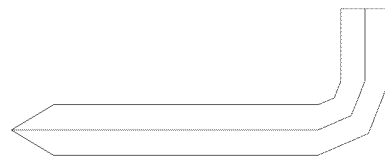



Flat Head Philips  
Head Screwdriver  
Not included









Small Allen Wrench  
(included)





## Parts used for main frame assembly.

A1		LEFT TOP BAR	1 PC
A2		RIGHT TOP BAR	1 PC
A3		MIDDLE TOP BAR	1 PC
A4		TOP SECTION LEG	4 PCS
A5		BOTTOM SECTION LEG	4 PCS
A6		CROSS BAR	2 PCS
C2		END CAP (PREASSEMBLED)	2 PCS





## Hardware used for main frame assembly

B1		BOLT 5/16"*63	4 PCS
B2		BOLT 5/16"*63	12 PCS
B3		NYLON NUT 5/16"	16 PCS
B4		ARC WASHER	28 PCS
B5		WASHER	4 PCS
C1		PLASTIC CAP	20 PCS



## Parts used for swing seats assembly

J1		PVC COVERED CHAIN (PREASSEMBLED)	4 PCS
J3		EYE BOLT WITH ATTACHMENT BOLT (PREASSEMBLED)	4 PCS
J4		EYE BOLT (PREASSEMBLED)	4 PCS
K1		SWING SEAT	2 PCS
K2		RUBBER COVER (PREASSEMBLED)	4 PCS



## Hardware used for swing seats assembly

J2		ARC WASHER	4 PCS
J5		LARGE WASHER	4 PCS
J6		NYLON NUT 5/16"	8 PCS
K3		PLASTIC CAP	8 PCS









## Parts used for trapeze assembly

P1		TRAPEZE TUBE	1 PC
S1		EYE BOLT WITH ATTACHMENT BOLT	2 PCS
T3		RUBBER CAP (PREASSEMBLED)	2 PCS

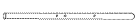



## Hardware used for trapeze assembly

S5		ARC WASHER 5/16"	2 PCS
S6		NYLON NUT 5/16"	2 PCS
T4		PLASTIC CAP	2 PCS









## Parts used for glide ride assembly

L1		TOP SECTION HANGER	2 PCS
L2		BOTTOM SECTION HANGER	2 PCS
L3		GLIDE SEAT SUPPORT	2 PCS
M1		TUBE CAP (PREASSEMBLED)	2 PCS
M2		SMALL NYLON BEARING (PREASSEMBLED)	4 PCS
M3		LARGE NYLON BEARING (PREASSEMBLED)	4 PCS
M4		GLIDE SEAT	2 PCS
M5		FOOTREST	2 PCS







## Brackets used for glide ride assembly

L4		BRACKET CLAMP	1 PC
L5		BRACKET	1 PC
L6		REINFORCING STEEL SPACER	2 PCS
N3		BOLT 5/16"*25	2 PCS
N7		NYLON NUT 5/16"	2 PCS

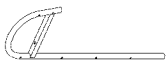



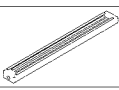





## Hardware used for glide ride assembly

N1		BOLT 1/4"*34	4 PCS
N2		BOLT 1/4"*48	2 PCS
N4		BOLT 1/4"*34	4 PCS
N5		SCREW $\varnothing$ 5.5*16	4 PCS
N6		J-BOLT	2 PCS
N8		NYLON NUT 1/4"	10 PCS
N9		CAP BOLT 1/4"*14	2 PCS
N10		SMALL WASHER	10 PCS

## Parts used for slide assembly

X1		SLIDE SUPPORT (W/ATTACHMENT HOLE TO LEG)	1 PC
X2		SLIDE SUPPORT	1 PC
X3		SLIDE LEG TUBE	2 PCS
X4		SLIDE TOP SUPPORT BAR	1 PC
X5		SLIDE FRONT SUPPORT	1 PC
X6		SLIDE LADDER STEPS	3 PCS
Y2		SLIDE	1 PC
Y3		CAP FOR X4 (PREASSEMBLED)	2 PCS

## Hardware used for slide assembly

X7		BENDED CONNECTOR	2 PCS
X8		SLIDE ATTACHMENT BRACKET	2 PCS
Y1		SHORT PLASTIC TUBE	2 PCS
Z1		BOLT 1/4" * 34	14 PCS
Z2		BOLT 1/4" * 59	2 PCS
Z3		BOLT 1/4" * 96	2 PCS
Z4		SMALL WASHER	6 PCS
Z5		NYLON NUT 1/4"	14 PCS
Z6		SMALL ARC WASHER	4 PCS
Z7		SPRING WASHER	12 PCS

# ASSEMBLY INSTRUCTION

- ◇ Place the playground equipment on level ground, not less than 6 ft (1.8 m) from any structure or obstruction such as a fence, garage, house, overhanging branches, laundry lines, or electrical wires.
- ◇ Do not install the playground equipment over concrete, asphalt, packed earth, or any other hard surface. A fall onto a hard surface can result in serious injury to the user.

## TIGHTENING NUTS & BOLTS

- \* Do not over-tighten the nuts and bolts when you are assembling your playground equipment. This will allow for some possible adjustments and ease of installation.
- \* Once you have finished the assembly of the playground assembly, go back over all of the nuts and bolts and properly tighten all of them before using the playground equipment.

## Main frame layout

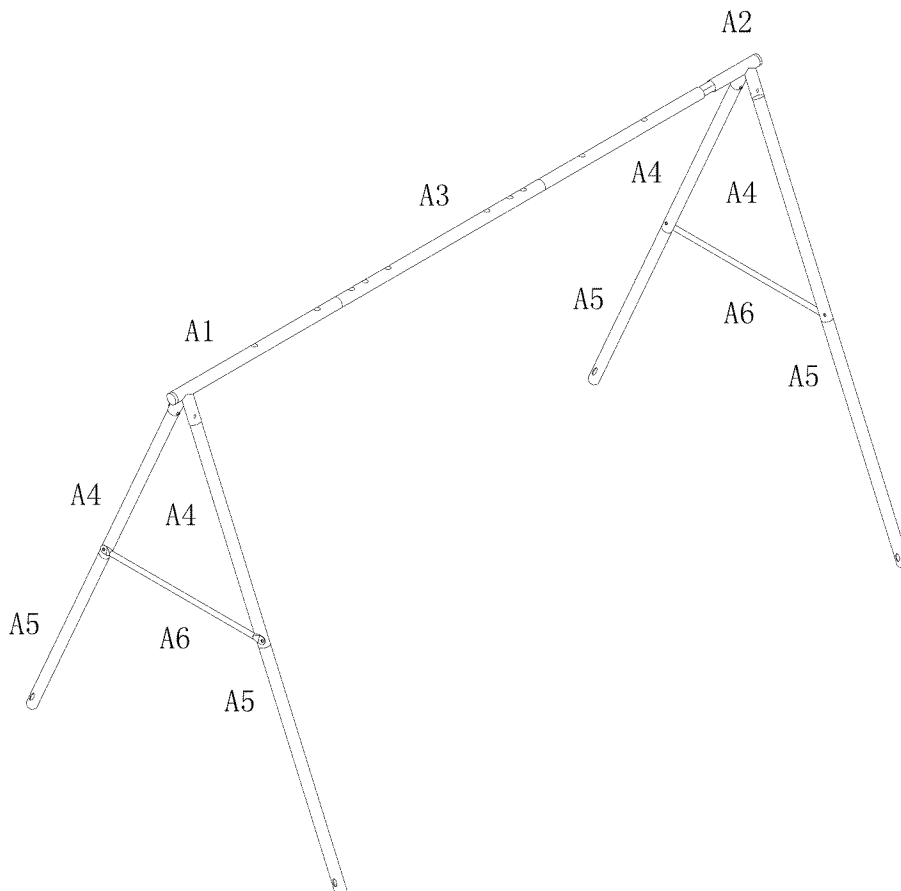

## Step 1

- Insert A1 into A3, secure with B1, B3, B4 and C1.
- Insert A3 into the other end of A2, secure with B1, B3, B4 and C1

Note: Please make sure that concave holes face down and round holes face up.

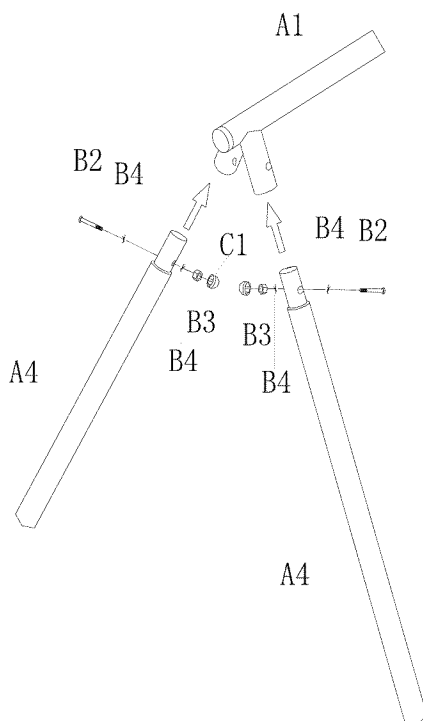
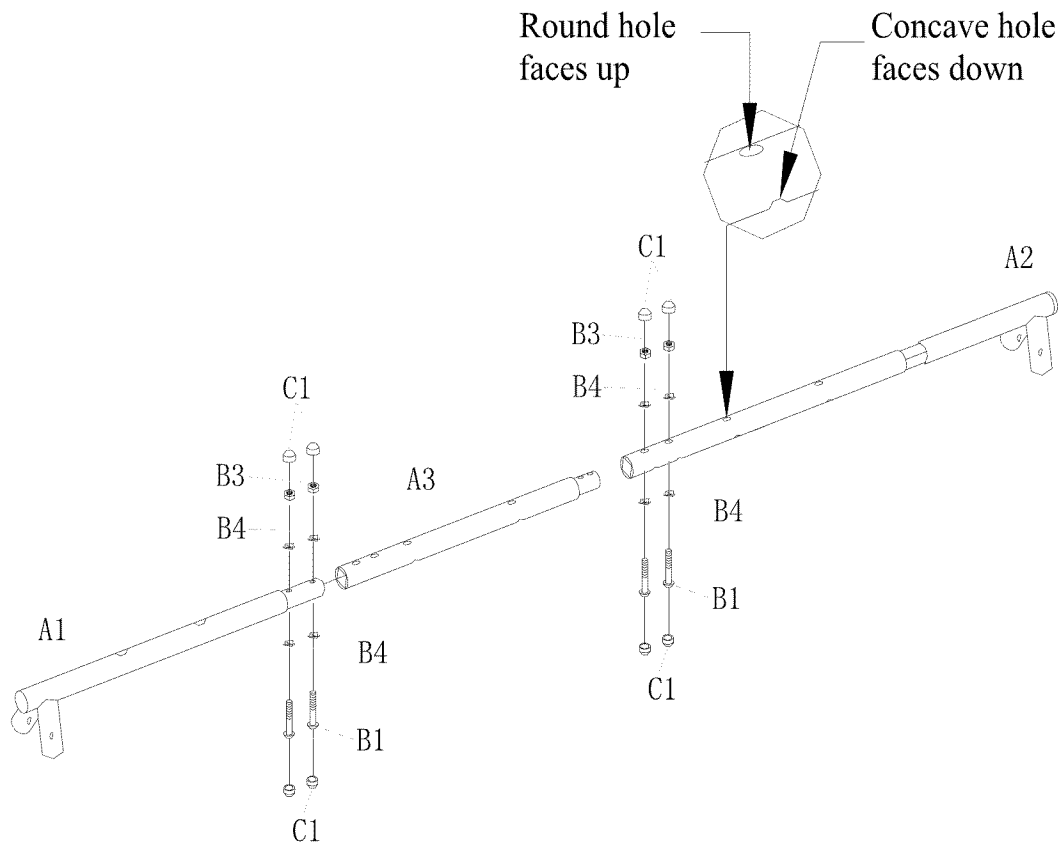

## Step 2

- Insert small end of A4 into the socket at the end of A1.
- Align the holes and secure using B2, B4, B3 and C1.
- Insert small end of A4 into the socket at the end of A2.
- Align the holes and secure using B2, B4, B3 and C1.



### Step 3

- Insert A5 into A4 and align the holes.
- Attach A6 to the left outer side of A5.
- Secure all three pieces using B2, B4, B5, B3 and C1.
- Repeat above the right side.

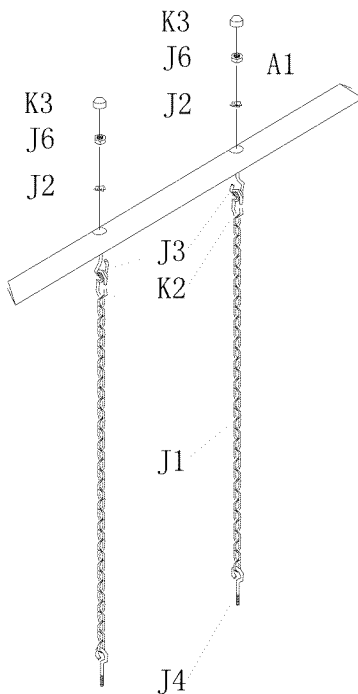
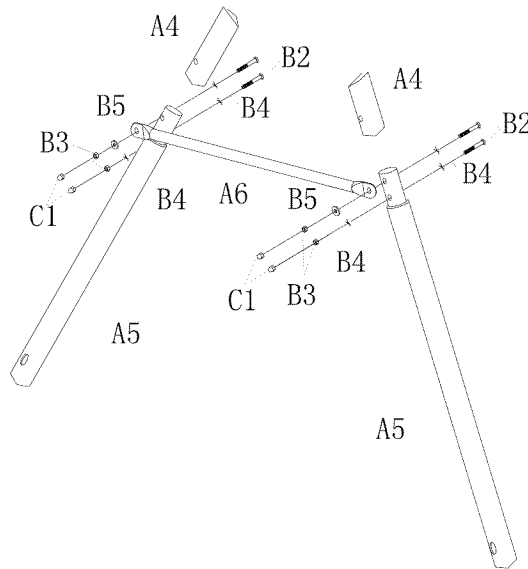

### Step 4

- Insert J3 which is pre-assembled with J1, K2 and J4 into holes on A1.
- Secure it with J2, J6 and K3.
- Repeat for remaining two chains on A1.

## Step 5

- Attach K1 to J4.
- Secure with J5, J6 and K3.
- Repeat for remaining One swing seat.

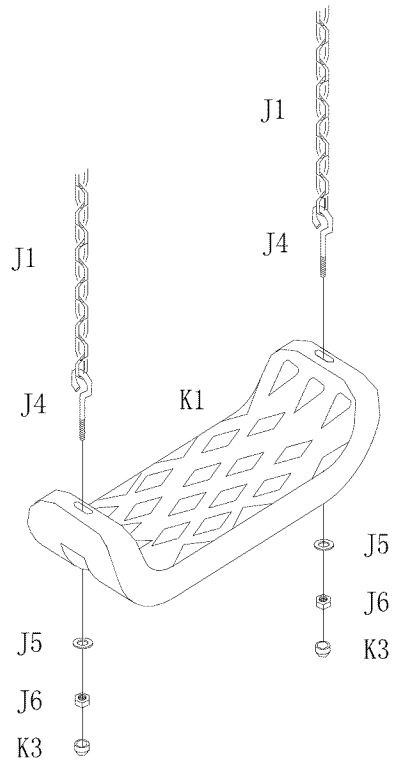

## Step 6

- Attach P1 to S1.
- Attach S1 to A3.
- Secure using S5, S6 and T4.

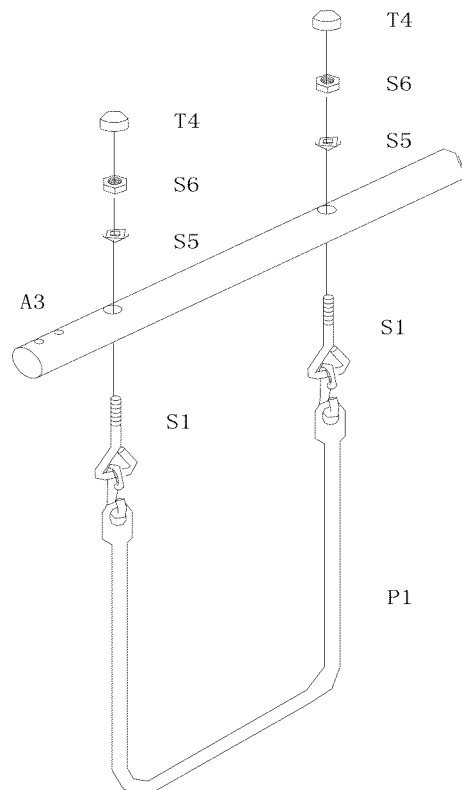

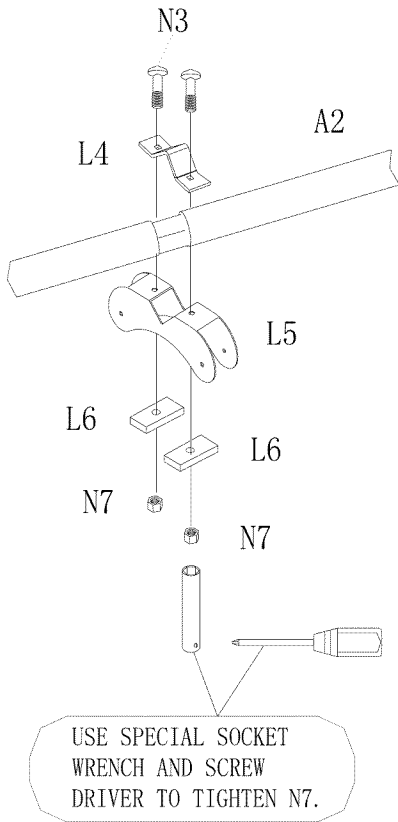

### Step 7

- Attach L4, L5 and L6 to A2 as shown.
- Secure using N3 and N7.
- Use special socket wrench and screw driver to tighten.

### Step 8

- Attach M5 to L2.
- Secure using N5.
- Attach L2 to L1 and align holes.
- Secure using N4, N10 and N8.
- Insert M1 into L1 if not pre-assembled. Attach M1 to the top of L1 and insert M2 into M1 and align if not pre-assembled.

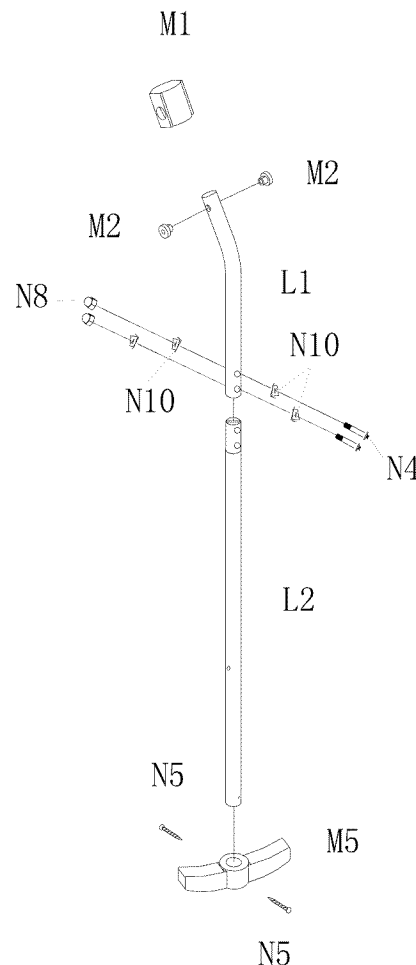

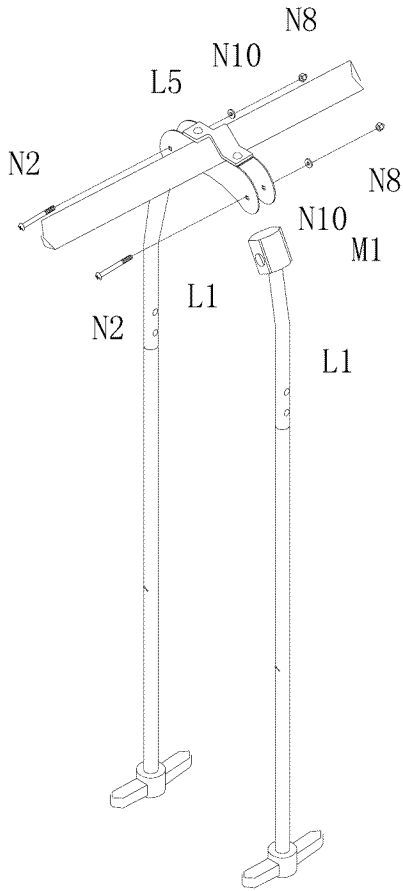

### Step 9

- Attach L1 to L5.
- Secure using N2, N10 and N8.

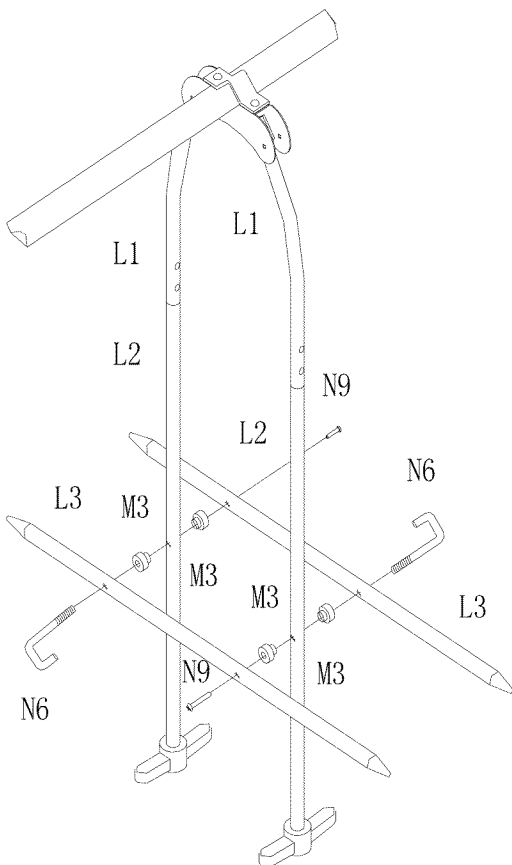

### Step 10

- Insert M3 into L2 if not pre-assembled.
- Attach L3 to outer sides of L2.
- Secure using N6 and N9. See diagram for sequence.

### Step 11

- Attach M4 to L3 .
- Secure using N1,N10 and N8.

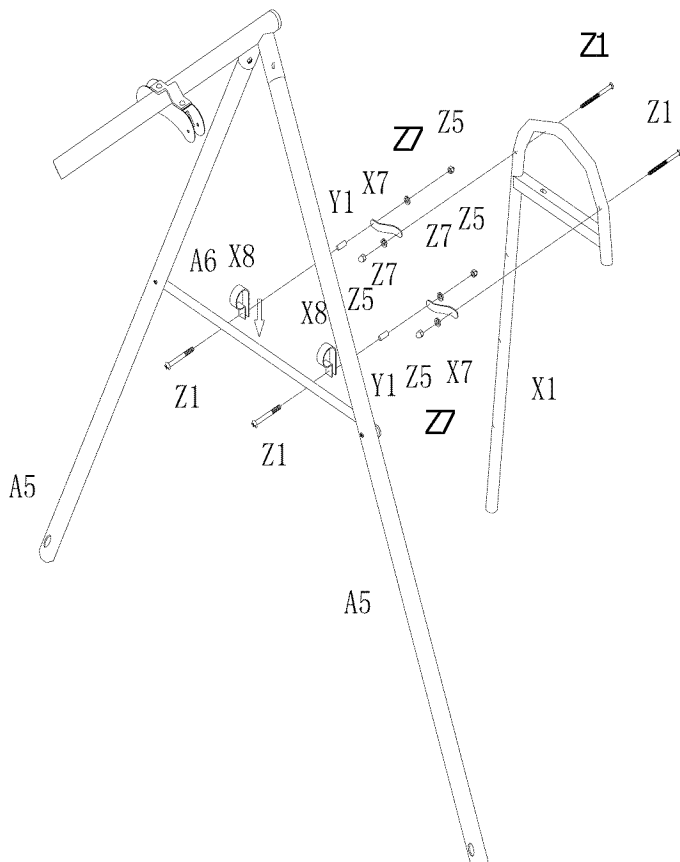
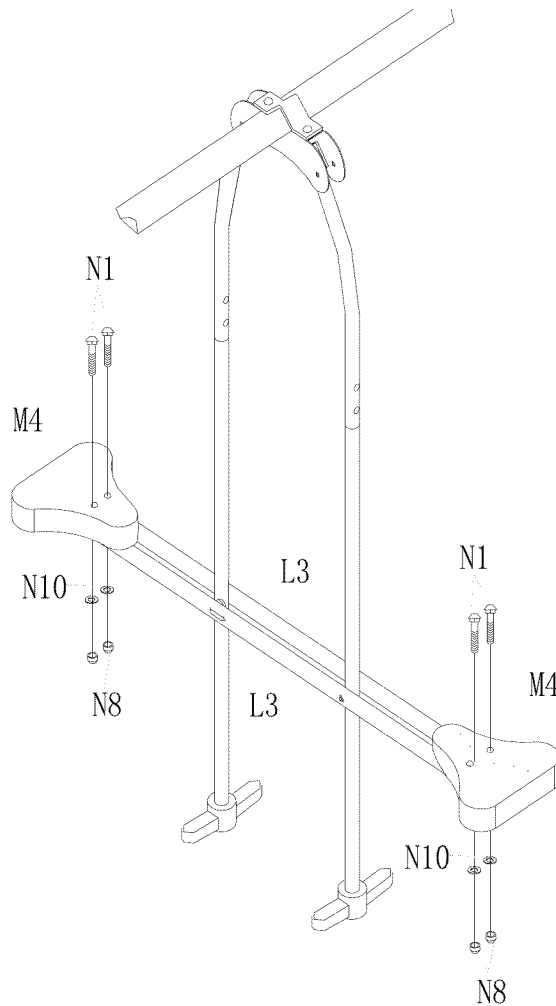

### Step 12

- Attach X8 to A6 as shown.
- Attach Z1, X7,Y1,Z7 to X8 and secure with Z5. Do not over-tighten Z5 to allow room for adjustment.
- Attach X1 to X7.
- Secure using Z1 and Z5.

### Step 13

- Attach X5 to Y2.
- Secure using Z1 and Z4.
- Attach X4 to Y2. Note: make sure the bolt holes face up.
- Insert Y3 into X4 if not pre-assembled.

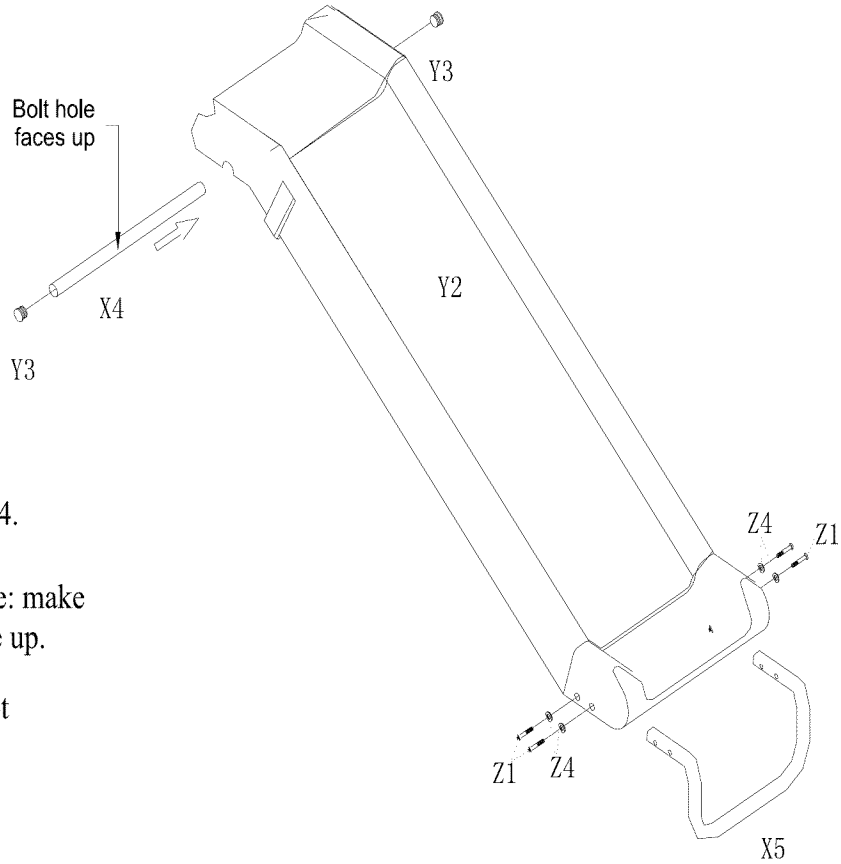

### Step 14

- Attach X6 to X1 and X2.
- Secure each side using Z1, Z7 and Z5.
- Attach X3 to X1 and X2.
- Align holes and hold in position.

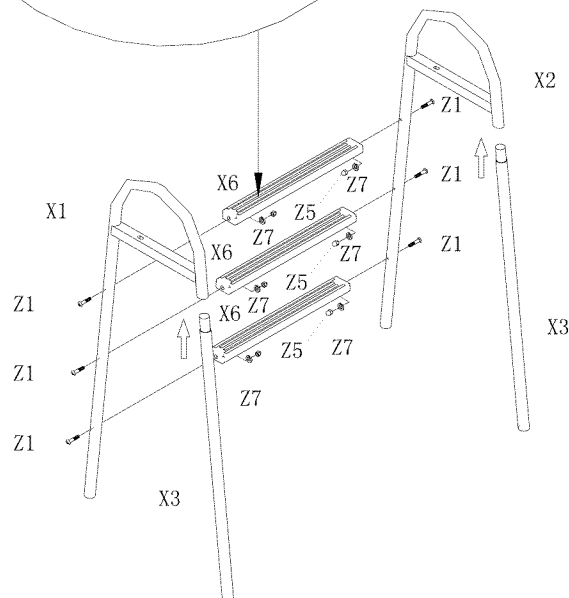
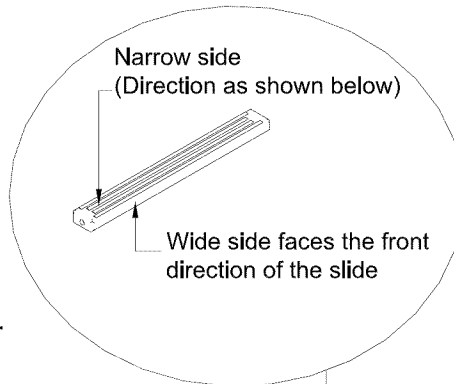

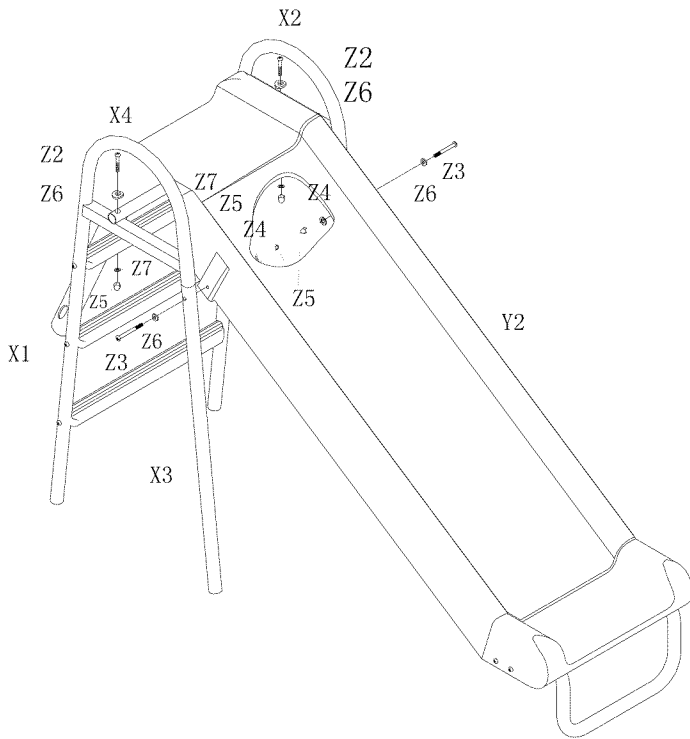

## Step 15

- **Attach slide assembly from Step 13 to X1 and X2.**
- **Secure using Z2, Z6, Z7, and Z5 as shown.**
- **Insert Z3 into Z6 and inset into X1, X2 and X3 as shown.**
- **Secure with Z4 and Z5.**

You have finished assembling your playground equipment.  
Now go back and securely tighten all nuts and bolts before using the playground equipment.

**NOTE: Do not let children use the playground equipment until it is properly assembled and anchored.**

## OPTIONAL ANCHORS

(NOTE: ANCHORS ARE NOT INCLUDED, SOLD SEPARATELY)

By anchoring your set with Ground Anchors, you will be able to move your gym set at a future date. Either method is suitable for hard soil (clay, etc.). If your soil is soft (sand, etc.), the corkscrew method is recommended. If you wish to permanently secure your gym set, either type of anchor may set in concrete. Ensure equipment is firmly anchored (cementing is usually recommended). When equipment is cemented, do not bury the legs more than three inches below the ground surface. This will ensure sufficient space remains under the swinging plays. Be certain that all anchoring devices (including concrete) are placed below the level of the playing surface or below ground level to prevent tripping.

### Corkscrew Anchors is not included

Be sure the swing set is located on level ground

Turn the corkscrew anchor into the ground until only the hooked end is above the ground next to the leg.

Insert the hooked end into the bottom opening of the leg.

Ensure that the hooked end is secure in the leg opening.

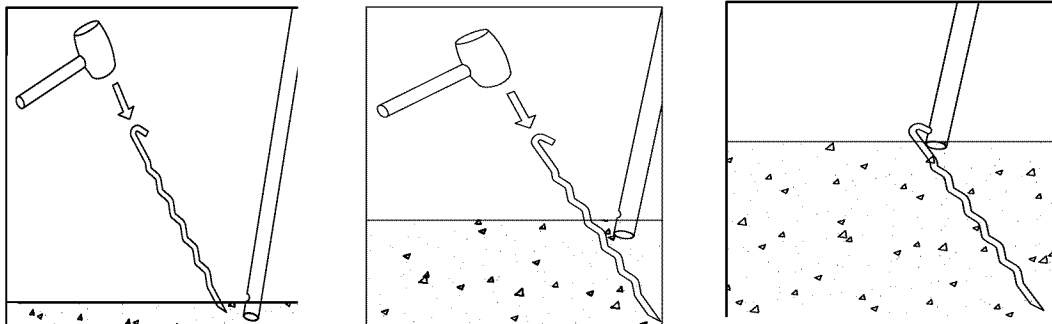

### NOTE: ANCHORING, ANCHOR SOLD SEPRATELY

- Anchoring in concrete should be done for this swing set if it is not possible, you may purchase anchors at 1-866-884-0535.
- If the swing set is set up on grounds with sandy soil condition, it must be anchored with concrete footing( concrete not included)
- Be sure the swing set is located in level ground
- Dig holes around swing leg tube as shown below in drawing. As you dig down and create a cylindrical hole, you should use shovel to carve out the lower part of the hole, to create a larger diameter hole bottom
- Place 2 inches brick or gravel bed as shown in drawing below
- Use about 45lb of concrete per leg
- Cover concrete with dirt and protective surface material
- Allow about 6-7 days for concrete to dry properly



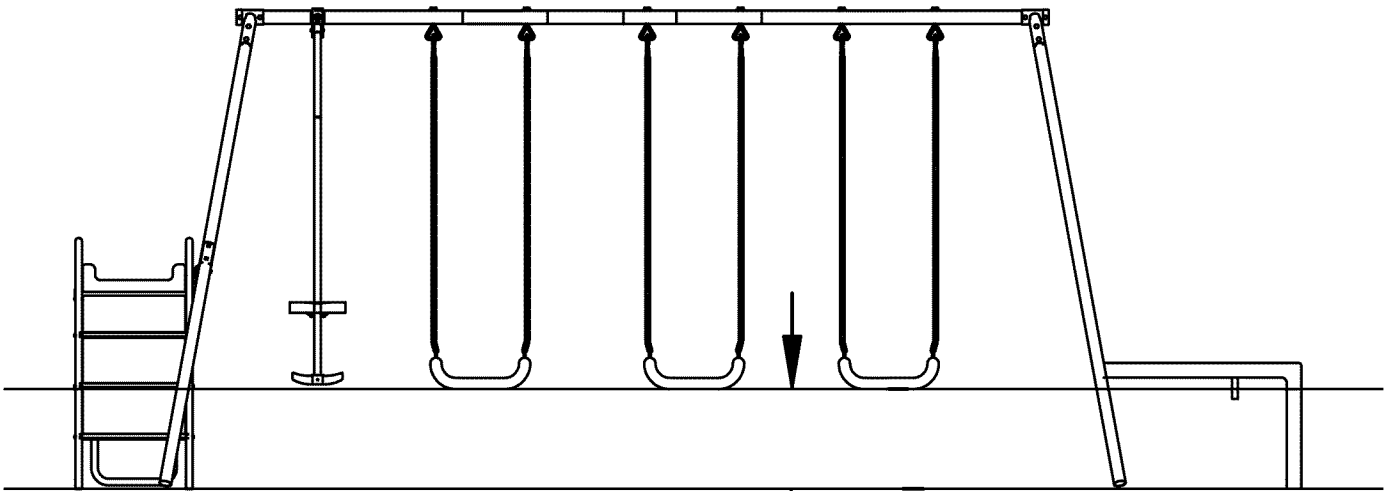
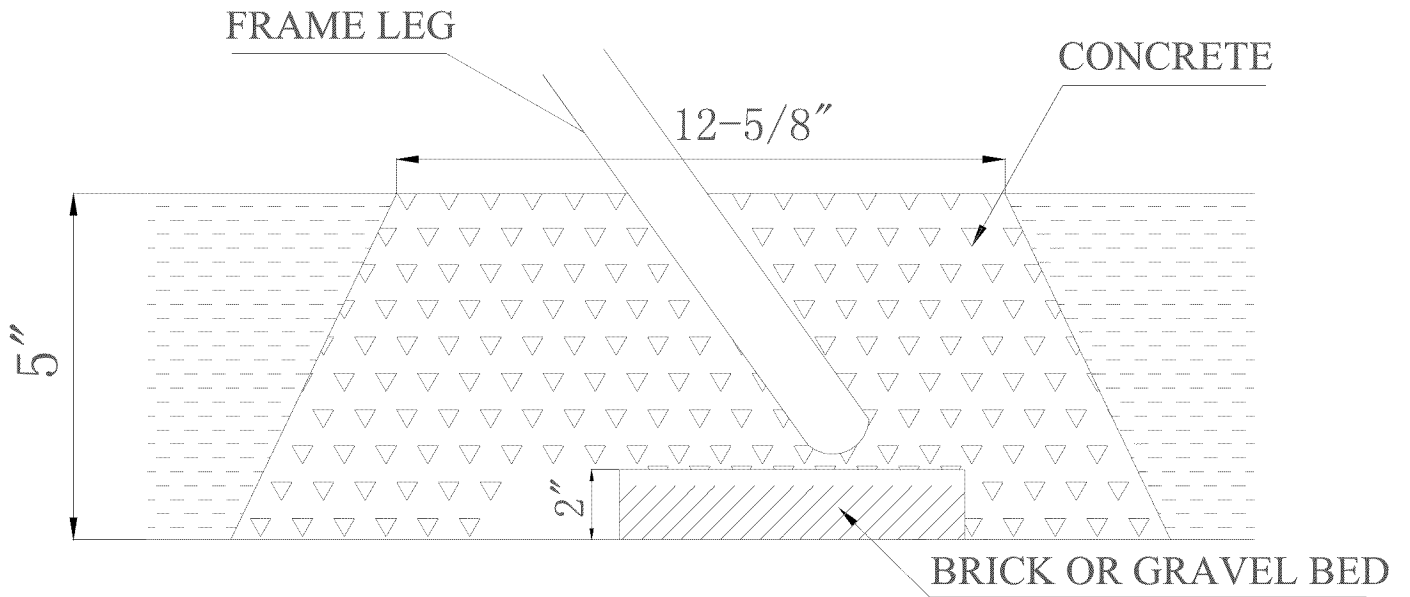

YOU MUST MAINTAIN A MINIMUM OF 8 INCHES OF GROUND CLEARANCE

## **MANUFACTURER'S LIMITED WARRANTY**

SPORTSPOWER LTD. warrants its GYM products for (180) days against defects in material, workmanship and rust painted parts which compromises the structural integrity of the product when used for the purpose intended, normal conditions, and provided it receives proper care and maintenance. Surface rust is not covered under warranty.

**This warranty coverage extends only to the original purchaser with a receipt and non-transferable. All products for which a warranty claim is made must be received by SPORTSPOWER's authorized service center, freight prepaid, and accompanied by sufficient proof of purchase during the warranty period.**

**This limited Warranty does not cover our products which: fail due to (1) normal wear; (2) abuse and neglect; (3) improper maintenance; (4) unauthorized repairs or alterations; or (5) are used for commercial or other income producing purposes; or (6) accidents and misuse.**

**All warranty repairs must be authorized by SPORTSPOWER Customer Service before repairs are made.**

**IMPORTANT: A missing part is not considered the same thing as a defective part or unit. If a part is missing, there is no need to return the entire unit to the store. In order to obtain fast replacement parts or service as provided by this warranty, please call the number below.**

**CUSTOMER SERVICE:  
DO NOT RETURN TO THE STORE ,  
PLEASE CALL  
1-866-884-0535**

**Monday-Friday, 8:00AM-5:00PM Eastern Time  
[www.Sportspowercustomerservice.com](http://www.Sportspowercustomerservice.com)**

**Sportspower Ltd  
Flat M, 3/Floor, Kaiser Estate Phase 3, 11 Hok Yuen Street,  
Hungghom, Kowloon, HongKong**

## Free Manuals Download Website

<http://myh66.com>

<http://usermanuals.us>

<http://www.somanuals.com>

<http://www.4manuals.cc>

<http://www.manual-lib.com>

<http://www.404manual.com>

<http://www.luxmanual.com>

<http://aubethermostatmanual.com>

Golf course search by state

<http://golfingnear.com>

Email search by domain

<http://emailbydomain.com>

Auto manuals search

<http://auto.somanuals.com>

TV manuals search

<http://tv.somanuals.com>