

MG25 DuraGate

FOR OPENINGS 26.5" (67cm) - 41.5" (105cm) • Average installed height 29.5" (75cm)

ASSEMBLY INSTRUCTIONS

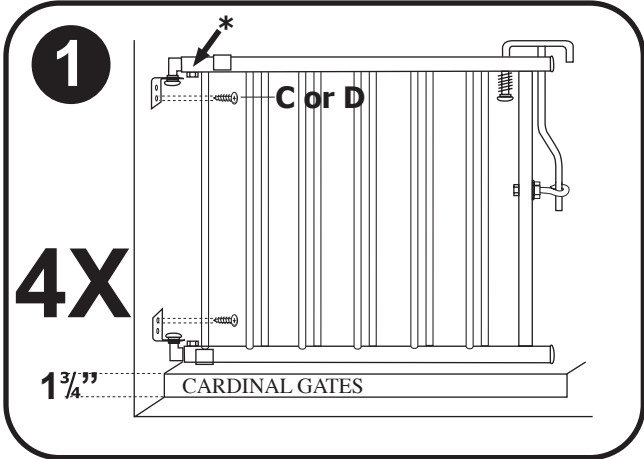
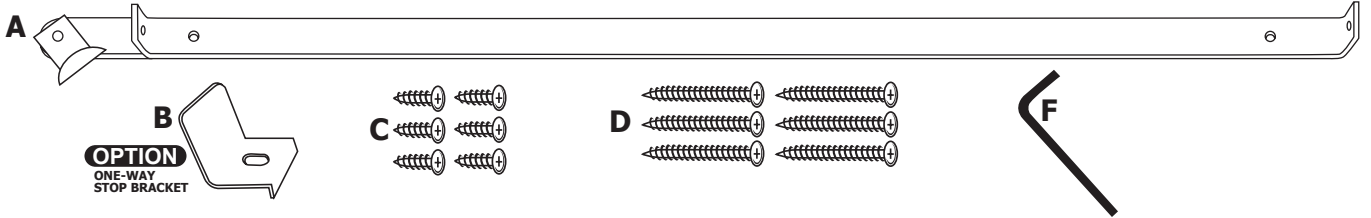

- 1.** Place gate on top of carton to establish height. Use short screws (C) for doorframes or longer screws (D) into drywall to reach a stud.

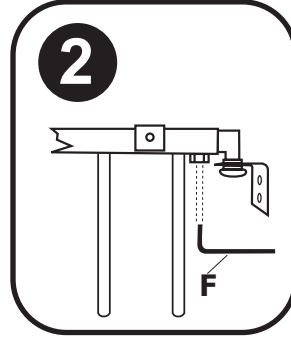

- 2.** Level gate by adjusting telescoping tube attached to upper gate with allen wrench (F).

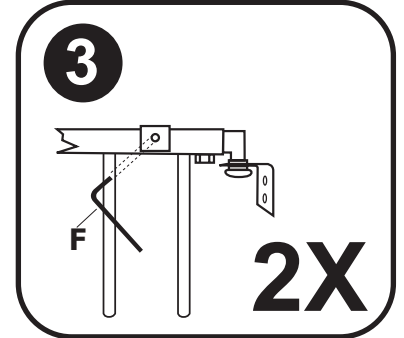

- 3.** Loosen width adjustment set screws at top and bottom of gate with allen wrench (F) slightly to allow gate to expand. **Keep plastic shipping tabs in place.**

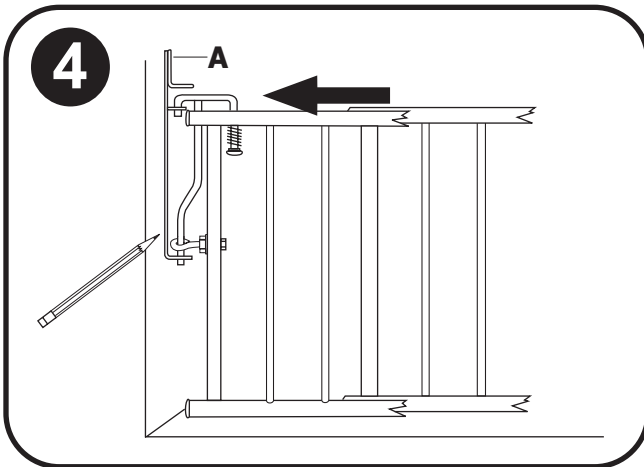

- 4.** Attach latch bracket (A) to latch rod with bracket snug against bottom of eye bolt. Expand gate so that latch bracket (A) is against mounting surface. Mark holes.

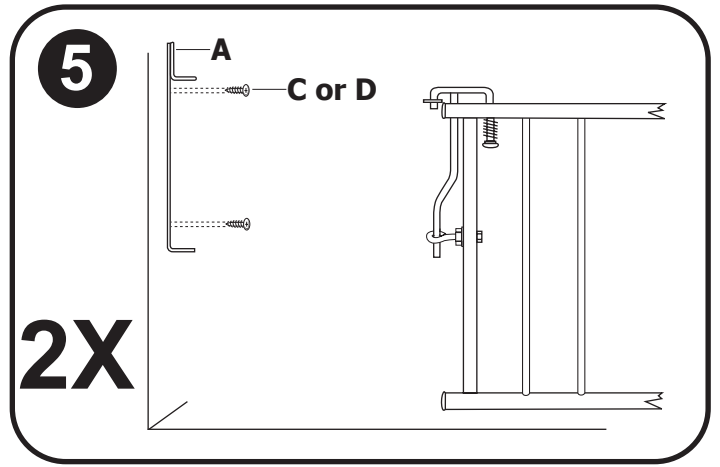

- 5.** Separate bracket from rod and mount as marked. **FOR ONE-WAY OPERATION:** Read **STEP SEVEN** and install safety bracket on bottom hole.

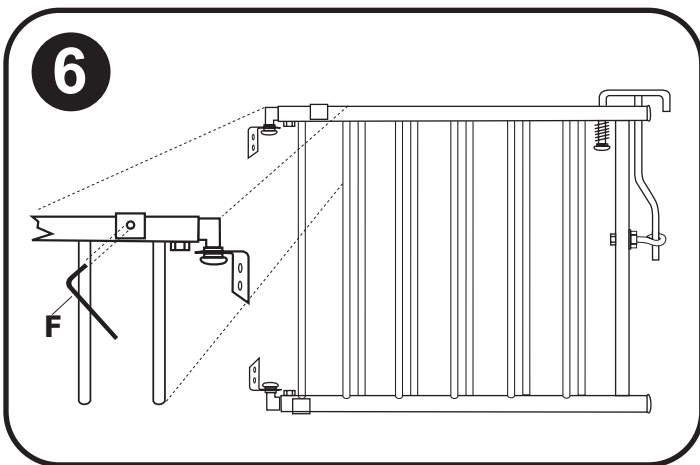

- 6.** Use Allen wrench (F) to tighten adjustment set screws after removing plastic shipping tabs.

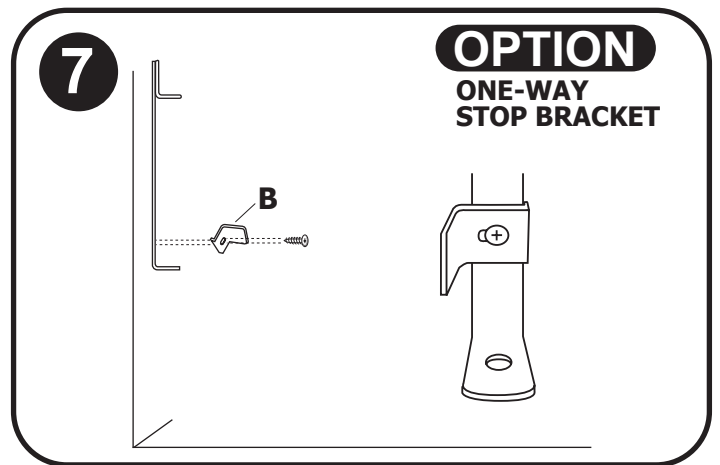

- 7.** Install one-way stop bracket (B) on one side of latch if you wish to have gate open in only one direction.

WARNING: TO PREVENT SERIOUS INJURY OR DEATH, SECURELY INSTALL GATE OR ENCLOSURE AND USE ACCORDING TO MANUFACTURER'S INSTRUCTIONS. NEVER USE WITH A CHILD ABLE TO CLIMB OVER OR DISLODGE/OPEN THE GATE ENCLOSURE. NEVER LEAVE CHILD UNATTENDED. USE ONLY WITH THE LOCKING/LATCHING MECHANISM SECURELY ENGAGED.

Download from www.Somanuals.com. All Manuals Search And Download.

GATE OPERATION

TO OPEN:

Use thumb to push pendulum to the side while raising latch rod with finger.

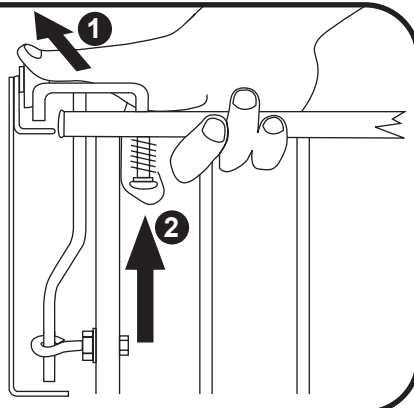

FOR CLOSING:

Simply raise latch rod, push against pendulum, and drop into holes.

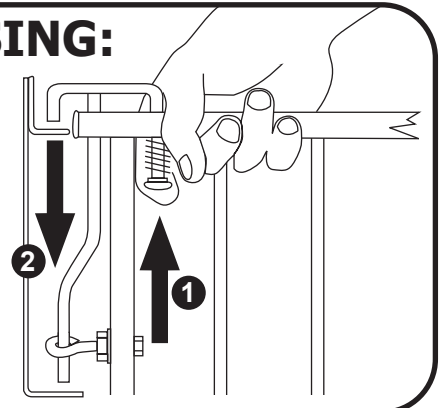

GATE MAINTENANCE

This gate is all steel with a tough powder-coat finish. To clean, wash gently with mild soap or detergent and lukewarm water using a soft cloth or sponge. Wipe clean.

GATE CARE & REMINDERS

At **CARDINAL GATES, INC.**, we design what we believe to be the very best, and most user friendly gates available. Our gates are built to last many years with proper use and care. Here are a few suggestions...

- Close gates gently - do not slam - to prevent damage to latch mechanism.
- When closing, be sure safety bracket on gate frame engages as depicted in instructions.
- For safety, always close gate when not in use. Children should not be allowed to swing on an open gate as this can damage hinge mount.
- Keep allen wrench in a secure place. We suggest removing set screws when separating sections for cleaning. Periodically check all screws, bolts, etc. for security and proper adjustment.

CARDINAL GATES, INC., offers many accessories such as extensions, stair kits, and other safety products. Check with your dealer or call **CARDINAL GATES, INC.** at 1-800-318-3380.

We sincerely hope that you thoroughly enjoy many years of service from your **CARDINAL GATE**.

GATE WARRANTY

Your Cardinal Gate is warranted to be free of manufacturing defects for a period of one year from the date of purchase when used in homes, and according to manufacturers instructions. When used commercially, such as day care centers, the warranty is 90 days.

Cardinal Gates, Inc. will either repair or replace, at our option, any parts necessary to correct defects in material or workmanship during the warranty period. The warranty disclaims liability for incidental, special and consequential damages of any nature.

TO EXERCISE WARRANTY:

Ship your gate in a protective carton, freight prepaid to:
CARDINAL GATES, INC.
79 Amlajack Way
Newnan, GA 30265

You must include the following:

1. Proof of purchase (store receipt, etc.).
2. Brief note describing problem with gate.
3. Full return address along with phone number.

FOR FURTHER ASSISTANCE

Call 1-800-318-3380

CARDINAL GATES

If it's a Cardinal, It's the Best!

79 Amlajack Way
Newnan, GA 30265
770-252-4200

www.cardinalgates.com

Free Manuals Download Website

<http://myh66.com>

<http://usermanuals.us>

<http://www.somanuals.com>

<http://www.4manuals.cc>

<http://www.manual-lib.com>

<http://www.404manual.com>

<http://www.luxmanual.com>

<http://aubethermostatmanual.com>

Golf course search by state

<http://golfingnear.com>

Email search by domain

<http://emailbydomain.com>

Auto manuals search

<http://auto.somanuals.com>

TV manuals search

<http://tv.somanuals.com>