

Installation, Start-Up and Service Instructions

CONTENTS

	Page
SAFETY CONSIDERATIONS	1
INSTALLATION	1-31
Step 1 – Complete Pre-Installation	
Checks	1
Step 2 – Rig and Place Unit	4
• RIGGING	
• PLACING THE UNIT	
Step 3 – Complete Refrigerant Piping	4
• GENERAL	
• COIL REFRIGERANT PIPING INSTALLATION	
• TUBING PACKAGE INSTALLATION	
• THREE AND FOUR COIL SPLIT, COIL CIRCUITING APPLICATIONS; 054-084 UNITS ONLY	
• REFRIGERANT LINE SIZING	
• LIQUID SHUTOFF VALVE AND SIGHT GLASS	
• PRESSURE RELIEF	
• REFRIGERANT RECEIVER	
• LIQUID LIFT	
Step 4 – Complete Electrical	
Connections	23
• GENERAL	
• FIELD CONNECTIONS	
• MAIN POWER WIRING	
• CONTROL CIRCUIT POWER WIRING	
• GENERAL WIRING NOTES	
• DESCRIPTION OF CONTROLS	
Step 5 – Add Accessories as Needed	31
START-UP	32
System Evacuation and Dehydration	32
Charging Procedure	32
Check Operation of Condenser Fan Motor	
Controls and Rotation of Fans	32
SERVICE	32-34
Cleaning Condenser Coils	32
Condenser Fans	32
Lubrication	32
Head Pressure Control	32
• FAN CYCLING	

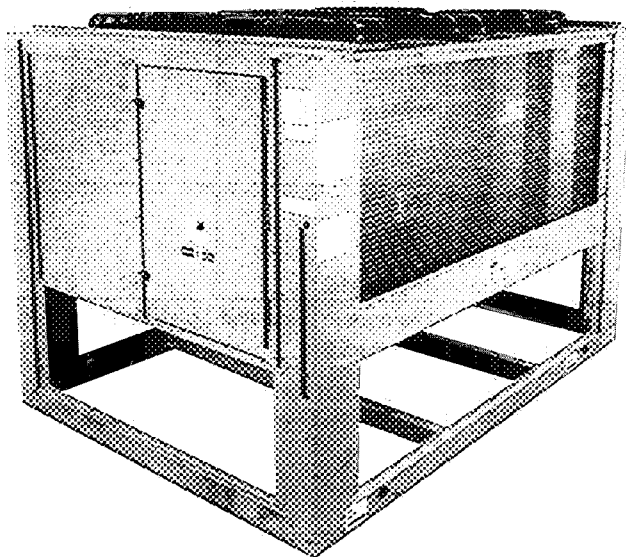

Fig. 1 – Model 09DK (084 Shown)

When working on the equipment, observe precautions in the literature and on tags, stickers, and labels attached to the equipment.

Follow all safety codes. Wear safety glasses and work gloves. Keep quenching cloth and fire extinguisher nearby when brazing. Use care in handling, rigging and setting bulky equipment.

See Tables 1A and 1B for Physical Data.

	<p>ELECTRIC SHOCK HAZARD</p> <p>Separate power sources (main and control power circuits) are used for these units. Be sure both main and control power circuits are disconnected before servicing.</p>
--	--

INSTALLATION

Step 1 – Complete Pre-Installation Checks – Examine for damage incurred during shipment. File claim immediately with transit company if damage is found. Check the shipment for completeness. Verify that the nameplate electrical requirements match the available power supply.

SAFETY CONSIDERATIONS

Installing, starting up, and servicing air-conditioning equipment can be hazardous due to system pressures, electrical components, and equipment location (roofs, elevated structures, etc.).

Only trained, qualified installers and service mechanics should install, start up, and service this equipment (Fig. 1).

Untrained personnel can perform basic maintenance functions such as cleaning coils. All other operations should be performed by trained service personnel.

**Table 1A – Physical Data 60 Hz
English**

09DK	054	064	074	084	094
NOMINAL TONS	50	60	70	80	90
OPERATING WEIGHT-lb					
Cu-Al*	1695	1845	2200	2421	2850
Cu-Cu†	1983	2278	2617	3099	3560
SHIPPING WEIGHT-lb**					
Cu-Al*	2010	2136	2521	2725	4415
Cu-Cu†	2298	2569	2938	3403	5150
REFRIGERANTS	R-134A, R-22, R-12, R-500, R-502				
NOMINAL HEAT REJECTION (TONS)††	65.8	78.6	95.4	103.5	116.3
CONDENSER FANS					
No. of Blades	4	4	4	4	4
No. of Fans	4	4	6	6	6
Fan Diameter-in.	30	30	30	30	30
Airflow-cfm	35,000	35,000	52,000	51,000	57,000
Fan Speed-rpm	1140	1140	1140	1140	1140
Fan Motor-hp	1	1	1	1	1
CONDENSER COILS					
Quantity	4	4	4	4	4
Fins/in.	17	17	17	17	17
No. of Rows	2	3	2	3	3
Total Face Area (sq ft)	80.5	80.5	116.7	116.7	128.3

TD – Temperature Difference = Saturated Condensing Temperature – Entering-Air Temperature

*Copper tubes and aluminum fins

†Copper tubes and copper fins.

**Packaging option includes skid and coil protection.

††Nominal heat rejection based on refrigerant R-22, 15° F subcooling, and a 30° F temperature difference (TD).

SI

09DK	054	064	074	084	094
NOMINAL kW	176	211	246	281	316
OPERATING WEIGHT-kg					
Cu-Al*	769	837	998	1098	1293
Cu-Cu†	900	1033	1187	1406	1615
SHIPPING WEIGHT-kg**					
Cu-Al*	912	969	1144	1236	2003
Cu-Cu†	1042	1165	1333	1544	2336
REFRIGERANTS	R-134A, R-22, R-12, R-500, R-502				
NOMINAL HEAT REJECTION (kW)††	231	276	335	364	409
CONDENSER FANS					
No. of Blades	4	4	4	4	4
No. of Fans	4	4	6	6	6
Fan Diameter-mm	762	762	762	762	762
Airflow-L/s	16 520	16 520	24 540	24 070	26 900
Fan Speed-r/s	19	19	19	19	19
Fan Motor-kW	0.746	0.746	0.746	0.746	0.746
CONDENSER COILS					
Quantity	4	4	4	4	4
Fins/m	669	669	669	669	669
No. of Rows	2	3	2	3	3
Total Face Area (sq m)	7.5	7.5	10.84	10.84	11.92

TD – Temperature Difference = Saturated Condensing Temperature – Entering-Air Temperature

*Copper tubes and aluminum fins.

†Copper tubes and copper fins.

**Packaging option includes skid and coil protection.

††Nominal heat rejection based on refrigerant R-22, 8.3° C subcooling, and a 16.7° C temperature difference (TD)

**Table 1B – Physical Data 50 Hz
English**

09DK	054	064	074	084	094
NOMINAL TONS	50	60	70	80	90
OPERATING WEIGHT-lb					
Cu-Al*	1695	1845	2200	2421	2850
Cu-Cu†	1983	2278	2617	3099	3560
SHIPPING WEIGHT-lb**					
Cu-Al*	2010	2136	2521	2725	4415
Cu-Cu†	2298	2569	2938	3403	5150
REFRIGERANTS	R-134A, R-22, R-12, R-500, R-502				
NOMINAL HEAT REJECTION (TONS)††	65.8	78.6	95.4	103.5	116.3
CONDENSER FANS					
No. of Blades	6	6	6	6	6
No. of Fans	4	4	6	6	6
Fan Diameter-in.	30	30	30	30	30
Airflow-cfm	35,000	35,000	52,000	51,000	57,000
Fan Speed-rpm	950	950	950	950	950
Fan Motor-hp	1	1	1	1	1
CONDENSER COILS					
Quantity	4	4	4	4	4
Fins/in.	17	17	17	17	17
No. of Rows	2	3	2	3	3
Total Face Area (sq ft)	80.5	80.5	116.7	116.7	128.3

TD – Temperature Difference = Saturated Condensing Temperature – Entering-Air Temperature

*Copper tubes and aluminum fins.

†Copper tubes and copper fins.

**Packaging option includes skid and coil protection.

††Nominal heat rejection based on refrigerant R-22, 15° F subcooling, and a 30° F temperature difference (TD)

SI

09DK	054	064	074	084	094
NOMINAL kW	176	211	246	281	316
OPERATING WEIGHT-kg					
Cu-Al*	769	837	998	1098	1293
Cu-Cu†	900	1033	1187	1406	1615
SHIPPING WEIGHT-kg**					
Cu-Al*	912	969	1144	1236	2003
Cu-Cu†	1042	1165	1333	1544	2336
REFRIGERANTS	R-134A, R-22, R-12, R-500, R-502				
NOMINAL HEAT REJECTION (kW)††	231	276	335	364	409
CONDENSER FANS					
No. of Blades	6	6	6	6	6
No. of Fans	4	4	6	6	6
Fan Diameter-mm	762	762	762	762	762
Airflow-L/s	16 520	16 520	24 540	24 070	26 900
Fan Speed-r/s	15.8	15.8	15.8	15.8	15.8
Fan Motor-kW	0.746	0.746	0.746	0.746	0.746
CONDENSER COILS					
Quantity	4	4	4	4	4
Fins/m	669	669	669	669	669
No. of Rows	2	3	2	3	3
Total Face Area (sq m)	7.5	7.5	10.84	10.84	11.92

TD – Temperature Difference = Saturated Condensing Temperature – Entering-Air Temperature

*Copper tubes and aluminum fins.

†Copper tubes and copper fins.

**Packaging option includes skid and coil protection.

††Nominal heat rejection based on refrigerant R-22, 8.3° C subcooling, and a 16.7° C temperature difference (TD).

Step 2 – Rig and Place Unit

RIGGING — The 09DK units are designed for overhead rigging and this method should be used. Lifting holes are provided in the frame base rails, which are marked for rigging (see rigging label on the unit). It is recommended that field supplied pipes of sufficient length that extend beyond the frame are passed through the holes. Attach cables, chains, or straps to both ends of the pipes. Use spreader bars or a frame to keep the cables, chains, or straps clear of the unit sides. All cables should run to a central suspension point so that the angle from the horizontal is not less than 45 degrees. See Fig. 2-4 and Tables 1A and 1B for weight distribution information. Standard coil protection packaging provides some protection to the unit. Raise and set the unit down carefully.

Domestic Units With No Overhead Rigging— Standard condenser packaging consists of coil protection only. Skids are not provided as part of the standard packaging. If overhead rigging is not available at the jobsite, place the unit on a skid or pad by using jacks at the rigging points before dragging or rolling. When rolling, use a minimum of 3 rollers. When dragging, pull the pad or skid. *Do not apply pressure to the unit.* Raise from above to lift off the pad or skid when in final position. See rigging section above for more information.

Export and Domestic Units With Skids— All export units are mounted on skids with vertical coil protection. Leave the unit on the skid until it is in the final position. While on the skid, the unit can be rolled, dragged or forklifted; *do not apply force to the unit.* Use a minimum of 3 rollers when rolling, and raise from above to remove the skid when unit is in the final position. See preceding rigging procedure for more information.

▲ CAUTION

To avoid damage to units, do not forklift them unless they are attached to skids designed for forklifting. Forklift trucks used to lift units on skids must have forks a minimum of 60 in. (1524 mm) long.

PLACING THE UNIT — Locate the condenser where an adequate supply of outdoor air is available for the unit inlet. Do not locate where the possibility of air recirculation exists, such as under a roof overhang. Also, locate the condenser in an area free from airborne dirt or other foreign material which could clog the condenser coils. Refer to Fig. 2-4 for airflow clearances. For multiple units, allow 8 ft (2440 mm) separation between units for airflow and service. Placement area must be level and strong enough to support operating weight of the unit (Fig. 2-4 and Tables 1A and 1B). It is recommended to bolt unit securely to pad when unit is positioned and leveled. Fasteners for mounting unit are field supplied. If vibration isolators are required for a particular installation, refer to the unit weight distribution data tables in Fig. 2-4 to help select the proper isolators.

Step 3 – Complete Refrigerant Piping

GENERAL — All field leak and pressure testing should be in accordance with local code requirements. If a local code does not exist, use ASHRAE (American Society of Heating, Refrigeration and Air Conditioning Engineers) Standard 15, Safety Code for Mechanical Refrigeration.

For leak testing procedures, refer to the Carrier “Refrigerant Service Techniques” book, Form SM-1A

For any parts that need to be removed, use a mini tubing cutter. Perform phos-copper brazing on all field-made connections while protecting adjacent joints from heat.

Install or replace filter-drier(s).

COIL REFRIGERANT PIPING INSTALLATION — Hot gas and liquid connections are located on the same end and have a heat-shrunk cap, which ensures a clean joint for field piping. The coil circuiting is designed to provide several selections of coil splits to satisfy various applications (See Table 2), with piping connections made in the field. In all cases where circuits are field connected, the piping connections should be made within the unit cabinet. The hot gas lines should enter and the liquid lines should leave the condenser at the header end of the unit.

A tubing package for headering, including two fan cycle pressure switches (FCPSs) and hardware, is provided for the 100, 50/50, and nominal 67/33% (054-084 only) condenser coil circuiting options. The tubing also provides ports for easy FCPS installations. The ports come with a 1/4-in. male flare fitting and check valve for each FCPS replacement. Tubing and FCPSs are field installed regardless of circuiting. Tubing packages are not offered for the 33/33/33% and 33/33/17/17% coil circuiting options; tubing for these coil circuit options must be field fabricated and installed. See Fig. 5-7 for tubing package contents

NOTE. 67/33, 33/33/33 and 33/33/17/17% represent average coil split combinations. Refer to sections below for actual values for your particular coil split combination. Note that 09DK094 units can only have 100% or 50/50% splits.

IMPORTANT: With the 67/33, 33/33/33, and 33/33/17/17% capacity split options, 3 or 4 FCPSs are used. For these applications, an accessory fan control kit is required. See accessory installation instructions for more information.

Figure 8 shows a typical piping application for a condenser with a multiple-split system. Figure 9 shows the typical field piping arrangements for the 09DK units. See Fig. 10 and 11 for coil connection details. Figures 12 and 13 show typical factory supplied coil circuiting and typical field installed 67/33% coil split circuiting, respectively.

Table 2 – Coil Circuiting Options

09DK	09DK CIRCUITING OPTIONS				
054	100%	50/50%	66/34	34/34/32	34/34/16/16
064	100%	50/50%	66/34	34/34/32	34/34/16/16
074	100%	50/50%	68/32	32/32/36	32/32/18/18
084	100%	50/50%	67/33	33/33/33	33/33/17/17
094	100%	50/50%	—	—	—

NOTES:

1. The approximate operating weight of the unit is:

- 09DK-054--- → 1695 lb [769 kg]
- 09DK-054--C → 1983 lb [900 kg]
- 09DK-064--- → 1845 lb [837 kg]
- 09DK-064--C → 2278 lb [1033 kg]

2. Unit must have clearances for airflow as follows:

- Top — Do not restrict in any way.
- Ends — 5 ft [1524 mm]
- Sides — 6 ft [1829 mm]

3. All units are shipped with a capacity split tubing kit. This kit may be used by the field to obtain 100%, 50%/50% and 67%/33% capacity splits. To obtain a 33%/33%/33% capacity split, coils must be manifolded by the field. Coils are factory circled for a 33%/33%/17%/17% capacity split.

UNIT	DIMENSION		OPERATING CORNER WEIGHTS			
	Y	X	A	B	C	D
09DK-054---	3'-6 1/16" [1084 mm]	4'-1 1/8" [1222 mm]	452 lb [205 kg]	425 lb [193 kg]	425 lb [193 kg]	422 lb [191 kg]
09DK-054-C	3'-6 7/8" [1090 mm]	4'-5 1/16" [1227 mm]	524 lb [238 kg]	497 lb [225 kg]	468 lb [212 kg]	494 lb [224 kg]
09DK-064---	3'-6 3/4" [1087 mm]	4'-3 1/16" [1224 mm]	489 lb [222 kg]	462 lb [210 kg]	434 lb [197 kg]	459 lb [208 kg]
09DK-064-C	3'-7 1/8" [1095 mm]	4'-1 1/2" [1232 mm]	598 lb [271 kg]	571 lb [259 kg]	542 lb [246 kg]	568 lb [258 kg]

CONTROL BOX
END

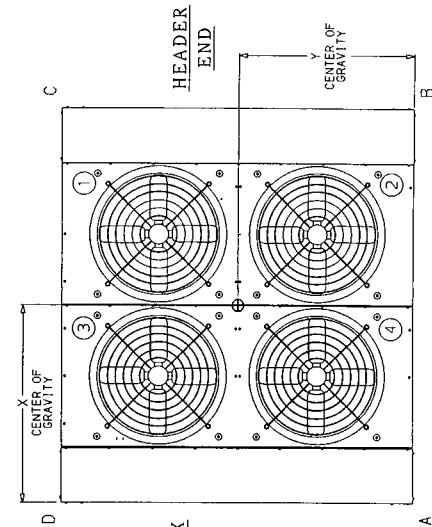

CAPACITY SPLIT	CONNECTIONS		SIZE
	TYPE	NO. 5	
100%	HOT GAS	1, 3, 5, 7	1 1/8" I.D.
	LIQUID	2, 4, 6, 8	7/8" I.D.
50%/50%	HOT GAS	1, 3	5/8" I.D.
	LIQUID	2, 4	7/8" I.D.
67%/33%	HOT GAS	1, 3, 5	7/8" I.D.
	LIQUID	2, 4, 6	7/8" I.D.
33%/33%/33%	HOT GAS	1	7/8" I.D.
	LIQUID	2	7/8" I.D.
33%/33%/17%/17%	HOT GAS	1	7/8" I.D.
	LIQUID	2	7/8" I.D.

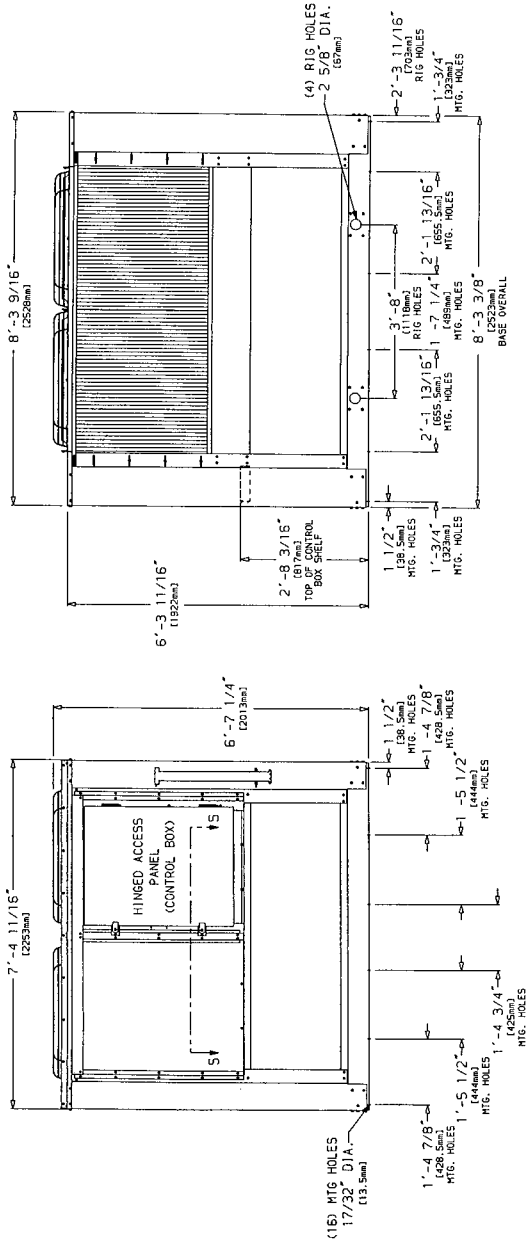

Fig. 2 — Dimensions; 054 and 064 Units

NOTES:

- The approximate operating weight of the unit is:
 - 09DK-074--- → 2200 lb [998 kg]
 - 09DK-074---C → 2617 lb [1187 kg]
 - 09DK-084--- → 2421 lb [1098 kg]
 - 09DK-084---C → 3099 lb [1406 kg]
- Unit must have clearances for airflow as follows:
 - Top — Do not restrict in any way.
 - Ends — 5 ft [1524 mm]
 - Sides — 6 ft [1829 mm]

3. All units are shipped with a capacity split tubing kit. This kit may be used by the field to obtain 100%, 50%/50% and 67%/33% capacity splits. To obtain a 33%/33%/33% capacity split, coils must be manifolded by the field. Coils are factory circuited for a 33%/33%/17%/17% capacity split.

UNIT	DIMENSION Y	DIMENSION X	OPERATING CORNER WEIGHTS			
			A	B	C	D
09DK-074---	3'-6 1/2" [1080 mm]	4'-8 11/16" [1440 mm]	618 lb [280 kg]	526 lb [239 kg]	486 lb [220 kg]	571 lb [259 kg]
09DK-074-C	3'-6 13/16" [1087 mm]	4'-9 3/8" [1458 mm]	722 lb [328 kg]	630 lb [286 kg]	589 lb [267 kg]	675 lb [306 kg]
09DK-084---	3'-6 5/8" [1082 mm]	4'-9 1/8" [1450 mm]	673 lb [305 kg]	581 lb [264 kg]	541 lb [245 kg]	626 lb [284 kg]
09DK-084-C	3'-7" [1092 mm]	4'-10 1/8" [1476 mm]	843 lb [382 kg]	751 lb [341 kg]	709 lb [322 kg]	796 lb [361 kg]

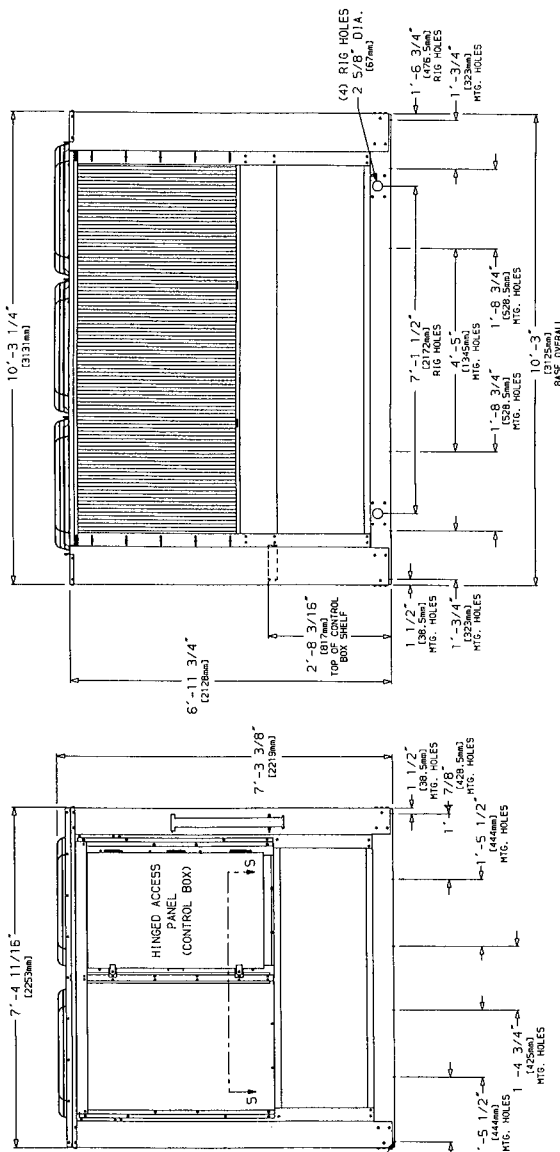
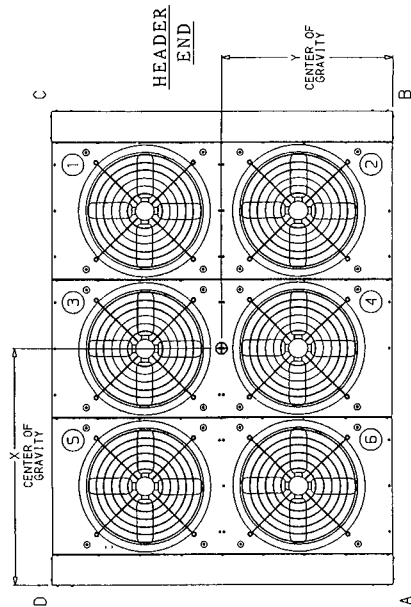
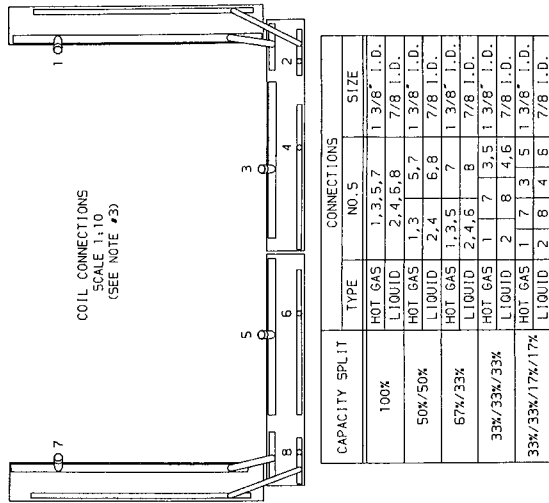
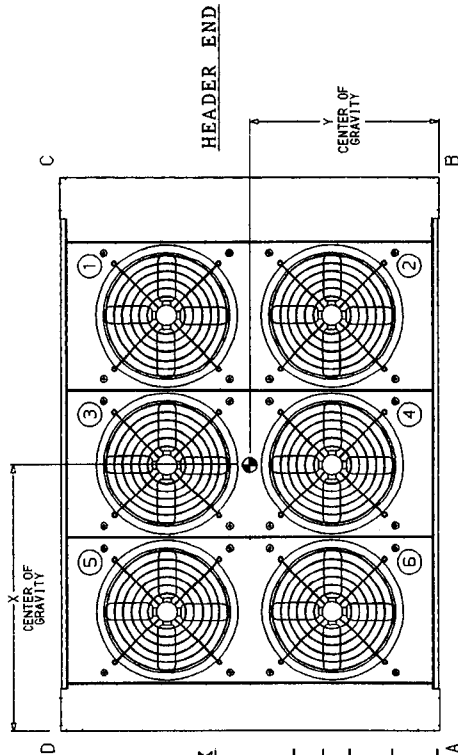

Fig. 3 — Dimensions, 074 and 084 Units

NOTES.

- The approximate operating weight of the unit is:
 09DK-094--- → 2850 lb [1294 kg]
 09DK-094-C → 3560 lb [1615 kg]
- Unit must have clearances for airflow as follows:
 Top — Do not restrict in any way.
 Ends — 5 ft [1524 mm]
 Sides — 6 ft [1829 mm]
- Mounting holes may be used to mount unit to concrete pad. They are not recommended for mounting unit to spring isolators. If spring isolators are used, a perimeter support channel between the unit and the isolators is recommended.



UNIT	DIMENSION Y	DIMENSION X	OPERATING CORNER WEIGHTS			
			A	B	C	D
09DK-094---	5'-2 7/8" [1597 mm]	3'-9 3/16" [1148 mm]	769 lb [349 kg]	676 lb [307 kg]	658 lb [299 kg]	747 lb [339 kg]
09DK-094-C	5'-2 7/8" [1597 mm]	3'-9 3/16" [1148 mm]	960 lb [436 kg]	845 lb [383 kg]	821 lb [372 kg]	934 lb [424 kg]

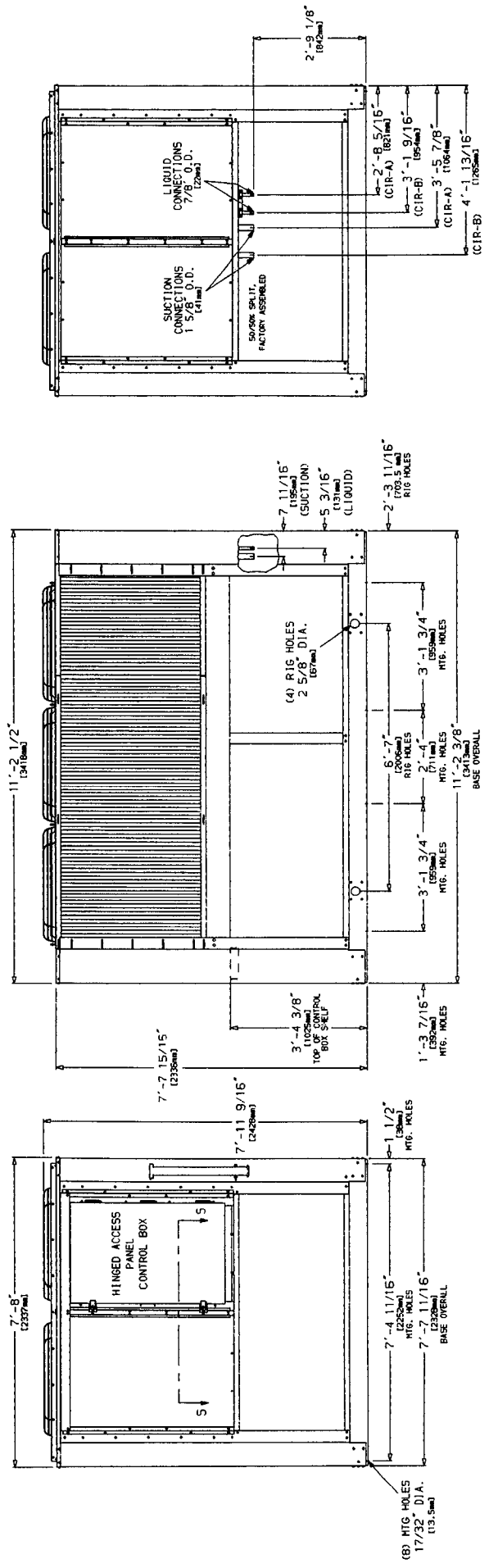

Fig. 4 — Dimensions; 094 Units

TUBING PACKAGE INSTALLATION — Before installing, inspect the package contents. If any parts are missing or damaged, file a claim with the shipping company and notify your Carrier representative. **A field supplied 3/8-in. conduit (Greenfield conduit recommended) is required according to UL/CSA (Underwriters' Laboratories/Canadian Standards Association) code for the FCPS field wiring. Field supplied 3/8-in. conduit connectors are required for connection to the junction box.**

100% Coil Circuiting Applications; 054, 064 Units

1. Piping — Refer to Fig. 10 and 14 for field piping details for 100% coil circuiting. Note that tubes 15 and 22 require cuts on the longer legs of the tubes. Two 7/8-in. OD tubes, approximately 3 in. (76.2 mm) long, must be cut from the remaining tubes (tubes 21, 23, or 25) and brazed between the tees (item 8) and coil header stubs. The remaining tubes are not used in this application and may be discarded.

2. Install Fan Cycle Pressure Switches and Clamps — Braze 2 valve core bodies (item 5) to designated hole locations on tubes 19 and 22. Insert valve cores (item 6), into valve core bodies by threading into place and tightening to 1.5 to 3 in.-lb (169.5 to 339 mN-m). Install FCPS1 and FCPS2 (item 7) at designated locations on tubes 19 and 22. Cut the 3/8-in. field-supplied FCPS conduit to fit between each FCPS location and the junction box on the unit. Figure 13 shows a typical installation of the conduit. Feed FCPS wires through each conduit and secure at the switch using each conduit connector. See Fig. 15. Secure the conduit at the junction box with 3/8-in. field-supplied conduit connectors. Wire FCPS1 and FCPS2 according to Fig. 16. Clamp hot gas line, tube 27, at the location specified in Fig. 14 using the 1 5/8-in. clamp (item 4) and the 2 screws supplied. Clamp the liquid line, tube 24, using the 1 1/8-in. clamp (item 2) and the 2 screws provided.

50/50% Coil Circuiting Applications; 054 and 064 units

1. Piping — Refer to Fig. 10 and 17 for field piping details for 50/50% coil circuiting. Note that tubes 21 and 22 require cuts on the longer legs of the tubes. Two 7/8-in. OD tubes, approximately 3 in. (72.6 mm) long, must be cut from the remaining tubes (21, 25, 26, or 29) and brazed between the tees (item 8) and coil header stubs. The remaining tubes are not used in this application and may be discarded.

2. Install Fan Cycle Pressure Switches and Clamps — Braze 2 valve core bodies (item 5) to designated hole locations on tubes 19 and 22. Insert valve cores (item 6) into valve core bodies by threading into place and tightening to 1.5 to 3 in.-lb (169.5 to 339 mN-m). Install FCPS1 and FCPS2 (item 7) at designated locations on tubes 19 and 22. Cut the field-supplied 3/8-in. FCPS conduit to fit between each FCPS location and the junction box on the unit. Figure 13 shows a typical installation of the conduit. Feed FCPS wires through each conduit and secure at the switch using each conduit connector. See Fig. 15. Secure the conduit at the junction box with 3/8-in. field-supplied conduit connectors. Wire FCPS1 and FCPS2 according to Fig. 16. Clamp hot gas lines, tube 15, at the location specified in Fig. 17 using the two 1 3/8-in. clamps (item 3) and 4 screws provided. Clamp the liquid lines, tubes 21 and 23, using the two 7/8-in. clamps (item 1) and the 4 screws provided.

66/34% Coil Circuiting Applications; 054 and 064 Units

NOTE: To operate the 054 and 064 condenser units with 66/34% coil circuiting, an accessory fan control kit is required. Refer to fan control kit installation instructions for more information.

1. Piping — Refer to Fig. 10 and 18 for field piping details for 66/34% coil circuiting. Note that tube 16 requires cuts on the longer leg of the tube. Tube 16 is used in the two specified locations. A 7/8-in. OD tube, approximately 3 in. (72.6 mm) long, must be cut from the remaining tubes (23 or 26) and brazed between the tee (item 8) and coil header stub. The remaining tubes are not used in this application and may be discarded.

2. Install Fan-Cycle Pressure Switches and Clamps — Braze 3 valve core bodies (item 5) to designated hole locations on tubes 19, 21, and 22. Insert valve cores (item 6) into valve core bodies by threading into place and tightening to 1.5 to 3 in.-lb (169.5 to 339 mN-m). Note that the accessory fan control kit is required for this coil circuiting. An extra FCPS and valve assembly is provided with the kit. Install FCPS1, FCPS2, and FCPS4 (item 7) at designated locations on tubes 19, 21, and 22. Cut the field-supplied 3/8-in. FCPS conduit to fit between each FCPS location and the junction box on the unit. See Fig. 13 for typical conduit installation. Feed FCPS wires through each conduit and secure at the switch using each conduit connector. See Fig. 15. Secure the conduit at the junction box with 3/8-in. field-supplied conduit connectors. Wire FCPS1, FCPS2, and FCPS4 according to Fig. 16. Note that FCPS2 and FCPS4 are wired in parallel. Fan 4 is shared by the 34% and 66% refrigeration circuit; the fan switches on if either circuit requires it. At the location specified in Fig. 18, clamp hot gas lines, tubes 15 and 30, using a 1 3/8-in. clamp (item 3) and a 1 1/8-in. clamp (item 2) with the 4 screws supplied. Clamp the liquid lines, tubes 21 and 25, with 7/8-in. clamps (item 1) and 4 screws provided.

100% Coil Circuiting Applications; 074 Units

1. Piping — Refer to Fig. 10 and 19 for field piping details for 100% coil circuiting. Note that tube 16 requires a cut on the longer leg of the tube. Two 7/8-in. OD tubes approximately 3 in. (72.6 mm) long, must be cut from the remaining tubes (22 or 23) and brazed between the tees (item 9) and coil header stubs. The remaining tubes are not used and may be discarded.

2. Install Fan Cycle Pressure Switches and Clamps — Braze 2 valve core bodies (item 6) to designated hole locations on tubes 20 and 24. Insert valve cores (item 7) into valve core bodies by threading into place and tightening to 1.5 to 3 in.-lb (169 to 339 mN-m). Install FCPS1 and FCPS2 (item 8) at designated locations on tubes 20 and 24. Cut the 3/8-in. field-supplied FCPS conduit to fit between each FCPS location and the junction box on the unit. See Fig. 13 for typical conduit installation. Feed FCPS wires through each conduit and secure at the switch using each conduit connector. See Fig. 15. Secure the conduit at the junction box with 3/8-in. field-supplied conduit connectors. Wire FCPS1 and FCPS2 according to Fig. 20. Clamp hot gas line, tube 28, using 2 1/8-in. clamp (item 5) at the location specified in Fig. 19 with the 2 screws supplied. Clamp the liquid line, tube 25, using 1 1/8-in. clamp (item 2) and the 2 screws provided.

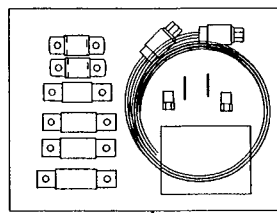
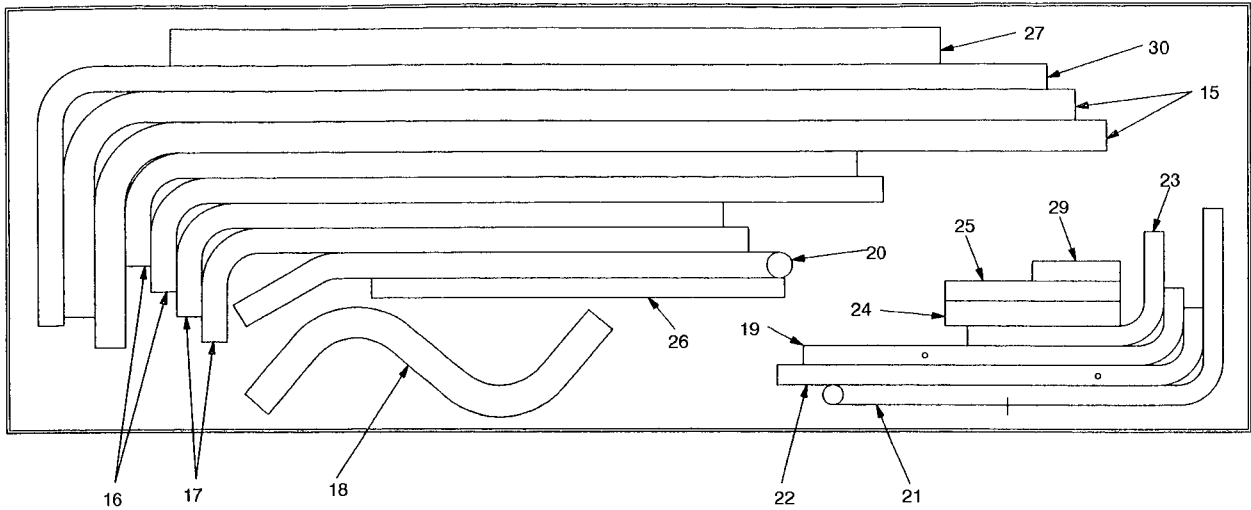

1(2), 2, 3(2), 4, 5(2), 6(2), 7(2), 28

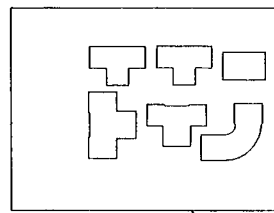

8(2), 9, 10, 11, 12

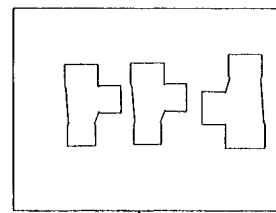

13(2), 14

ITEM	QUANTITY	NAME	DESCRIPTION
1	2	Tube Clamp	7/8 in.
2	1	Tube Clamp	1 1/8 in.
3	2	Tube Clamp	1 3/8 in.
4	1	Tube Clamp	1 5/8 in.
5	2	Valve Body	1/4 in. male flare fitting
6	2	Valve Core	—
7	2	Switch	Fan cycle pressure switch
8	2	Tee	7/8 in. x 7/8 in. x 7/8 in.
9	1	Tee	1 1/8 in. x 1 1/8 in. x 1 1/8 in.
10	1	Tee	7/8 in. x 7/8 in. x 1 1/8 in.
11	1	Solder Coupling	1 1/8 in.
12	1	Elbow, 90 Degree	1 1/8 in.
13	2	Tee	1 3/8 in. x 1 1/8 in. x 1 1/8 in.
14	1	Tee	1 5/8 in. x 1 3/8 in. x 1 3/8 in.
15	2	Discharge Tube	1 3/8 in. OD x 44 23/32 in. L x 10 1/16 in. W
16	2	Discharge Tube	1 1/8 in. OD x 32 11/32 in. L x 5 1/16 in. W
17	2	Discharge Tube	1 1/8 in. OD x 24 5/32 in. L x 5 1/16 in. W
18	1	Discharge Tube	1 3/8 in. OD
19	1	Liquid Tube	7/8 in. OD x 16 13/16 in. L x 3 7/16 in. W
20	1	Discharge Tube	1 1/8 in. OD x 24 1/2 in. L
21	1	Liquid Tube	7/8 in. OD x 17 11/16 in. L
22	1	Liquid Tube	7/8 in. OD x 18 13/16 in. L x 3 7/16 in. W
23	1	Liquid Tube	7/8 in. OD x 8 11/16 in. L x 5 1/16 in. W
24	1	Straight Tube	1 1/8 in. OD x 7 3/4 in. L
25	1	Straight Tube	7/8 in. OD x 7 3/4 in. L
26	1	Straight Tube	7/8 in. OD x 18 1/4 in. L
27	1	Straight Tube	1 5/8 in. OD x 34 in. L
28	8	Screw	1/4 - 14 x 5/8 in. long
29	1	Straight Tube	7/8 in. OD x 3 7/8 in. long
30	1	Discharge Tube	1 1/8 in. OD x 44 19/32 in. L x 11 9/16 in. W

Fig. 5 – 09DK054,064 Tubing Package Contents

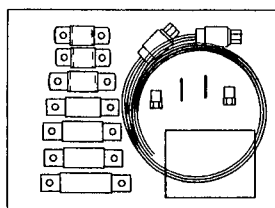
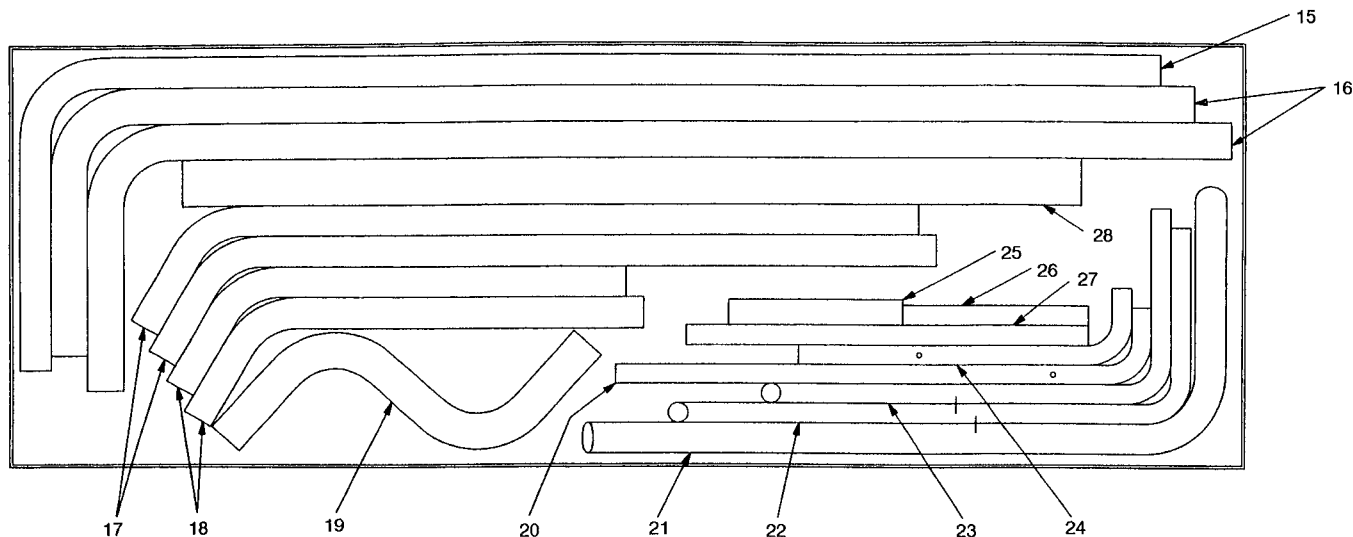

1(2), 2, 3, 4(2), 5, 6(2), 7(2), 8(2), 29

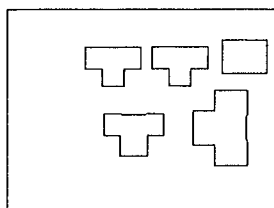

9(2), 10, 11, 12

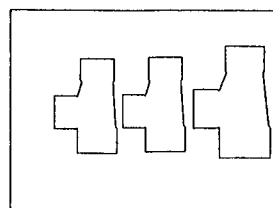

13(2), 14

ITEM	QUANTITY	NAME	DESCRIPTION
1	2	Tube Clamp	7/8 in.
2	1	Tube Clamp	1 1/8 in.
3	1	Tube Clamp	1 3/8 in.
4	2	Tube Clamp	1 5/8 in.
5	1	Tube Clamp	2 1/8 in.
6	2	Valve Body	1/4 in. male flare fitting
7	2	Valve Core	—
8	2	Switch	Fan cycle pressure switch
9	2	Tee	7/8 in. x 7/8 in. x 7/8 in.
10	1	Coupling	1 3/8 in. x 1 3/8 in.
11	1	Tee	7/8 in. x 7/8 in. x 1 1/8 in.
12	1	Tee	1 3/8 in. x 1 3/8 in. x 1 3/8 in.
13	2	Tee	1 5/8 in. x 1 3/8 in. x 1 3/8 in.
14	1	Tee	2 1/8 in. x 1 5/8 in. x 1 5/8 in.
15	1	Discharge Tube	1 3/8 in. OD x 50 25/32 in. L x 14 1/8 in. W
16	2	Discharge Tube	1 5/8 in. OD x 50 29/32 in. L x 12 1/16 in. W
17	2	Discharge Tube	1 3/8 in. OD x 34 1/2 in. L x 4 3/4 in. W
18	2	Discharge Tube	1 3/8 in. OD x 19 7/8 in. L x 4 3/4 in. W
19	1	Discharge Tube	1 5/8 in. OD
20	1	Liquid Tube	7/8 in. OD x 23 13/16 in. L x 3 7/16 in. W
21	1	Discharge Tube	1 3/8 in. OD x 28 3/8 in. L
22	1	Liquid Tube	7/8 in. OD x 23 1/4 in. L (074 Units only)
23	1	Liquid Tube	7/8 in. OD x 18 1/4 in. L
24	1	Liquid Tube	7/8 in. OD x 14 13/16 in. L x 3 7/16 in. W
25	1	Straight Tube	1 1/8 in. OD x 7 3/4 in. L
26	1	Straight Tube	7/8 in. OD x 8 1/4 in. L
27	1	Straight Tube	7/8 in. OD x 17 7/8 in. L
28	1	Straight Tube	2 1/8 in. OD x 40 in. L
29	8	Screw	1/4 in.-14 x 5/8 in. long

Fig. 6 – 09DK074,084 Tubing Package Contents

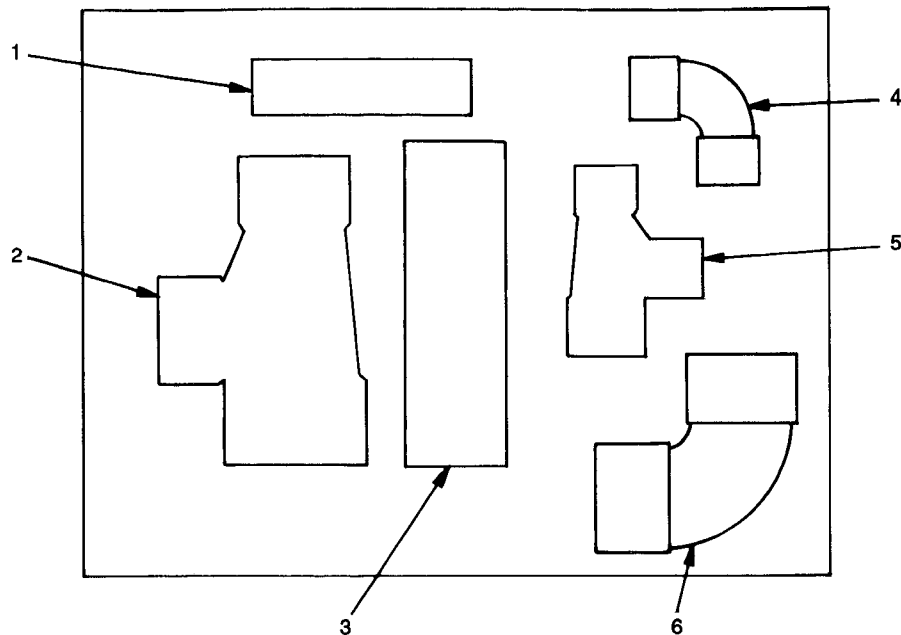

ITEM	QUANTITY	NAME	DESCRIPTION
1	1	Liquid Tube	7/8 in. x 3 1/2 in. L
2	1	Tee	2 1/8 in. x 1 5/8 in x 1 5/8 in
3	1	Discharge Tube	1 5/8 in. OD x 5 1/4 in. L
4	1	Elbow	7/8 in. x 7/8 in.
5	1	Tee	1 1/8 in x 7/8 in x 7/8 in.
6	1	Elbow	1 5/8 in. x 1 5/8 in

Fig. 7 – 09DK094 Tubing Package Contents

50/50% Coil Circuiting Applications; 074 Units

1. *Piping* — Refer to Fig. 10 and 21 for field piping details for 50/50% coil circuiting. Note that tube 23 requires a cut, located exactly at the location of the hole in the tube. Tube 23 is used in the two locations specified. Two 7/8-in. OD tubes, approximately 3 in. (72.6 mm) long, must be cut from the remaining tubes (22, 26, or 27) and brazed between the tees (item 9) and coil header stubs. The remaining tubes are not used in this application and may be discarded.

2. *Install Fan Cycle Pressure Switches and Clamps* — Braze 2 valve core bodies (item 6) to designated hole locations on tubes 20 and 24. Insert valve cores (item 7) into valve core bodies by threading into place and tightening to 1.5 to 3 in.-lb (169.5 to 339 mN-m). Install FCPS1 and FCPS2 (item 8) at designated location on tubes 20 and 24. Cut the 3/8-in. field-supplied FCPS conduit to fit between each FCPS location and the junction box on the unit. See Fig. 13 for typical conduit installation. Feed FCPS wires through each conduit and secure at the switch using each conduit connector. See Fig. 15. Secure the conduit at the junction box with 3/8-in. field-supplied conduit connectors. Wire FCPS1 and FCPS2 according to Fig. 20. Clamp hot gas line, tube 16, at the location specified in Fig. 21 using two 1 5/8-in. clamps (item 4) and 4 screws supplied. Clamp the liquid lines, tube 23, using the two 7/8-in. clamps (item 1) and the 4 screws provided.

68/32% Coil Circuiting Applications; 074 Units

NOTE: To operate the 074 condenser units with 68/32% coil circuiting, an accessory fan control kit is required. See accessory installation instructions for more information.

1. *Piping* — Refer to Fig. 10 and 22 for field piping details for 68/32% coil circuiting. Note that tubes 17 and 20 require cuts on the longer legs of the tubes. Tube 17 is used in the two locations specified. Also, a 7/8-in. OD tube, approximately 3 in. (72.6 mm) long, must be cut from the remaining tubes (23 or 27) and brazed between the tee (item 9) and coil header stub. The remaining tubes are not used in this application and may be discarded.

2. *Install Fan Cycle Pressure Switches and Clamps* — Braze 3 core bodies (item 6) to designated hole locations on tubes 20, 22, and 24. Insert valve cores (item 7) into valve core bodies by threading into place and tightening to 1.5 to 3 in.-lb (169.5 to 339 mN-m). Note that the accessory fan control kit is required for this coil circuiting. An extra FCPS and valve assembly is provided with the kit. Install FCPS1, FCPS2, and FCPS4 (item 8) at designated locations on tubes 20, 22, and 24. Cut the 3/8-in. field-supplied FCPS conduit to fit between each FCPS location and the junction box on the unit. See Fig. 13 for typical conduit installation. Feed FCPS wires through each conduit and secure at the switch using each conduit connector. See Fig. 15. Secure the conduit at the junction box with 3/8-in. field-supplied conduit connectors. Wire FCPS1, FCPS2 and FCPS4 according to Fig. 20. Note that FCPS2 and FCPS4 are wired in parallel. Fan 4 is shared by the 32% and 68% refrigeration circuit; the fan switches on if either circuit requires it. At the location specified in Fig. 22, clamp hot gas lines, tube 15 with a 1 3/8 in. clamp (item 3) and tube 16 with a 1 5/8 in. clamp (item 4) with the 4 screws supplied. Clamp the liquid lines, tube 22, with a 7/8 in. clamp (item 1) and tube 25 with a 1 1/8 in. clamp (item 2) with the 4 screws supplied.

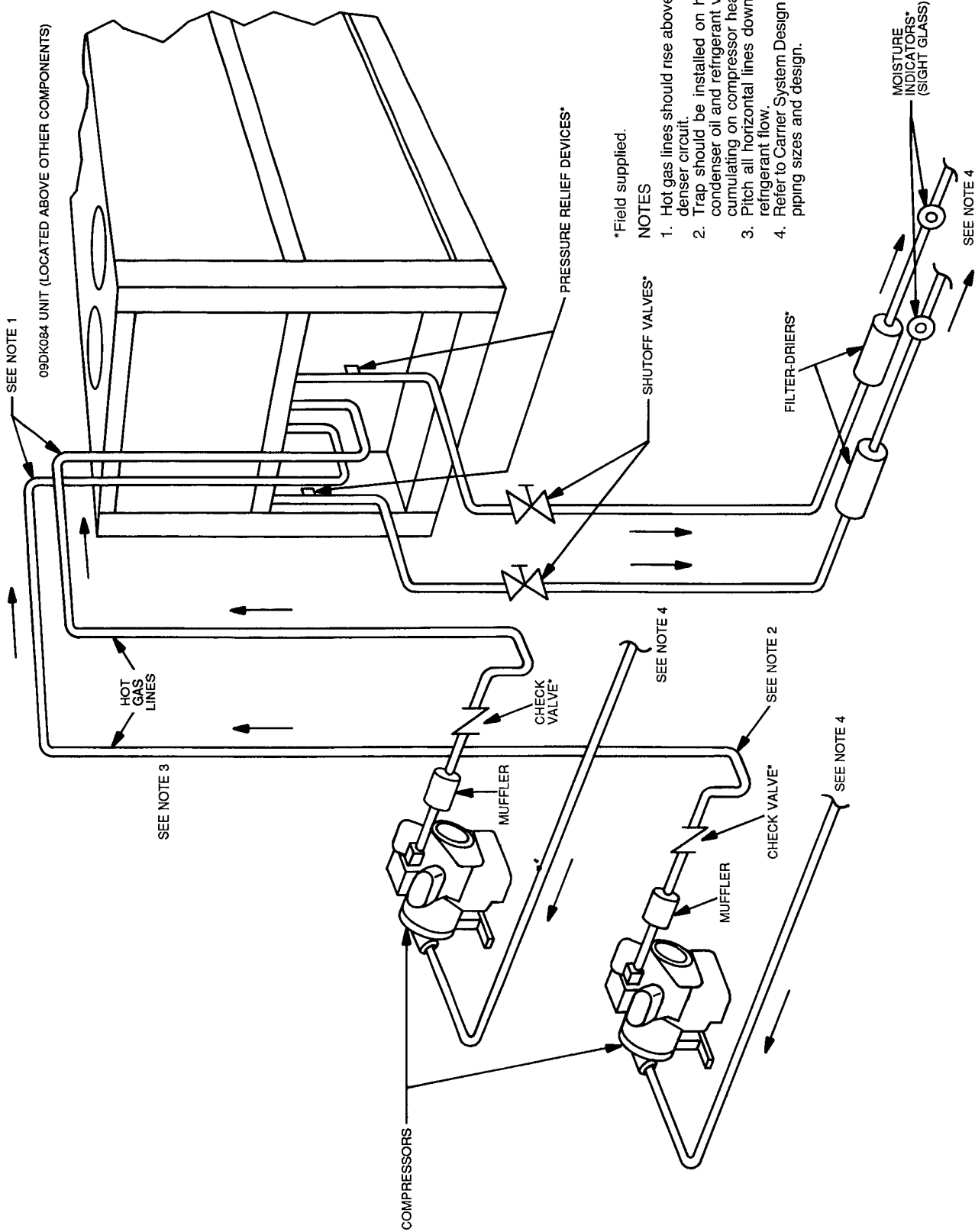

*Field supplied.

NOTES

1. Hot gas lines should rise above refrigerant level in condenser circuit.
2. Trap should be installed on hot gas lines to prevent cumulating oil and refrigerant vapor migration from off cycle.
3. Pitch all horizontal lines downward in the direction of refrigerant flow.
4. Refer to Carrier System Design Manual, part 3 for proper piping sizes and design.

Fig. 8 — Typical Piping for 09DK Condenser With a Dual Split System

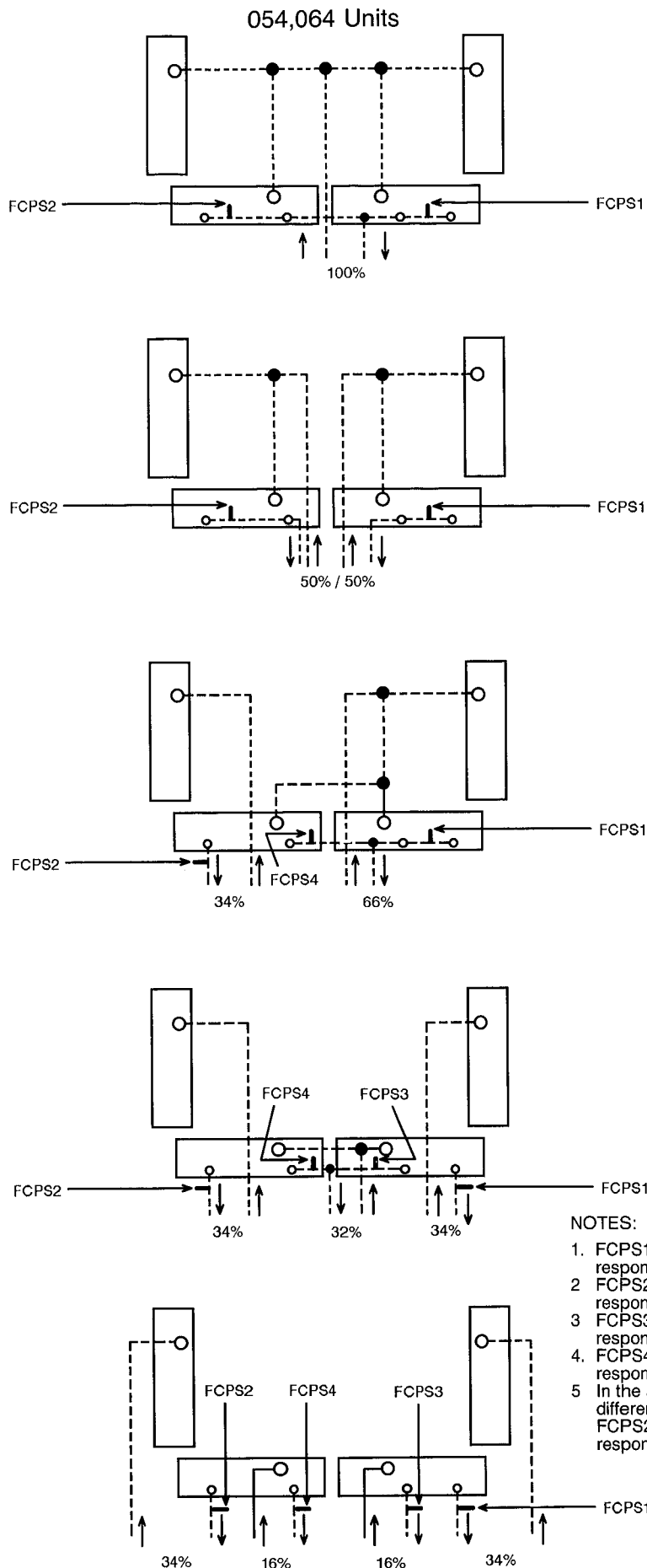

NOTES:

1. FCPS1 = Fan cycle pressure switch 1 cycles fan 3 in response to condensing pressure.
2. FCPS2 = Fan cycle pressure switch 2 cycles fan 4 in response to condensing pressure.
3. FCPS3 = Fan cycle pressure switch 3 cycles fan 3 in response to condensing pressure.
4. FCPS4 = Fan cycle pressure switch 4 cycles fan 4 in response to condensing pressure.
5. In the above applications where a fan is being shared by two different refrigeration circuits, the FCPSs (FCPS1 and 3 or FCPS2 and 4) are in parallel so that the fan switches on in response to the condensing pressure in either circuit.

Fig. 9 — Typical Field Piping Arrangements

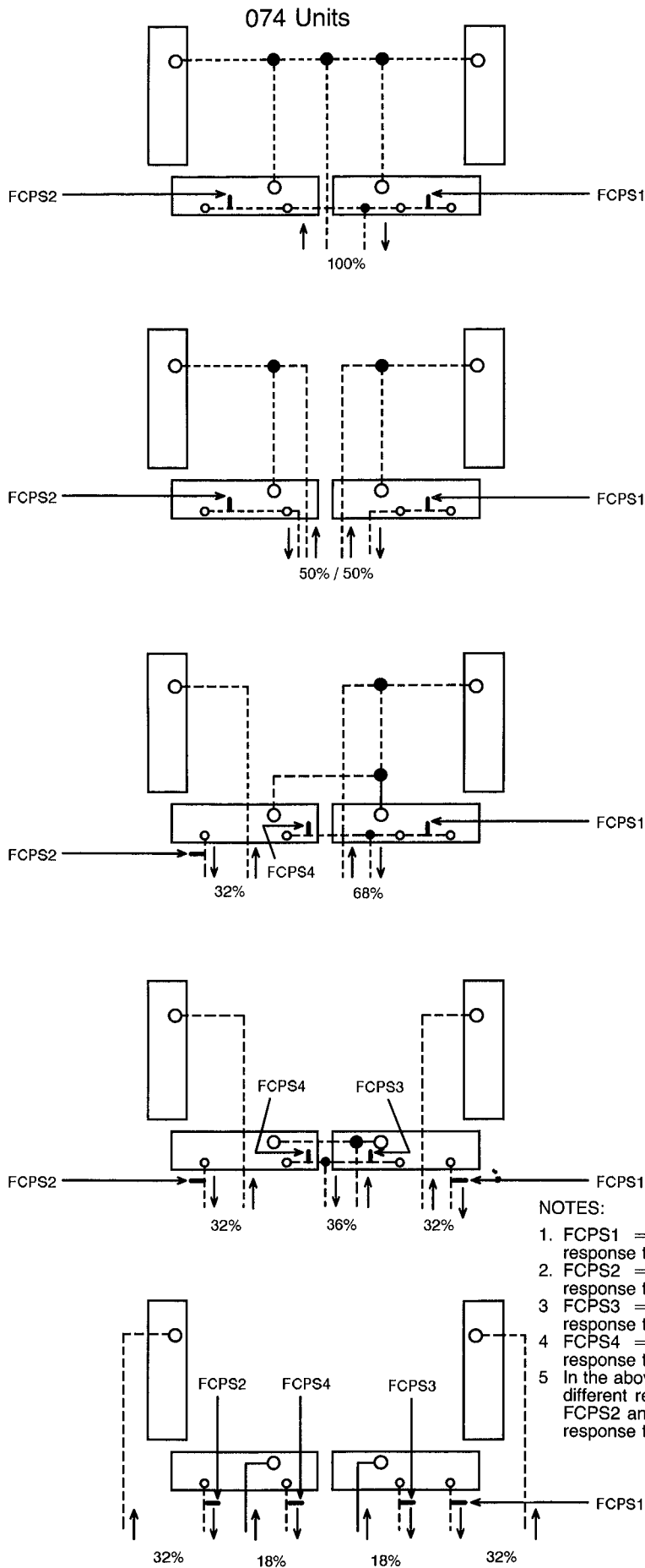

FCPS – Fan Cycle Pressure Switch

Fig. 9 – Typical Field Piping Arrangements (cont)

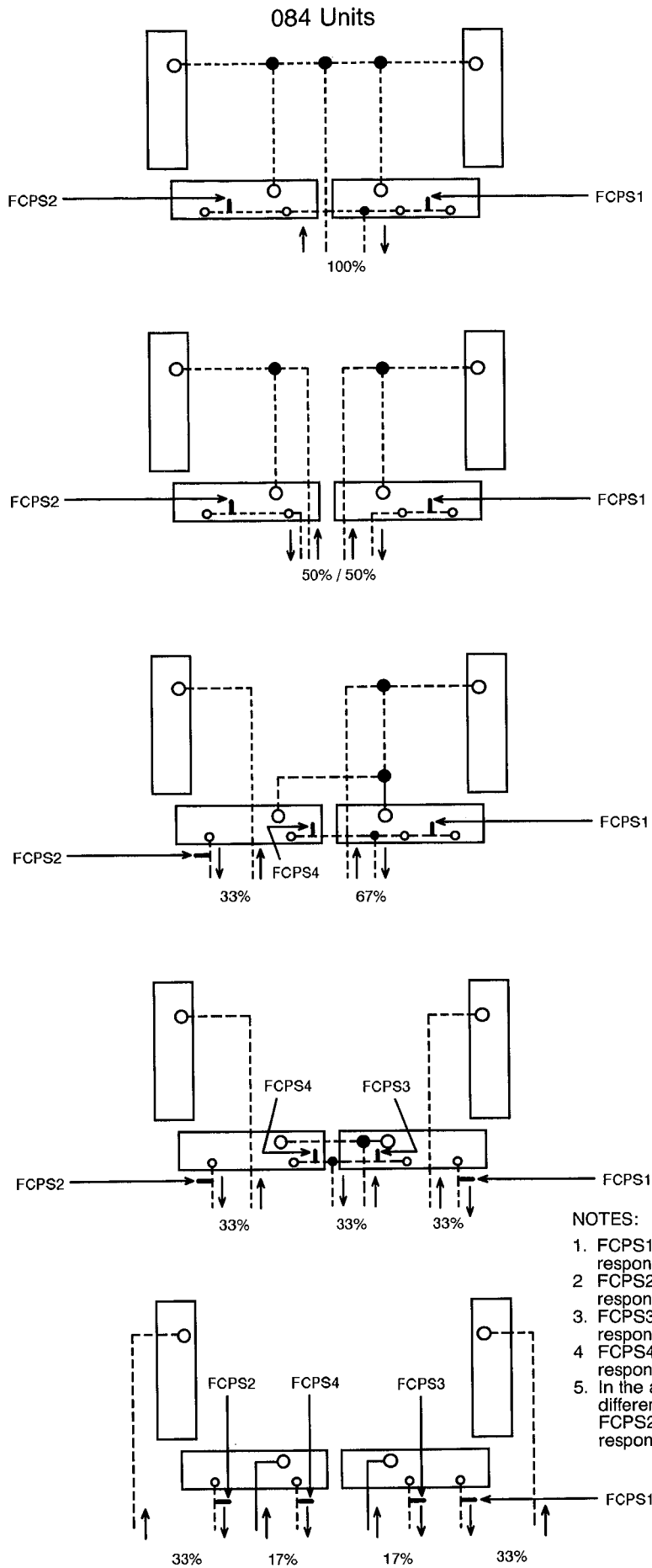

NOTES:

1. FCPS1 = Fan cycle pressure switch 1 cycles fan 3 in response to condensing pressure.
2. FCPS2 = Fan cycle pressure switch 2 cycles fan 4 in response to condensing pressure
3. FCPS3 = Fan cycle pressure switch 3 cycles fan 3 in response to condensing pressure
4. FCPS4 = Fan cycle pressure switch 4 cycles fan 4 in response to condensing pressure.
5. In the above applications where a fan is being shared by two different refrigeration circuits, the FCPSs (FCPS1 and 3 or FCPS2 and 4) are in parallel so that the fan switches on in response to the condensing pressure in either circuit.

FCPS – Fan Cycle Pressure Switch

Fig. 9 – Typical Field Piping Arrangements (cont)

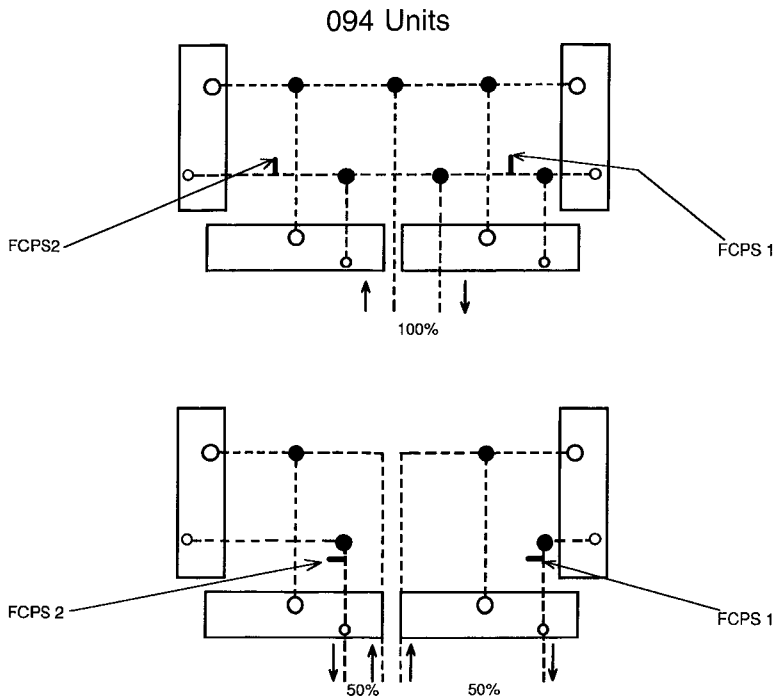

NOTES:

- 1 FCPS1 = Fan cycle pressure switch 1 cycles fan 3 in response to condensing pressure.
- 2 FCPS2 = Fan cycle pressure switch 2 cycles fan 4 in response to condensing pressure

Fig. 9 – Typical Field Piping Arrangements (cont)

100% Coil Circuiting Applications; 084 Units

1. *Piping* — Refer to Fig. 10 and 23 for field piping details for 100% coil circuiting. Note that tubes 16 and 20 require cuts on the longer legs of the tubes. Two 7/8-in. OD tubes, approximately 3 in. (72.6 mm) long, must be cut from the remaining tubes (22 or 23) and brazed between the tees (item 9) and coil header stubs. The remaining tubes are not used in this application and may be discarded.

2. *Install Fan Cycle Pressure Switches and Clamps* — Braze 2 valve core bodies to designated hole locations on tubes 20 and 24. Insert valve cores into valve core bodies by threading into place and tightening to 1.5 to 3 in.-lb (169.5 to 339 mN-m). Install FCPS1 and FCPS2 at designated locations on tubes 20 and 24. Cut the 3/8-in. field-supplied FCPS conduit to fit between each FCPS location and the junction box on the unit. See Fig. 13 for typical conduit installation. Feed FCPS wires through each conduit and secure at the switch using each conduit connector. See Fig. 15. Secure the conduit at the junction box with 3/8-in. field-supplied conduit connectors. Wire FCPS1 and FCPS2 according to Fig. 20. At the location specified in Fig. 23, clamp hot gas line, tube 28, using 2 1/8-in. clamp and 2 screws provided. Clamp the liquid line, tube 25, using 1 1/8-in. clamp and 2 screws provided.

50/50% Coil Circuiting Applications; 084 Units

1. *Piping* — Refer to Fig. 10 and 24 for field piping details for 50/50% coil circuiting. Note that tube 20 requires a cut on the longer leg of the tube. Tube 23 requires a cut located exactly at the location of the hole in the tube, and is used at the two locations specified. Two 7/8-in. OD tubes, approximately 3 in. (72.6 mm) long, must be cut from the remaining tubes (22, 26, and 27) and brazed between the tees (item 9) and coil header stubs. The remaining tubes are not used in this application and may be discarded.

2. *Install Fan Cycle Pressure Switches and Clamps* — Braze 2 valve core bodies (item 6) to designated hole locations on tubes 20 and 24. Insert valve cores (item 7) into valve core bodies by threading into place and tightening to 1.5 to 3 in.-lb (169.5 to 339 mN-m). Install FCPS1 and FCPS2 (item 8) at designated locations on tubes 20 and 24. Cut the 3/8-in. field-supplied FCPS conduit to fit between each FCPS location and the junction box on the unit. See Fig. 13 for typical conduit installation. Feed FCPS wires through each conduit and secure at the switch using each conduit connector. See Fig. 15. Secure the conduit at the junction box with 3/8-in. field-supplied conduit connectors. Wire FCPS1 and FCPS2 according to Fig. 20. At the location specified in Fig. 24, clamp hot gas line, tube 16, using two 1 5/8-in. clamps and 4 screws provided. Clamp the liquid lines, tubes 23, using two 7/8-in. clamps (item 1) and 4 screws provided.

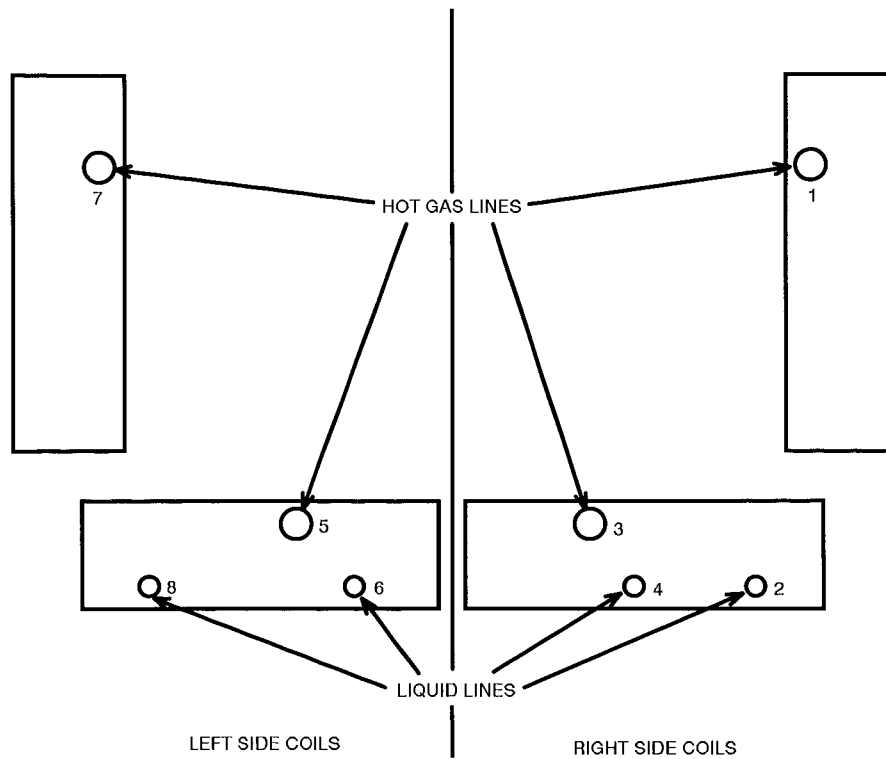

054,064

PERCENT CAPACITY SPLIT	LINE TYPE	COIL CONNECTION NUMBER	COIL CONNECTION in.-ODM*	TUBING CONNECTION in.-ODM†
100	Hot Gas Liquid	1,3,5,7 2,4,6,8	1 1/8 7/8	1 5/8 1 1/8
50/50	Hot Gas Liquid	1,3/5,7 2,4/6,8	1 1/8 7/8	1 3/8 7/8
66/34	Hot Gas Liquid	1,3,5/7 2,4,6/8	1 1/8 7/8	1 3/8 7/8
34/34/32	Hot Gas Liquid	1/7/3,5 2/8/4,6	1 1/8 7/8	(3) 1 1/8 (3) 7/8
34/34/16/16	Hot Gas Liquid	1/7/3/5 2/8/4/6	1 1/8 7/8	— —

*Connection sizes reflect size of each coil header nozzle

†A tubing package is factory supplied to facilitate field piping installation for the 100, 50/50 and 66/34% capacity split applications See Fig 5

074

PERCENT CAPACITY SPLIT	LINE TYPE	COIL CONNECTION NUMBER	COIL CONNECTION in.-ODM*	TUBING CONNECTION in.-ODM†
100	Hot Gas Liquid	1,3,5,7 2,4,6,8	1 3/8 7/8	2 1/8 1 1/8
50/50	Hot Gas Liquid	1,3/5,7 2,4/6,8	1 3/8 7/8	1 5/8 7/8
68/32	Hot Gas Liquid	1,3,5/7 2,4,6/8	1 3/8 7/8	1 5/8 7/8
32/32/36	Hot Gas Liquid	1/7/3,5 2/8/4,6	1 3/8 7/8	(3) 1 3/8 (3) 7/8
32/32/18/18	Hot Gas Liquid	1/7/3/5 2/8/4/6	1 3/8 7/8	— —

*Connection sizes reflect size of each coil header nozzle

†A tubing package is factory supplied to facilitate field piping installation for the 100, 50/50 and 68/32% capacity split applications. See Fig 6.

084

PERCENT CAPACITY SPLIT	LINE TYPE	COIL CONNECTION NUMBER	COIL CONNECTION in.-ODM*	TUBING CONNECTION in.-ODM†
100	Hot Gas Liquid	1,3,5,7 2,4,6,8	1 3/8 7/8	2 1/8 1 1/8
50/50	Hot Gas Liquid	1,3/5,7 2,4/6,8	1 3/8 7/8	1 5/8 7/8
67/33	Hot Gas Liquid	1,3,5/7 2,4,6/8	1 3/8 7/8	1 5/8 1 1/8
33/33/33	Hot Gas Liquid	1/7/3,5 2/8/4,6	1 3/8 7/8	(3) 1 3/8 (3) 7/8
33/33/17/17	Hot Gas Liquid	1/7/3/5 2/8/4/6	1 3/8 7/8	— —

*Connection sizes reflect size of each coil header nozzle

†A tubing package is factory supplied to facilitate field piping installation for the 100, 50/50 and 67/33% capacity split applications See Fig 6

Fig. 10 – Coil Connection Data, 09DK054-084

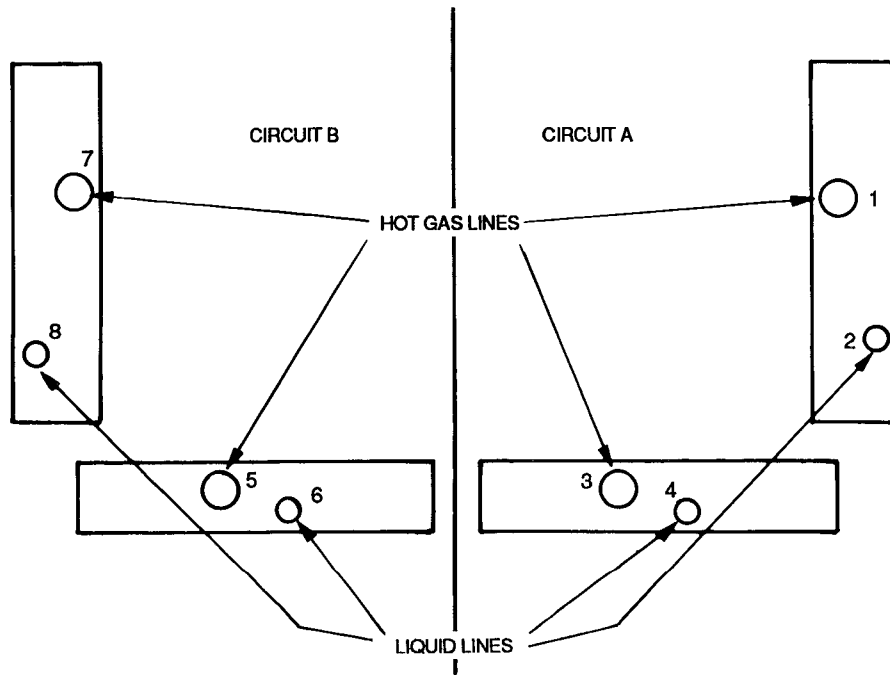

PERCENT CAPACITY SPLIT	LINE TYPE	COIL CONNECTION NUMBER	COIL CONNECTION in. — ODM*	TUBING CONNECTION in. — ODM†
100	Hot Gas Liquid	1,3,5,7 2,4,6,8	1 ⁵ / ₈ 7 ⁷ / ₈	2 ¹ / ₈ 1 ¹ / ₈
50/50	Hot Gas Liquid	1,3/5,7 2,4/6,8	1 ⁵ / ₈ 7 ⁷ / ₈	1 ⁵ / ₈ /1 ⁵ / ₈ 7 ⁷ / ₈ /7 ⁷ / ₈

*Connection sizes reflect size of each coil header nozzle.

†A tubing package is factory supplied to facilitate field piping installation for 100% capacity split applications. See Fig. 7.

Fig. 11 — Coil Connection Data, 09DK094

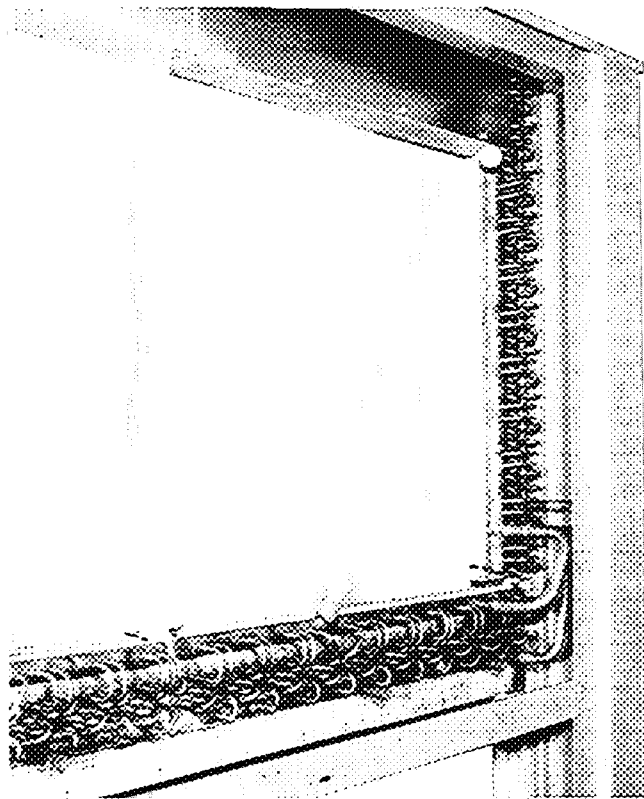

Fig. 12 — Typical Factory-Supplied Coil Circuiting, 09DK054-094 Units (084 Shown)

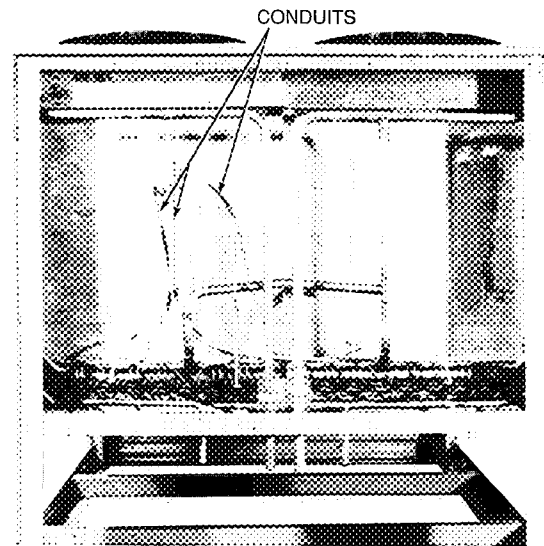

Fig. 13 — Typical Coil Circuiting for 09DK054-094 Units (67/33% Split Option; 084 Unit Shown)

67/33% Coil Circuiting Applications; 084 Units

NOTE: To operate 084 condenser units with 67/33% coil circuiting, an accessory fan control kit is required. See accessory installation instructions for more information.

1. *Piping* — Refer to Fig. 10 and 25 for field piping details for 67/33% coil circuiting. Note that tubes 17 and 20 require cuts on the longer legs of the tubes. Tube 17 is used in the two locations specified. Also, a 7/8-in. OD tube, approximately 3 in. (72.6 mm) long must be cut from the remaining tubes (22 or 27) and brazed between the tee (item 9) and coil header stub. The remaining tubes are not used in this application and may be discarded.

2. *Install Fan Cycle Pressure Switches and Clamps* — Braze 3 valve core bodies (item 6) to designated hole locations on tubes 20, 23, and 24. Insert valve cores (item 7) into valve core bodies by threading into place and tightening to 1.5 to 3 in.-lb (169.5 to 339 mN-m). Note that the accessory fan control kit is required for this coil circuiting. An extra FCPS and valve assembly is provided with the kit. Install FCPS1, FCPS2, and FCPS4 (item 8) at designated locations on tubes 20, 23, and 24. Cut the 3/8-in. field-supplied FCPS conduit to fit between each FCPS location and the junction box on the unit. See Fig. 13 for typical conduit installation. Feed FCPS wires through each conduit and secure at the switch using each conduit connector. See Fig. 15. Secure the conduit at the junction box with 3/8-in. field-supplied conduit connector. Wire FCPS1, FCPS2, and FCPS4 according to Fig. 20. Note that FCPS2 and FCPS4 are wired in parallel. Fan 4 is shared by the 33% and 67% refrigeration circuit; the fan switches on if either circuit requires it. At the location specified in Fig. 25, clamp hot gas

lines, tube 15 with a 1 3/8-in. clamp (item 3) and tube 16 with a 1 5/8-in. clamp (item 4) with the 4 screws supplied. Clamp the liquid lines, tube 23 with a 7/8-in. clamp (item 1) and tube 25 with a 1 1/8-in. clamp (item 2) with 4 screws supplied.

100% Coil Circuiting Applications; 094 Units

Refer to Fig. 11 and 26 for field piping details for 100% coil circuiting. Braze the tees, pipe, and elbows to manifold the hot gas and suction tubes as shown in Fig. 26. The fan cycle pressure switches are factory supplied and installed.

50/50% Coil Circuiting Applications; 094 Units

Unit piping and fan cycle pressure switches are factory supplied and installed for 50/50% coil circuiting. No field modifications to coil circuiting are required. See Fig. 11 and 27 for piping details.

THREE AND FOUR COIL SPLIT, COIL CIRCUITING APPLICATIONS; 054-084 UNITS ONLY

NOTE: To operate 054-084 condenser units with the 3 and 4 coil split coil circuiting, the fan control kit is required. See accessory installation instructions for more information.

1. *Piping* — Piping is not provided in the tubing package for these coil circuiting options. Tubing is field fabricated and installed according to the coil circuiting shown in Fig. 9. For pipe sizing information, refer to Refrigerant Line Sizing, page 20. To secure the piping, it should be routed to the brackets supplied on the unit.

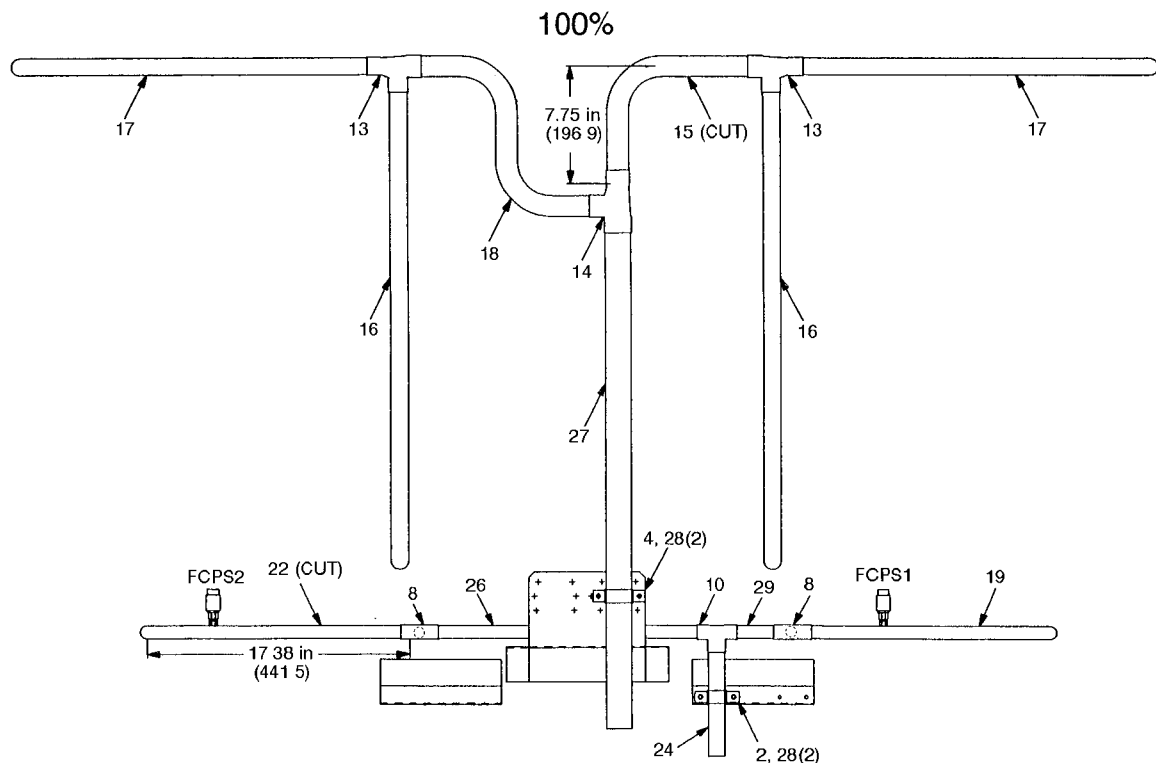

FCPS — Fan Cycle Pressure Switch

NOTES:

- 1 Dimensions in () are in millimeters.
- 2 See Fig. 5 for tubing package contents

Fig. 14 — 100% Coil Circuiting; 054 and 064 Units

2. *Install Fan Cycle Pressure Switches and Clamps* — Four FCPSs should be used. Locate holes, valve core assemblies, and FCPSs 1, 2, 3, and 4 at the specified locations. See Fig. 9. Insert valve cores into valve core bodies by threading into place and tightening to 1.5 to 3 in.-lb (169.5 to 339 mN-m). The additional two FCPSs and valve core assemblies are provided with the accessory fan control kit. Cut the 3/8-in. field-supplied FCPS conduit to fit between each FCPS location and the junction box on the unit. See Fig. 13 for typical conduit installation. Feed FCPS wires through each conduit and secure at the switch using each conduit connector. See Fig. 15. Secure the conduit at the junction box with 3/8-in. field-supplied conduit connectors. Wire the FCPSs according to Fig. 16 and 20. Note that FCPS2 and 4 and FCPS1 and 3 are wired in parallel. Fans 3 and 4 are shared by two different refrigeration circuits; the fan switches on if either circuit requires it. Clamp all lines to brackets supplied on the unit.

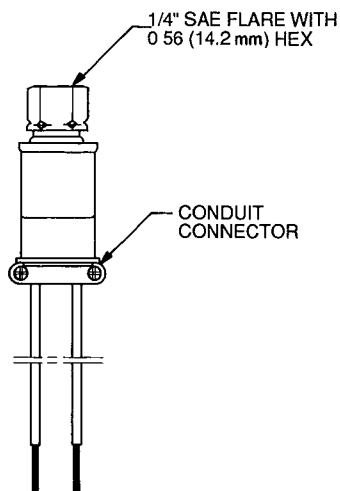

SAE — Society of Automotive Engineers

Fig. 15 — Fan Cycle Pressure Switch

REFRIGERANT LINE SIZING — Sizing depends on length of lines between various sections of the refrigerant system. See Fig. 10 for coil connection details. Consider the amount of liquid lift and drop in the system as well as proper compressor oil return. See Liquid Lift section for more information. Consult Carrier System Design Manual, Part 3, or Carrier E20-II Refrigerant Piping Computer Program for proper piping sizes and design.

LIQUID SHUTOFF VALVE AND SIGHT GLASS — A shutoff valve is not supplied with 09DK condensers. It is strongly recommended that a full line size liquid shutoff valve be field supplied near condenser to allow for servicing parts of the refrigerant circuit. A field-supplied moisture-indicating sight glass is recommended for use in charging and servicing the system. Refer to Fig. 8.

PRESSURE RELIEF — The ASHRAE Standard 15, Safety Code for Mechanical Refrigeration states: “Every refrigerating system shall be protected by a pressure relief device or some other means designed to safely relieve pressure due to fire or other abnormal conditions.” Since 09DK condensers do not have pressure relief devices, one must be field supplied and installed just before the liquid line service valve. (See Fig. 8.) When the split coil is used with multiple systems, each system must have its own pressure relief.

REFRIGERANT RECEIVER — A refrigerant receiver is *not* furnished with 09DK condensers and is *not* recommended for normal applications as its use will be detrimental to the desired effects of subcooling. However, if a particular application requires a receiver to increase refrigerant holding capacity of the condenser, a receiver can be used. Recommended receiver and valve installation and piping are shown in Fig. 28. When a receiver is to be used year-round, it should be installed indoors.

Procedure for Using the Refrigerant Receiver — (Fig. 28)

1. *During normal operation* — Valve A is open and valves B and C are closed. Receiver is isolated from the system.
2. *For servicing* — Valves A and C are closed and valve B is open. Run unit until all the refrigerant is in the receiver and then close valve B. Unit is now ready for servicing.
3. *To resume operation* — Leave valve A closed and open valves B and C. Run unit until the stored refrigerant is drawn into the system. To completely remove the refrigerant from the receiver, throttle valve B while noting condition of refrigerant in the liquid line sight glass; also, watch the suction pressure. A sudden surge of bubbles in the sight glass and a rapid decrease in suction pressure indicate that all the refrigerant has been withdrawn from the receiver. Immediately close valves B and C and then open valve A. The unit should now be ready for normal operation, with the receiver isolated from the system. *The system should be charged to a clear sight glass when under normal operation.*

LIQUID LIFT — Amount of liquid lift available before refrigerant flashing occurs depends on amount of liquid subcooling in the system

All 09DK condensers have positive subcooling when applied with optimum charge. With subcooling, it is possible to overcome an appreciable pressure drop and/or static head (due to elevation of the liquid metering device above the condenser).

- When 09DK condensers are applied with minimum charge, they do not provide positive subcooling. If subcooling is required, it must be obtained by external means such as a liquid suction interchanger.

The average amount of liquid lift available is shown in Table 3 for refrigerants R-22, R-502, and R-134A. Available subcooling is greatly reduced when R-12 and R-500 are used in these units. It is recommended that the evaporator be at the same level as the condenser, or lower.

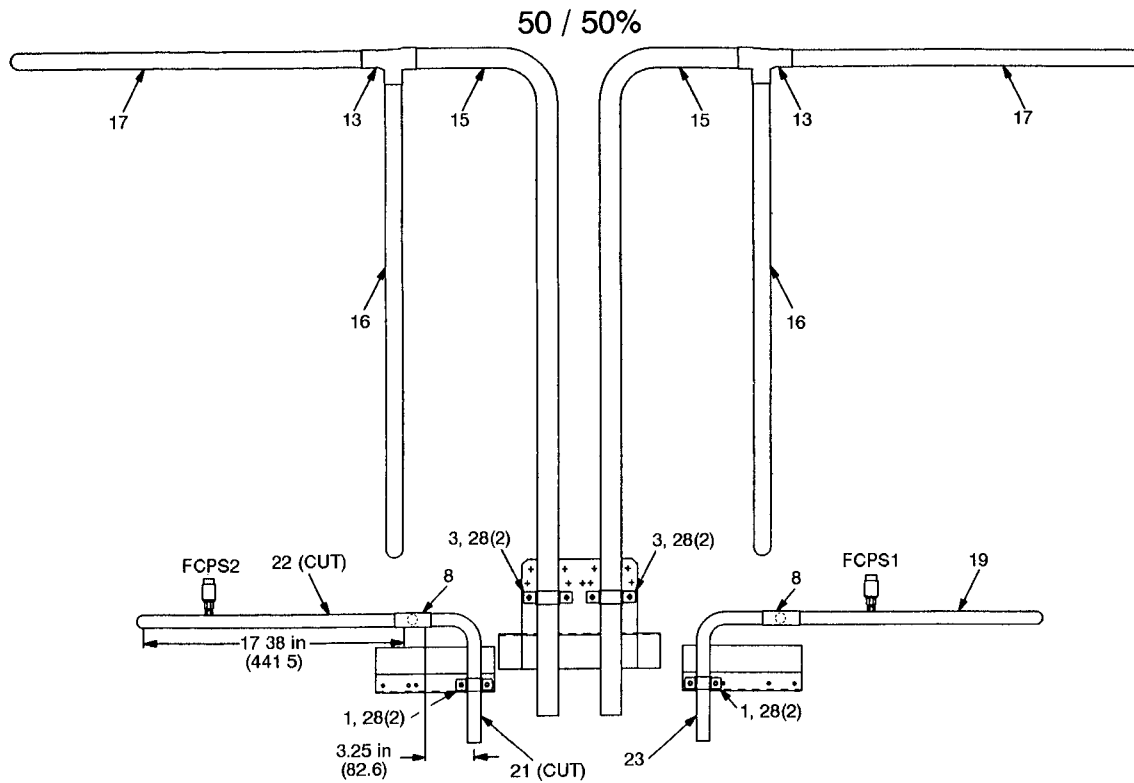

FCPS — Fan Cycle Pressure Switch

NOTES:

1. Dimensions in () are in millimeters.
2. See Fig. 5 for tubing package contents

Fig. 17 — 50/50% Coil Circuiting; 054 and 064 Units

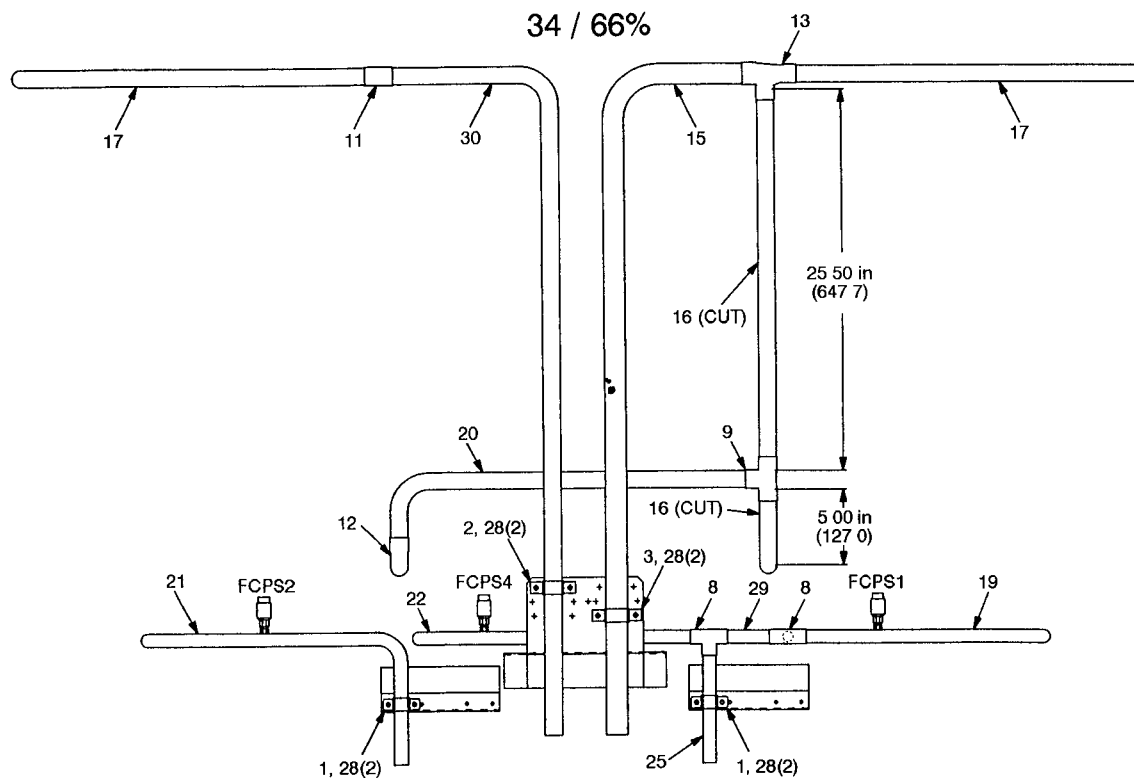

FCPS — Fan Cycle Pressure Switch

NOTES:

1. Dimensions in () are in millimeters.
2. See Fig. 5 for tubing package contents

Fig. 18 — 66/34% Coil Circuiting; 054 and 064 Units

Table 3 – Available Liquid Lift, Ft (m)

UNIT 09DK	REFRIGERANT					
	R-22		R-502		R-134A	
	Temperature Difference F (C)					
	20 (11.1)	30 (16.7)	20 (11.1)	30 (16.7)	20 (11.1)	30 (16.7)
054	60 (18.3)	50 (15.2)	60 (18.3)	44 (13.4)	29 (8.8)	26 (7.9)
064	41 (12.5)	31 (9.5)	41 (12.5)	25 (7.6)	20 (6.1)	6 (1.8)
074	44 (13.4)	34 (10.4)	44 (13.4)	28 (8.5)	18 (5.5)	7 (2.1)
084	51 (15.6)	41 (12.5)	51 (15.6)	35 (10.7)	22 (6.7)	10 (3.1)
094	41 (12.5)	31 (9.5)	41 (12.5)	25 (7.6)	18 (5.5)	1 (0.3)

NOTES:

1. The liquid lift data allows for a 7 psi (48 kpa) drop for liquid line accessories, and a 2° F (1.1° C), liquid line loss with maximum change
2. Temperature difference = Saturated condensing temperature (entering) – Entering-air temperature (dry bulb) in degree F (° C).
3. The liquid lift data is based on 15° F (8.3° C) subcooling, 95 F (35 C) entering-air temperature, and a 50/50% capacity split application. Subcooling based on condenser subcooling = Saturated condensing temperature entering – Actual temperature leaving the coil

Step 4 – Complete Electrical Connections

GENERAL — Verify nameplate electrical requirements match available power supply. Voltage at condenser must be within the minimum and maximum shown in Table 4 and phases must be balanced within 2%. Contact local power company for line voltage corrections. Never operate a motor where a phase imbalance in supply voltage is greater than 2%. Use the following formula to determine the percentage of voltage imbalance:

$$\% \text{ Voltage Imbalance} = 100 \times \frac{\text{max voltage deviation from average voltage}}{\text{average voltage}}$$

Example: Supply voltage is 240-3-60.

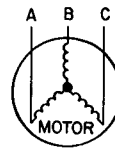

AB = 243 v
BC = 236 v
AC = 238 v

$$\begin{aligned} \text{Average Voltage} &= \frac{243 + 236 + 238}{3} \\ &= \frac{717}{3} \\ &= 239 \text{ v} \end{aligned}$$

Determine maximum deviation from average voltage:

(AB) 243 – 239 = 4 v
(BC) 239 – 236 = 3 v
(AC) 239 – 238 = 1 v

Maximum deviation is then 4 v. To determine the percentage of voltage imbalance:

$$\begin{aligned} \% \text{ Voltage Imbalance} &= 100 \times \frac{4}{239} \\ &= 1.7\% \end{aligned}$$

This amount of phase imbalance is satisfactory since it is below the allowable maximum of 2%.

IMPORTANT: If supply voltage phase imbalance is more than 2%, contact your local electric utility company immediately.

Condenser operation on improper line voltage or excessive phase imbalance may be considered abuse and any resulting damage may not be covered by Carrier warranty.

All wiring must be in accordance with local or NEC (National Electrical Code) regulations.

FIELD CONNECTIONS — Refer to Table 4 and Fig. 16, 20, and 29 for field wiring details.

Table 4 – 09DK Electrical Data

09DK	NAMEPLATE V-PH-HZ	SUPPLY VOLTAGE*		MCA	MOCP	NO. FANS	FAN MOTORS	
		Min	Max				Total Kw	(Fan no.) FLA for ea. fan
054,064								
-500	208/230-3-60	187	254	23.2	25	4	6.2	(1,2) 5.5 (3,4) 5.4
-600	460-3-60	414	508	11.7	15	4	6.2	(1,2) 2.8 (3,4) 2.7
-100	575-3-60	518	632	14.5	15	4	6.2	(1-4) 3.4
-200	380-3-60	342	418	16.6	20	4	6.2	(1-4) 3.9
-900	380/415-3-50	342	440	12.8	15	4	6.2	(1-4) 3.0
074,084,094								
-500	208/230-3-60	187	254	34.0	35	6	9.3	(1,2) 5.5 (3-6) 5.4
-600	460-3-60	414	508	17.1	20	6	9.3	(1,2) 2.8 (3-6) 2.7
-100	575-3-60	518	632	21.3	25	6	9.3	(1-6) 3.4
-200	380-3-60	342	418	24.4	25	6	9.3	(1-6) 3.9
-900	380/415-3-50	342	440	18.8	20	6	9.3	(1-6) 3.0

Control Circuit Information

09DK ALL UNITS	CONTROL POWER V-PH-HZ	SUPPLY VOLTAGE*		OVERCURRENT PROTECTION AMPS
-500	115-1-60	103	127	10
-600	115-1-60	103	127	10
-100	115-1-60	103	127	10
-200	230-1-60	207	253	10
-900	230-1-50	207	253	10

LEGEND

- FLA** – Full Load Amps
- MCA** – Minimum Circuit Amps; Used for wire sizing
(Complies with NEC Section 430-24)
- MOCP** – Maximum Overcurrent Protection
- NEC** – National Electrical Code

*Units are suitable for use on electrical systems where voltage supplied to the unit terminals is within listed minimum and maximum limits.

NOTES:

- 1 Maximum allowable phase imbalance: Voltage \pm 2%; Amps \pm 10%.
- 2 Maximum incoming wire size for power circuit is 2/0 max.
- 3 Control Circuit: Uses no. 8 screws for wire connections at the terminal block.
- 4 100 va is required for the 09DK054-094 control circuit

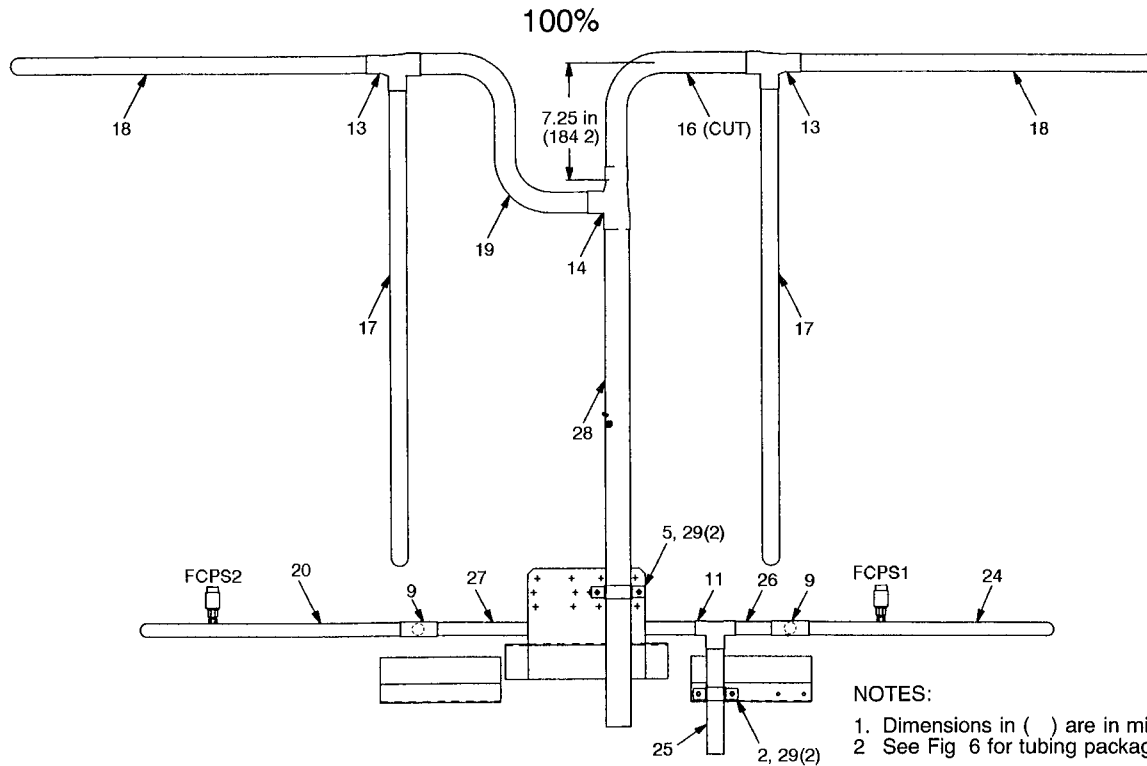

FCPS – Fan Cycle Pressure Switch

NOTES:

1. Dimensions in () are in millimeters.
2. See Fig 6 for tubing package contents

Fig. 19 – 100% Coil Circuiting; 074 Units

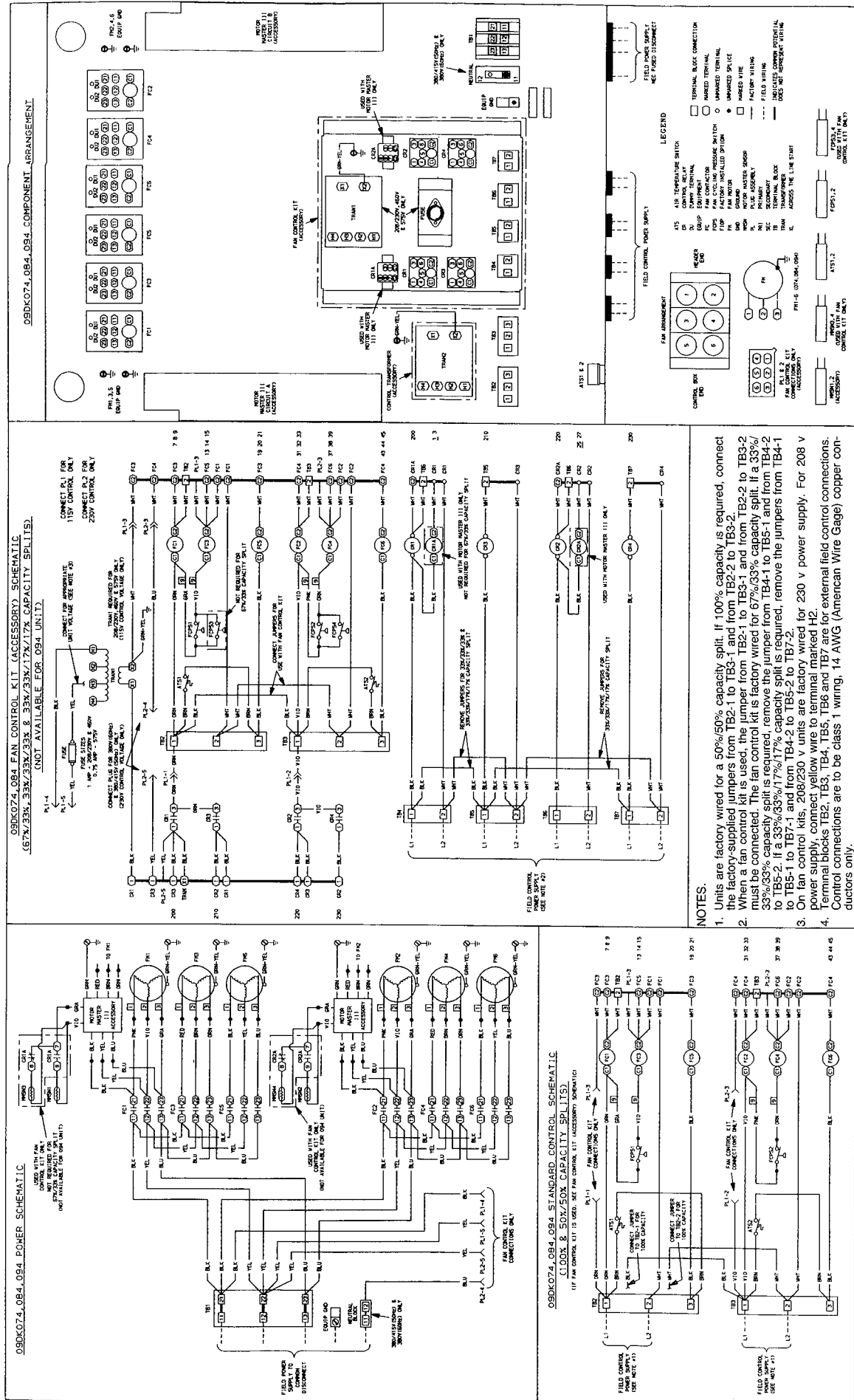
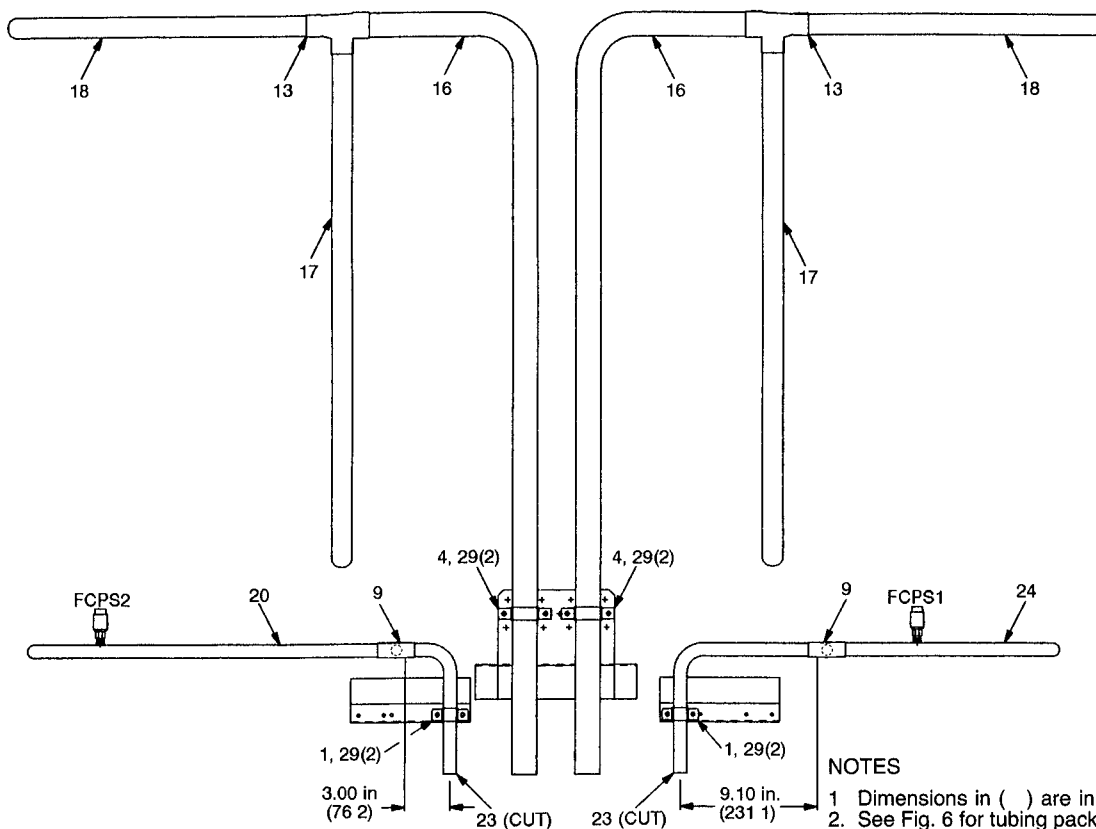

Fig. 20 — Wiring Diagram and Component Arrangement; 074-094 Units

50 / 50%



NOTES
 1 Dimensions in () are in millimeters.
 2. See Fig. 6 for tubing package contents.

FCPS — Fan Cycle Pressure Switch

Fig. 21 — 50/50% Coil Circuiting; 074 Units

32 / 68%

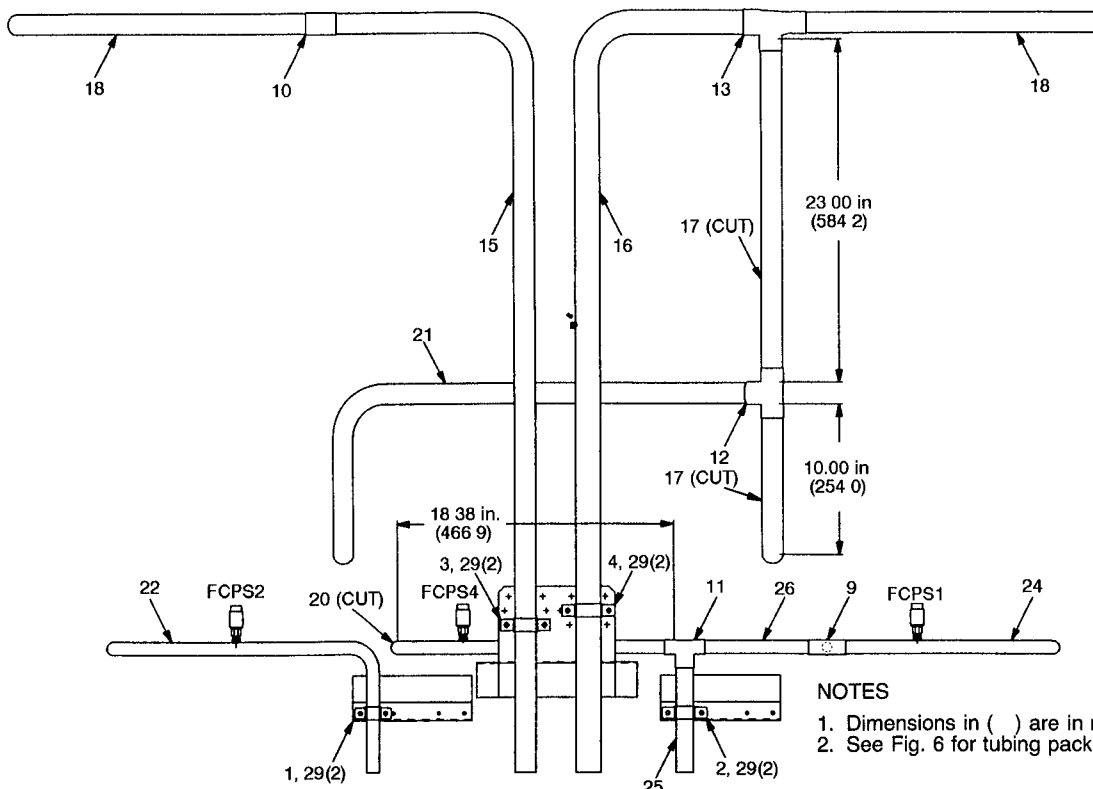

NOTES
 1. Dimensions in () are in millimeters
 2. See Fig. 6 for tubing package contents.

FCPS — Fan Cycle Pressure Switch

Fig. 22 — 68/32% Coil Circuiting; 074 Units

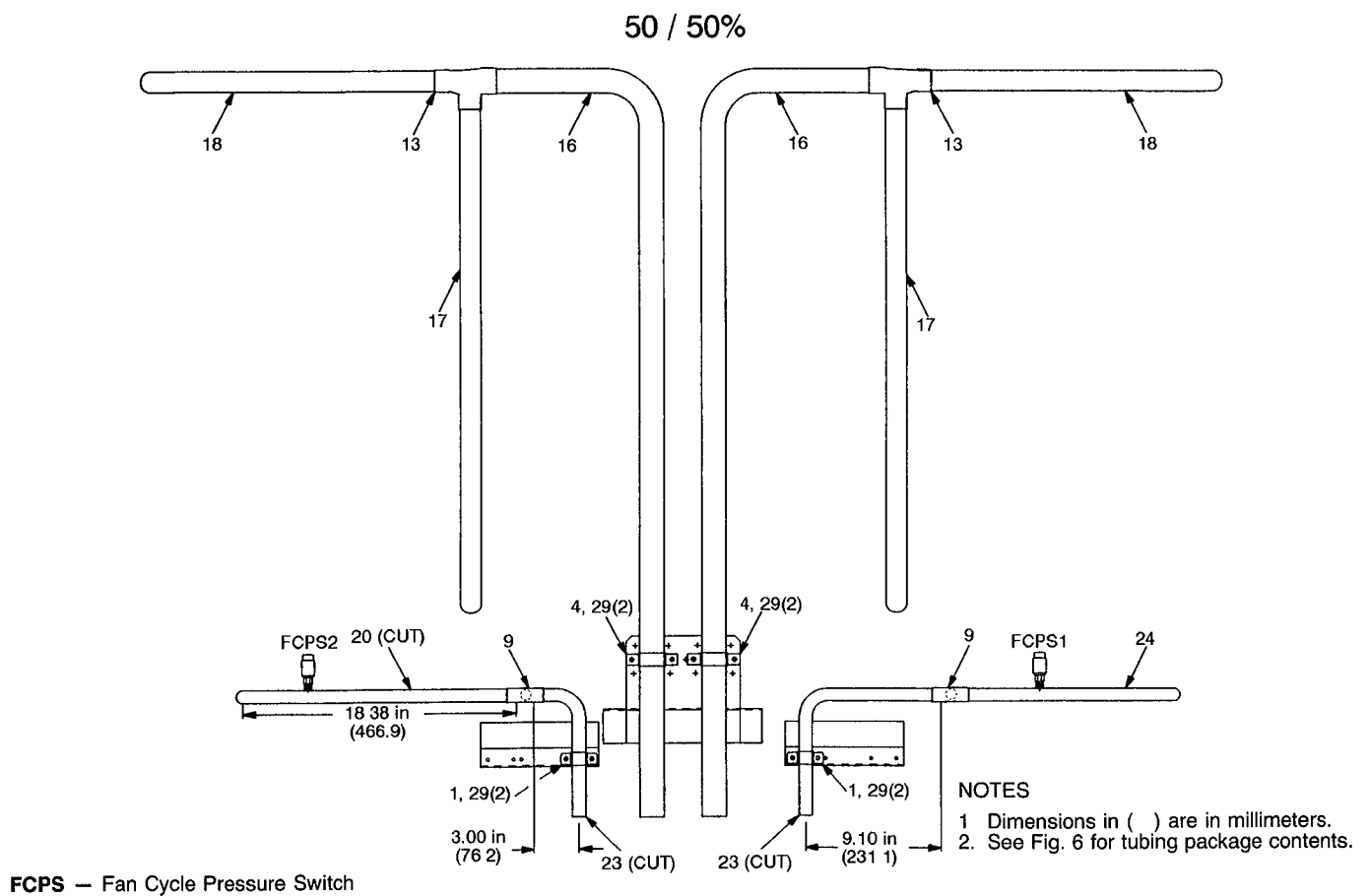
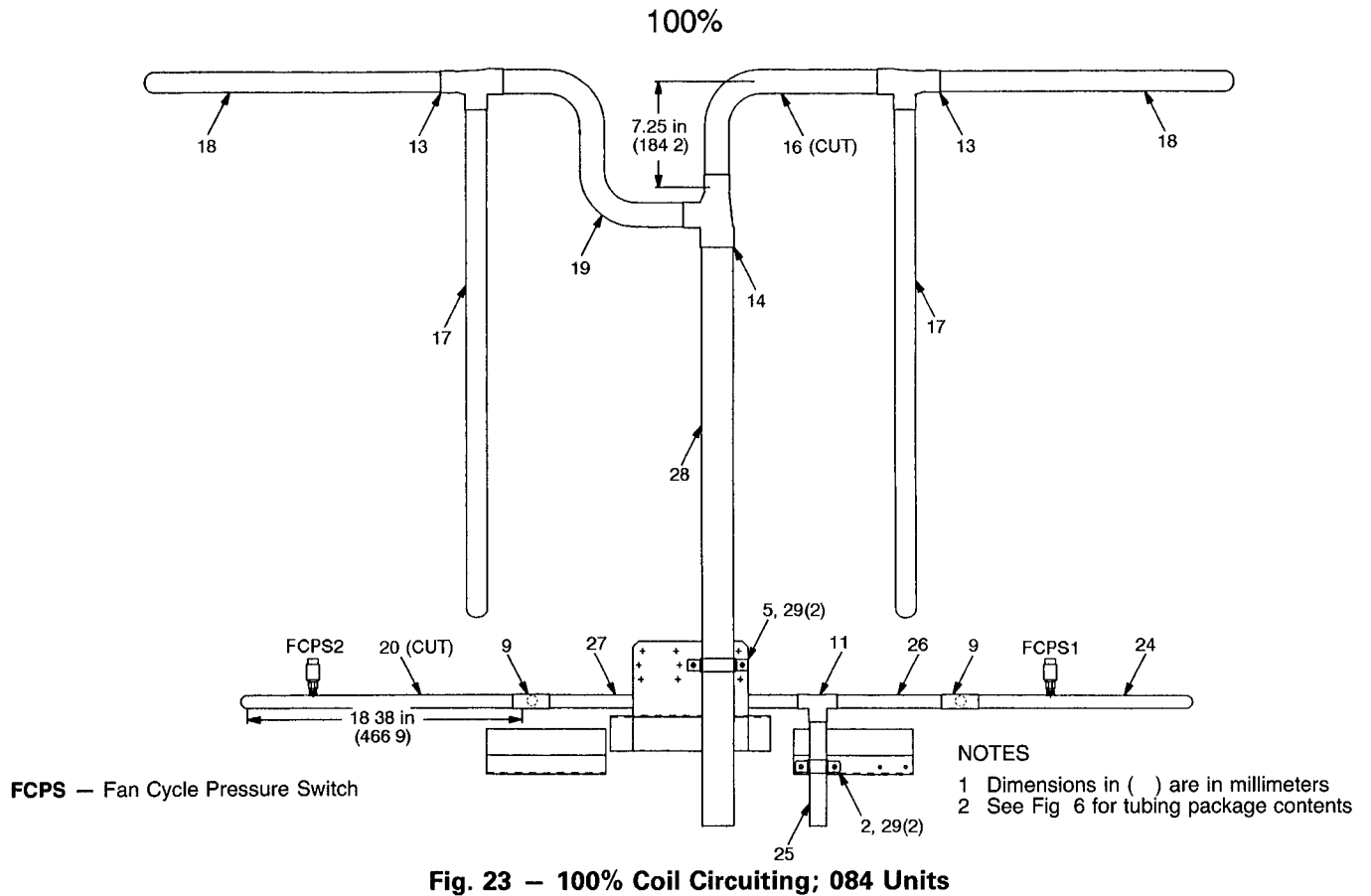

33 / 67%

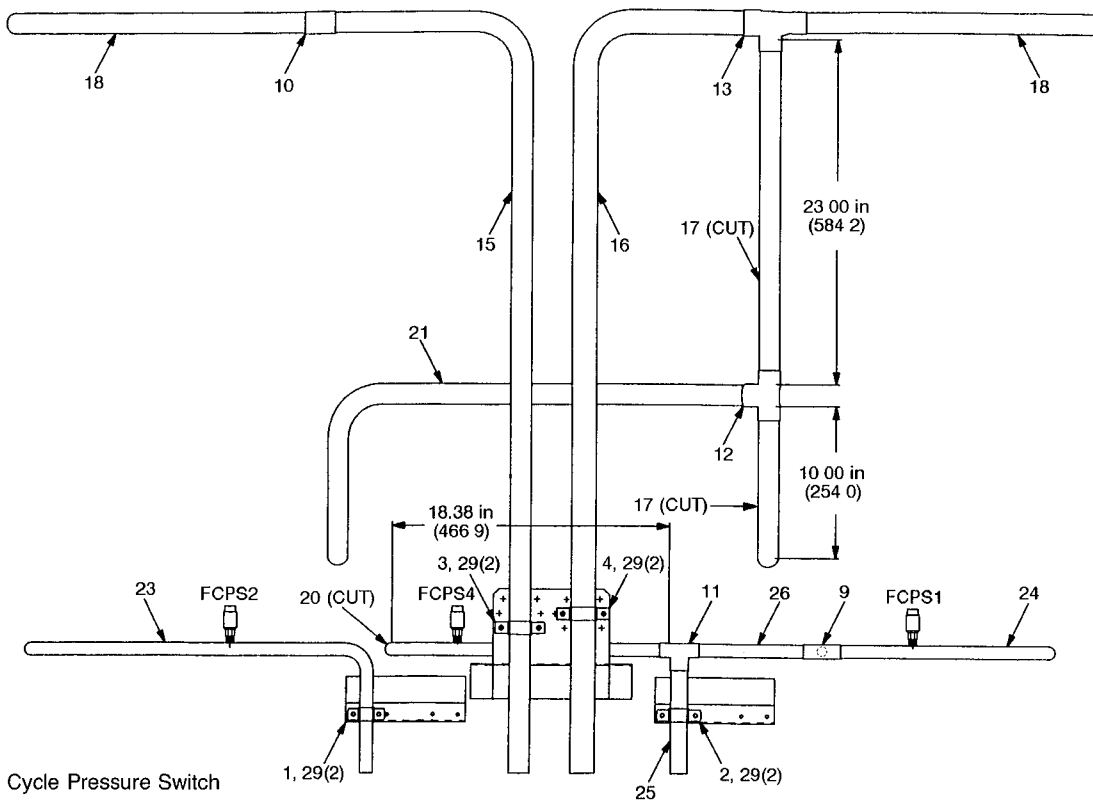

FCPS — Fan Cycle Pressure Switch

NOTES:

1. Dimensions in () are in millimeters.
2. See Fig. 6 for tubing package contents.

Fig. 25 — 67/33% Coil Circuiting; 084 Units

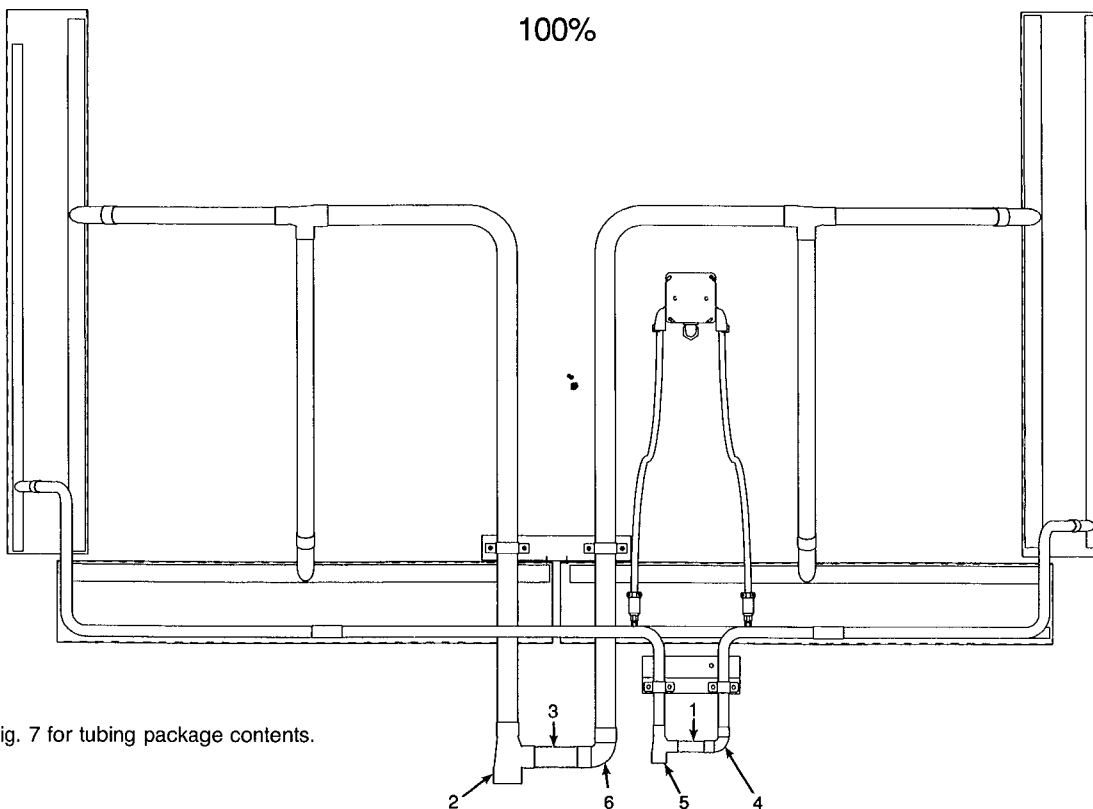

NOTE: See Fig. 7 for tubing package contents.

Fig. 26 — 100% Coil Circuiting; 094 Units

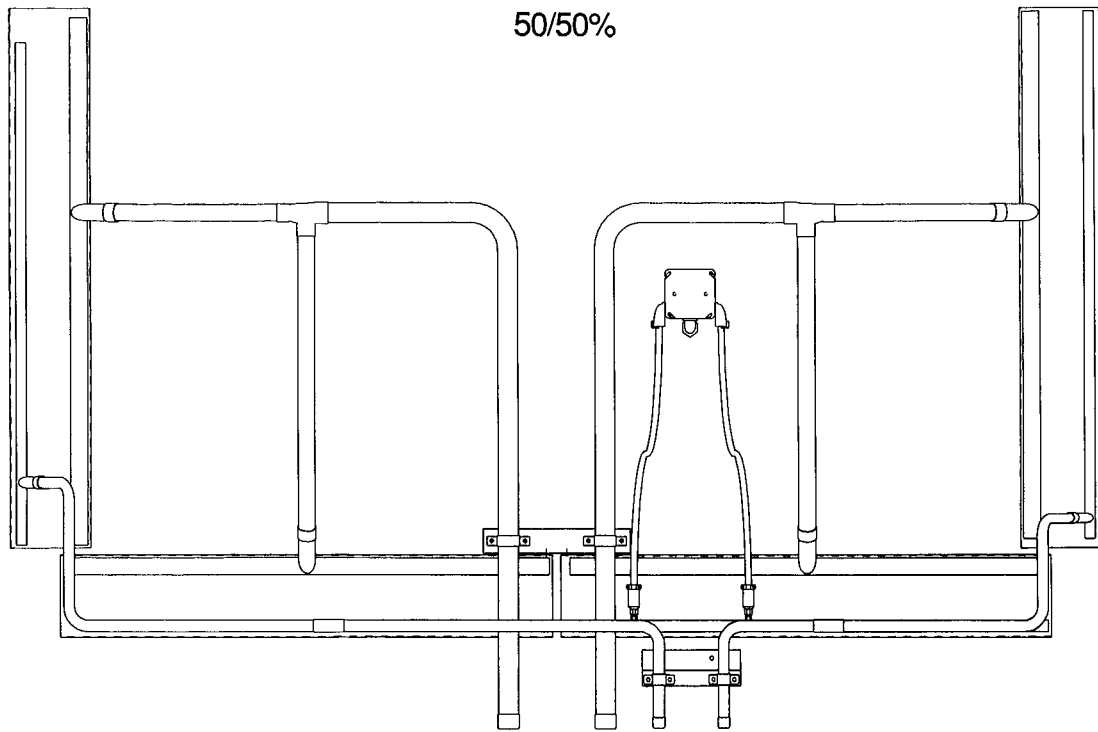
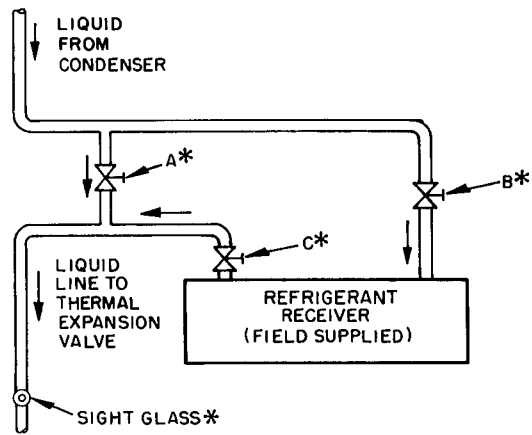

Fig. 27 – 50/50% Coil Circuiting; 094 Units



*Field-supplied service valves

- A – Bypass valve
- B – Receiver inlet valve
- C – Receiver outlet valve

Fig. 28 – Piping for Field-Supplied Receiver

NOTES:

1. Factory wiring is in accordance with National Electrical Code (NEC), field modifications or additions must be in compliance with all applicable codes.
2. Wiring for field power supply must be rated 75 C minimum. Use copper, copper-clad aluminum, or aluminum conductors. Maximum incoming wire size for each terminal block is 2/0.
3. Terminal blocks TB2, TB3, TB4, TB5, TB6, and TB7 are for external field control connections. Control connections are to be class 1 wiring.
4. Replacement of factory wires must be with type 105 C wire or its equivalent.
5. Units are factory wired for a 50%/50% capacity split. If 100% capacity is required, connect the factory-supplied jumpers from TB2-1 to TB3-1 and from TB2-2 to TB3-2. If jumpers are connected for 100% capacity, only one control power supply is required.
6. If a fan control kit is to be used, the jumper from TB2-1 to TB3-1 and the jumper from TB2-2 to TB3-2 must be connected. The fan control kit is factory wired for a 67%/33% capacity split. If a 33%/33%/33% capacity split is required, remove the jumper from TB4-1 to TB5-1 and from TB4-2 to TB5-2. If a 33%/33%/17%/17% capacity split is required, remove the jumpers from TB4-1 to TB5-1 to TB7-1 and from TB4-2 to TB5-2 to TB7-2.

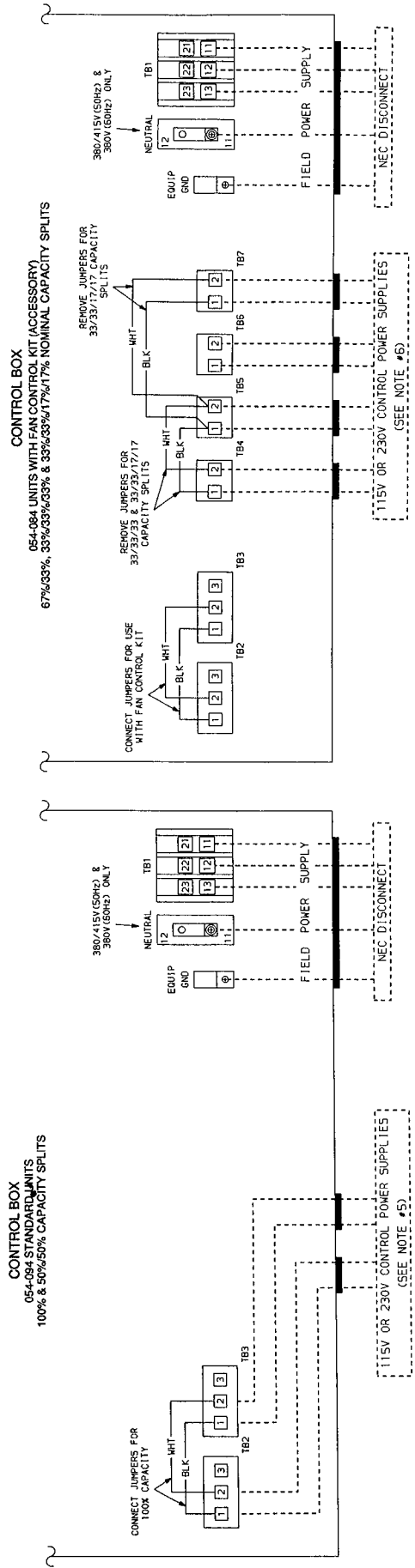
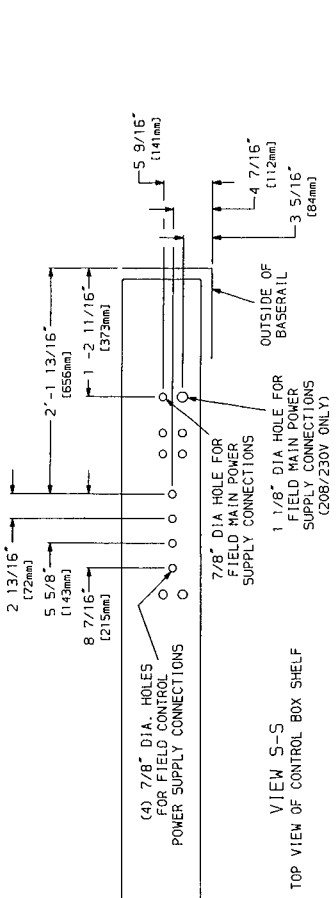

Fig. 29 — Field Wiring; 054-094 Units

MAIN POWER WIRING — The units must have adequate overcurrent protection, fuses, or HACR (Heating, Air Conditioning and Refrigeration) breakers, according to the national and applicable local codes.

For field power connections, all main power wiring enters the unit through a factory-punched access hole under the control box. Two access holes are provided; the larger should be used for 208/230 v applications. See Fig. 30. Wiring must be rated at 75 C minimum. Use copper, copper-clad aluminum, or aluminum conductors. Field power supply connections are made at terminal block 1 (TB1). Maximum incoming wire size for each terminal connection on TB1 is 2/0, and all power wiring must comply with applicable local and national codes. Refer to the unit power circuit information to determine incoming wire sizes. (See Table 4.) Refer to Table 5 for American and European wire conversion information.

CONTROL CIRCUIT POWER WIRING — Provide a separate single-phase power source for each control circuit (depending on the coil refrigerant circuit split), with the required overcurrent protection (fuses or circuit breakers). See Table 4 for control circuit overcurrent protection amperage.

For field control circuit connections, units are factory wired for a 50/50% capacity split and utilize terminal blocks 2 and 3 (TB2 and TB3). TB2 controls fans 1, 3, and 5; TB3 controls fans 2, 4, and 6. Fans 5 and 6 are on 074-094 units only. If 100% condenser application is required, connect the factory supplied jumpers from TB2-1 to TB3-1 and from TB2-2 to TB3-2, and bring incoming connections to either TB2 or TB3. Factory-punched access holes under the control box are provided for the incoming wires. See Fig. 30 for access hole details. Terminal block connections utilize no. 8 screws. Wiring must be class 1, 14 AWG (American Wire Gauge) copper conductors only. Power required for control circuits is 100 va. See Table 4 for control circuit voltage data.

GENERAL WIRING NOTES

1. Power entry is at one end only.
2. Fan motors are thermally protected. Three-phase motors are protected against primary single-phasing conditions.
3. Replacement of factory wires must be with appliance wiring material rated 105 C, or its equivalent.
4. Factory wiring is in accordance with NEC. Field modifications or additions must be in compliance with all applicable codes.

DESCRIPTION OF CONTROLS — The condenser units use a dual-voltage control scheme: A 3-phase power circuit for the fan system operation and a single-phase control circuit voltage for fan cycling control. The number of control circuit voltages depend on the coil split application used. See the head pressure control description in the service section for a detailed description of the control's function.

Table 5 — American/European Wire Conversions

AMERICAN		EUROPEAN
Industry Standard Size	American Conversion (mm ²)	Industry Standard Size (mm ²)
18 AWG	0.82	1.0
16 AWG	1.30	1.5
14 AWG	2.08	2.5
12 AWG	3.30	4.0
10 AWG	5.25	6.0
8 AWG	6.36	10.0
6 AWG	13.29	16.0
4 AWG	21.14	25.0
3 AWG	26.65	—
2 AWG	33.61	35.0
1 AWG	42.39	50.0
1/0 AWG	53.49	—
2/0 AWG	67.42	70.0
3/0 AWG	85.00	95.0
4/0 AWG	107.19	120.0
250 kcmil	126.64	150.0
300 kcmil	151.97	—
350 kcmil	177.90	185.0
400 kcmil	202.63	240.0
500 kcmil	253.29	300.0
600 kcmil	303.95	—

LEGEND

AWG — American Wire Gauge
kcmil — Thousand Circular Mills

Step 5 — Add Accessories As Needed — The following accessories are available for the 09DK054-094 condensers: Fan sound reduction kit, condenser coil coastal filter, security grille package, condenser coil hail guard package, accessory control transformer, Motormaster® III device, Motormaster III Relay/Sensor Kit, and accessory fan-control kit. Winter Start and any special electrical interlock must be considered separately. Refer to installation instructions furnished with each accessory for more information.

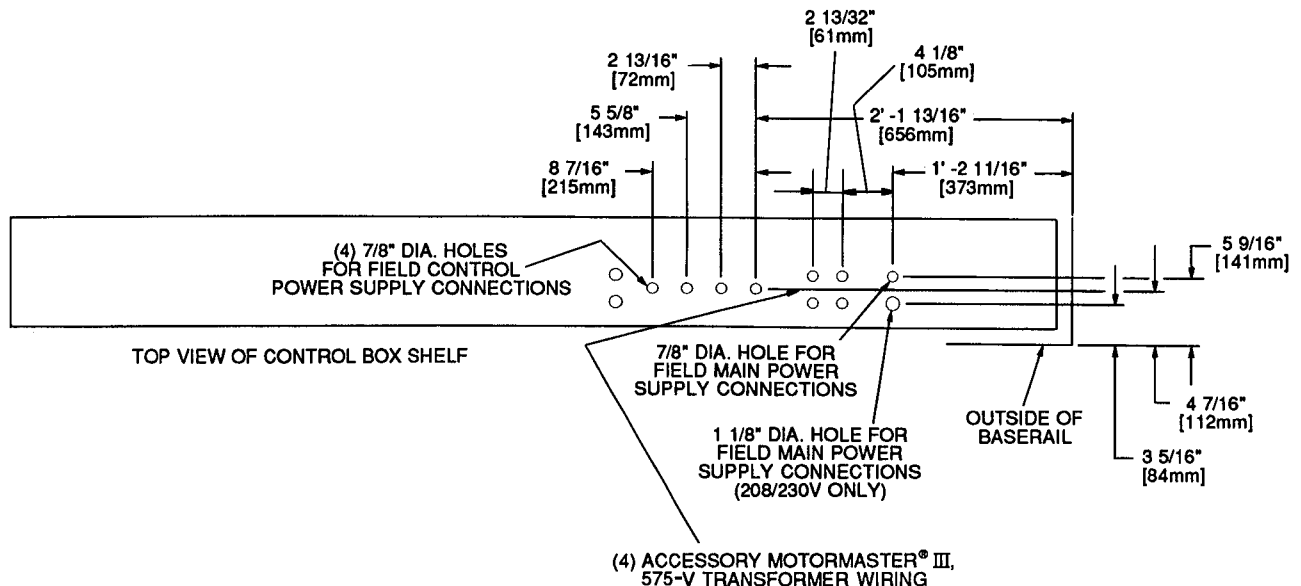

Fig. 30 — Power Wiring Access Holes; 054-094 Units

START-UP

System Evacuation and Dehydration — Refer to GTAC II, Module 4, “Dehydration for Proper Evacuation and Dehydration techniques.”

Charging Procedure — BEFORE CHARGING THE SYSTEM, INSTALL OR REPLACE THE FILTER-DRIER(S) CONNECTED TO THE LIQUID LINE WITHIN THE INDOOR UNIT(S) TO PREVENT CONTAMINATION WITHIN THE SYSTEM. Charge to a clear sight glass. Refer to GTAC II, Module 5 “Charging, Recovery, Recycling, and Reclamation” for proper charging techniques. Add 10 lbs (4.5 kg) of R-22 over clear sight glass to flood subcooler sections of the condenser coils. This 10 lbs (4.5 kg) is added to the total unit charge, and must be proportioned by the percentage of circuits when multiple circuits are employed. For example, in Table 2, add .67 x 10 lbs (4.5 kg) (approximately 6.7 lbs [3.0 kg]) for the 67% circuit. Refer to Table 6 for condenser coil refrigerant circuit data.

Check Operation of Condenser Fan Motor Controls and Rotation of Fans — *Rotation should be clockwise as viewed from top of unit.*

⚠ CAUTION

To prevent personal injury, be sure wire fan guards are secured in place over each fan before starting the unit.

IMPORTANT. Check for proper fan rotation (clockwise viewed from above). If rotation needs to be reversed on one motor, disconnect main power supply and switch motor leads at the fan contactor. If rotation needs to be reversed on all motors, disconnect main power supply and switch two leads at TB1.

SERVICE

Cleaning Condenser Coils — Clean coils with a vacuum cleaner, fresh water, compressed air, or a bristle brush (not wire). Units installed in corrosive environments should be cleaned as part of a planned maintenance schedule. In this type of application, all accumulations of dirt should be cleaned off the coil.

⚠ CAUTION

Do not use high-pressure water or air. Damage to fins may result.

Condenser Fans — Each fan is supported by a formed wire mount bolted to the fan deck and covered with a wire guard. The exposed end of the fan motor shaft is protected by grease. If the fan motor must be removed for service or replacement, be sure to grease fan shaft and reinstall fan guard. For proper performance, fan should be 7/8 in. (22 mm) below the top of the venturi on the fan deck for 60 Hz units, or 1/2 in. (13 mm) to top of the fan hub for 50 Hz units. Tighten set screws to 15 ± 1 ft-lbs (20 ± 1.3 N-m). Figure 31 shows the proper position of the mounted fan.

After servicing condenser fan motors, recheck their rotation. See the preceding Start-Up section.

Lubrication — Fan motors have permanently lubricated bearings.

Head Pressure Control — Reduces condensing capacity under low ambient temperature conditions. See Fan Cycling section below.

FAN CYCLING — The capacity of an air-cooled condenser increases with increased temperature difference (defined as entering saturated condenser temperature minus entering outdoor-air temperature) and decreases with decreased temperature difference. A drop in entering outdoor-air temperature results in a lower saturated condensing temperature. When outdoor-air temperature drops below the minimum temperatures listed in Table 7 for standard units, additional head pressure control is required.

Model 09DK units have fully automatic intermediate-season head pressure control through condenser fan cycling using electromechanical fan cycling controls. Standard head pressure controls regulate the 100 and 50/50% condenser capacity applications. Head pressure can also be controlled by fan cycling controls supplemented by the accessory Motor-master® III solid-state head pressure control. See Motor-master III installation instructions for more information. Other circuit split applications (67/33, 33/33/33, 33/33/17/17% capacity splits) require the accessory fan control kit which includes a control panel and additional fan cycling pressure switches. See fan control installation instructions for more information.

In the standard control scheme, fans 1 and 2 are on when there is a call for cooling from the respective coil circuits. Fans 1 and 2 are non-cycling. On 054 and 064 units, fans 3 and 4 are controlled by using a fan cycling pressure switch on each of the primary coil circuits in response to condensing pressure. On 074-094 units, fans 3 and 4 are controlled using a fan cycling pressure switch in each of the primary coil circuits in response to condensing pressure. Fans 5 and 6 are controlled by using two air temperature switches, which respond to the outdoor ambient temperature. The air temperature switches are located on the control box shelf. For temperature and pressure setting details, see Table 8.

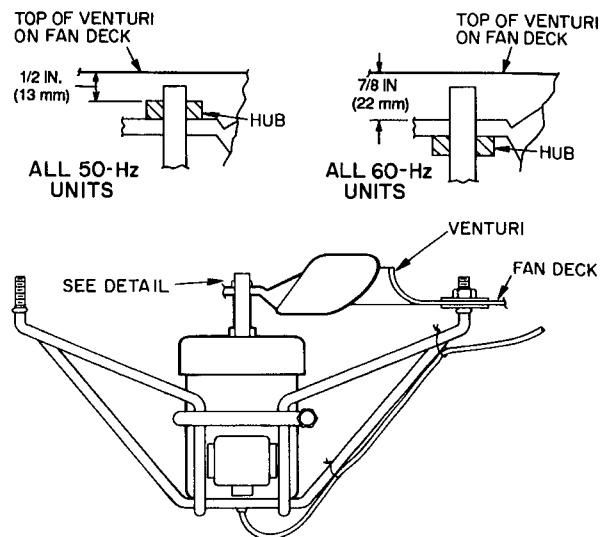

NOTE: Fan rotation is clockwise as viewed from top of unit

Fig. 31 — Condenser Fan Adjustment

The fan cycling pressure switch controls the fans as follows: Fans 3 and 4 are on above 260 ± 15 psig (1793 ± 103 kPa) and off below 160 ± 10 psig (1103 ± 69 kPa). If pressure is rising between 160 psig (1103 kPa) and 260 psig (1793 kPa), fans 3 and 4 are off. If pressure is falling from 260 psig (1793 kPa) to 160 psig (1103 kPa) fans 3 and 4 are on.

The air temperature switch controls the fans as follows: On the 074-094 condensers, below 70 ± 3 F (21.1 ± 1.7 C)

outdoor ambient, fans 5 and 6 are off; above 80 ± 3 F (26.7 ± 1.7 C) fans 5 and 6 are on. Between 70 F (21.1 C) and 80 F (26.7 C), whether fans 5 and 6 are on or off depends on whether temperature is rising or falling. If the temperature is rising from 70 F (21.1 C) to 80 F (26.7 C), fans 5 and 6 are off. If the temperature is falling from 80 F (26.7 C) to 70 F (21.1 C), fans 5 and 6 are on.

Table 6 – Condenser Coil Refrigerant Circuit Data

UNIT		09DK054				09DK064			
COIL									
No. of Ckts		2	1	2	2	2	1	2	2
Cap. (% Ckt)		50	66	34	16	50	66	34	16
REFRIGERANT									
Min Chg/Ckt	kg	11.0	14.5	7.5	3.6	16.5	21.7	11.3	5.2
	lb	24.2	31.8	16.5	7.6	36.3	47.7	24.8	11.5
Oper Chg/Ckt	kg	12.9	17.0	8.8	4.1	19.4	25.5	13.3	6.1
	lb	28.4	37.4	19.5	9.0	42.7	56.2	29.2	13.5
Vol/Ckt	m ³	0.019	0.025	0.013	0.006	0.029	0.037	0.02	0.009
	cu ft	0.68	0.89	0.46	0.21	1.01	1.32	0.69	0.32
STORAGE CAPACITY									
R-12	kg	19.7	25.9	13.5	6.2	29.2	38.4	20.0	9.2
	lb	43.3	57.0	29.6	13.7	64.3	84.6	43.0	20.3
R-22	kg	18.0	23.7	12.3	5.7	26.8	35.2	18.3	8.5
	lb	39.6	52.2	27.1	12.5	58.9	77.6	40.3	18.6
R-500	kg	17.0	22.3	11.6	5.4	25.1	33.0	17.2	7.9
	lb	37.4	49.2	25.6	11.8	55.2	72.7	37.8	17.5
R-502	kg	18.8	24.8	12.9	6.0	27.9	36.7	19.1	8.8
	lb	41.5	54.6	28.4	13.1	61.4	80.8	42.0	19.4
R-134A	kg	19.7	25.9	13.5	6.2	29.2	38.4	20.0	9.2
	lb	43.3	57.0	29.6	13.7	64.3	84.6	44.0	20.3

UNIT		09DK074				09DK084				09DK094
COIL										
No. of Ckts		2	1	2	2	2	1	2	2	2
Cap. (% Ckt)		50	68	32	18	50	67	33	17	50
REFRIGERANT										
Min Chg/Ckt	kg	15.9	21.6	10.2	5.7	23.9	31.8	15.9	8.0	26.2
	lb	35.0	47.6	22.5	12.5	52.2	70.1	35.0	17.6	57.8
Oper Chg/Ckt	kg	18.7	25.4	12.0	6.7	28.1	37.5	18.7	9.4	30.8
	lb	41.2	56.0	26.5	14.8	61.8	82.5	41.2	20.7	68.0
Vol/Ckt	m ³	0.028	0.037	0.018	0.010	0.041	0.055	0.028	0.014	0.046
	cu ft	0.97	1.32	0.62	0.35	1.46	1.95	0.97	0.49	1.64
STORAGE CAPACITY										
R-12	kg	28.5	38.7	18.3	10.2	43.3	57.6	28.8	14.4	47.5
	lb	62.8	85.3	40.3	22.5	95.3	127.0	63.5	31.8	104.7
R-22	kg	26.1	35.4	16.8	9.3	39.5	52.7	26.3	13.2	43.4
	lb	57.5	78.0	36.9	20.6	87.0	116.0	58.0	29.0	95.7
R-500	kg	24.6	33.4	15.8	8.8	37.2	49.7	24.8	12.4	40.8
	lb	54.2	73.6	34.8	19.4	82.0	109.3	54.7	27.3	90.0
R-502	kg	27.3	37.1	17.5	9.8	41.3	55.1	27.6	13.8	45.4
	lb	60.4	81.7	38.6	21.5	91.0	121.3	60.7	30.3	100.1
R-134A	kg	28.5	38.7	18.3	10.2	43.3	57.7	28.8	14.4	47.5
	lb	62.8	85.3	40.3	22.5	95.3	127.0	63.5	31.8	104.7

NOTE: Storage capacity calculated for 80% liquid and 20% vapor at 90 F (32.2 C)

Table 7 – Minimum Outdoor-Air Operating Temperature

English

UNIT 09DK	HEAD PRESSURE CONTROL	TD ° F	COMPRESSOR CAPACITY (%)*			
			100	75	50	25
			Minimum Outdoor-Air Temperature ° F			
All Sizes	FCPSs and Motormaster® III	30 25 20	-20	-20	-20	-20
054, 064	FCPSs† 2 Fans	30	29	34	38	51
		25	38	40	42	53
		20	47	47	46	56
074-094	FCPSs† 2 Fans ATSs 2 Fans	30	12	19	22	43
		25	22	25	29	47
		20	31	31	36	51

SI

UNIT 09DK	HEAD PRESSURE CONTROL	TD ° C	COMPRESSOR CAPACITY (%)*			
			100	75	50	25
			Minimum Outdoor-Air Temperature ° C			
All Sizes	FCPSs and Motormaster III	16.7 13.9 11.1	-29	-29	-29	-29
054, 064	FCPSs† 2 Fans	16.7	-2	1	3	11
		13.9	3	4	6	12
		11.1	8	8	8	13
074-094	FCPSs† 2 Fans ATSs 2 Fans	16.7	-11	-7	-6	6
		13.9	-6	-4	-2	8
		11.1	-1	-1	2	11

LEGEND

ATS – Air Temperature Switch
FCPS – Fan Cycling Pressure Switch
TD – Temperature Difference = Saturated Condensing
 Temperature Entering – Entering-Air Temperature

*Interpolation permitted; compressor capacity per condenser circuit.
 †Additional FCPSs needed for 67/33, 33/33/33, and 33/33/17/17%
 capacity split applications

NOTES:

1. Fans on the 09DK054-094 units are controlled by ATSs and FCPSs. See Table 8 for more details.
2. Minimum outdoor temperatures are determined for indoor and outdoor unit combinations of the same capacity.

Table 8 – Fan Cycling Controls Temperature/ Pressure Settings

English

UNIT 09DK	FCPS OPENS AT 160 ± 10 psig CLOSES AT 260 ± 15 psig	ATS OPENS AT 70 ± 3° F CLOSES AT 80 ± 3° F
054,064	FM 3,4*	---
074-094	FM 3,4*	FM 5,6†

SI

UNIT 09DK	FCPS OPENS AT 1103 ± 69 kPa CLOSES AT 1793 ± 103 kPa	ATS OPENS AT 21.1 ± 1.7° C CLOSES AT 26.7 ± 1.7° C
054,064	FM 3,4*	---
074-094	FM 3,4*	FM 5,6†

LEGEND

ATS – Air Temperature Switch
FCPS – Fan Cycle Pressure Switch
FM – Fan Motor

*Fan motors 3 and 4 are each controlled by a FCPS for 100 and 50/50% capacity split applications. For other capacity split options, the accessory fan control kit must be used and additional FCPSs are required. See accessory fan control kit installation instructions for more information.

†Fan motors 5 and 6 are each controlled by an ATS.

PACKAGED SERVICE TRAINING

Our packaged service training programs provide an excellent way to increase your knowledge of the equipment discussed in this manual. Product programs cover:

- Unit Familiarization
- Maintenance
- Installation Overview
- Operating Sequence

A large selection of product, theory, and skills programs is available. All programs include a video cassette and/or slides and a companion booklet. Use these for self teaching or to conduct full training sessions.

For a free Service Training Material Catalog (STM), call 1-800-962-9212. Ordering instructions are included.

Free Manuals Download Website

<http://myh66.com>

<http://usermanuals.us>

<http://www.somanuals.com>

<http://www.4manuals.cc>

<http://www.manual-lib.com>

<http://www.404manual.com>

<http://www.luxmanual.com>

<http://aubethermostatmanual.com>

Golf course search by state

<http://golfingnear.com>

Email search by domain

<http://emailbydomain.com>

Auto manuals search

<http://auto.somanuals.com>

TV manuals search

<http://tv.somanuals.com>