

Heat Pump - Outdoor Section

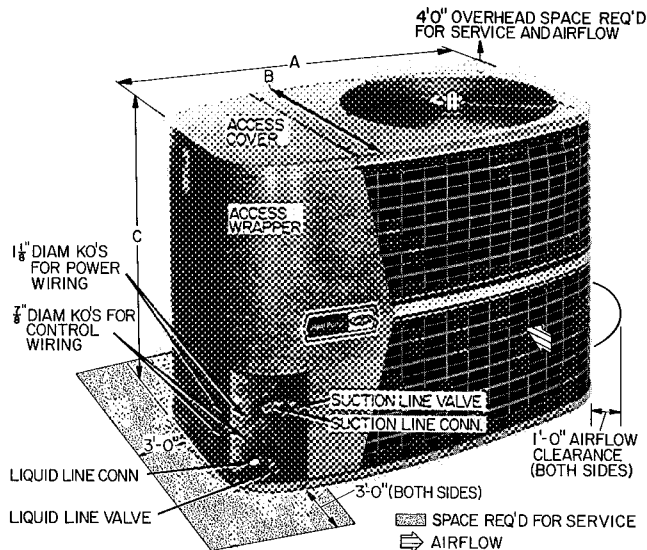

Certified dimension drawings are available on request

Fig. 1 — Dimensions and Connections (Table 1)

Table 1 — Installation Data (Fig. 1)

UNIT 38CQ	015	020	027	033	039	044	048	
OPER WT (lb)	145	160	166	180	210	212	220	
UNIT DIM. (ft.-in.)								
Length	A		2-10 $\frac{1}{4}$					
Width	B		1-10					
Height	C		1-4 $\frac{1}{8}$	1-4 $\frac{1}{8}$	1-4 $\frac{1}{8}$	2-0 $\frac{3}{8}$	2-0 $\frac{3}{8}$	2-6 $\frac{1}{8}$
REFRIG CONN (in.)	Compatible Fitting (Suct) & Flare (Liq)							
Suction* (ODF)	$\frac{5}{8}$		$\frac{5}{8}$	$\frac{3}{4}$	$\frac{7}{8}$	$1\frac{1}{8}$	$1\frac{1}{8}$	
Liquid* (ODF)	$\frac{5}{8}$		$\frac{3}{8}$					

*Recommended field supplied refrigerant line sizes

UNIT 38CQ	015	020	027	033	039	044†	048†
SUCTION (in. ODF)	$\frac{5}{8}$	$\frac{5}{8}$	$\frac{3}{4}$	$\frac{3}{4}$	$\frac{7}{8}$	$1\frac{1}{8}$	$1\frac{1}{8}$
LIQUID (in. ODF)	$\frac{3}{8}$						

†May use 7/8-in. accy tubing package (slight capacity loss) See p 3 NOTES:

- Maximum length of interconnecting tubing is 50 feet
- Units 38CQ044, 048 factory supplied with 3/4 to 1-1/8 in suction valve adapter (field installed) for field-supplied 1-1/8 in suction line

INSTALLER'S PRELIMINARY SURVEY

Step 1 — Unpackage Unit — Move heat pump to final location. Open carton at end marked "compressor end." Slide unit from carton taking special care to not damage service valves or grilles.

Step 2 — Inspect Equipment — File claim with shipping company if shipment is damaged or incomplete.

Step 3 — Complete or Consider the Following before installing the 38CQ unit.

Consult local building codes and National Electrical Code (NEC) for special installation requirements.

When installing unit, allow sufficient space for airflow clearance, wiring, refrigerant piping and servicing unit. Position unit so water or ice from roof will not drop directly on top of unit.

Make provisions for condensate drainage and defrost water disposal whether unit is installed on ground or roof. (Make sure unit base pan drainage holes are not blocked.) See Mounting Pad for details. Roof installation method for 38CQ depends on building construction and special requirements of local codes. Roof must be capable of supporting unit weight. Maximum allowable vertical distance between indoor and outdoor sections is 50 feet. See Table 2.

Use an indoor coil with a bleed-type expansion device. (See Table 2 for Carrier approved indoor sections.) If coil does not have a bleed-type expansion device, it may be necessary to add an accessory start capacitor and relay to heat pump. This would require removing compressor start thermistor (PTC device) on units so equipped. *It is recommended that 38CQ units be used with Carrier approved indoor sections, all of which are equipped with a bypass type AccuRater™ (bleed-type expansion device).*

Table 2 — Carrier Approved 38CQ System Data

OUT-DOOR UNIT	REFRIG-ERANT	INDOOR UNIT			HEIGHT (ft)	
		Fan	Coil	Accu-Rater Piston No.	Indoor Unit Above	Below Outdoor Unit
→ 38CQ015	22		40AQ018	11		
38CQ020			40AQ024	2		
38CQ027			40AQ024*	4*		
			40AQ030	4		
38CQ033			40AQ030*	6*		
			40AQ036	6		
38CQ039			40FS160 28MQ036	6	50	50
			40AQ036*	7*		
			40FS160 28MQ036*	7*		
38CQ044			40FS160 28MQ042	7		
			40FS160 28MQ042*	7*		
38CQ048			40FS200 28MQ048	7		
			40FS200 28MQ048*	8*		

*Indoor units that require replacement of AccuRater refrigerant control piston for optimum performance when used with specified outdoor unit. The 38CQ048 is factory supplied with no. 8 piston for indoor unit (28MQ048)

MOUNTING PAD

Step 4 – On the Ground: Mount Unit on a Solid, Level Concrete Pad. See Fig. 2 for pad dimensions. Position unit so that coil drainage holes in base pan overhang the pad. Make sure pad does not obstruct drainage holes (holes drain water during heating and defrost cycles). Unit can be attached to pad with mastic adhesive or by drilling holes in base pan for 1/4-in. mounting bolts.

Construct pad a minimum of 6-in. thick to provide clearance under holes for drainage and ice buildup. In areas where prolonged subfreezing temperature or heavy snows occur: increase clearance to 12 to 18 in. by constructing an angle iron frame to support unit 12 to 18 in. off concrete base. Cross angle of frame must not obstruct coil drainage holes. See Fig. 3 for recommended frame construction. Extend a 12-in. gravel apron around pad for condensate and defrost water drainage field.

Step 5 – On the Roof: Mount Unit on a Level Platform or Frame: Unit must be elevated for

proper clearance as described under ground installation above. Roof design and water drainage must be planned to prevent unit from setting in water. Flash all roof openings to prevent leaks.

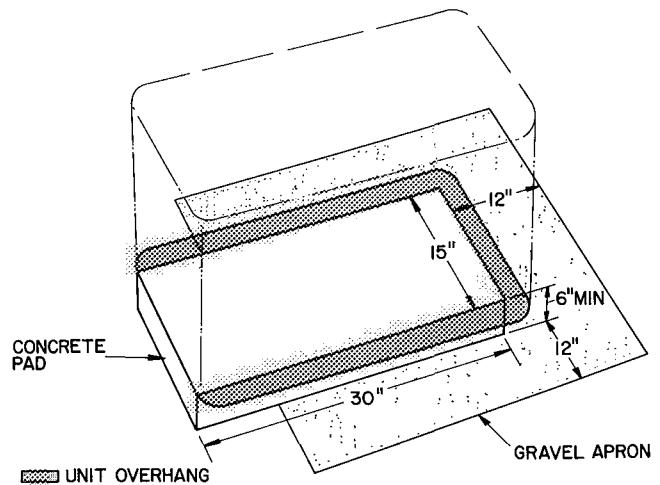

Fig. 2 – Concrete Pad Dimensions

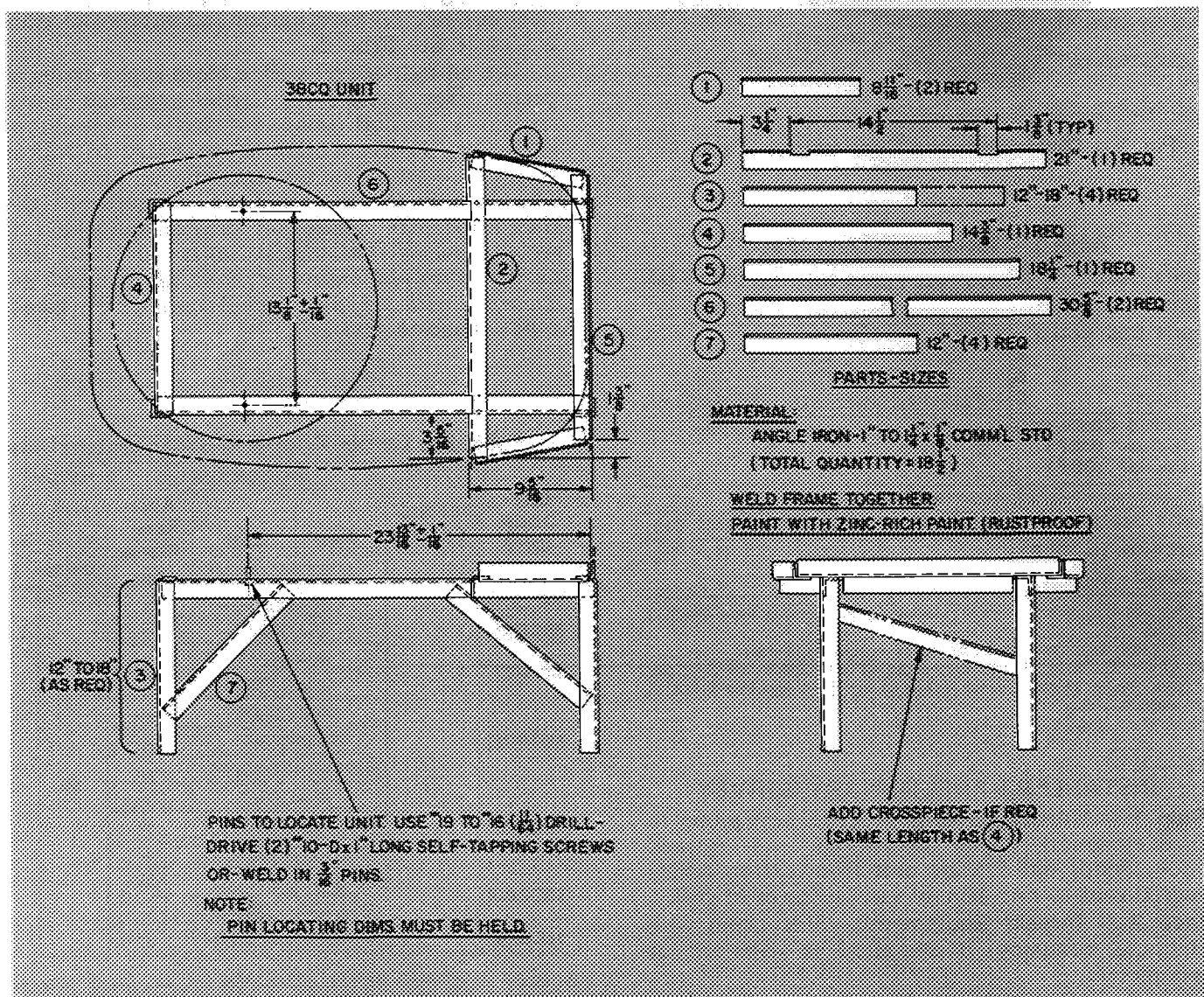

Fig. 3 – Heat Pump Mounting Frame

Table 3 – Accessories

PART NO.	DESCRIPTION						
38CQ900081	Low-Voltage Control – Honeywell Thermostat HH07AT071 and Thermostat Subbase HH93AZ073 – (Automatic Changeover)						
38CQ900111	Low-Voltage Control – Honeywell Thermostat HH07AT071 and Thermostat Subbase HH93AZ075 – (Manual Changeover)						
38CQ900182	Service Sentry (Six HN65CT002)						
38GS900381	Start Capacitor and Relay Package						
38CQ900061	Flare (3/8-in.) to Compatible (3/8-in.) Couplings (Two-Pack)						
38CQ900091	Liquid Line Filter-Drier						
→ 38RQ900001	Emergency Heat Relay (Required with 2 outdoor thermostats.) (Service Parts)						
→ 38RQ900021	Outdoor Thermostat (Six 38RQ900032)						
HH22AG110	Optimizer Control						
38CQ900141	Solid State Time Guard (24 volt)						
TUBING							
TUBING PACKAGE	Length (ft)	Liquid		Suction*			UNIT
		OD (in.)	Tube End OD (in.)	OD (in.)	Tube End OD (in.)		
					Evap	Cond	
38GC900031	10	3/8	3/8	5/8	3/4 †	5/8	38CQ015,020
38GC900041	18	3/8	3/8	5/8	3/4 †	5/8	
38GS900221	25	3/8	3/8	5/8	3/4 †	5/8	
38GC900061	35	5/16	3/8	5/8	3/4 †	5/8	
38GC900191	50	1/4	3/8	5/8	3/4 †	5/8	
38GC900071	10	3/8	3/8	3/4	3/4	3/4	38CQ027,033
38GC900081	18	3/8	3/8	3/4	3/4	3/4	
38GC900091	25	3/8	3/8	3/4	3/4	3/4	
38GC900101	35	3/8	3/8	3/4	3/4	3/4	
38GC900111	50	3/8	3/8	3/4	3/4	3/4	
38CQ900001	18	3/8	3/8	7/8 ‡	3/4	3/4	38CQ039,044,048
38CQ900011	25	3/8	3/8	7/8 ‡	3/4	3/4	
38CQ900021	35	3/8	3/8	7/8 ‡	3/4	3/4	
38CQ900031	50	3/8	3/8	7/8 ‡	3/4	3/4	

*Suction line is insulated and has a 90° bend at one end
 †For 5/8-in. evaporator connection, cut off 3/4-in. end

‡Capacity reduction may occur when 7/8-in. accessory tubing is used on 38CQ044,048

PIPING CONNECTIONS

The 38CQ units can be connected to indoor units using Carrier accessory tubing package or field-supplied tubing of refrigerant grade. See Table 1 (with notes) for unit piping connection type, size and line size recommendations and Table 3 for accessory tubing sizes. *Maximum length of refrigerant piping allowed is 50 feet*

A capacity reduction will result if accessory tubing is used in 38CQ044,048 systems. For example, when a 25-ft, 7/8-in. accessory tubing package is used, there will be a capacity reduction of 1-1/2%. For maximum capacity, use 1-1/8 in. suction line as recommended in Table 1.

When other than 25 ft of interconnecting piping is used, follow special requirements described in Refrigerant Charging. Do not use less than 10 ft of accessory liquid line. Do not cut 5/16-in. or 1/4-in. liquid line. Do not cut 7/8-in. suction line. Bend or coil to fit.

Do not use damaged or contaminated tubing. Always evacuate or purge evaporator coil and tubing system (use field-supplied refrigerant, not unit refrigerant).

When making tubing connections, be sure to provide clearance at unit for electrical connections.

→ To assure noise-free installation, isolate refrigerant lines from ductwork and framing or where they run thru stud spaces, enclosed ceilings or pipe chases. Use isolation hangers (Fig. 4), as rigid fastening may transmit pulsations to structure, creating an objectionable rumble. Do not attach liquid line to uninsulated suction line. When running thru structure, surround all lines with 1-in. insulation to prevent transmission of vibration.

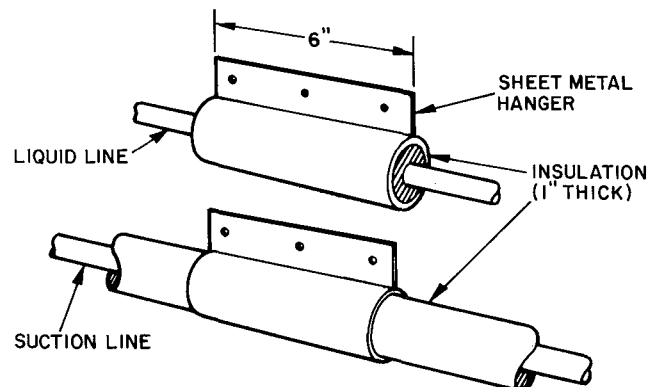

Fig. 4 – Refrigerant Line Hangers
 Before Connecting Refrigerant Lines, replace the AccuRater™ refrigerant control piston in the indoor coil as required. See Table 2. The 38CQ048 is

factory supplied with a No. 8 AccuRater piston for installation in 28MQ048. For piston replacement instructions, see AccuRater™ Servicing on page 15.

Step 6 – Connect Refrigerant Lines to fittings on unit suction and liquid service valves (Fig. 1). *Liquid service valve has flare fitting; suction service valve has Compatible Fitting.* Make suction line connection first. Slide flare nut on liquid line, then flare and connect liquid line. (Do not disassemble AccuRater.) Unit Compatible Fitting permits mechanical (quick-connect) or sweat connection as described below. It is not necessary to flare system liquid line if an accessory flare to Compatible Fitting coupler is used for liquid line connection. See Accessory Coupler (Fig. 5).

38CQ044,048 UNITS – When using 1-1/8 in. field-supplied suction line, remove suction line adapter taped to compressor suction line. Sweat connect refrigerant suction line to 1-1/8 in. end of adapter. Connect 3/4-in. end of adapter to unit suction line Compatible Fitting.

When a 7/8-in. field-supplied suction line is used on 38CQ039, a field-supplied 3/4-in. to 7/8-in. suction line adapter must be provided (not required if 38CQ accessory tubing is used).

MECHANICAL CONNECTION TO COMPATIBLE FITTING (Mate one set of connections at a time.)

1. Loosen nut on Compatible Fitting one turn. Do not remove.
2. Remove plug and be sure O-ring is in the groove inside the Compatible Fitting.
3. Cut tubing to correct length.
4. Insert tube into Compatible Fitting until it bottoms.
5. Tighten nut until it bottoms on back coupler flange. Keep tube bottomed in Compatible Fitting while tightening nut.

SWEAT CONNECTION TO COMPATIBLE FITTING (Use refrigerant tubing.)

1. Remove locking nut, rubber O-ring and Schrader core from valve.
2. Cut tubing to correct length.
3. Insert tube in Compatible Fitting. Wrap top and bottom of service valves in wet cloth to prevent damage by heat. Solder with low temperature (450 F) silver alloy solder.
4. Replace Schrader core.
5. Evacuate or purge system with field-supplied refrigerant.

ACCESSORY FLARE TO COMPATIBLE COUPLER is shown in Fig. 5. Attach flare nut on coupler to flare fitting on unit liquid service valve. Connect liquid line to Compatible Fitting using mechanical or sweat connection. When mechanical connection is made, use 2 wrenches when tightening Compatible Fitting nut – one to hold coupler and one to tighten nut. Liquid line must be flared if coupler is not used.

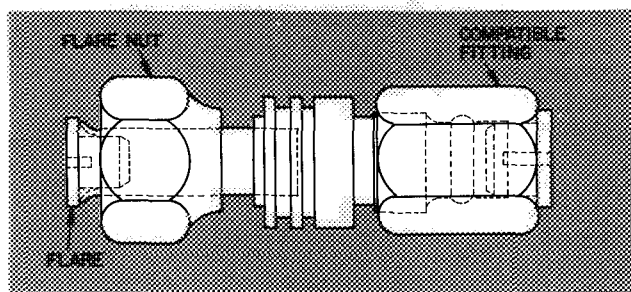

Fig. 5 – Accessory Coupler

ELECTRICAL DATA AND WIRING

Field wiring must comply with local and national fire, safety and electrical codes. Voltage to unit must be within $\pm 10\%$ of voltage indicated on

Table 4 – Electrical Data (60-Hz)

UNIT	V/PH	OPER VOLTAGE*		COMPR		FAN FLA	BRANCH CIRCUIT			
		Max	Min	LRA	RLA		Power Wire Size (AWG)	Max Ft Wire	Gnd Wire Size† (AWG)	Max Fuse Amps‡
38CQ015	230/1	254	207	41	9.0	.9	14	31	14	20
38CQ020				65	10.3	.9	12	40	12	20
38CQ027				82	17.7	2.4	10	42	10	40
38CQ033				88	19.8	2.4	10	36	10	45
38CQ039				94	22.2	2.4	10	33	10	50
38CQ044				106	25.0	2.4	8	46	8	50
38CQ048				106	25.0	3.0	8	46	8	50
38CQ033	200/ 230/3	254	180	87	13.0/ 11.5	2.0/ 2.0	12	40	12	30/ 25
38CQ039	200/3	229	180	79	17.4	2.4	12	31	12	40
38CQ044				87	18.6	2.4	10	35	10	40
38CQ048				87	18.6	3.0	10	35	10	40
38CQ039	230/3	254	207	67	15.0	2.4	12	41	12	35
38CQ044				70	16.7	2.4	12	36	12	35
38CQ048				70	16.7	3.0	12	36	12	35

FLA – Full Load Amps

LRA – Locked Rotor Amps

RLA – Rated Load Amps

*Permissible limits of the voltage range at which the units will operate satisfactorily

†Required when using nonmetallic conduit

‡Maximum dual element fuse size

NOTES:

1 Fan motors are 200-v or 230-v, single phase

2 All units have 24-v control circuit which requires external power source

3 Copper wire sizes based on 60 C. Use copper or copper-clad aluminum wire only. Use latest National Electrical Code for wire sizing

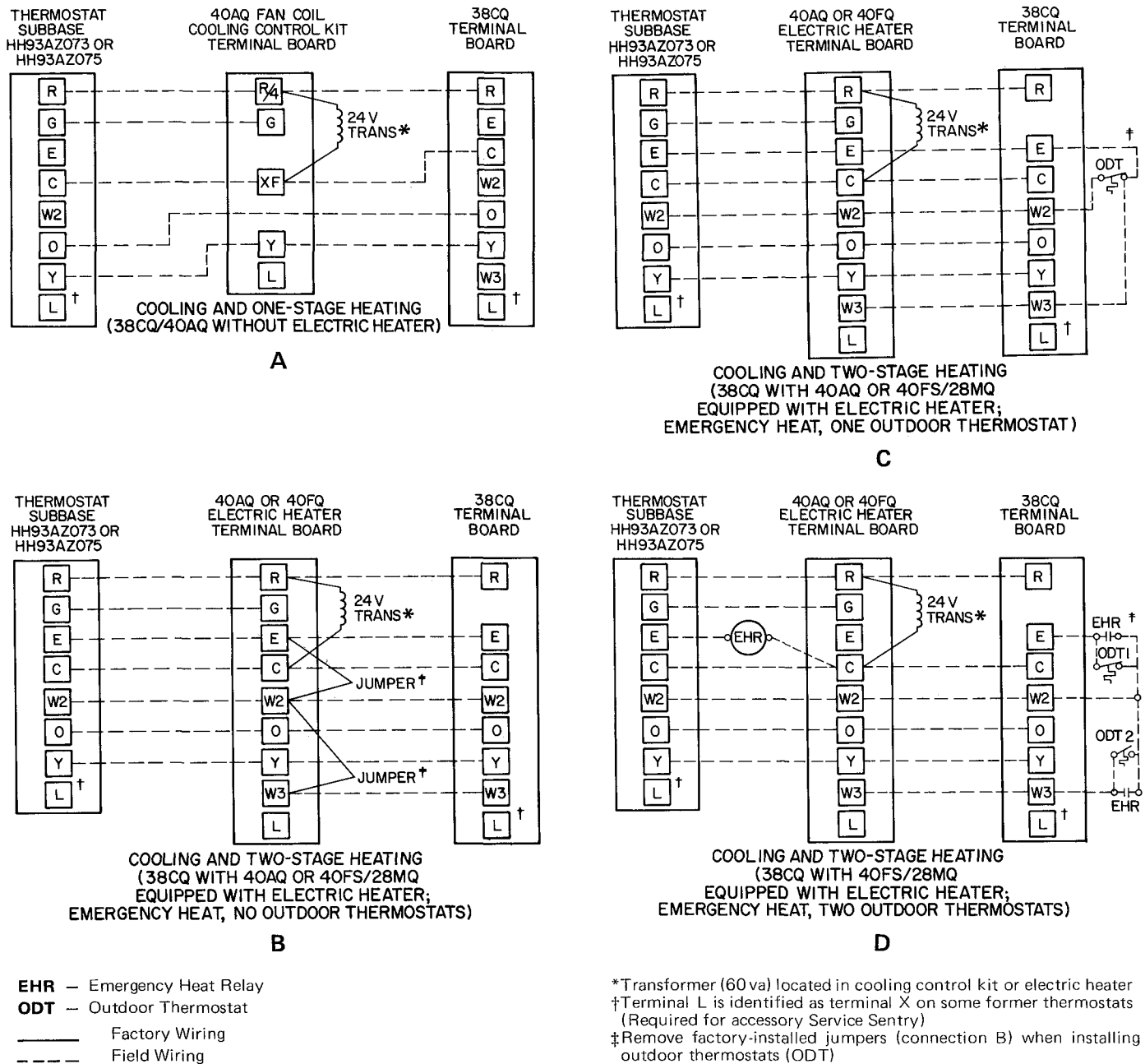

→ Fig. 6 – Control Circuit Connections

nameplate. On 3-phase units, phases must be balanced within 2%. Contact local power company for correction of improper line voltage.

Operation of unit on improper line voltage or with excessive phase unbalance constitutes abuse and is not covered by Carrier warranty.

When making electrical connections, provide clearance at unit for refrigerant piping connections. See Table 4 for recommended wire and fuse sizes.

Step 7 – Install a Branch Circuit Fused Disconnect of adequate size to handle unit starting current. Provide a separate fused disconnect for outdoor unit, indoor unit and for each accessory electric heater circuit as required. (See Indoor Unit and Electric Heater Installation, Start-Up and Service Instructions.) Locate disconnect(s) within sight of and readily accessible from the unit, per section 440-14 of National Electrical Code (NEC).

Step 8 – Bring Line Power Leads Into Unit – Extend leads from fused disconnect thru hole provided in service embossment (Fig. 1) and thru 7/8-in. hole into control box.

Step 9 – Connect Ground Lead to a Ground Lug in Control Box for safety. Connect power wiring. See Fig. 7. Splice line power leads to yellow and black pigtails on single-phase units or to black pigtails (3) on 3-phase unit. Use wire nuts supplied with unit. Tape each connection.

Step 10 – See Indoor Unit and Electric Heater Installation, Start-Up and Service Instructions for line power wiring details. All control wiring is shown in this booklet.

Step 11 – Control Power Wiring (24 v) is brought thru hole in unit service embossment, Fig. 1. Connect leads to control wiring terminal board (located on outside of control box) as shown in Fig. 6.

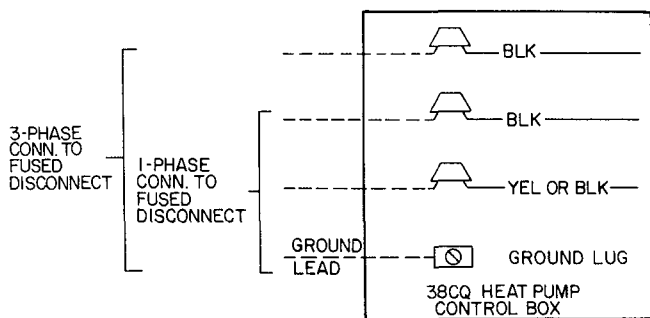

Fig. 7 – Line Power Connections

Use indoor unit transformer as 24-v supply for system. At least a 60-va transformer is recommended. Carrier approved indoor units are equipped with 60-va transformer. See indoor unit data.

Use Carrier accessory indoor thermostat HH07AT071 with HH93AZ073 or HH93AZ075 subbase.

INITIAL START-UP

The 38CQ unit is equipped with a crankcase heater. It is recommended that heater be energized a minimum of 24 hours before starting unit. To energize heater only, turn the thermostat to OFF position and close electrical disconnect to heat pump.

Heat Anticipator Settings for Room Thermostat (HH07AT071) – Set anticipator settings for room thermostat according to Table 5. These settings may be changed slightly to provide a greater degree of comfort for a particular installation.

→ **Table 5 – Thermostat Anticipator Settings**

UNIT 38CQ	FIRST- STAGE ANTICIPATOR SETTING	INDOOR UNIT WITH ELECTRIC HEATER	HTR KW	SECOND- STAGE ANTICIPATOR SETTINGS
015	Fixed	40AQ Fan-Coil with 40AQ Htrs or 40FS/28MQ with 40FQ Htrs	5 0	16
020			7 5	
027			10 0	
033			15 0	33
039			20 0	
044			25 0	
048			30 0	49
			34 0	

Accessory Outdoor Thermostat provides adjustable outdoor control of accessory electric heater. This thermostat makes contact when a drop in outdoor temperature occurs. It energizes a stage of electric heat when the outdoor temperature setting is reached, provided the room thermostat is on the second stage of heating. One outdoor thermostat is recommended for each stage of electric heat after the first stage. Set the outdoor thermostat(s) progressively lower for each stage. Refer to heat load of building and unit capacity to determine the correct outdoor thermostat settings.

The accessory emergency heat relay is required when 2 outdoor thermostats are used. It is automatically energized by the manually operated

emergency heat switch in the indoor thermostat subbase. The thermostat locks out compressor and the relay bypasses the outdoor thermostats for electric heater operation during heat pump shut-down. When one outdoor thermostat is used, an emergency heat relay is not required. The emergency heat switch in the indoor thermostat subbase bypasses outdoor thermostat, locks out compressor and activates electric heater. See 40FS Indoor Unit and Electric Heater Installation, Start-Up and Service Instructions for installation of emergency heat relay.

→ **Accessory Outdoor Thermostat(s) Installation** –

Install outdoor thermostat at a suitable location on the outside of the control box. Use any free hole to fasten thermostat bracket. *Be sure that engagement screw does not interfere with wiring or components inside of control box* Thermostat bracket may be secured with only one screw; however, make sure that bracket is firmly attached to resist vibration forces. If a free hole is not available, *drill hole in control box after assuring that drilling will not damage any components inside of box* If a second thermostat is used, follow the procedure outlined above. If there is no available space on the control box for a second thermostat, mount the 2 thermostats together. Connect the 2 thermostats with a machine screw, lock washer and nut, and then mount assembled thermostats to the control box (See Fig. 8a). Route the capillary and attached bulb below the control box to the upper portion of the outdoor coil grille. Carefully insert the bulb between the tube sheet and nearest vertical grille wire. Place the bulb across the grille and fasten with wire, wire ties or other suitable fastener (See Fig. 8b). Never expose bulb to direct sunlight. If necessary, shield bulb with appropriate material.

Replace access wrapper on unit. *Check that capillary is not pinched by wrapper*

To Start Unit – (Make sure crankcase heater has been energized for 24 hours.) Adjust the thermostat as follows:

1. Set selector switch at OFF.
2. Turn on main disconnect switch(es) to indoor and outdoor units.
3. Set fan switch as desired (ON or AUTO.).
4. Set thermostat dial at desired temperature.
5. Set selector switch at HEAT or COOL.

Check system refrigerant charge. See Refrigerant Charging.

SERVICE

Refrigerant Charging – The 38CQ units contain correct operating charge for complete system when connected to 40FS/28MQ or 40AQ indoor units with 25 ft of tubing of recommended diameter. Charge adjustment is required on other systems. Adjust system charge for refrigerant line lengths and diameters that differ from 25 ft and 3/8-in.

OD (liquid line), respectively, using refrigerant weights shown in table below. (Twenty-five feet of 3/8-in. OD tubing contains 14.4 oz of R-22.) Add R-22 charge to system if liquid line is over 25 ft; remove charge if liquid line is shorter than 25 feet.

LIQUID LINE DIAM (in.)	OUNCES OF R-22/FT LENGTH OF LIQUID LINE
3/8	58
5/16	36
1/4	21

→ Table 6 – Service Data

UNIT 38CQ	015, 020	027	033	039	044	048
R-22 CHG (lb-oz)	4-10	4-11	6-5	7-11	7-13	7-10
REFRIG CONTROL	AccuRater™ (Bypass Type)					
FAN	Propeller – Direct Drive					
Cfm	2600	2600	2800	2800	2600	3400
Rpm	1075					
Diam (in.)	17	17	18	18	16	18
Motor Hp	1/8	1/4	1/4	1/4	1/4	1/2

When recharging is necessary during heating or cooling season, weigh in total charge indicated in Table 6. (Charge must be weighed in during heating season.) Remove any refrigerant remaining in

system before recharging. If system has lost complete charge, evacuate system to 500 microns (29.7 in. vacuum) before recharging. Service port connections are provided on liquid and suction line service valves for evacuation and charging. (See Fig. 32 for correct service port location on cooling and heating cycles.) Dial-a-charge charging cylinder is an accurate device used to recharge systems by weight. These cylinders are available at refrigeration supply firms.

To check and/or adjust charge during cooling season, use correct Cooling Cycle Charging Chart → (Fig. 9, 11, 13, 15, 17, 19, 21, 23, 25, 27, 29) and follow Charging Chart Method below. The charging chart may also be used as an alternate method of recharging system.

To check *system operation* during heating cycle, use correct Heating Cycle Operation Check → Chart (Fig. 10, 12, 14, 16, 18, 20, 22, 24, 26, 28, 30). These charts indicate whether a correct relationship exists between system operating pressures and air temperatures entering indoor and outdoor units. If pressure and temperature lines do not intersect on chart, the system refrigerant charge may not be correct or other system abnormalities may exist. Do not use Operation Check Charts to adjust refrigerant charge. Weigh charge into system.

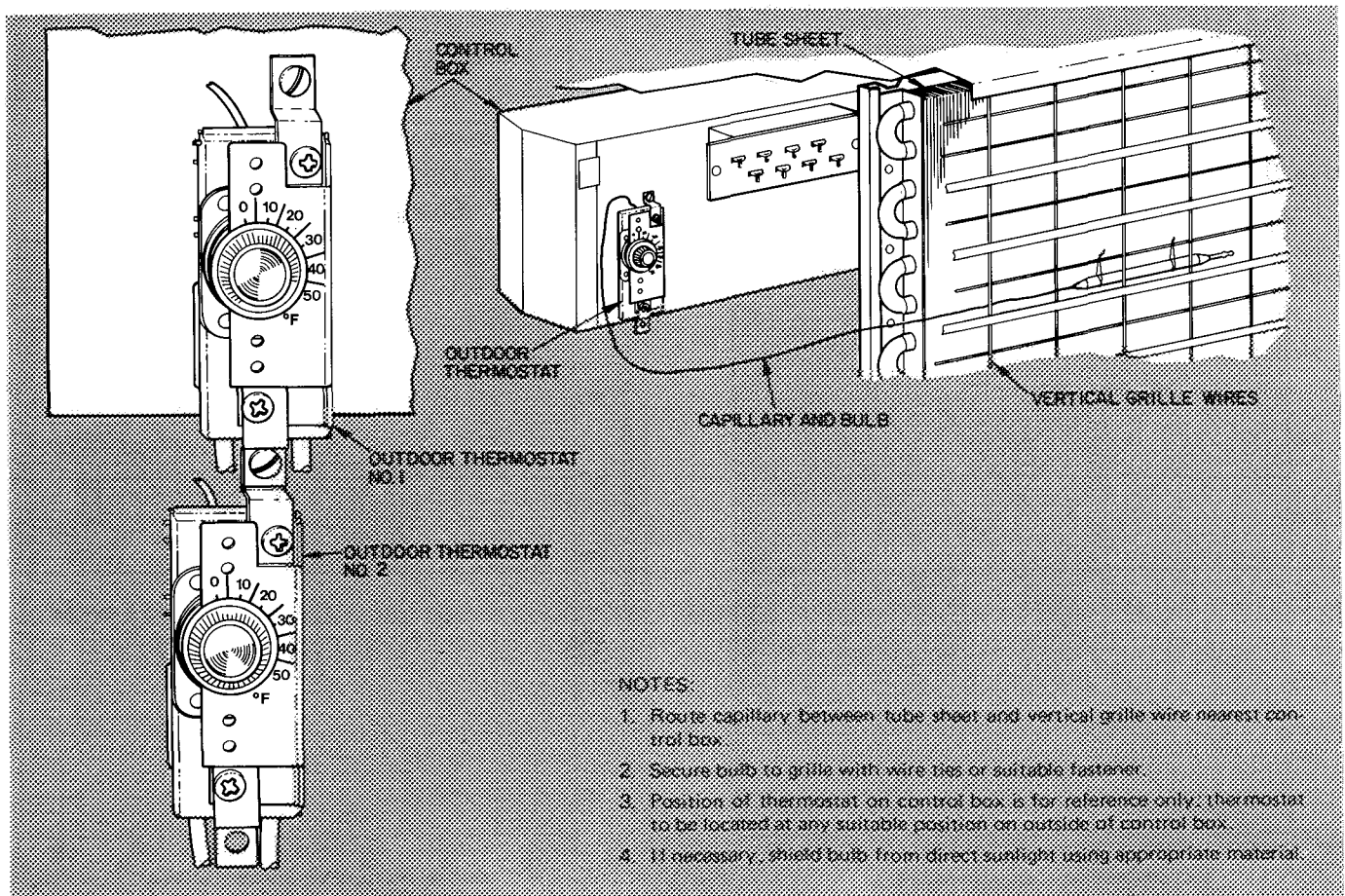

a. 2 – Thermostat Assembly

b. Capillary Tube Routing

→ Fig. 8 – Outdoor Thermostat Installation Details

COOLING CYCLE CHARGING CHART METHOD

1. Operate unit a minimum of 10 minutes before checking charge, and after each charge adjustment.
2. Measure suction pressure by attaching a gage to outdoor unit suction valve service port. (See Fig. 32 for correct service port location on cooling cycle.)
3. Measure outdoor (coil inlet) air dry-bulb temperature with service thermometer.
4. Using a sling psychrometer, measure wet-bulb

5. Refer to correct Charging Chart. Locate on curves where outdoor air dry-bulb and indoor air wet-bulb temperature lines intersect.
6. From intersect point, project vertically downward to chart suction pressure line. Compare chart suction pressure to unit suction pressure (Step 2).
7. If unit suction pressure is lower than chart pressure, add refrigerant to system until chart pressure is reached. If unit suction pressure is higher than chart pressure, remove refrigerant until chart pressure is reached.

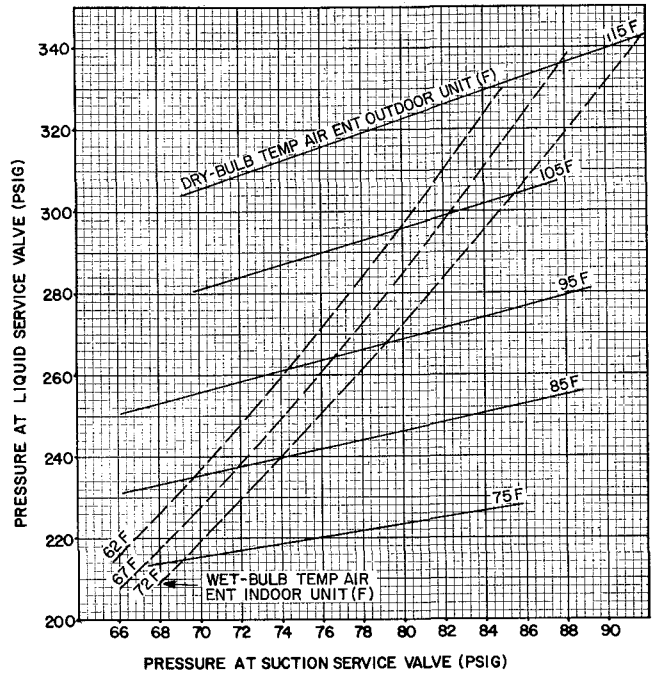
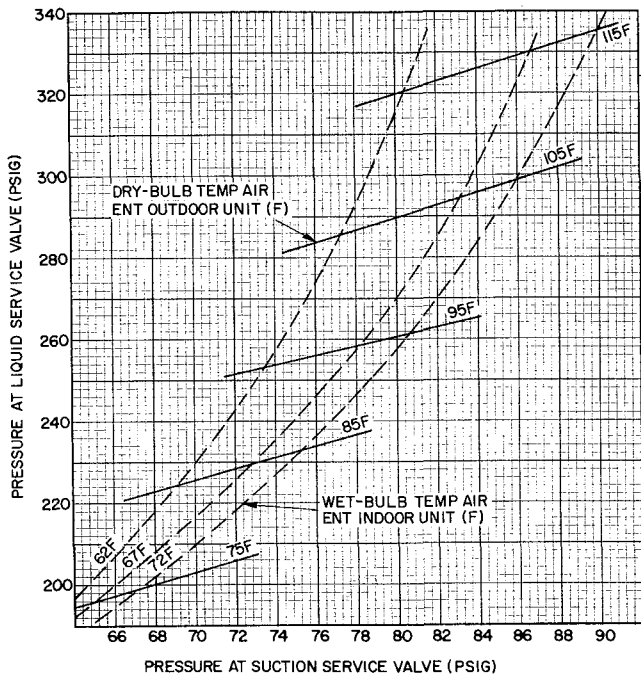

→ Fig. 9 – 38CQ015 with 40AQ018 Cooling Cycle Charging Chart (R-22)

Fig. 11 – 38CQ020 with 40AQ024 Cooling Cycle Charging Chart (R-22)

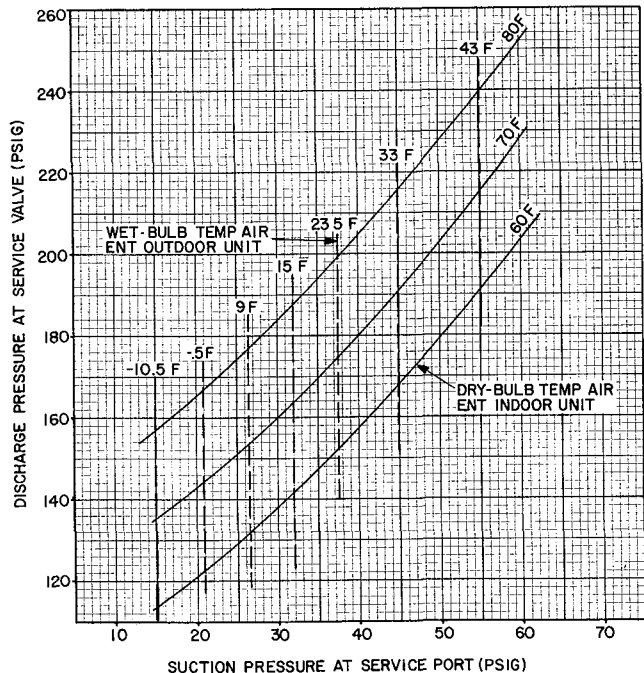
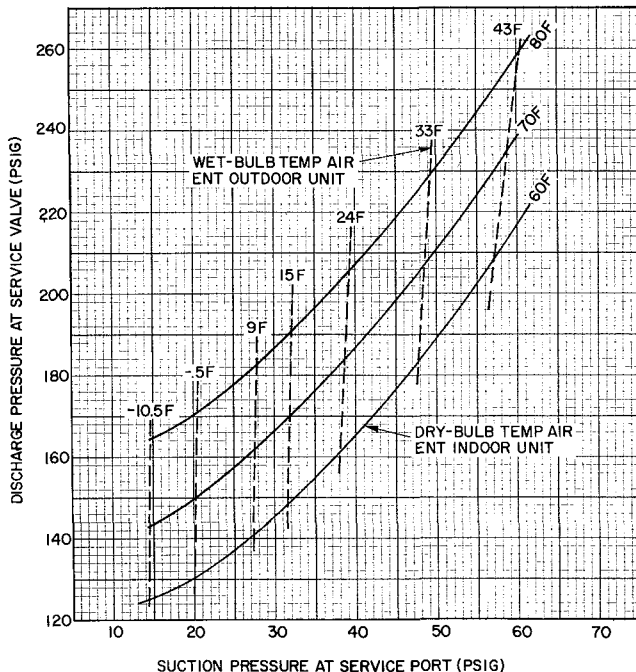

→ Fig. 10 – 38CQ015 with 40AQ018 Heating Cycle Operation Check Chart (R-22)

Fig. 12 – 38CQ020 with 40AQ024 Heating Cycle Operation Check Chart (R-22)

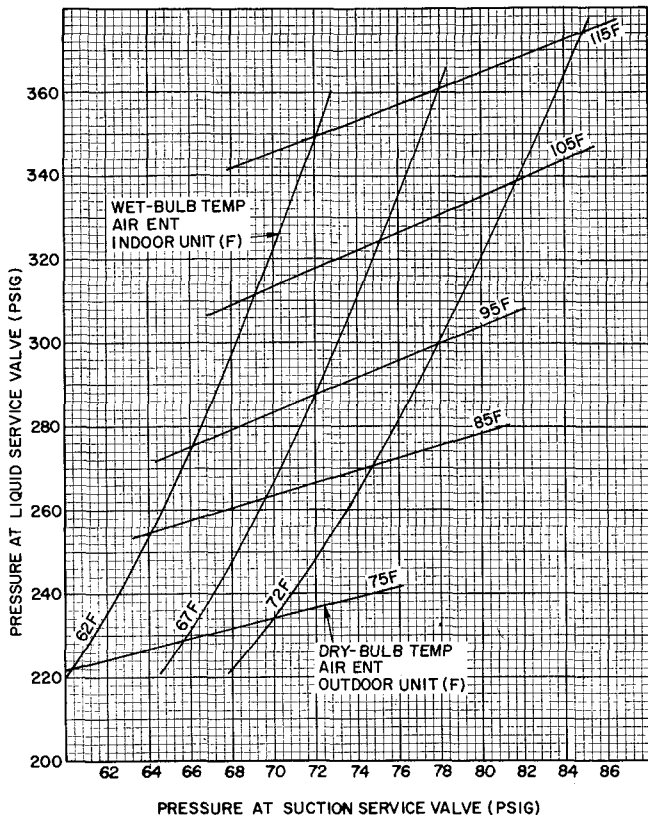

Fig. 13 – 38CQ027 with 40AQ024 Cooling Cycle Charging Chart (R-22)

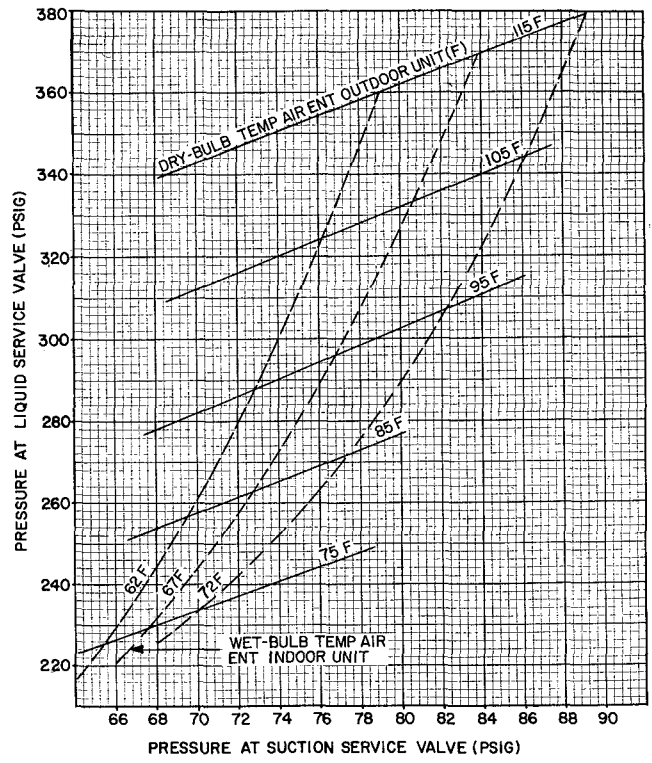

Fig. 15 – 38CQ027 with 40AQ030 Cooling Cycle Charging Chart (R-22)

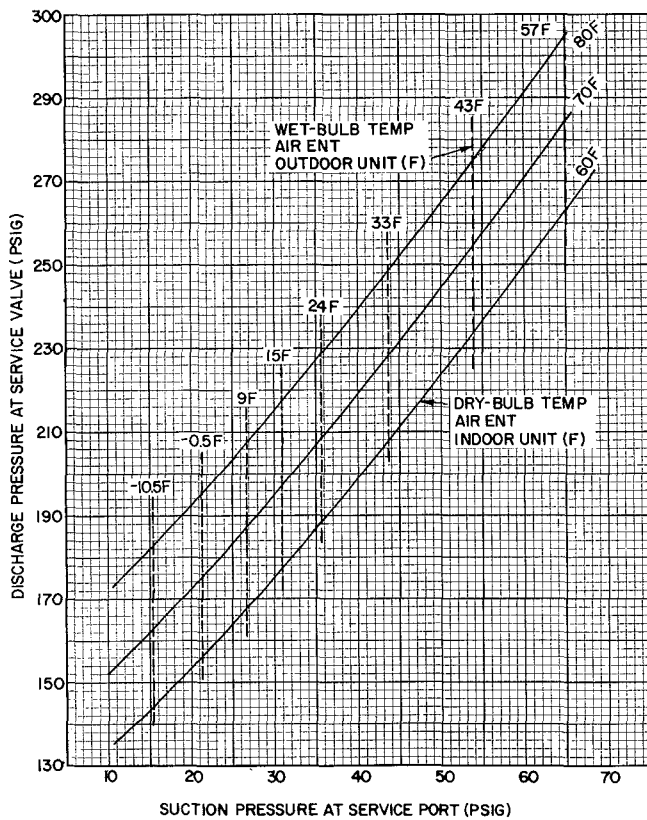

Fig. 14 – 38CQ027 with 40AQ024 Heating Cycle Operation Check Chart (R-22)

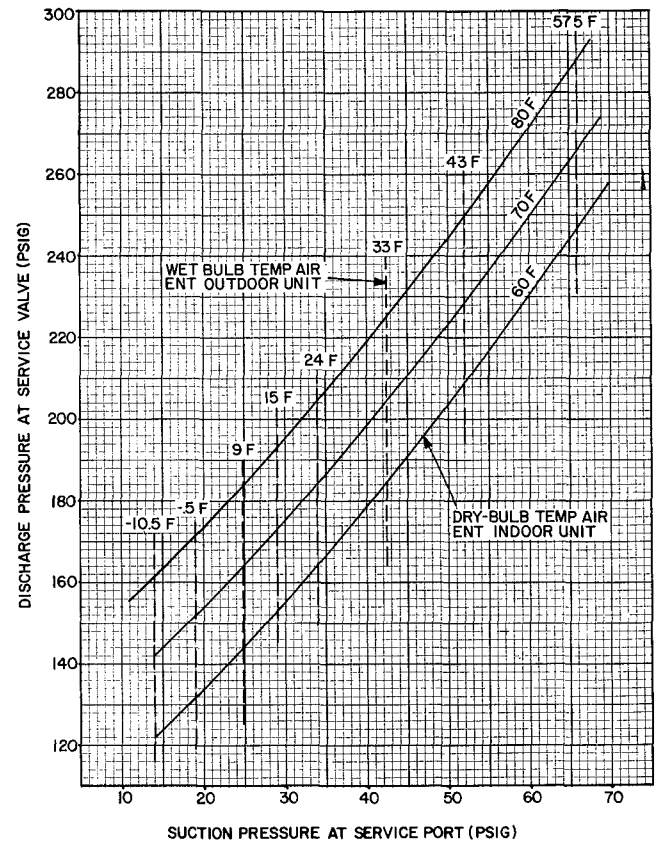

Fig. 16 – 38CQ027 with 40AQ030 Heating Cycle Operation Check Chart (R-22)

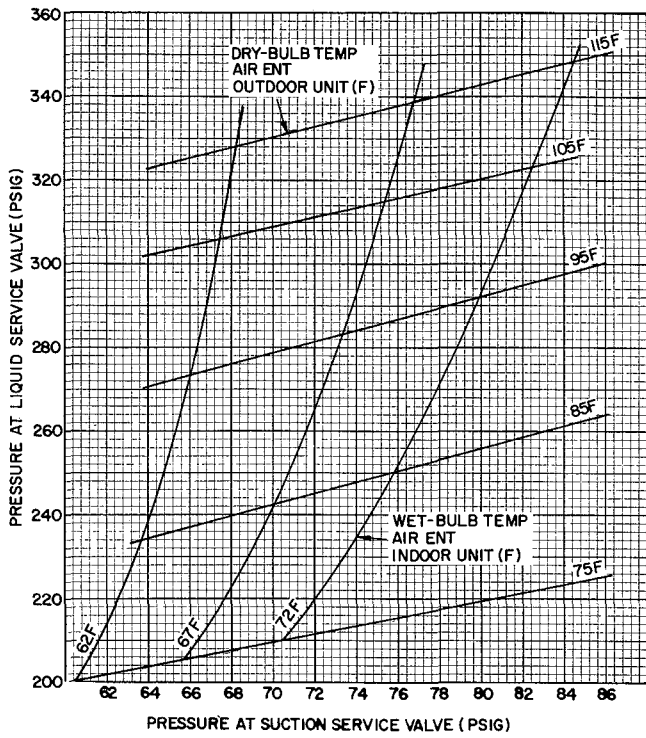

Fig. 17 – 38CQ033 with 40AQ030 Cooling Cycle Charging Chart (R-22)

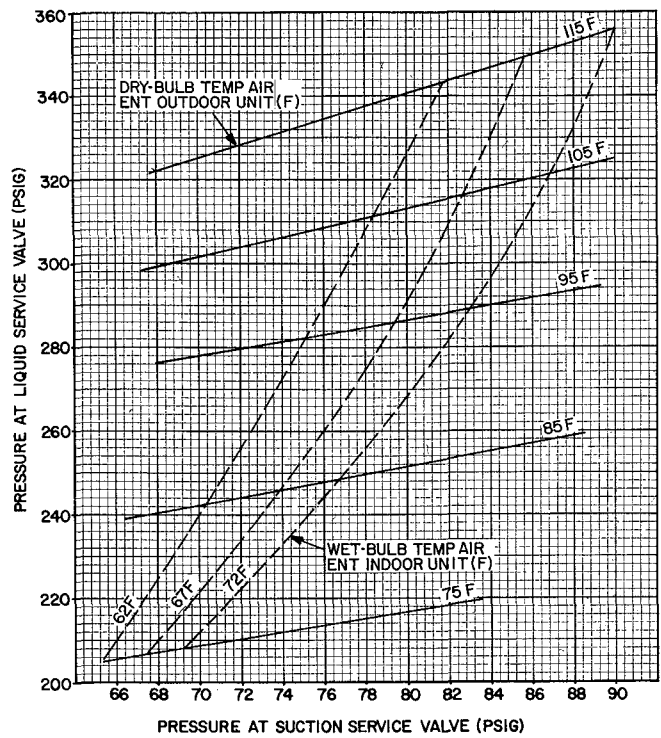

Fig. 19 – 38CQ033 with 40FS160/28MQ036 or 40AQ036 Cooling Cycle Charging Chart (R-22)

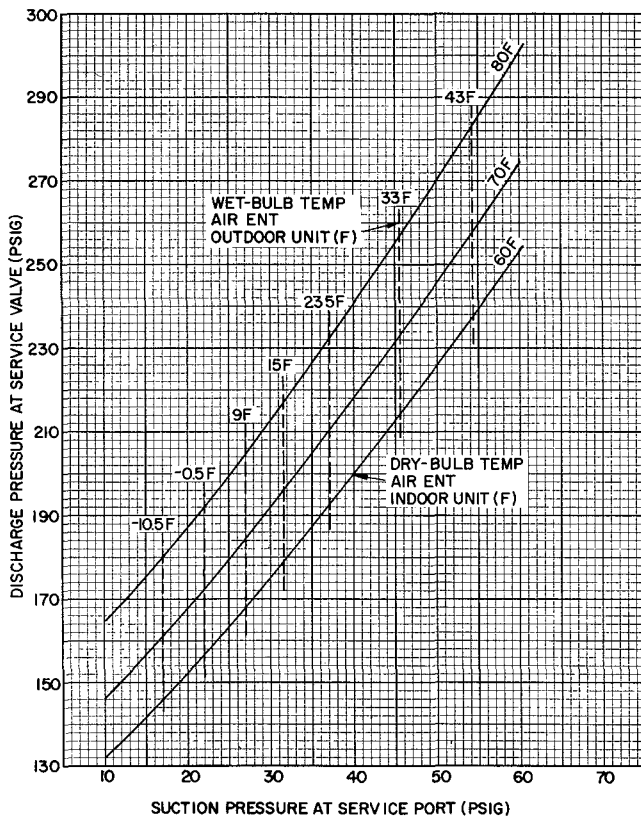

Fig. 18 – 38CQ033 with 40AQ030 Heating Cycle Operation Check Chart (R-22)

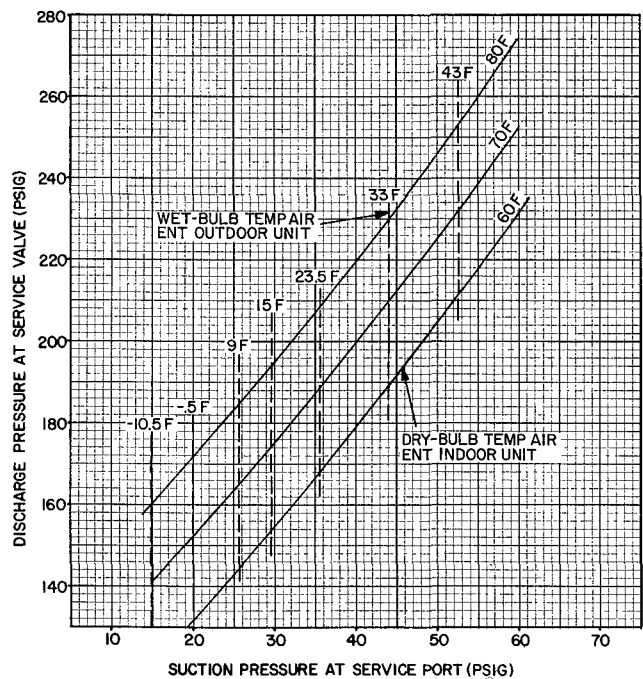

Fig. 20 – 38CQ033 with 40FS160/28MQ036 or 40AQ036 Heating Cycle Operation Check Chart (R-22)

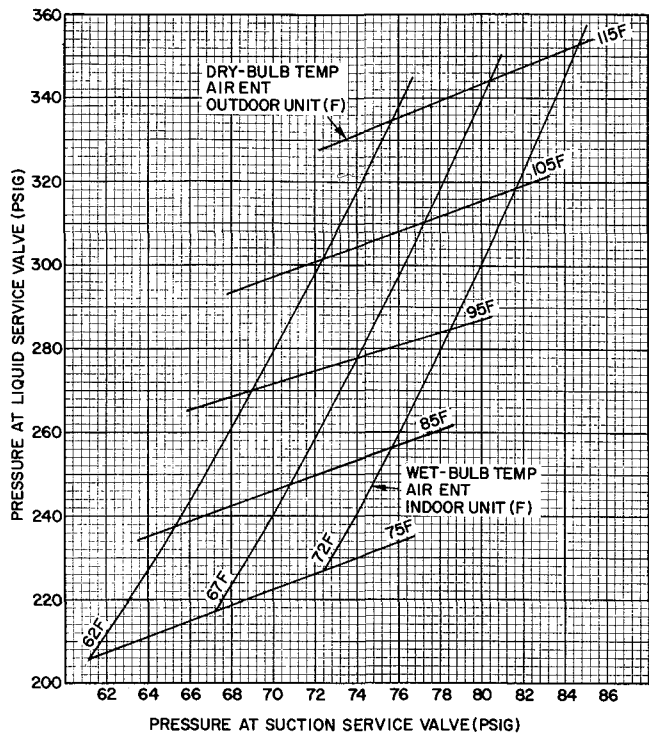

Fig. 21 – 38CQ039 with 40AQ036 or 40FS160/28MQ036 Cooling Cycle Charging Chart (R-22)

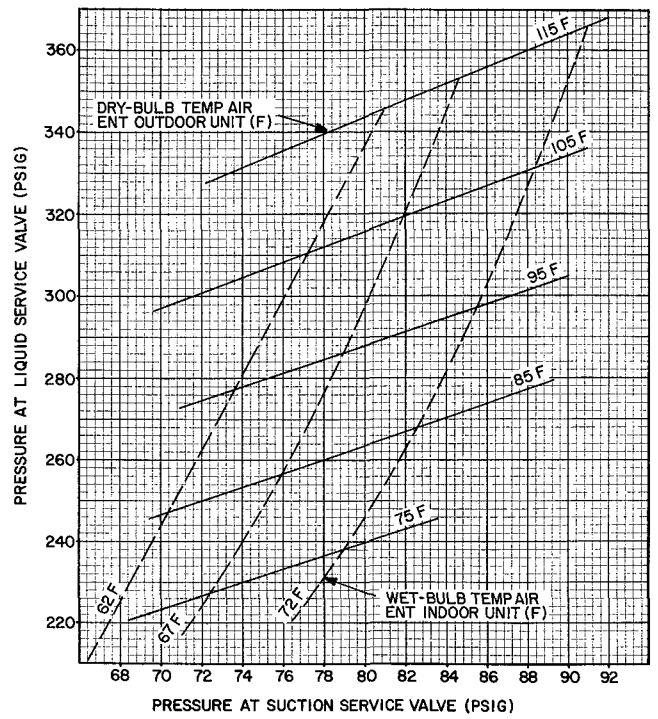

Fig. 23 – 38CQ039 with 40FS160/28MQ042 Cooling Cycle Charging Chart (R-22)

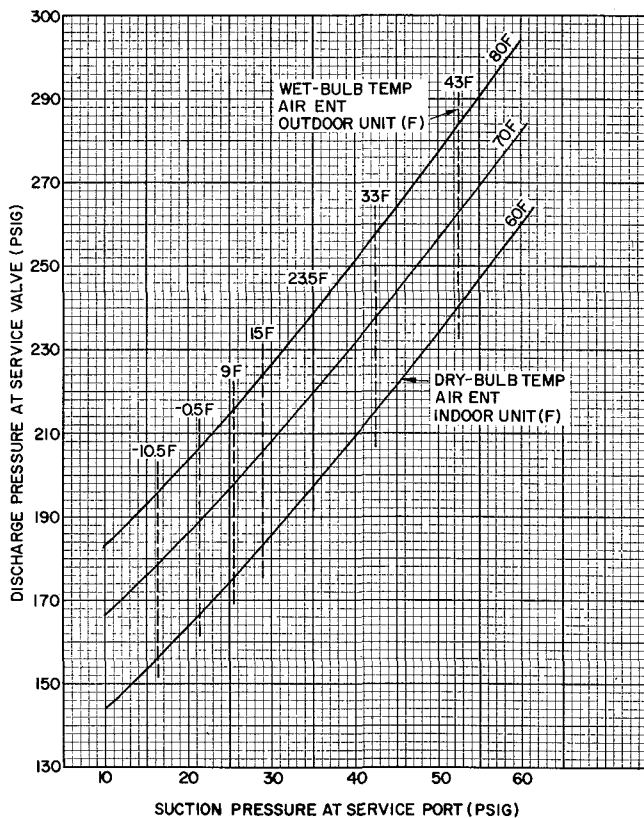

Fig. 22 – 38CQ039 with 40AQ036 or 40FS160/28MQ036 Heating Cycle Operation Check Chart

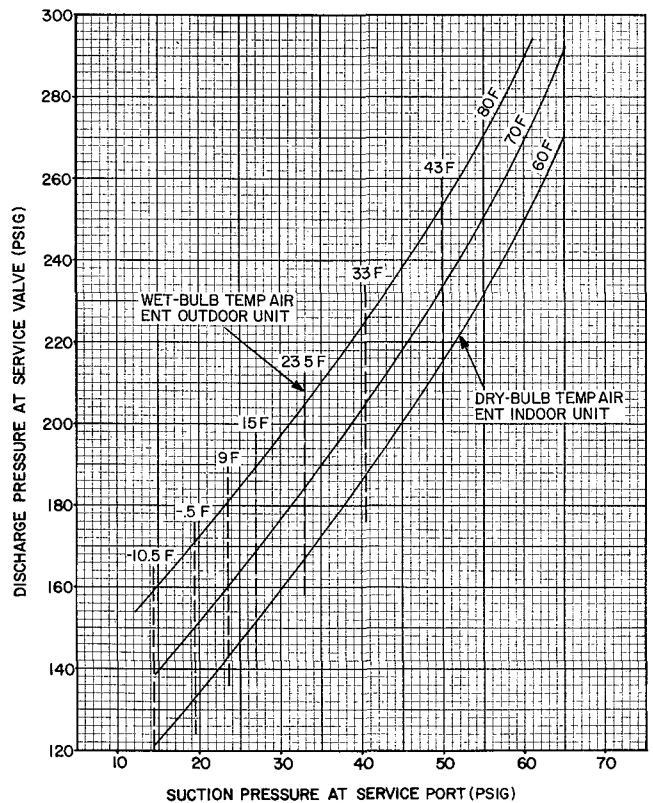
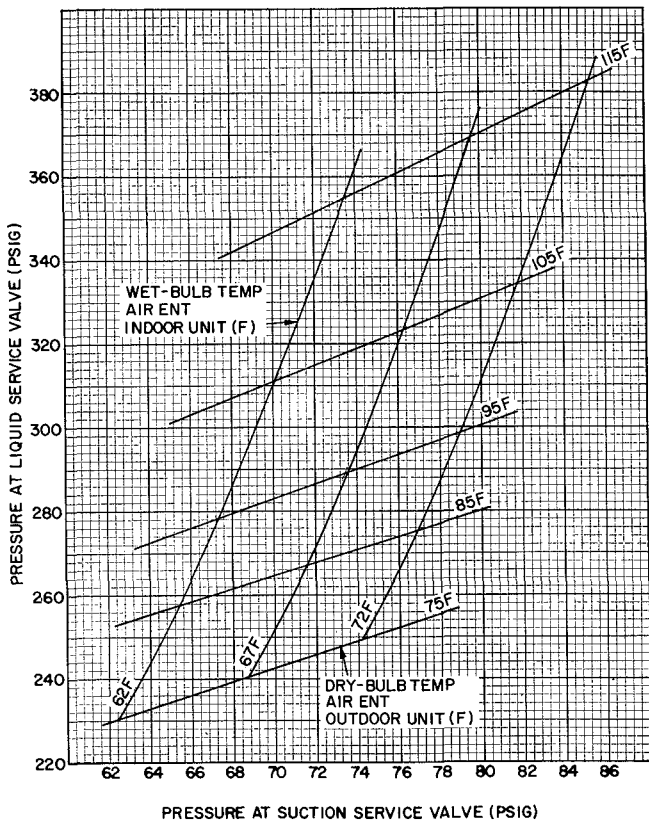
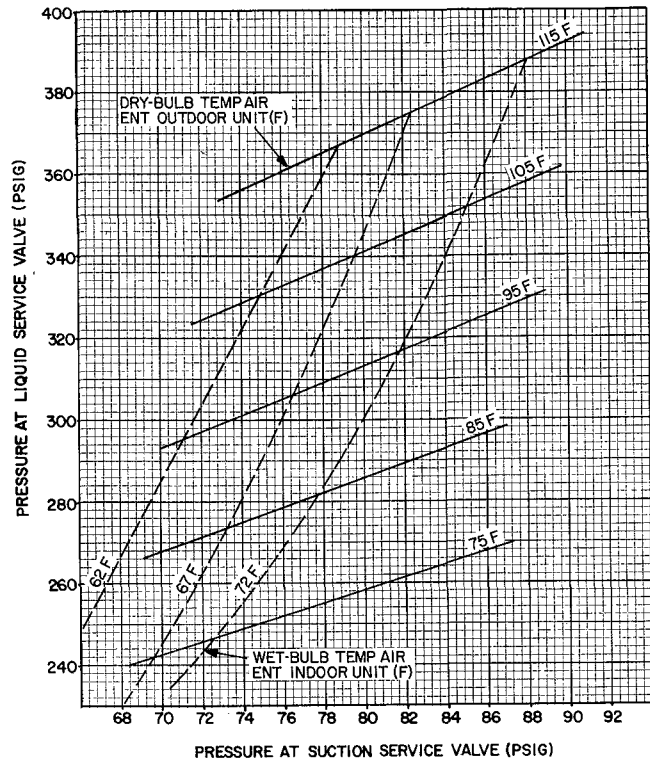

Fig. 24 – 38CQ039 with 40FS160/28MQ042 Heating Cycle Operation Check Chart (R-22)



**Fig. 25 – 38CQ044 with 40FS160/28MQ042
Cooling Cycle Charging Chart (R-22)**



**Fig. 27 – 38CQ044 with 40FS200/28MQ048
Cooling Cycle Charging Chart (R-22)**

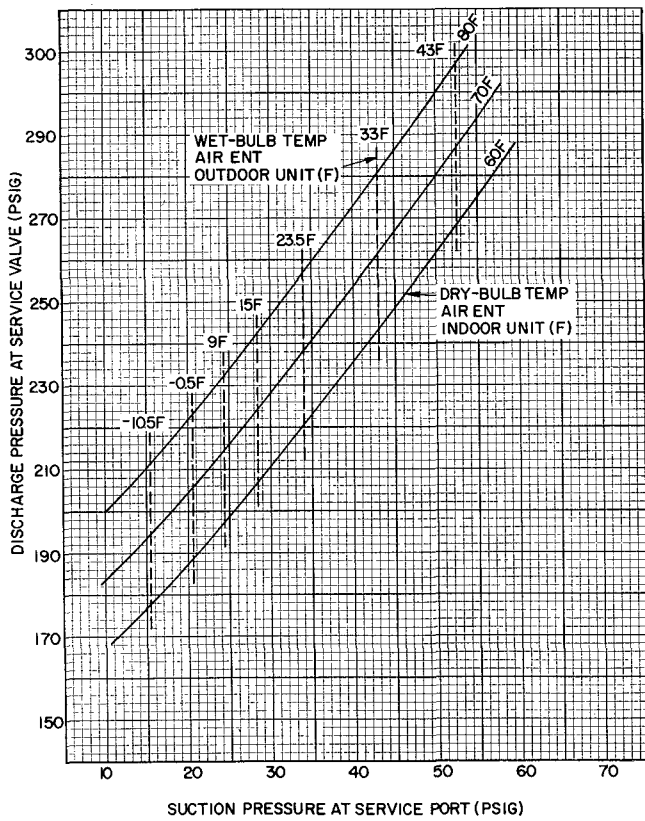

**Fig. 26 – 38CQ044 with 40FS160/28MQ042
Heating Cycle Operation Check Chart (R-22)**

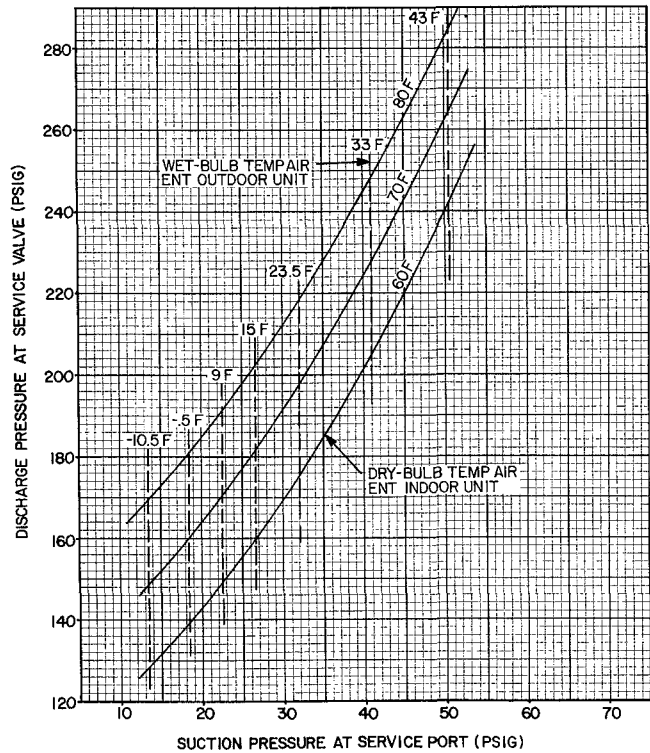

**Fig. 28 – 38CQ044 with 40FS200/28MQ048
Heating Cycle Operation Check Chart (R-22)**

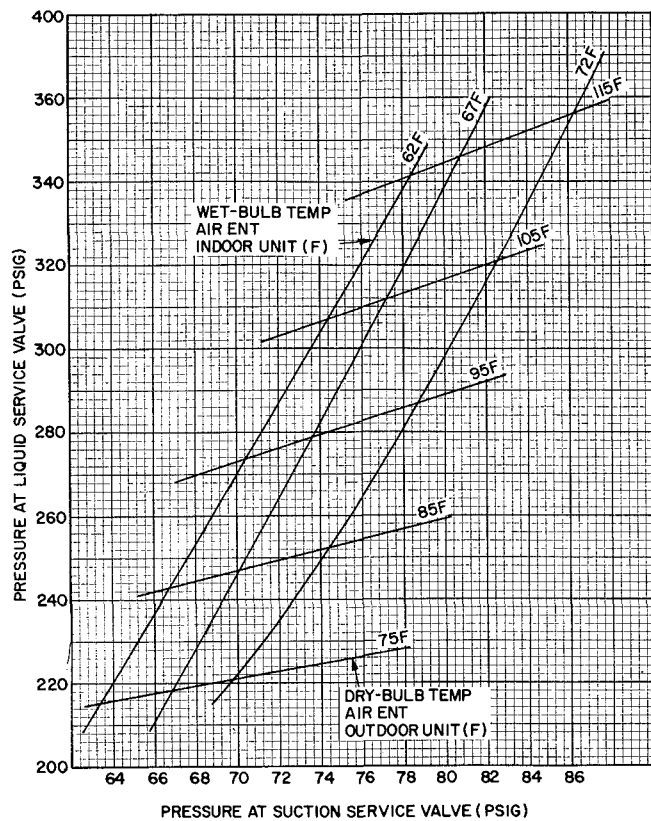

Fig. 29 — 38CQ048 with 40FS200/28MQ048 Cooling Cycle Charging Chart (R-22)

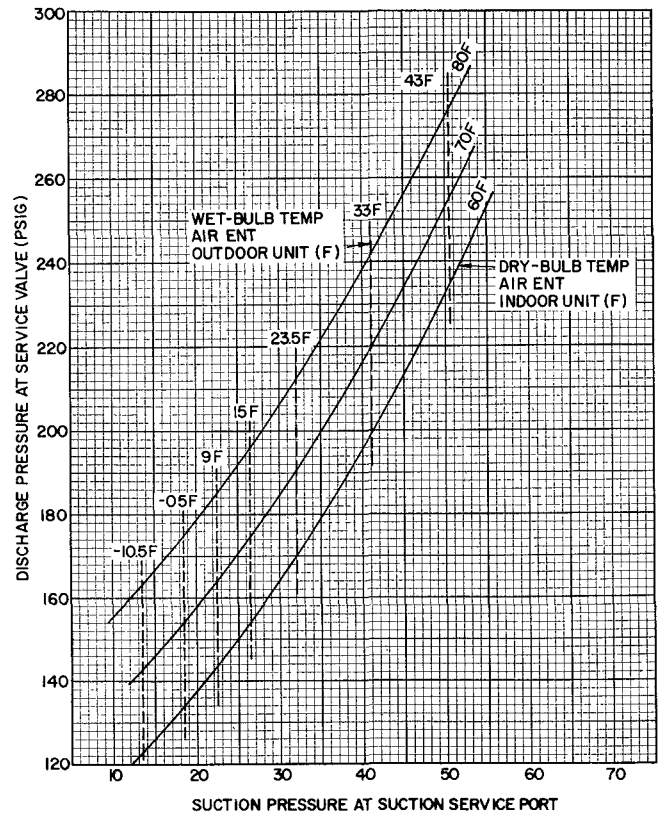

Fig. 30 — 38CQ048 with 40FS200/28MQ048 Heating Cycle Operation Check Chart (R-22)

Unit Single-Phase Compressors

COMPRESSORS OF THE SPLIT CAPACITOR (PSC) TYPE require an equalized system pressure to start. When supply voltage is within 10% limit and compressor does not start, give compressor a temporary capacitance boost. See Carrier Standard Service Techniques Manual, Chapter 2, for details. Use a 130-mfd start capacitor. Connect wires with insulated probes to each capacitor terminal. Touch probes to each side of run capacitor or to compressor motor terminals R and S. Start compressor; *pull probes away after 3 seconds Discharge start capacitor.* Run compressor for 10 minutes, then shut off and allow system pressure to equalize. Try restarting without boost capacitor. If after 2 attempts (without boost capacitor) the compressor does not start, add an accessory start thermistor (PTC device). If after 2 more attempts the compressor does not start, remove thermistor and add an accessory start capacitor relay package. COMPRESSORS THAT ARE EQUIPPED WITH A COMPRESSOR START THERMISTOR (PTC device): if compressor does not start, check the thermistor with an ohmmeter as described below. Earlier unit models have a 50-ohm thermistor (with 2-prong connections), later models have a 25-ohm

thermistor (with 3-prong connections). If indoor coil does not have a bleed-type expansion device, it may be necessary to remove start thermistor and replace with accessory start capacitor and relay.

Checking Start Thermistor

1. Shut off all power to unit and wait 5 minutes for thermistor to cool to outdoor temperature.
2. Measure resistance of thermistor with ohmmeter. Normal resistance readings at 75 F outdoor temperature are: 50 to 90 ohms for 50 ohm thermistor; 25 to 50 ohms for 25 ohm thermistor.
3. If ohmmeter resistance reading is 0 or much higher than 50 or 90 ohms, the thermistor is defective and must be replaced.

If start thermistor is good and compressor does not start, disconnect the thermistor from starting circuit and give compressor a temporary capacitance boost as described above. Run compressor for 10 minutes, then shut off and allow system pressure to equalize. Reconnect start thermistor and try restarting compressor without boost capacitor. If after 2 attempts the compressor does not start, remove thermistor and add an accessory start capacitor relay package.

Compressor Removal — See Table 7 for compressor information and Fig. 31 for component location. Follow safety codes, and wear safety glasses and work gloves. Have quenching cloth available (Step 7).

CAUTION: Aluminum tubing is used in 38CQ unit coils. Do not overheat or place excessive strain on tubing or damage may result.

1. Shut off power to unit. Remove unit top access cover and rear access wrapper.
2. Remove refrigerant from unit using refrigerant removal methods described in Carrier Standard Service Techniques Manual, Chapter 1.
3. Disconnect compressor wiring at compressor terminal box.
4. Using a tubing cutter, cut suction and discharge lines at convenient place near compressor for easy reassembly to new compressor with copper slip couplings.

CAUTION: Excessive movement of copper lines at compressor may cause a break where lines connect to 38CQ coil.

5. Remove crankcase heater from compressor base.
6. Remove compressor hold-down bolts and lift compressor out.
7. Carefully unbraze suction and discharge line piping stubs from compressor. If oil vapor in piping stubs ignites, use quenching cloth.
8. Braze piping stubs (removed in step 7) on new compressor.
9. Clean system. Add new liquid line *heat pump* filter-drier as described below.
10. Install new compressor in unit. Braze suction and discharge lines to compressor piping stubs (at points where cut, step 4) using field-supplied copper couplings. Make sure com-

pressor hold-down bolts are in place. Connect wiring.

11. Evacuate and recharge unit.

FILTER-DRIER — Install *accessory* heat pump filter-drier (Table 3) in system liquid line when refrigerant system is opened for service as described under Compressor Removal. Position drier in liquid line at convenient location. Do not use a standard single-pass filter-drier.

Table 7 — Compressor Data

UNIT	V/PH	PRODUCTION COMPRESSOR	
		Model*	Oil Recharge (oz)
→ 38CQ015	230/1	38CQ400994	20
38CQ020		MD2023HB	44
38CQ027		MD3023HB	44
38CQ033		MC3423HB	44
38CQ039		PC4616HD	64
38CQ044		PC5316HD	64
38CQ048		PC5316HD	64
38CQ039	200/3	PF4616HD	64
38CQ044		PF5316HD	64
38CQ048		PF5316HD	64
38CQ039	230/3	PG4616HD	64
38CQ044		PG5316HD	64
38CQ048		PG5316HD	64

*Refer to Service Parts catalog for replacement compressor model numbers

Pumpdown Procedure (Cooling Cycle) — The 38CQ units may be pumped down in order to make repairs on low side of system without losing complete refrigerant charge. Ensure unit is in cooling mode.

1. Attach pressure gage to suction service valve service port.
2. Frontseat the liquid line valve.
3. Start unit and run until suction pressure reaches 5 psig (see Caution).
4. Shut unit off and frontseat suction valve.
5. Vent remaining pressure to atmosphere.

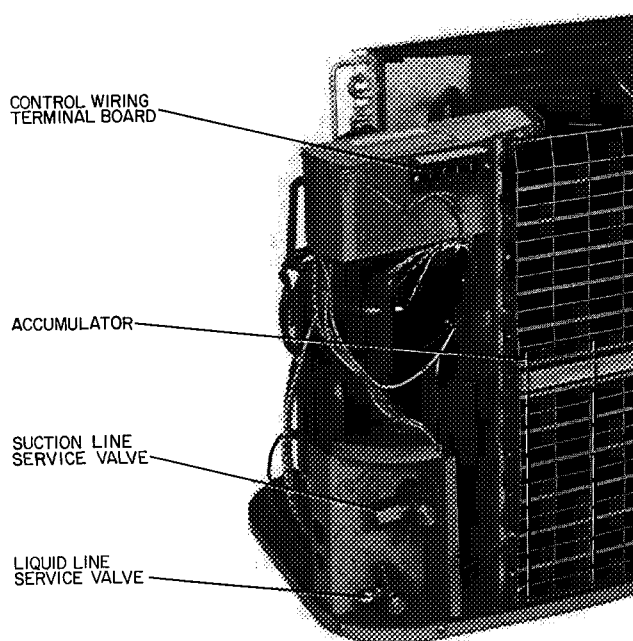
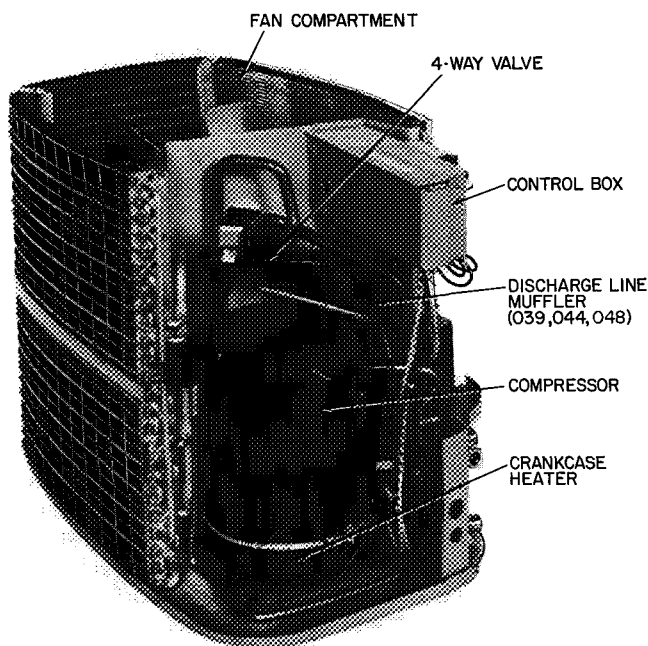

Fig. 31 — Component Location

CAUTION: 38CQ unit coils will hold only factory-supplied amount of refrigerant. Additional refrigerant may cause units to relieve pressure thru internal pressure relief valve (indicated by a sudden rise of suction pressure) before suction pressure reaches 5 psig. If this occurs, shut off unit immediately, frontseat suction valve and vent remaining pressure to atmosphere.

Unit Controls and Safety Devices

HIGH-PRESSURE RELIEF VALVE is located in compressor. Relief valve opens at a pressure differential of approximately 600 psi between suction (low side) and discharge (high side) to allow pressure equalization.

INTERNAL CURRENT AND TEMPERATURE SENSITIVE OVERLOAD resets automatically when internal compressor motor temperature drops to a safe level (overloads may require up to 45 minutes to reset). When an internal overload is suspected of being open, check by using an ohmmeter or continuity tester. If necessary, refer to Carrier Standard Service Techniques Manual, Chapter 2, for complete instructions.

LIQUID LINE LOW-PRESSURE SWITCH (LLPS) is connected in liquid line to work with compressor internal thermostat in providing loss-of-charge protection during the heating cycle. Control is mounted on liquid line.

With a high-side leak, pressure gradually decreases until low-pressure control stops the compressor. (Low-pressure control settings are shown in Table 8.)

→ **Table 8 — Pressure Switch Settings**

UNIT 38CQ	LIQUID LINE LOW-PRESSURE SWITCH	
	Cut-in (psig)	Cutout (psig)
015	20 ± 5	5 ± 3
020		
027		
033		
039		
044		
048		

With a low-side leak there is always some pressure in the liquid line. However, compressor motor temperature increases because of insufficient suction gas cooling. This causes internal thermostat to actuate and stop compressor. When compressor stops, system pressure equalizes and contacts on pressure control open. The compressor cannot restart until leak is repaired and system recharged.

CRANKCASE HEATER is connected across line side of contactor and operates continuously.

The purpose of the heater is to keep the crankcase warm during the off cycle and thus prevent dilution of the oil with refrigerant. This assures good lubrication and prevents loss of oil from crankcase during start-up.

If the electrical disconnect switch to the outside unit has been off for an extended period of time, the crankcase heater should be energized for 24 hours before starting the compressor

DEFROST CONTROL, consisting of a defrost timer, defrost thermostat and defrost relay, interrupts normal system heating operation every 90 minutes to defrost outdoor coil, *if the coil saturated suction temperature indicates freezing temperatures*. Defrost control simultaneously stops outdoor fan, energizes reversing valve solenoid to return system to cooling cycle (outdoor unit as condenser, indoor unit as evaporator), and activates accessory electric heater.

For the heat pump to defrost, 2 conditions are necessary:

1. Defrost timer contacts must be closed.
2. Refrigerant temperature from outdoor unit must be cold enough to cause defrost thermostat contacts to close. Contacts close at 31 (±4) F.

Every 90 minutes of elapsed running time, the defrost timer contacts close for 10 seconds. If the defrost thermostat contacts are closed, the unit defrosts. The defrost timer limits defrosting period to 10 minutes. Normally the frost is removed and the defrost thermostat contacts will open to terminate defrosting before 10 minutes have elapsed. Defrost thermostat contacts open at 80 (±6) F liquid refrigerant temperature. When defrosting is terminated, the outdoor fan motor is energized and reversing valve solenoid is de-energized returning unit to heating cycle.

HEAT PUMP CIRCUITS shown in Fig. 32 are refrigerant flow diagrams for heating and cooling cycles.

AccuRater™ (Bypass Type) Servicing — See Fig. 33 for bypass type AccuRater components. The piston has a refrigerant metering hole thru it. The retainer forms a stop for the piston in the refrigerant bypass mode, and a sealing surface for liquid line flare connection. To check, clean or replace piston:

1. Shut off power to unit.
2. Pump unit down using Pumpdown Procedure described previously.
3. Remove liquid line flare connection from AccuRater.
4. Pull retainer out of body being careful not to scratch flare sealing surface. If retainer does not pull out easily, carefully use vise grips or pliers to remove retainer.
5. Slide piston out by inserting a small soft wire, with small kinks, thru metering hole. Ensure metering hole, sealing surface around piston cones and fluted portion of piston are not damaged.

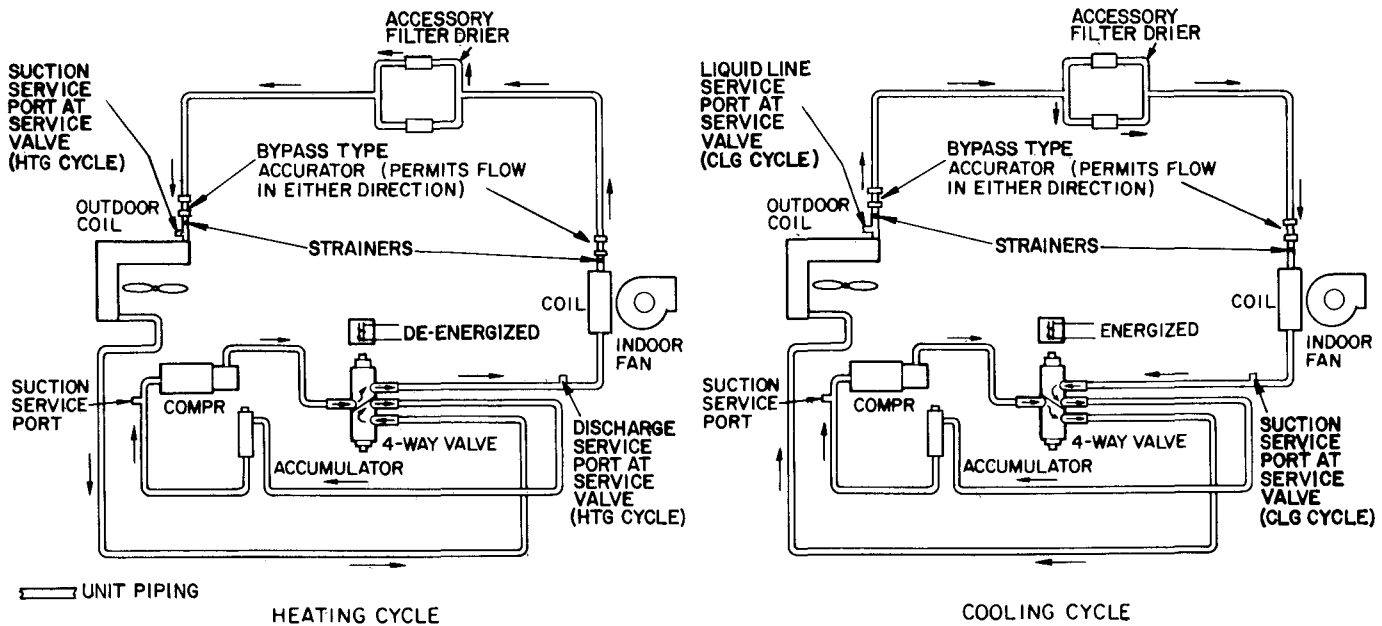

→ Fig. 32 – 38CQ Refrigerant Flow Diagrams

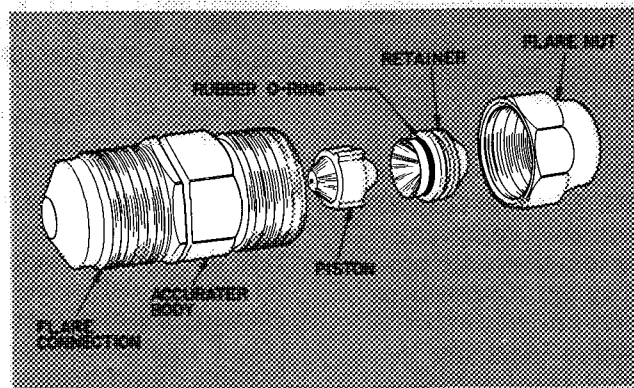

Fig. 33 – AccuRater™ (Bypass Type) Components

6. Clean piston refrigerant metering hole.
7. Replace retainer O-ring before reassembling bypass type AccuRater. Carrier O-ring part no. is 99CC501052.

LIQUID LINE STRAINER (protects AccuRater) made of wire mesh is located in the liquid line inside 38CQ unit behind liquid line service valve. Liquid line is belled and sweat connected where strainer is located. If strainer is plugged, unsweat belled liquid line connection and replace strainer.

Compatible Fitting Repair

LEAKING MECHANICAL CONNECTION – Frontseat outdoor section service valves and relieve refrigerant pressure in tubing. Back locknut off Carrier Compatible Fitting onto tube. Cut fitting between threads and seal ring bead shown in Fig. 34. Remove tubing section remaining in threaded portion of fitting. Discard locknut.

Clean, flux, and insert new tube end into remaining portion of Carrier Compatible Fitting. *Wrap valve base in wet rag.* Heat and apply low-temperature solder (450 F).

LEAKING SWEAT CONNECTION – Frontseat service valves and relieve refrigerant pressure in tubing. Clean and flux area around leak and apply low-temperature solder (450 F).

Evacuate or purge indoor coil and tubing system. Add refrigerant charge (see charging instructions).

Leaking Flare Connection – Cut and reflare 3/8-in. system liquid line.

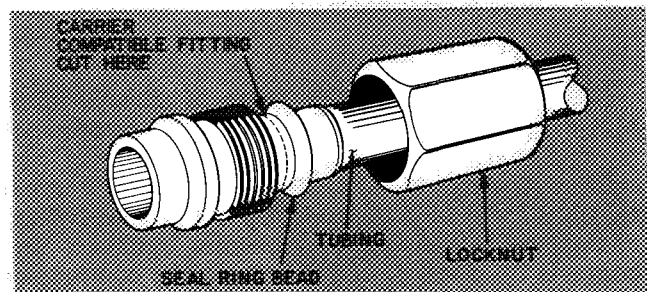

Fig. 34 – Carrier Compatible Fitting

Outdoor Fan Position — Required fan position is shown in Fig. 35. Adjust fan by loosening setscrew and moving fan blades up or down.

Fan Motor Removal

1. Shut off power to unit.
2. Remove unit top access cover and fan grille.
3. Disconnect fan motor wires from fan capacitor and control relay or contactor. Pull wires out of control box.
4. Remove fan from motor shaft by loosening setscrew and pulling upward on fan hub.
5. Remove rain shield from motor shaft by pulling upward.
6. Loosen bolt holding fan motor to motor mounting bracket. Remove motor thru top of unit. To replace motor, place motor on self-positioning motor mounting flanges and re-tighten bolt.

Before replacing fan, ensure rain protector is in place on motor shaft.

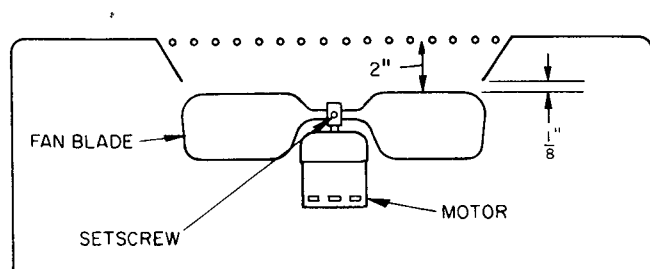

Fig. 35 — Condenser Fan Position

MAINTENANCE

CAUTION: Ensure power is off to unit before performing required maintenance.

Outdoor Coil Cleaning — Inspect coil periodically. Clean coil with water at the beginning of every cooling season or more often if required. Use ordinary garden hose at a pressure high enough to clean efficiently. For best results, unscrew and remove unit top cover (grille). Insert hose nozzle between fan blades and spray coil fins from inside-to-outside the unit or top to bottom between rows of tubing. If unit has a double-row coil, loosen screws to separate coils. Pull outer row of coils away from inner row and flush dirt toward outside of both coils. Flush dirt from base pan by spraying water thru top of unit. Avoid splashing mud on coil or water on fan motor. Make sure water drainage holes under outdoor coil are not obstructed.

Lubrication

FAN MOTOR BEARINGS — Oiling holes are provided at each end of outdoor unit fan motor. Remove fan motor and lubricate motor with 32 drops (16 drops per hole) of SAE-10 nondetergent oil at intervals described below:

- a. Annually, when environment is very dirty, ambient temperature is higher than 105 F and average unit operating time exceeds 15 hours a day.
- b. Every 3 years when environment is reasonably clean, ambient temperature is less than 105 F and unit operating time averages 8 to 15 hours a day.
- c. Every 5 years when environment is clean, ambient temperature is less than 105 F and unit operating time averages less than 8 hours a day.

COMPRESSOR contains factory oil charge. When oil is lost, see Table 7 for oil charge and Carrier Standard Service Techniques Manual, Chapter 1, page 1-21, for instructions. Use Carrier PP33-1, Texaco Capella B or Suniso 3G oil.

TROUBLESHOOTING CHART -- COOLING CYCLE

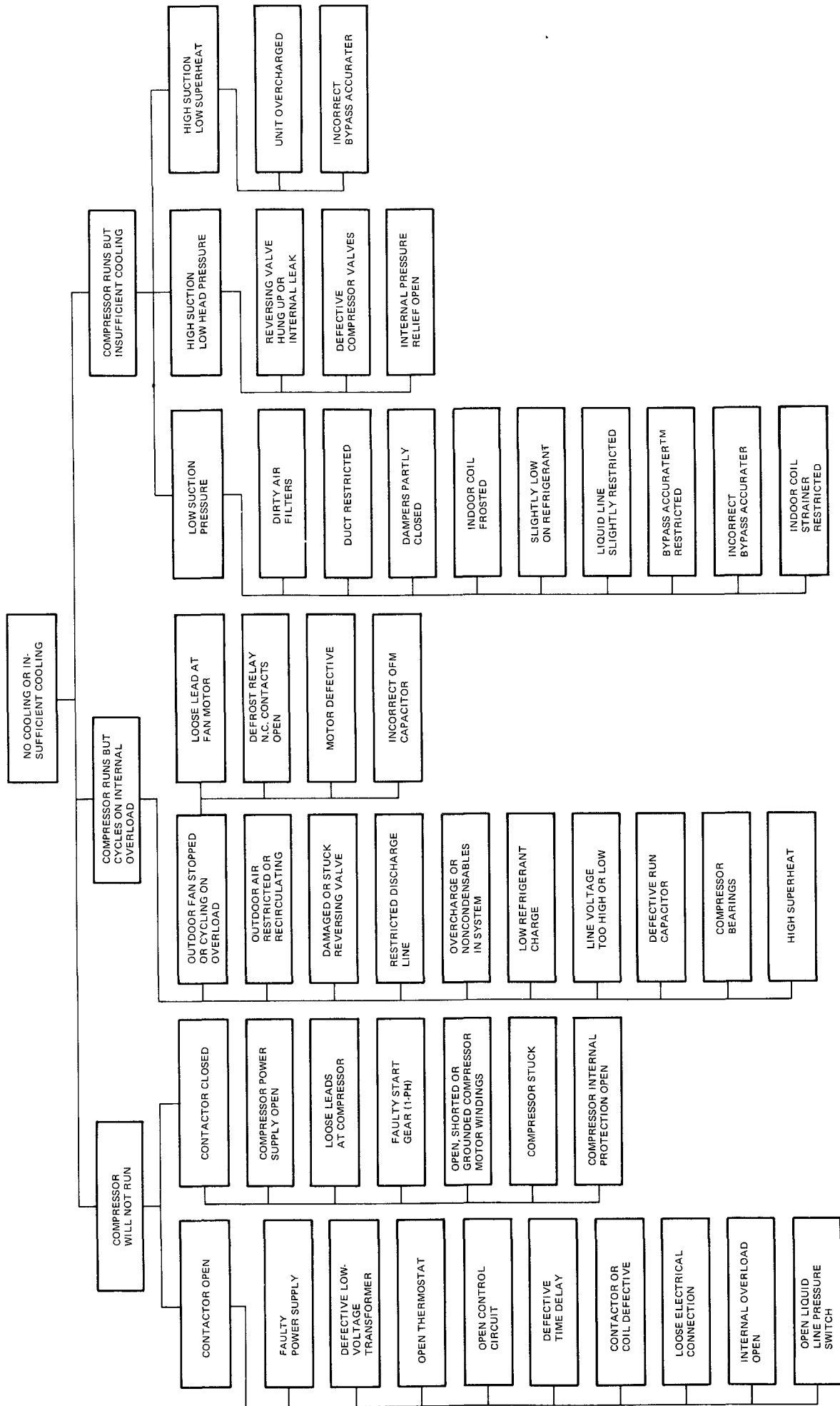

TROUBLESHOOTING CHART -- HEATING CYCLE

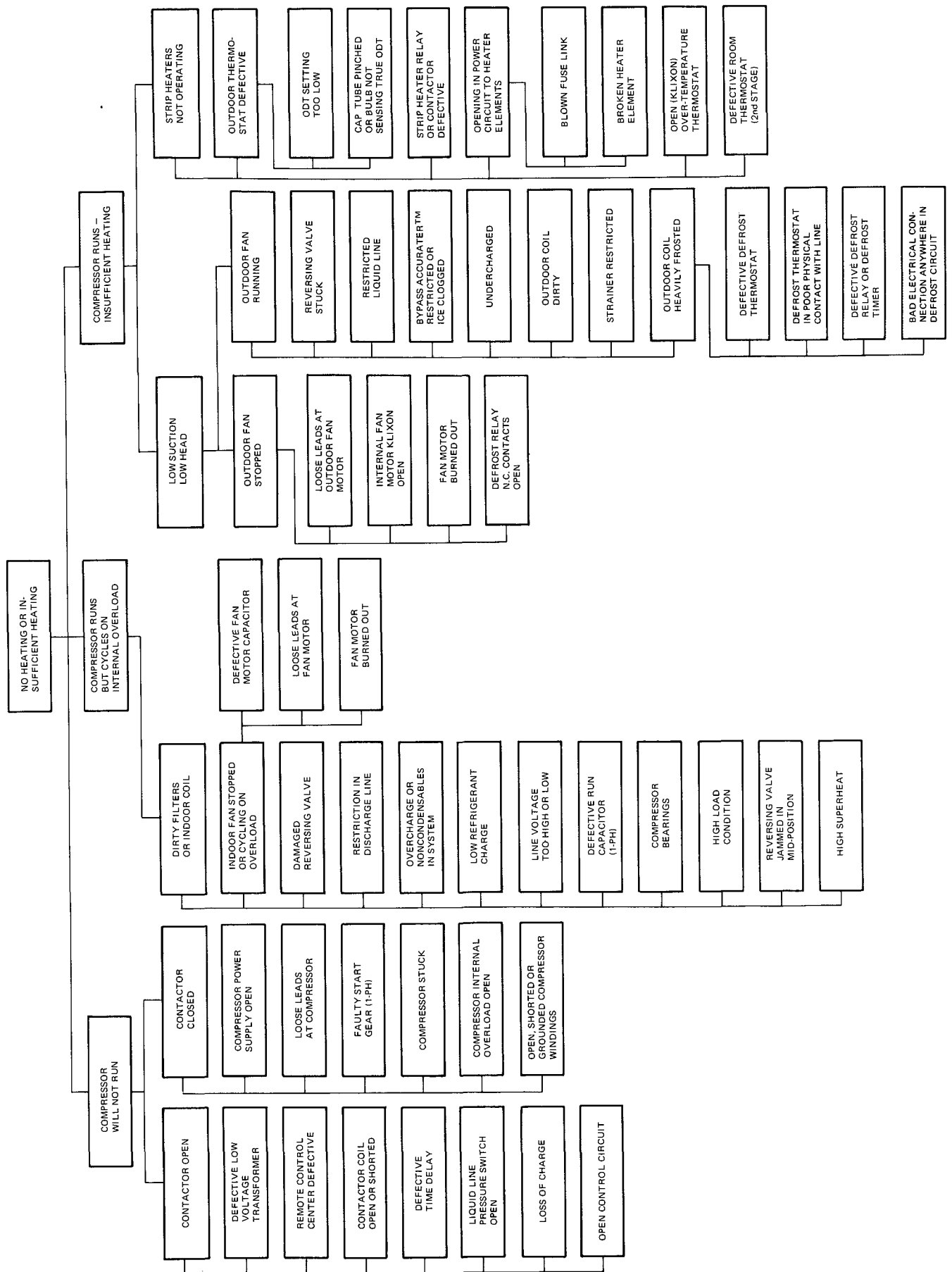

SI METRIC CONVERSIONS

$(^{\circ}\text{F} - 32) \times 5/9$		= $^{\circ}\text{C}$
BTU x	1.055	= kJ
BTU/hr x	0.2931	= W
Tons refriger x	3.517	= kW
HP x	0.7457	= kW
kcal/hr x	1.163	= W
ft x	0.3048	= m
ft ² x	0.09290	= m ²
fpm	0.005080	= m/s
in x	25.4	= mm
in wg 39.2 $^{\circ}\text{F}$ x	0.2491	= kPa
in Hg 32 $^{\circ}\text{F}$ x	3.386	= kPa
CFM x	0.0004719	= m ³ /s
gpm (U.S.) x	0.06309	= l/s
lb x	0.4536	= kg
lb/in ² x	6.895	= kPa
oz. x	0.02835	= kg
fluid oz. (U.S.) x	0.02957	= l
kcal x	4.1855	= kJ
kg f/cm ² x	98.07	= kPa
Metric HP x	735.5	= W
pints x	0.4732	= l

For replacement items use Carrier Specified Parts.

Manufacturer reserves the right to discontinue, or change at any time, specifications or designs without notice and without incurring obligations.

Tab 12

Form 38CQ-6SI Supersedes 38CQ-4SI

Printed in U S A

1-77

PC 101

Catalog No 533-854

Book	1	4
Tab	5a	5a

Free Manuals Download Website

<http://myh66.com>

<http://usermanuals.us>

<http://www.somanuals.com>

<http://www.4manuals.cc>

<http://www.manual-lib.com>

<http://www.404manual.com>

<http://www.luxmanual.com>

<http://aubethermostatmanual.com>

Golf course search by state

<http://golfingnear.com>

Email search by domain

<http://emailbydomain.com>

Auto manuals search

<http://auto.somanuals.com>

TV manuals search

<http://tv.somanuals.com>