



AQUAZONE™
50PCH,PCV006-060
Compact High-Efficiency Water Source Heat Pumps
with PURON® Refrigerant (R-410A)

Installation, Start-Up, and Service Instructions

CONTENTS

	Page	Page	
SAFETY CONSIDERATIONS	1,2	Unit Start-Up Heating Mode	30
GENERAL	2	Unit Start-Up with WSHP Open Controls	30
INSTALLATION	2-22	Flow Regulation	32
Step 1 — Check Jobsite	2	Flushing	32
Step 2 — Check Unit	2	Antifreeze	32
• STORAGE		Cooling Tower/Boiler Systems	32
• PROTECTION		OPERATION	33-36
• INSPECT UNIT		Power Up Mode	33
Step 3 — Locate Unit	7	Units with Aquazone Complete C Control	33
• FIELD CONVERSION OF DISCHARGE AIR		Units with Aquazone Deluxe D Control	33
Step 4 — Mount the Unit	8	Units with WSHP Open Multiple Protocol	33
• HORIZONTAL UNITS		COMPLETE C AND DELUXE D BOARD	
• VERTICAL UNITS		SYSTEM TEST	36-38
Step 5 — Check Duct System	8	Test Mode	36
• SOUND ATTENUATION		WSHP Open Test Mode	36
• EXISTING DUCT SYSTEM		Retry Mode	37
Step 6 — Install Condensate Drain	8	Aquazone Deluxe D Control LED Indicators	37
• HORIZONTAL UNITS		SERVICE	38-40
• VERTICAL UNITS		Filters	38
• VENTING		Water Coil	38
Step 7 — Pipe Connections	9	Condensate Drain Pans	38
• WATER LOOP APPLICATIONS		Refrigerant System	38
• GROUND LOOP APPLICATIONS		Compressor	38
• INSTALLATION OF SUPPLY AND RETURN HOSE KIT		Fan Motors	38
Step 8 — Wire Field Power Supply	10	Condensate Drain Cleaning	38
• POWER CONNECTION		Air Coil Cleaning	39
• SUPPLY VOLTAGE		Condenser Cleaning	39
• 208-VOLT OPERATION		Checking System Charge	39
• 460-VOLT OPERATION		Refrigerant Charging	39
Step 9 — Wire Field Controls	20	Air Coil Fan Motor Removal	40
• THERMOSTAT CONNECTIONS		Replacing the WSHP Open Controller's Battery	40
• WATER FREEZE PROTECTION		TROUBLESHOOTING	40-42
• AIR COIL FREEZE PROTECTION		Thermistor	40
• ACCESSORY CONNECTIONS		Control Sensors	40
• WATER SOLENOID VALVES		WSHP Open Controller	40
• WSHP OPEN WIRING		APPENDIX A — WSHP OPEN SCREEN CONFIGURATION	43-48
PRE-START-UP	22,23	50PCH,PCV START-UP CHECKLIST	CL-1, CL-2
System Checkout	22		
PSC Blower Speed Selection	22		
FIELD SELECTABLE INPUTS	24,25		
Complete C Control Jumper Settings	24		
Complete C Control DIP Switches	24		
Deluxe D Control Jumper Settings	24		
Deluxe D Control DIP Switches	24		
Deluxe D Control Accessory Relay Configurations	25		
Water Valve (Slow Opening)	25		
Outside Air Damper (OAD)	25		
START-UP	25-33		
Operating Limits	25		
Scroll Compressor Rotation	26		
Unit Start-Up Cooling Mode	26		

IMPORTANT: Read the entire instruction manual before starting installation.

SAFETY CONSIDERATIONS

Installation and servicing of air-conditioning equipment can be hazardous due to system pressure and electrical components. Only trained and qualified service personnel should install, repair, or service air-conditioning equipment.

Untrained personnel can perform basic maintenance functions of cleaning coils and filters and replacing filters. All other operations should be performed by trained service personnel. When working on air-conditioning equipment, observe precautions in the literature, tags and labels attached to the unit, and other safety precautions that may apply.

Improper installation, adjustment, alteration, service, maintenance, or use can cause explosion, fire, electrical shock or other conditions which may cause personal injury or property damage. Consult a qualified installer, service agency, or your distributor or branch for information or assistance. The qualified installer or agency must use factory-authorized kits or accessories when modifying this product. Refer to the individual instructions packaged with the kits or accessories when installing.

Follow all safety codes. Wear safety glasses and work gloves. Use quenching cloth for brazing operations. Have fire extinguisher available. Read these instructions thoroughly and follow all warnings or cautions attached to the unit. Consult local building codes and the National Electrical Code (NEC) for special installation requirements.

Understand the signal words — DANGER, WARNING, and CAUTION. DANGER identifies the most serious hazards which will result in severe personal injury or death. WARNING signifies hazards that could result in personal injury or death. CAUTION is used to identify unsafe practices, which would result in minor personal injury or product and property damage.

Recognize safety information. This is the safety-alert symbol () . When you see this symbol on the unit and in instructions or manuals, be alert to the potential for personal injury.

WARNING

Electrical shock can cause personal injury or death. Before installing or servicing system, always turn off main power to system. There may be more than one disconnect switch. Turn off accessory heater power if applicable.

GENERAL

This Installation and Start-Up Instructions literature is for Aquazone™ water source heat pump systems.

Water source heat pumps (WSHPs) are single-package horizontally and vertically mounted units with electronic controls designed for year-round cooling and heating. Aquazone WSHPs are available in the following unit configurations:

- PCH standard efficiency with horizontal airflow and right, left or back discharge
- PCV standard efficiency with vertical airflow and top discharge

IMPORTANT: The installation of water source heat pump units and all associated components, parts, and accessories which make up the installation shall be in accordance with the regulations of ALL authorities having jurisdiction and MUST conform to all applicable codes. It is the responsibility of the installing contractor to determine and comply with ALL applicable codes and regulations.

INSTALLATION

Step 1 — Check Jobsite — Installation, operation and maintenance instructions are provided with each unit. Before unit start-up, read all manuals and become familiar with the unit and its operation. Thoroughly check out the system before operation. Complete the inspections and instructions listed below to prepare a unit for installation. See Table 1 for unit physical data.

HORIZONTAL UNITS (50PCH) — Horizontal units are designed for indoor installation only. Be sure to allow adequate space around the unit for servicing. See Fig. 1 for overall unit dimensions. Refer to Fig. 2 for an illustration of a typical horizontal installation.

VERTICAL UNITS (50PCV) — Vertical units are designed for indoor installations. While vertical units are typically

installed in a floor-level closet or a small mechanical room, the unit access guidelines for these units are very similar to those described for horizontal units. See Fig. 3 for overall dimensions. Refer to Fig. 4 for an example of a typical vertical installation.

CAUTION

To avoid equipment damage, do not use these units as a source of heating or cooling during the construction process. The mechanical components and filters used in these units quickly become clogged with construction dirt and debris which may cause system damage.

Step 2 — Check Unit — Upon receipt of shipment at the jobsite, carefully check the shipment against the bill of lading. Make sure all units have been received. Inspect the carton or crating of each unit, and inspect each unit for damage. Ensure the shipping company makes proper notation of any shortages or damage on all copies of the freight bill. Concealed damage not discovered during unloading must be reported to the shipping company within 15 days of receipt of shipment.

NOTE: It is the responsibility of the purchaser to file all necessary claims with the shipping company.

1. Verify unit is correct model for entering water temperature of job.
2. Be sure that the location chosen for unit installation provides ambient temperatures maintained above freezing. Well water applications are especially susceptible to freezing.
3. Be sure the installation location is isolated from sleeping areas, private offices and other acoustically sensitive spaces.
NOTE: A sound control accessory package may be used to help eliminate sound in sensitive spaces.
4. Check local codes to be sure a secondary drain pan is not required under the unit.
5. Be sure unit is mounted at a height sufficient to provide an adequate slope of the condensate lines. If an appropriate slope cannot be achieved, a field-supplied condensate pump may be required.
6. Provide sufficient space for duct connection.
7. Provide adequate clearance for filter replacement and drain pan cleaning. Do not allow piping, conduit, etc. to block filter access.
8. Provide sufficient access to allow maintenance and servicing of the fan and fan motor, compressor and coils. Removal of the entire unit from the closet should not be necessary.
9. Provide an unobstructed path to the unit within the closet or mechanical room. Space should be sufficient to allow removal of unit if necessary.
10. Provide ready access to water valves and fittings, and screwdriver access to unit side panels, discharge collar, and all electrical connections.
11. Where access to side panels is limited, pre-removal of the control box side mounting screws may be necessary for future servicing.

STORAGE — If the equipment is not needed immediately at the jobsite, it should be left in its shipping carton and stored in a clean, dry area of the building or in a warehouse. Units must be stored in an upright position at all times. If carton stacking is necessary, stack units a maximum of 3 high. Do not remove any equipment from its shipping package until it is needed for installation.

PROTECTION — Once the units are properly positioned on the jobsite, cover them with either a shipping carton, vinyl film,

or an equivalent protective covering. Cap open ends of pipes stored on the jobsite. This precaution is especially important in areas where painting, plastering, or spraying of fireproof material, etc. is not yet complete. Foreign material that accumulates within the units can prevent proper start-up and necessitate costly clean-up operations.

Before installing any of the system components, be sure to examine each pipe, fitting, and valve, and remove any dirt or foreign material found in or on these components.

⚠ CAUTION

DO NOT store or install units in corrosive environments or in locations subject to temperature or humidity extremes (e.g., attics, garages, rooftops, etc.). Corrosive conditions and high temperature or humidity can significantly reduce performance, reliability, and service life. Always move units in an upright position. Tilting units on their sides may cause equipment damage.

INSPECT UNIT — To prepare the unit for installation, complete the procedures listed below:

1. Compare the electrical data on the unit nameplate with ordering and shipping information to verify that the correct unit has been shipped.
2. Verify that the unit is the correct model for the entering water temperature of the job.

3. Do not remove the packaging until the unit is ready for installation.
4. Verify that the refrigerant tubing is free of kinks or dents, and that it does not touch other unit components.
5. Inspect all electrical connections. Be sure connections are clean and tight at the terminals.
6. Loosen compressor bolts until the compressor rides freely on springs. Remove shipping restraints.
7. Remove the four 1/4 in. shipping bolts from compressor support plate (two bolts on each side) to maximize vibration and sound alternation.

⚠ CAUTION

Failure to remove shipping brackets from spring-mounted compressors will cause excessive noise and could cause component failure due to added vibration.

8. Remove any blower support cardboard from inlet of the blower.
9. Locate and verify any accessory kit located in compressor section.
10. Remove any access panel screws that may be difficult to remove once unit is installed.

Table 1 — Physical Data — 50PCH,PCV Units

50PCH,PCV UNIT	006	009	012	015	018	024	030	036	042	048	060
COMPRESSOR (1 each)	Rotary					Scroll					
REFRIGERANT TYPE						R-410A					
Factory Charge (oz)	17	18.5	23	32	43	43	47	50	70	74	82
FAN MOTOR AND BLOWER											
Fan Motor Type/Speeds	PSC/3										
Fan Motor (hp)											
Blower Wheel Size (Dia x W) (in.)	1/25 5 x 5	1/10	1/10 6 x 5	1/6	1/6 8 x 7	1/4	3/4 9 x 7	1/2	3/4 9 x 8	3/4	1 10 x 10 11 x 10
COAX VOLUME (gal.)	0.123	0.143	0.167	0.286	0.450	0.286	0.323	0.323	0.890	0.738	0.939
WATER CONNECTION SIZE FPT (in.)	1/2					3/4				1	
HORIZONTAL											
Air Coil Dimensions (H x W)(in.)	10 x 15			16 x 22			20 x 25			20 x 35	
Standard Filter - (Qty)	(1) 10 x 18			(1) 16 x 25			(1) 18 x 25			(1) 20 x 24, (1) 20 x 14	
1 in. Throwaway											
Weight (lb)											
Operating	103	105	114	153	158	174	182	203	218	263	278
Packaged	113	115	124	158	163	179	187	209	224	270	285
Corner Weight (lb)*											
Left-Front	37	38	42	53	55	62	67	75	81	98	103
Right-Front	24	24	26	36	37	40	41	47	50	60	64
Left-Back	23	23	25	34	35	39	40	44	48	58	61
Right-Back	19	20	21	30	31	33	34	37	39	47	75
VERTICAL											
Air Coil Dimensions (H x W)(in.)	10 x 15			20 x 17.25			24 x 17.75			24 x 28.25	
Standard Filter - (Qty)	(1) 10 x 18			(1) 20 x 20			(1) 24 x 24			(1) 14 x 24, (1) 18 x 24	
1 in. Throwaway											
Weight (lb)											
Operating	103	105	114	153	158	189	197	203	218	263	278
Packaged	113	115	124	158	163	194	202	209	224	270	285

LEGEND

FPT — Female Pipe Thread
PSC — Permanent Split Capacitor

*Front is located at control box end.

NOTES:

1. All units have grommet compressor mountings, and 1/2-in. and 3/4-in. electrical knockouts.
2. Maximum water working pressure is 500 psig.

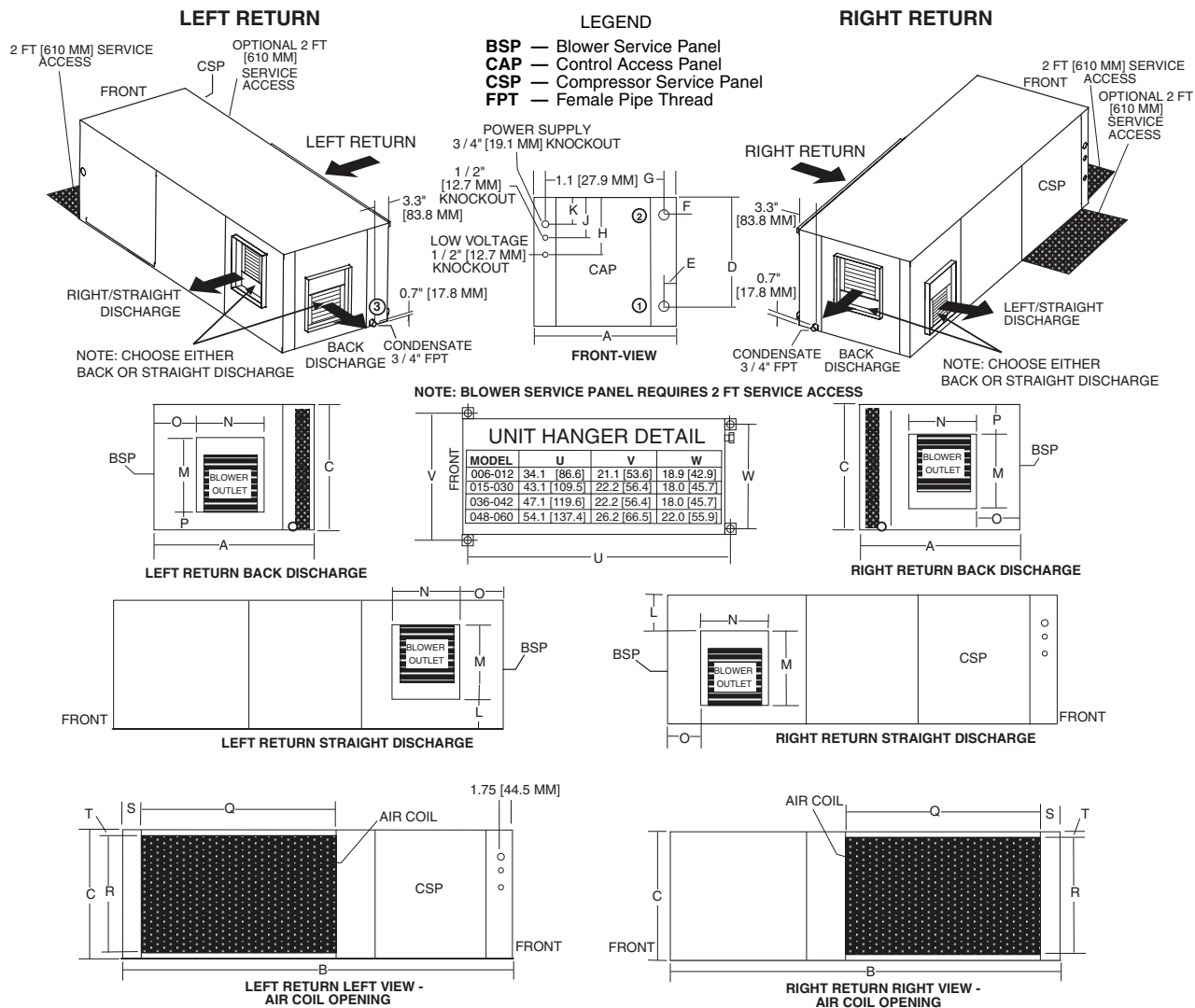

50PCH006-060 UNITS

50PCH UNIT SIZE	OVERALL CABINET			WATER CONNECTIONS				ELECTRICAL KNOCKOUTS			DISCHARGE CONNECTIONS DUCT FLANGE (± 0.10 in., ± 2.5 mm)				RETURN CONNECTION USING RETURN AIR OPENING					
	A Width	B Depth	C Height	1 Loop In		3 Loop Out		Size (IPT)	H 1/2-in. Low Voltage	J 1/2-in. Low Voltage	K 3/4-in. Power Supply	L	M Supply Height	N Supply Width	O	P	Q Return Depth	R Return Height	S	T
				D	E	F	G													
006-012	in. 19.1 cm 48.5	in. 34.1 cm 86.6	in. 11.1 cm 28.2	in. 9.6 cm 24.3	in. 1.1 cm 2.7	in. 1.5 cm 3.8	in. 1.1 cm 2.7	1/2 1.3	8.1 20.6	5.1 13.0	2.1 5.4	0.8 1.9	8.9 22.7	6.7 17.0	8.2 13.3	1.3 3.3	16.1 41.0	9.8 25.0	1.1 2.7	1.0 1.5
015	in. 20.1 cm 51.1	in. 43.1 cm 109.5	in. 17.0 cm 43.2	in. 15.1 cm 38.4	in. 1.4 cm 3.4	in. 3.2 cm 8.1	in. 1.4 cm 3.5	1/2 1.3	12.1 30.8	9.1 23.2	6.1 15.6	2.6 6.6	13.3 33.8	9.9 25.1	4.1 10.5	1.3 3.3	23.0 58.4	15.0 38.1	1.1 2.8	1.0 2.5
018	in. 20.1 cm 51.1	in. 43.1 cm 109.5	in. 17.0 cm 43.2	in. 15.1 cm 38.4	in. 1.4 cm 3.4	in. 4.1 cm 10.4	in. 1.4 cm 3.5	1/2 1.3	12.1 30.8	9.1 23.2	6.1 15.6	2.6 6.6	13.3 33.8	9.9 25.1	4.1 10.5	1.3 3.3	23.0 58.4	15.0 38.1	1.1 2.8	1.0 2.5
024	in. 20.1 cm 51.1	in. 43.1 cm 109.5	in. 18.3 cm 46.5	in. 15.1 cm 38.4	in. 1.4 cm 3.4	in. 4.4 cm 11.3	in. 1.4 cm 3.5	3/4 1.9	12.1 30.8	9.1 23.2	6.1 15.6	2.6 6.6	13.3 33.8	9.9 25.1	4.1 10.5	1.3 3.3	23.0 58.4	16.3 41.4	1.1 2.8	1.0 2.5
030	in. 20.1 cm 51.1	in. 43.1 cm 109.5	in. 18.3 cm 46.5	in. 15.1 cm 38.4	in. 1.4 cm 3.4	in. 3.1 cm 7.8	in. 1.4 cm 3.5	3/4 1.9	12.1 30.8	9.1 23.2	6.1 15.6	2.6 6.6	13.3 33.8	9.9 25.1	4.1 10.5	1.3 3.3	23.0 58.4	16.3 41.4	1.1 2.8	1.0 2.5
036	in. 20.1 cm 51.1	in. 47.1 cm 119.6	in. 21.0 cm 53.3	in. 15.1 cm 38.4	in. 1.4 cm 3.4	in. 5.3 cm 13.4	in. 1.4 cm 3.5	3/4 1.9	16.1 41.0	13.1 33.3	10.1 25.7	2.5 6.3	16.1 40.9	11.0 27.9	3.0 7.7	2.5 6.4	25.9 65.8	19.0 48.3	1.1 2.8	1.0 2.5
042	in. 20.1 cm 51.1	in. 47.1 cm 119.6	in. 21.0 cm 53.3	in. 15.1 cm 38.4	in. 1.4 cm 3.4	in. 4.4 cm 11.3	in. 1.4 cm 3.5	3/4 1.9	16.1 41.0	13.1 33.3	10.1 25.7	2.5 6.3	16.1 40.9	11.0 27.9	3.0 7.7	2.5 6.4	25.9 65.8	19.0 48.3	1.1 2.8	1.0 2.5
048	in. 24.1 cm 61.2	in. 54.1 cm 137.4	in. 21.0 cm 53.3	in. 15.1 cm 38.4	in. 1.4 cm 3.4	in. 4.4 cm 11.1	in. 1.4 cm 3.5	1 2.5	16.1 41.0	13.1 33.3	10.1 25.7	3.7 9.5	16.1 41.0	13.7 34.8	4.1 10.3	1.3 3.2	35.9 91.2	19.0 48.3	1.1 2.8	1.0 2.5
060	in. 24.1 cm 61.2	in. 54.1 cm 137.4	in. 21.0 cm 53.3	in. 15.1 cm 38.4	in. 1.4 cm 3.4	in. 3.8 cm 9.7	in. 1.4 cm 3.5	1 2.5	16.1 41.0	13.1 33.3	10.1 25.7	1.7 4.4	18.1 46.0	13.7 34.8	4.1 10.3	1.3 3.2	35.9 91.2	19.0 48.3	1.1 2.8	1.0 2.5

NOTES:

- While clear access to all removable panels is not required, installer should take care to comply with all building codes and allow adequate clearance for future field service.
- Horizontal units shipped with filter bracket only. This bracket should be removed for return duct connection.
- Discharge flange and hanger brackets are factory installed.
- Condensate is 3/4-in. (19.1 mm) FPT copper.
- Blower service panel requires 2 ft (610 mm) service access.
- Blower service access is through back panel on left or right discharge units or through panel opposite air coil on back discharge units.

Fig. 1 — 50PCH Unit Dimensions

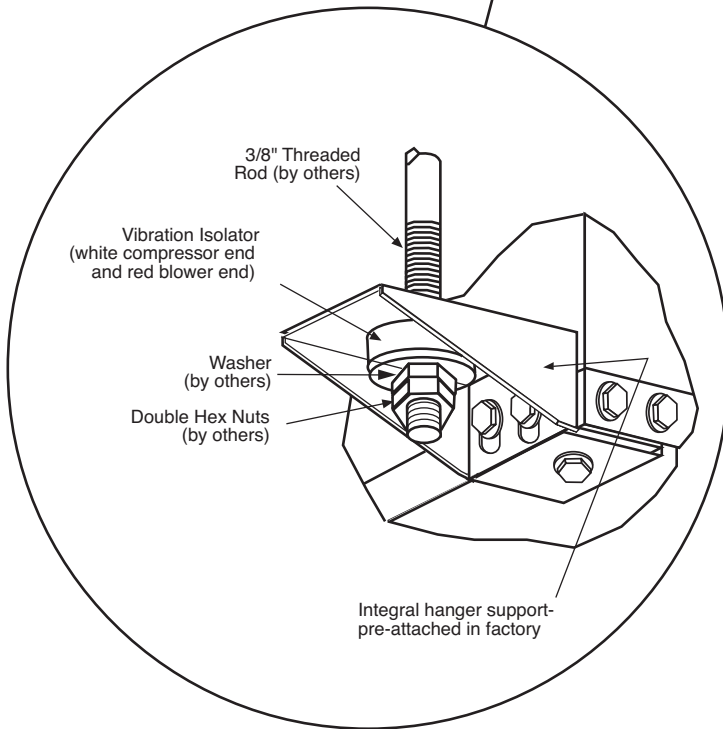
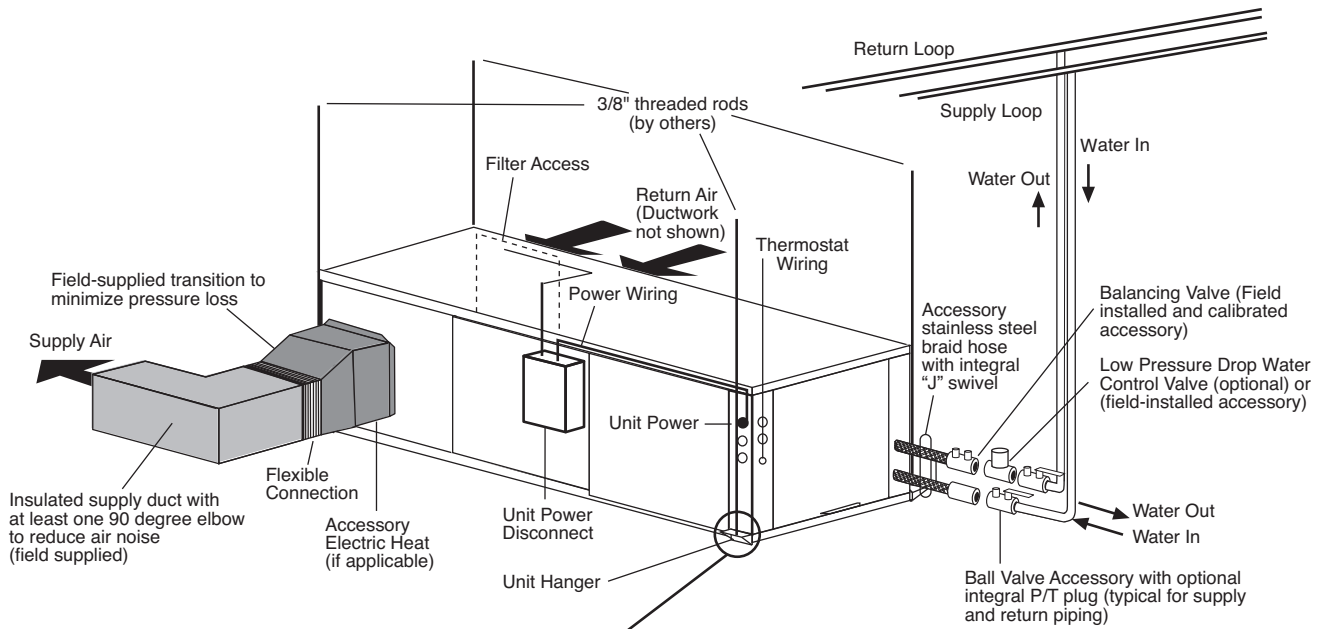

UNIT HANGER ISOLATION DETAIL

Fig. 2 — Typical Installation — 50PCH Units

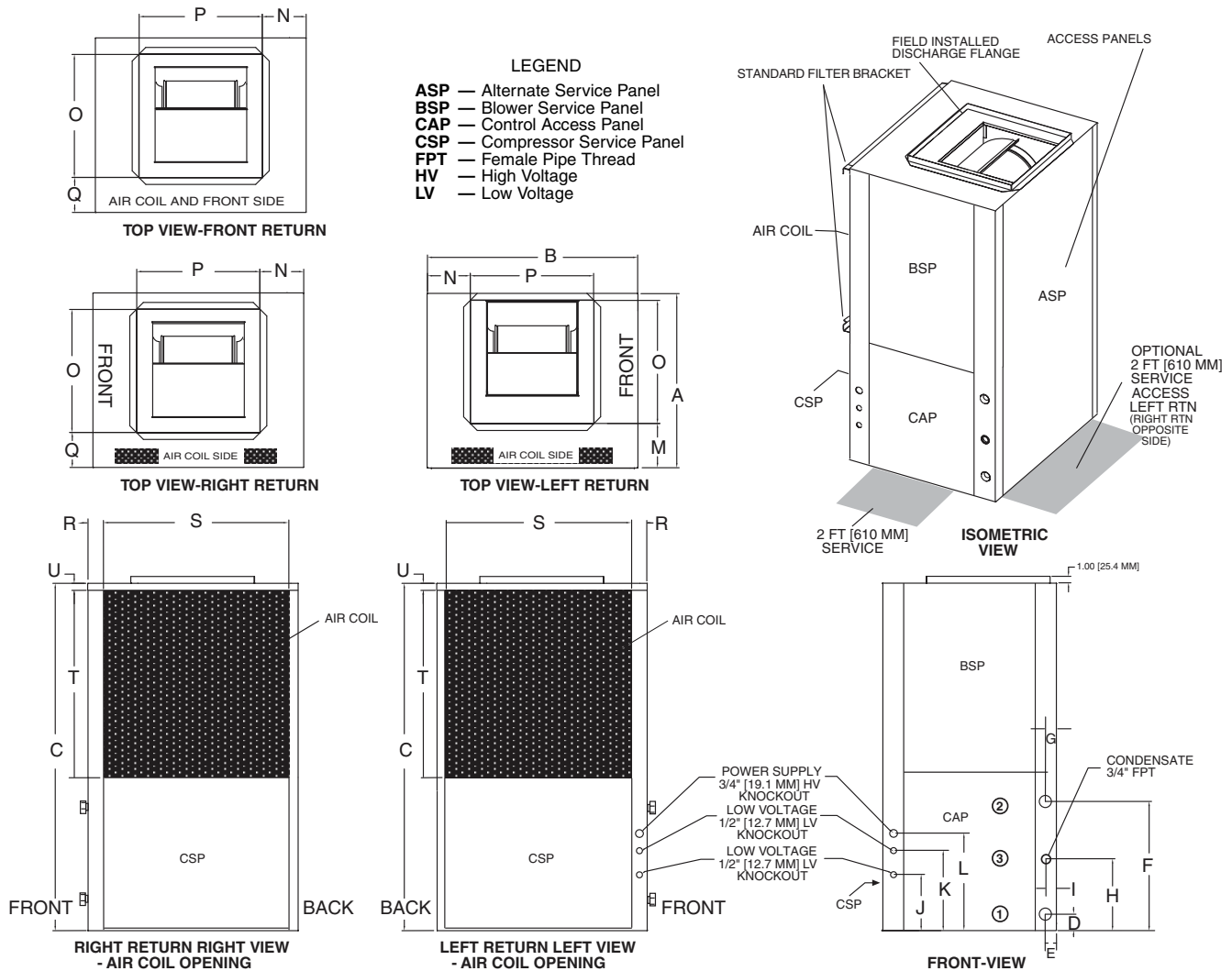

50PCV006-060 UNITS

50PCV UNIT SIZE	OVERALL CABINET			WATER CONNECTIONS						ELECTRICAL KNOCKOUTS			DISCHARGE CONNECTION DUCT FLANGE INSTALLED (±0.10 in., ±2.5 mm)					RETURN CONNECTION USING RETURN AIR OPENING				
	A Width	B Depth	C Height	1		2		3		Size (IPT)	J 1/2-in. (1.3 cm)	K 1/2-in. (1.3 cm)	L 3/4-in. (1.3 cm)	M	N	O Supply Width	P Supply Depth	Q	R	S Return Depth	T Return Height	U
				D	E	F	G	H	I		Low Voltage	Low Voltage	Power Supply									
	Loop In	Loop Out																				
006-012	in. 19.1 cm 48.5	in. 19.1 cm 48.5	in. 22.0 cm 55.9	1.4 3.6	1.6 4.1	9.5 24.1	1.6 4.3	6.1 15.6	1.6 4.1	1/2 1.3	2.9 7.3	5.9 14.9	8.9 22.5	8.9 22.7	5.1 12.9	9.0 22.9	9.0 22.9	5.5 14.0	2.1 5.3	16.2 41.1	9.9 25.1	0.7 1.9
015	in. 21.5 cm 54.6	in. 21.5 cm 54.6	in. 39.0 cm 99.1	1.9 4.8	1.4 3.6	13.8 35.1	1.4 3.6	8.1 20.6	1.4 3.6	1/2 1.3	4.1 10.5	7.1 18.1	10.1 25.7	6.4 16.1	3.8 9.5	14.0 35.6	14.0 35.6	5.3 13.6	2.3 5.8	18.3 46.5	20.9 53.1	0.7 1.9
018	in. 21.5 cm 54.6	in. 21.5 cm 54.6	in. 39.0 cm 99.1	1.9 4.8	1.4 3.6	12.9 32.8	1.4 3.6	8.1 20.6	1.4 3.6	1/2 1.3	4.1 10.5	7.1 18.1	10.1 25.7	6.4 16.1	3.8 9.5	14.0 35.6	14.0 35.6	5.3 13.6	2.3 5.8	18.3 46.5	20.9 53.1	0.7 1.9
024	in. 21.5 cm 54.6	in. 21.5 cm 54.6	in. 40.0 cm 101.6	1.9 4.8	1.4 3.6	13.8 35.1	1.4 3.6	8.1 20.6	1.4 3.6	3/4 1.9	4.1 10.5	7.1 18.1	10.1 25.7	6.4 16.1	3.8 9.5	14.0 35.6	14.0 35.6	5.3 13.6	2.3 5.8	18.3 46.5	20.9 53.1	0.7 1.9
030	in. 21.5 cm 54.6	in. 21.5 cm 54.6	in. 40.0 cm 101.6	1.9 4.8	1.4 3.6	15.2 38.6	1.4 3.6	8.1 20.6	1.4 3.6	3/4 1.9	4.1 10.5	7.1 18.1	10.1 25.7	6.4 16.1	3.8 9.5	14.0 35.6	14.0 35.6	5.3 13.6	2.3 5.8	18.3 46.5	20.9 53.1	0.7 1.9
036	in. 21.5 cm 54.6	in. 26.0 cm 66.0	in. 45.0 cm 114.3	1.9 4.8	1.4 3.6	15.7 39.9	1.4 3.6	8.1 20.6	1.4 3.6	3/4 1.9	4.1 10.5	7.1 18.1	10.1 25.7	6.4 16.1	3.8 9.5	14.0 35.6	14.0 35.6	5.1 13.1	2.3 5.8	22.8 57.9	23.9 60.7	0.7 1.9
042	in. 21.5 cm 54.6	in. 26.0 cm 66.0	in. 45.0 cm 114.3	1.9 4.8	1.4 3.6	16.6 42.0	1.4 3.6	8.1 20.6	1.4 3.6	3/4 1.9	4.1 10.5	7.1 18.1	10.1 25.7	6.4 16.1	3.8 9.5	14.0 35.6	14.0 35.6	5.1 13.1	2.3 5.8	22.8 57.9	23.9 60.7	0.7 1.9
048	in. 24.0 cm 61.0	in. 32.5 cm 82.6	in. 46.0 cm 116.8	1.9 4.8	1.4 3.6	16.6 42.2	1.4 3.6	8.1 20.6	1.4 3.6	1 2.5	4.1 10.5	7.1 18.1	10.1 25.7	6.9 17.4	7.3 18.4	16.0 40.6	18.0 45.7	5.1 13.1	2.3 5.8	29.3 74.4	22.5 57.0	0.7 1.9
060	in. 24.0 cm 61.0	in. 32.5 cm 82.6	in. 46.0 cm 116.8	1.9 4.8	1.4 3.6	16.7 42.4	1.4 3.6	8.1 20.6	1.4 3.6	1 2.5	4.1 10.5	7.1 18.1	10.1 25.7	6.9 17.4	7.3 18.4	16.0 40.6	18.0 45.7	5.1 13.1	2.3 5.8	29.3 74.4	22.5 57.0	0.7 1.9

- NOTES:
- Shaded areas are recommended service areas. Installer should take care to comply with all building codes and allow adequate clearance for future field service.
 - Front and side access is preferred for service access. However, all components may be serviced from the front access panel if side access is not available except on 50PCV009-030 with front return.
 - Discharge flange is field installed.
 - Condensate is 3/4 in. (19.1 mm) FPT.
 - Units shipped with filter rails. These rails should be removed for return duct connection. See WSHP Accessory Price Page for accessory air filter frame with duct collar.

Fig. 3 — 50PCV Unit Dimensions

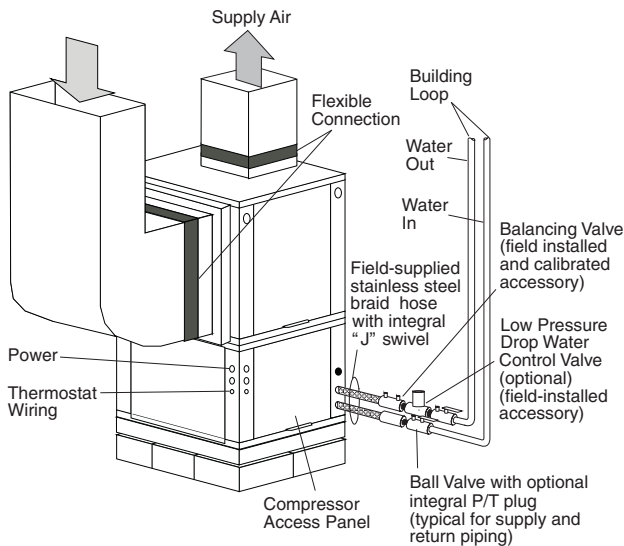

NOTE: Ball valve with integral pressure temperature plug recommended.

Fig. 4 — Typical Vertical Installation of 50PCV Unit

Step 3 — Locate Unit — The following guidelines should be considered when choosing a location for a WSHP:

- Units are for indoor use only.
- Locate in areas where ambient temperatures are between 40 F and 100 F and relative humidity is no greater than 75%.
- Provide sufficient space for water, electrical and duct connections.
- Locate unit in an area that allows easy access and removal of filter and access panels.
- Allow enough space for service personnel to perform maintenance.
- Return air must be able to freely enter the space if unit needs to be installed in a confined area such as a closet.
- Install the unit on a piece of rubber, neoprene or other mounting pad material for sound isolation. The pad should be at least $\frac{3}{8}$ in. [10 mm] to $\frac{1}{2}$ in. [13 mm] in thickness. Extend the pad beyond all four edges of the unit.
- Provide adequate clearance for filter replacement and drain pan cleaning. Do not block filter access with piping, conduit or other materials. Refer to Fig. 1 and 3 for dimensional data.
- Provide access for fan and fan motor maintenance and for servicing the compressor and coils without removing the unit.
- Provide an unobstructed path to the unit within the closet or mechanical room. Space should be sufficient to allow removal of the unit, if necessary.
- In limited side access installations, pre-removal of the control box side mounting screws will allow control box removal for future servicing.
- Provide access to water valves and fittings and screwdriver access to the unit side panels, discharge collar and all electrical connections.

NOTE: Correct placement of the horizontal unit can play an important part in minimizing sound problems. Since ductwork is normally applied to these units, the unit can be placed so that the principal sound emission is outside the occupied space in sound-critical applications. A fire damper may be required by the local code if a fire wall is penetrated.

FIELD CONVERSION OF DISCHARGE AIR — The discharge air of the 50PCH horizontal units can be converted

between side and back discharge in the field. The conversion process is the same for right and left return configurations. See Fig. 5 and 6.

NOTE: It is not possible to convert return air between left or right return models in the field due to refrigerant piping changes.

Preparation — The unit should be on the ground in a well lit area for conversion. Hung units should be taken down to ground level before converting.

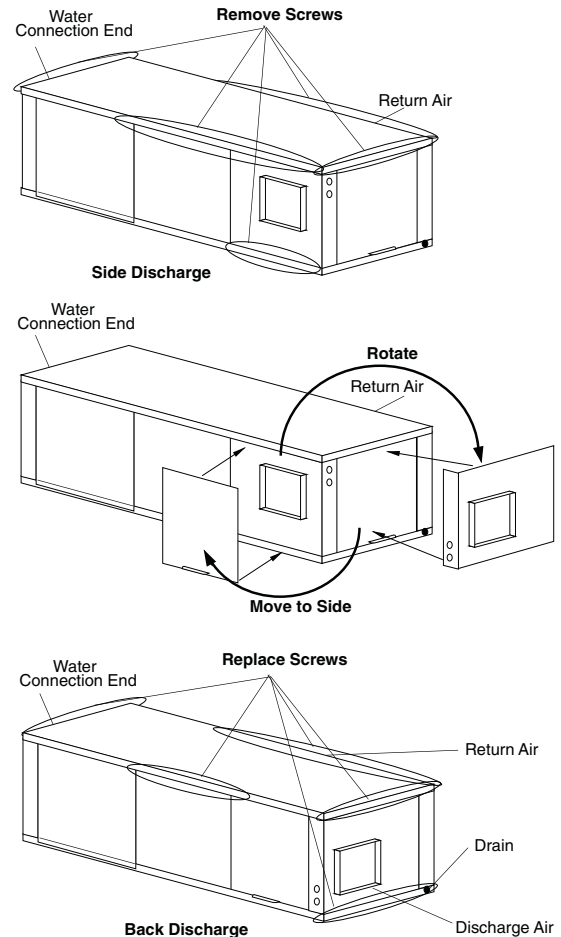

Fig. 5 — Conversion Left Return, Side Discharge to Back Discharge

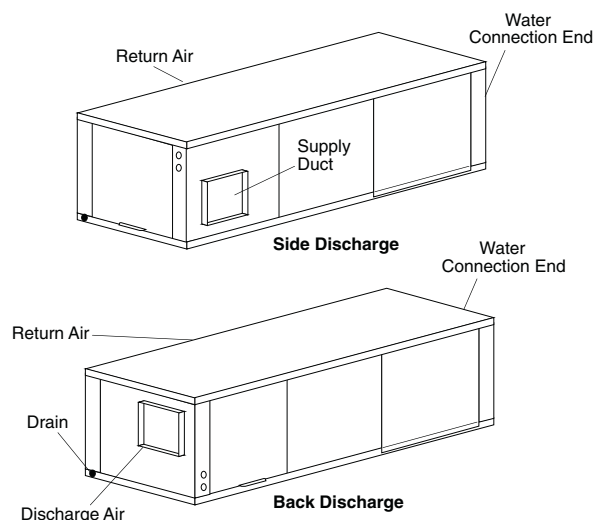

Fig. 6 — Conversion Right Return, Side Discharge to Back Discharge

Side to Back Discharge Conversion

1. Remove screws to free the top and discharge panels. See Fig. 5.
2. Remove the access panel and set aside.
3. Lift the discharge panel from side of unit and rotate it to back using care not to damage blower wiring.
4. Check blower wire routing and connections for undue tension or contact with sheet metal edges. Re-route if necessary.
5. Check refrigerant tubing for contact with other components. Adjust if necessary.
6. Reinstall top panel using screws set aside in Step 1.

NOTE: Location for some screws at bottom of discharge panel may have to be changed.

7. Manually spin fan wheel to check for obstructions. Adjust for any obstruction found.
8. Replace access panel.

Back to Side Discharge Conversion — Follow instructions above for Side to Back Discharge Conversion, noting the panels would be reversed.

Step 4 — Mount the Unit

HORIZONTAL UNITS (50PCH) — Horizontal units should be mounted using the factory-installed hangers. Proper attachment of hanging rods to building structure is critical for safety. See Fig. 2 and 7. Rod attachments must be able to support the weight of the unit. See Table 1 for unit operating weights.

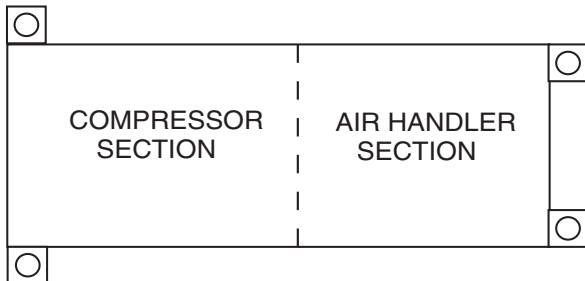

Fig. 7 — Horizontal Hanger Bracket (Factory Installed)

VERTICAL UNITS (50PCV) — Vertical units are available in left or right return air configurations. See Fig. 3. Mount the unit on a vibration absorption pad slightly larger than the entire base to minimize vibration transmission. It is not necessary to mount the unit on the floor. See Fig. 8.

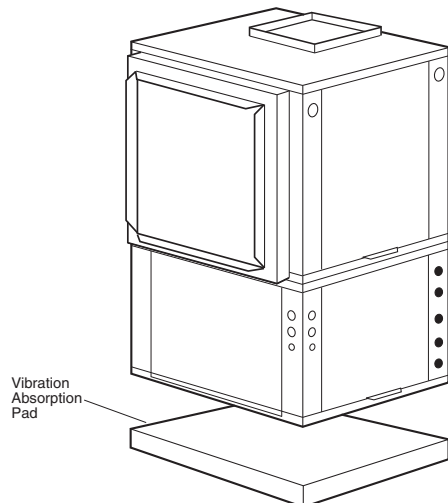

Fig. 8 — 50PCV Unit Mounted with Vibration Absorption Pad

NOTE: Some codes require the use of a secondary drain pan under vertical units. Check local codes for more information.

Step 5 — Check Duct System — Size the duct system to handle the design airflow quietly.

NOTE: Depending on the unit, the fan wheel may have a shipping support installed at the factory. This must be removed before operating unit.

SOUND ATTENUATION — To eliminate the transfer of vibration to the duct system, a flexible connector is recommended for both discharge and return air duct connections on metal duct systems. The supply and return plenums should include internal duct liner of fiberglass or be made of duct board construction to maximize sound attenuation of the blower. Installing the WSHP unit to uninsulated ductwork in an unconditioned space is not recommended since it will sweat and adversely affect the unit's performance.

To reduce air noise, at least one 90-degree elbow could be included in the supply and return air ducts, provided system performance is not adversely impacted. The blower speed can also be changed in the field to reduce air noise or excessive airflow, provided system performance is not adversely impacted.

EXISTING DUCT SYSTEM — If the unit is connected to existing ductwork, consider the following:

- Verify that the existing ducts have the proper capacity to handle the unit airflow. If the ductwork is too small, install larger ductwork.
- Check existing ductwork for leaks and repair as necessary.

NOTE: Local codes may require ventilation air to enter the space for proper indoor air quality. Hard-duct ventilation may be required for the ventilating air supply. If hard ducted ventilation is not required, be sure that a proper air path is provided for ventilation air to unit to meet ventilation requirement of the space.

Step 6 — Install Condensate Drain

HORIZONTAL UNITS (50PCH) — Slope the unit toward the drain at a $\frac{1}{4}$ in. drop at drain end. See Fig. 9. If it is not possible to meet the required pitch, install a condensate pump at the unit to pump condensate to building drain.

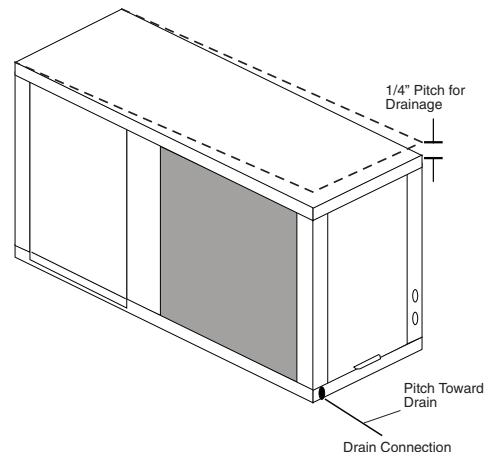
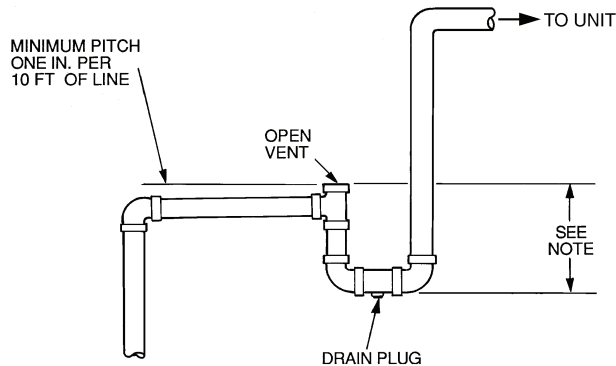

Fig. 9 — Horizontal Unit Pitch

Horizontal units are not internally trapped, therefore an external trap is necessary. Install each unit with its own individual trap and means to flush or blow out the condensate drain line. Do not install units with a common trap or vent. For typical condensate connections see Fig. 10.

NOTE: Never use a pipe size smaller than the connection.

VERTICAL UNITS (50PCV) — Each unit uses a condensate hose inside all cabinets as a trapping loop, therefore an external trap is not necessary and should not be used. See Fig. 11.



NOTE: Trap should be deep enough to offset maximum unit static difference. A 4-in. trap is recommended.

Fig. 10 — Trap Condensate Drain

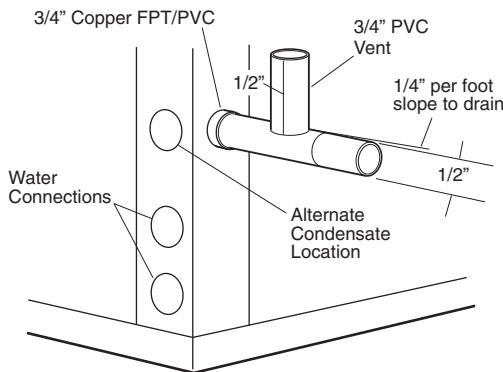

NOTE: Unit does not need to be sloped toward drain.

Fig. 11 — Vertical Condensate Connection

Each unit must be installed with its own individual vent and means to flush or blow out the condensate drain line. Do not install units with a common trap or vent.

VENTING — Install a vent in the condensate line of any application that may allow dirt or air to collect in the line. Consider the following:

- Always install a vent where an application requires a long horizontal run.
- Always install a vent where large units are working against higher external static pressure and to allow proper drainage for multiple units connected to the same condensate main.
- Be sure to support the line where anticipated sagging from the condensate or when “double trapping” may occur.
- If condensate pump is present on unit, be sure drain connections have a check valve to prevent back flow of condensate into other units.

Step 7 — Pipe Connections — Depending on the application, there are 3 types of WSHP piping systems to choose from: water loop, ground-water and ground loop. Refer to Piping Section of Carrier System Design Manual for additional information.

All WSHP units use low temperature soldered female pipe thread fittings for water connections to prevent annealing and out-of-round leak problems which are typically associated with high temperature brazed connections. Refer to Table 1 for connection sizes. When making piping connections, consider the following:

- Use a backup wrench when making screw connections to unit to prevent internal damage to piping.

- Insulation may be required on piping to avoid condensation in the case where fluid in loop piping operates at temperatures below dew point of adjacent air.
- Piping systems that contain steel pipes or fittings may be subject to galvanic corrosion. Dielectric fittings may be used to isolate the steel parts of the system to avoid galvanic corrosion.

WATER LOOP APPLICATIONS — Water loop applications usually include a number of units plumbed to a common piping system. Maintenance to any of these units can introduce air into the piping system. Therefore, air elimination equipment comprises a major portion of the mechanical room plumbing.

The flow rate is usually set between 2.25 and 3 gpm per ton of cooling capacity. For proper maintenance and servicing, pressure-temperature (P/T) ports are necessary for temperature and flow verification.

In addition to complying with any applicable codes, consider the following for system piping:

- Piping systems using water temperatures below 50 F require 1/2-in. closed cell insulation on all piping surfaces to eliminate condensation.
- Avoid all plastic to metal threaded fittings due to the potential to leak. Use a flange fitted substitute.
- Teflon tape thread sealant is recommended to minimize internal fouling of the heat exchanger.
- Use backup wrench. Do not overtighten connections.
- Route piping to avoid service access areas to unit.
- Flush the piping system prior to operation to remove dirt and foreign materials from the system.

GROUND-LOOP APPLICATIONS — Temperatures between 25 and 110 F and a cooling capacity of 2.25 to 3 gpm of flow per ton is recommended. In addition to complying with any applicable codes, consider the following for system piping:

- Limit piping materials to only polyethylene fusion in the buried sections of the loop.
- Do not use galvanized or steel fittings at any time due to corrosion.
- Avoid all plastic to metal threaded fittings due to the potential to leak. Use a flange fitted substitute.
- Do not overtighten connections.
- Route piping to avoid service access areas to unit.
- Use pressure-temperature (P/T) plugs to measure flow of pressure drop.

INSTALLATION OF SUPPLY AND RETURN HOSE KIT — Follow these piping guidelines.

1. Install a drain valve at the base of each supply and return riser to facilitate system flushing.
2. Install shutoff/balancing valves and unions at each unit to permit unit removal for servicing.
3. Place strainers at the inlet of each system circulating pump.
4. Select the proper hose length to allow slack between connection points. Hoses may vary in length by +2% to -4% under pressure.
5. Refer to Table 2. Do not exceed the minimum bend radius for the hose selected. Exceeding the minimum bend radius may cause the hose to collapse, which reduces water flow rate. Install an angle adapter to avoid sharp bends in the hose when the radius falls below the required minimum.

NOTE: Piping must comply with all applicable codes.

Table 2 — Metal Hose Minimum Bend Radii

HOSE DIAMETER (in.)	MINIMUM BEND RADII (in.)
1/2	2 1/2
3/4	4
1	5 1/2

Insulation is not required on loop water piping except where the piping runs through unheated areas or outside the building or when the loop water temperature is below the minimum expected dew point of the pipe ambient. Insulation is required if loop water temperature drops below the dew point.

IMPORTANT: Do not bend or kink supply lines or hoses.

Pipe joint compound is not necessary when Teflon* thread-ed tape is pre-applied to hose assemblies or when flared-end connections are used. If pipe joint compound is preferred, use compound only in small amounts on the male pipe threads of the fitting adapters. Prevent sealant from reaching the flared surfaces of the joint.

NOTE: When anti-freeze is used in the loop, assure that it is compatible with Teflon tape or pipe joint compound employed.

Maximum allowable torque for brass fittings is 30 ft-lb. If a torque wrench is not available, tighten finger-tight plus one quarter turn. Tighten steel fittings as necessary.

Optional pressure-rated hose assemblies designed specifically for use with Carrier units are available. Similar hoses can be obtained from alternate suppliers. Supply and return hoses are fitted with swivel-joint fittings at one end to prevent kinking during installation.

CAUTION

Backup wrench is required when tightening water connections to prevent water line damage. Failure to use a backup wrench could result in equipment damage.

Refer to Fig. 12 for an illustration of a supply/return hose kit. Male adapters secure hose assemblies to the unit and risers. Install hose assemblies properly and check them regularly to avoid system failure and reduced service life.

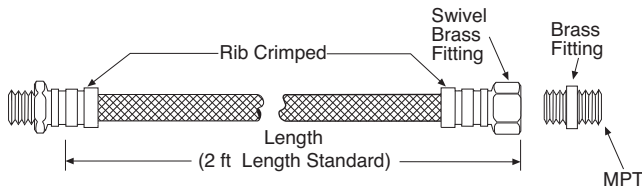

Fig. 12 — Supply/Return Hose Kit

Step 8 — Wire Field Power Supply

WARNING

To avoid possible injury or death due to electrical shock, open the power supply disconnect switch and secure it in an open position during installation.

CAUTION

Use only copper conductors for field-installed electrical wiring. Unit terminals are not designed to accept other types of conductors. Failure to follow this safety precaution could lead to equipment damage.

All field installed wiring, including the electrical ground, MUST comply with the National Electrical Code (NEC) as well as applicable local codes. In addition, all field wiring must conform to the Class II temperature limitations described in the NEC.

*Registered trademark of E. I. du Pont de Nemours and Company.

Refer to unit wiring diagrams Fig. 13-20 for a schematic of the field connections, which must be made by the installing (or electrical) contractor. Refer to Table 3 for fuse sizes.

Consult the unit wiring diagram located on the inside of the compressor access panel to ensure proper electrical hookup. The installing (or electrical) contractor must make the field connections when using field-supplied disconnect.

Operating voltage must be the same voltage and phase as shown in Table 3.

Make all final electrical connections with a length of flexible conduit to minimize vibration and sound transmission to the building.

POWER CONNECTION — Make line voltage connection by connecting the incoming line voltage wires to the L side of the CC terminal as shown in Fig. 21. See Table 3 for correct wire and maximum overcurrent protection sizing.

SUPPLY VOLTAGE — Operating voltage to unit must be within voltage range indicated on unit nameplate.

On 3-phase units, voltages under load between phases must be balanced within 2%. Use the following formula to determine the percentage voltage imbalance:

$$\% \text{ Voltage Imbalance} = 100 \times \frac{\text{max voltage deviation from average voltage}}{\text{average voltage}}$$

Example: Supply voltage is 460-3-60.

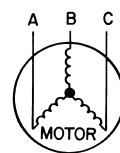

AB = 452 volts
BC = 464 volts
AC = 455 volts

$$\begin{aligned} \text{Average Voltage} &= \frac{452 + 464 + 455}{3} \\ &= \frac{1371}{3} \\ &= 457 \end{aligned}$$

Determine maximum deviation from average voltage:

(AB) $457 - 452 = 5 \text{ v}$
(BC) $464 - 457 = 7 \text{ v}$
(AC) $457 - 455 = 2 \text{ v}$

Maximum deviation is 7 v.

Determine percent voltage imbalance.

$$\begin{aligned} \% \text{ Voltage Imbalance} &= 100 \times \frac{7}{457} \\ &= 1.53\% \end{aligned}$$

This amount of phase imbalance is satisfactory as it is below the maximum allowable 2%.

Operation on improper line voltage or excessive phase imbalance constitutes abuse and may cause damage to electrical components.

NOTE: If more than 2% voltage imbalance is present, contact your local electric utility.

208-VOLT OPERATION — All 208-230 volt units are factory wired for 208 volts. The transformers may be switched to 230-volt operation by switching the red (208 volt) wire with the orange (230 volt) wire at the L1 terminal.

460-VOLT OPERATION — Units using 460-v and internal secondary pump will require a neutral wire from the supply side in order to feed accessory with 265-v.

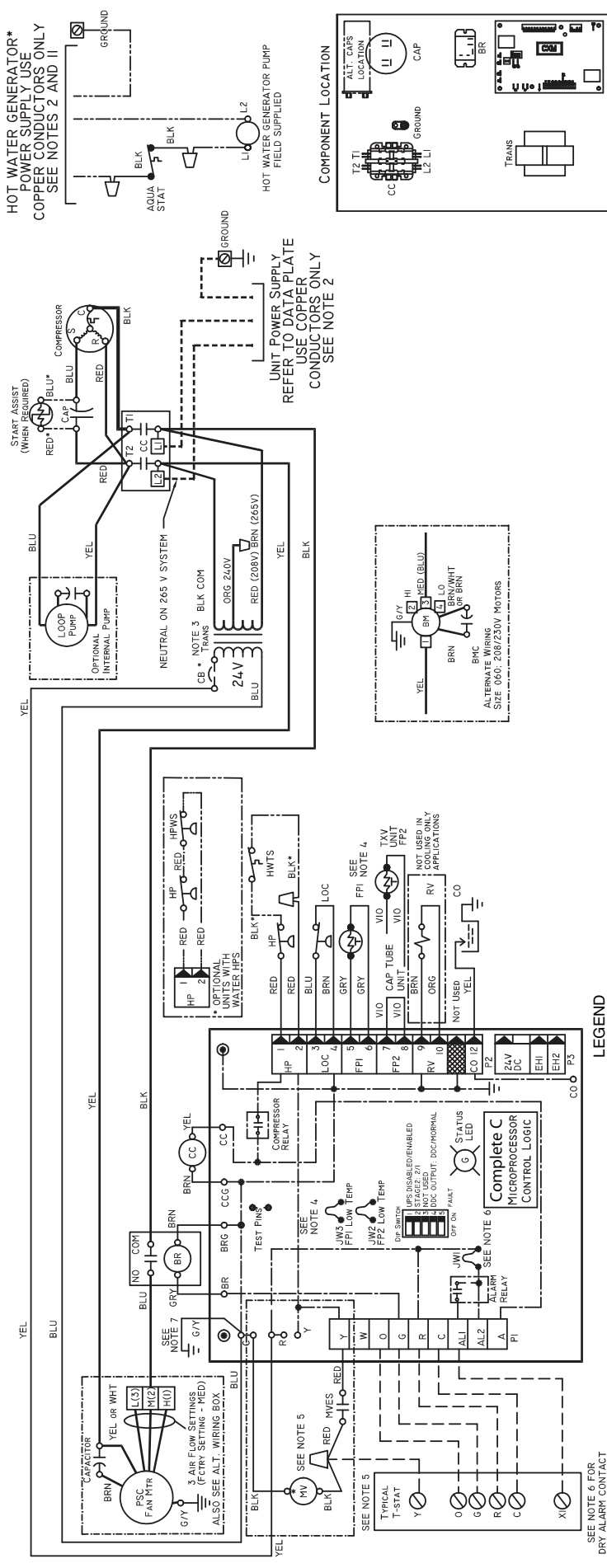

- LEGEND**
- AL Alarm Relay Contacts
 - BM Blower Motor
 - BMC Blower Motor Capacitor
 - BR Blower Relay
 - BRN Blower Relay
 - CAP Compressor Capacitor
 - CB Circuit Breaker
 - CC Compressor Contactor
 - CO Sensor, Condensate Overflow
 - FP1 Sensor, Low Temperature Protection Water Coil
 - FP2 Sensor, Low Temperature Protection Air Coil
 - HP High-Pressure Switch
 - HPWS High-Pressure Water Switch
 - HWTs High Leaving Water Temperature Switch
 - JW1 Jumper, Alarm
 - JW2 Jumper, Fan
 - JW3 Jumper, Fan
 - JW4 Jumper, Fan
 - JW5 Jumper, Fan
 - JW6 Jumper, Fan
 - JW7 Jumper, Fan
 - JW8 Jumper, Fan
 - JW9 Jumper, Fan
 - JW10 Jumper, Fan
 - JW11 Jumper, Fan
 - JW12 Jumper, Fan
 - JW13 Jumper, Fan
 - JW14 Jumper, Fan
 - JW15 Jumper, Fan
 - JW16 Jumper, Fan
 - JW17 Jumper, Fan
 - JW18 Jumper, Fan
 - JW19 Jumper, Fan
 - JW20 Jumper, Fan
 - JW21 Jumper, Fan
 - JW22 Jumper, Fan
 - JW23 Jumper, Fan
 - JW24 Jumper, Fan
 - JW25 Jumper, Fan
 - JW26 Jumper, Fan
 - JW27 Jumper, Fan
 - JW28 Jumper, Fan
 - JW29 Jumper, Fan
 - JW30 Jumper, Fan
 - JW31 Jumper, Fan
 - JW32 Jumper, Fan
 - JW33 Jumper, Fan
 - JW34 Jumper, Fan
 - JW35 Jumper, Fan
 - JW36 Jumper, Fan
 - JW37 Jumper, Fan
 - JW38 Jumper, Fan
 - JW39 Jumper, Fan
 - JW40 Jumper, Fan
 - JW41 Jumper, Fan
 - JW42 Jumper, Fan
 - JW43 Jumper, Fan
 - JW44 Jumper, Fan
 - JW45 Jumper, Fan
 - JW46 Jumper, Fan
 - JW47 Jumper, Fan
 - JW48 Jumper, Fan
 - JW49 Jumper, Fan
 - JW50 Jumper, Fan
 - JW51 Jumper, Fan
 - JW52 Jumper, Fan
 - JW53 Jumper, Fan
 - JW54 Jumper, Fan
 - JW55 Jumper, Fan
 - JW56 Jumper, Fan
 - JW57 Jumper, Fan
 - JW58 Jumper, Fan
 - JW59 Jumper, Fan
 - JW60 Jumper, Fan
 - JW61 Jumper, Fan
 - JW62 Jumper, Fan
 - JW63 Jumper, Fan
 - JW64 Jumper, Fan
 - JW65 Jumper, Fan
 - JW66 Jumper, Fan
 - JW67 Jumper, Fan
 - JW68 Jumper, Fan
 - JW69 Jumper, Fan
 - JW70 Jumper, Fan
 - JW71 Jumper, Fan
 - JW72 Jumper, Fan
 - JW73 Jumper, Fan
 - JW74 Jumper, Fan
 - JW75 Jumper, Fan
 - JW76 Jumper, Fan
 - JW77 Jumper, Fan
 - JW78 Jumper, Fan
 - JW79 Jumper, Fan
 - JW80 Jumper, Fan
 - JW81 Jumper, Fan
 - JW82 Jumper, Fan
 - JW83 Jumper, Fan
 - JW84 Jumper, Fan
 - JW85 Jumper, Fan
 - JW86 Jumper, Fan
 - JW87 Jumper, Fan
 - JW88 Jumper, Fan
 - JW89 Jumper, Fan
 - JW90 Jumper, Fan
 - JW91 Jumper, Fan
 - JW92 Jumper, Fan
 - JW93 Jumper, Fan
 - JW94 Jumper, Fan
 - JW95 Jumper, Fan
 - JW96 Jumper, Fan
 - JW97 Jumper, Fan
 - JW98 Jumper, Fan
 - JW99 Jumper, Fan
 - JW100 Jumper, Fan

- NOTES:**
- Compressor and blower motor thermally protected internally.
 - All wiring to the unit must comply with NEC and local codes.
 - Transformer for 208/230 v will be connected for 208 v operation. For 230 v operation, switch RED wire to ORG wire. Insulate open end of RED lead. Transformer is energy limiting or may have circuit breaker.
 - FP1 thermistor provides freeze protection for water. When using anti-freeze solutions, cut JW3 jumper.
 - Typical heat pump thermostat wiring shown. Refer to thermostat installation instructions for wiring to the unit. Wire "Y" from thermostat to "Y" Complete C when a motorized valve is not used. "O" terminal is not used in cooling only applications. Thermostat wiring must be Class 1 and voltage rating equal to or greater than unit supply voltage.
 - 24-v alarm signal shown. For dry alarm contact, cut JW1 jumper and for anti-freeze solutions, cut JW3 jumper.
 - Transformer secondary ground via green wire with yellow stripe from "C" terminal to control box.
 - Hot water generator pump only in models with hot water generation and internal pump option.
 - For auxiliary staging options, consult electric heat installation manual.
 - Fan motors factory wired for medium speed. For high or low speed, remove BLU wire from fan motor speed trap "M" and connect to "H" for high speed or "L" for low speed.
 - Aquastat is with unit and must be wired in series with the hot leg to the pump. Aquastat is rated for voltage up to 277 v.

Fig. 13 — 50PCH,PCV Units with Complete C Controller, Single-Phase

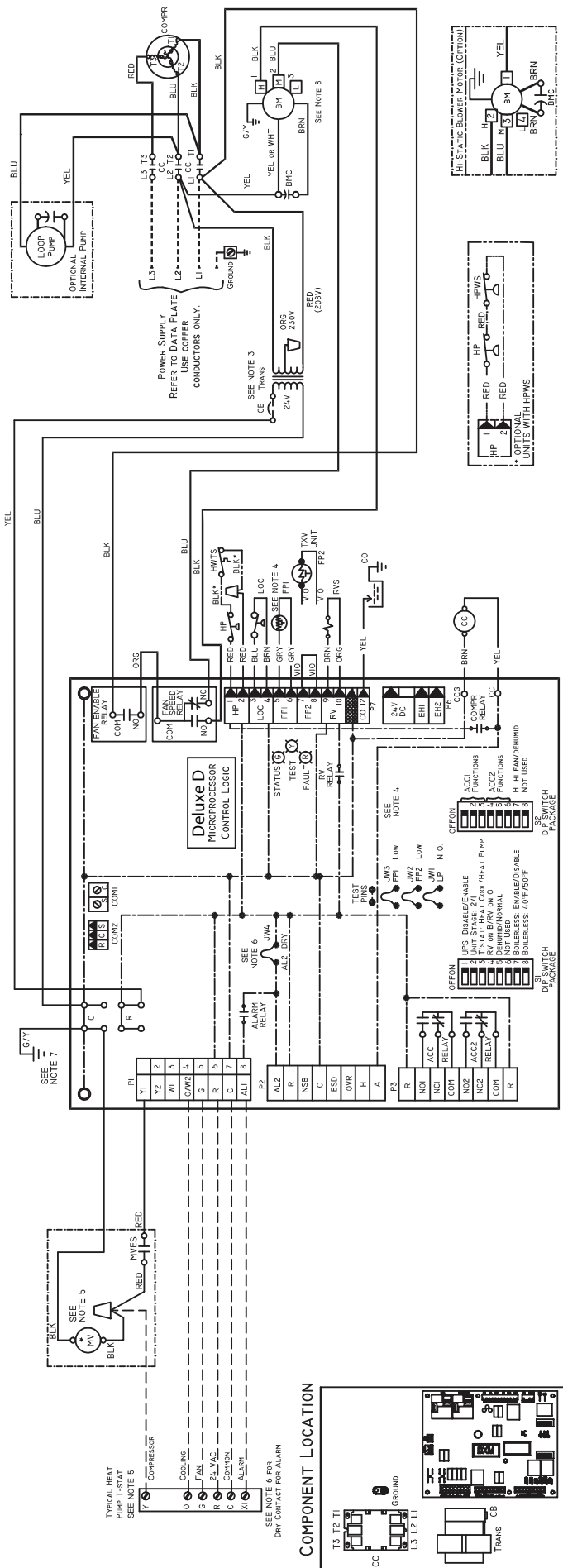

- LEGEND**
- LOC — Loss of Charge Pressure Switch
 - MV — Motorized Valve
 - MVES — Motorized Valve End Switch
 - NEC — National Electrical Code
 - P1 — Field Wiring Terminal Block
 - RVS — Reversing Valve Solenoid
 - TRANS — Transformer
 - TXV — Thermostatic Expansion Valve
 - — — — — Field Line Voltage Wiring
 - — — — — Field Low Voltage Wiring
 - · — · — Printed Circuit Trace
 - · · · — Optional Wiring
- AL — Alarm Relay Contacts
 - BM — Blower Motor
 - BMC — Blower Motor Capacitor
 - CB — Circuit Breaker
 - CC — Compressor Contactor
 - CO — Sensor, Condensate Overflow
 - FP1 — Sensor, Low Temperature Protection Water Coil
 - FP2 — Sensor, Low Temperature Protection Air Coil
 - HP — High-Pressure Switch
 - HPWS — High-Pressure Water Switch
 - HWTS — High Leaving Water Temperature Switch
 - JW1 — Jumper, Alarm

- NOTES:**
- Compressor thermally protected internally.
 - All wiring to the unit must comply with NEC and local codes.
 - Transformer is wired to 208-v RED lead for 208-3-60 units. For 230-3-60, switch RED and ORG leads at L1 and insulate RED lead. Transformer is energy limiting or may have circuit breaker.
 - FP1 thermistor provides freeze protection for water. When using anti-freeze solutions, cut JW3 jumper.
 - Refer to microprocessor control, LON, or thermostat installation instructions for wiring to the unit. Wire "Y" from thermostat to "Y1" Deluxe D terminal to control box.
 - Blower motor is factory wired for medium and high speeds. For any other combination of speeds, attach black wire to the higher of the two desired speed taps and the blue wire to the lower of the two desired speed taps.

Fig. 14 — 50PCH,PCV Units with Deluxe D Controller, Three-Phase (208/230 V)

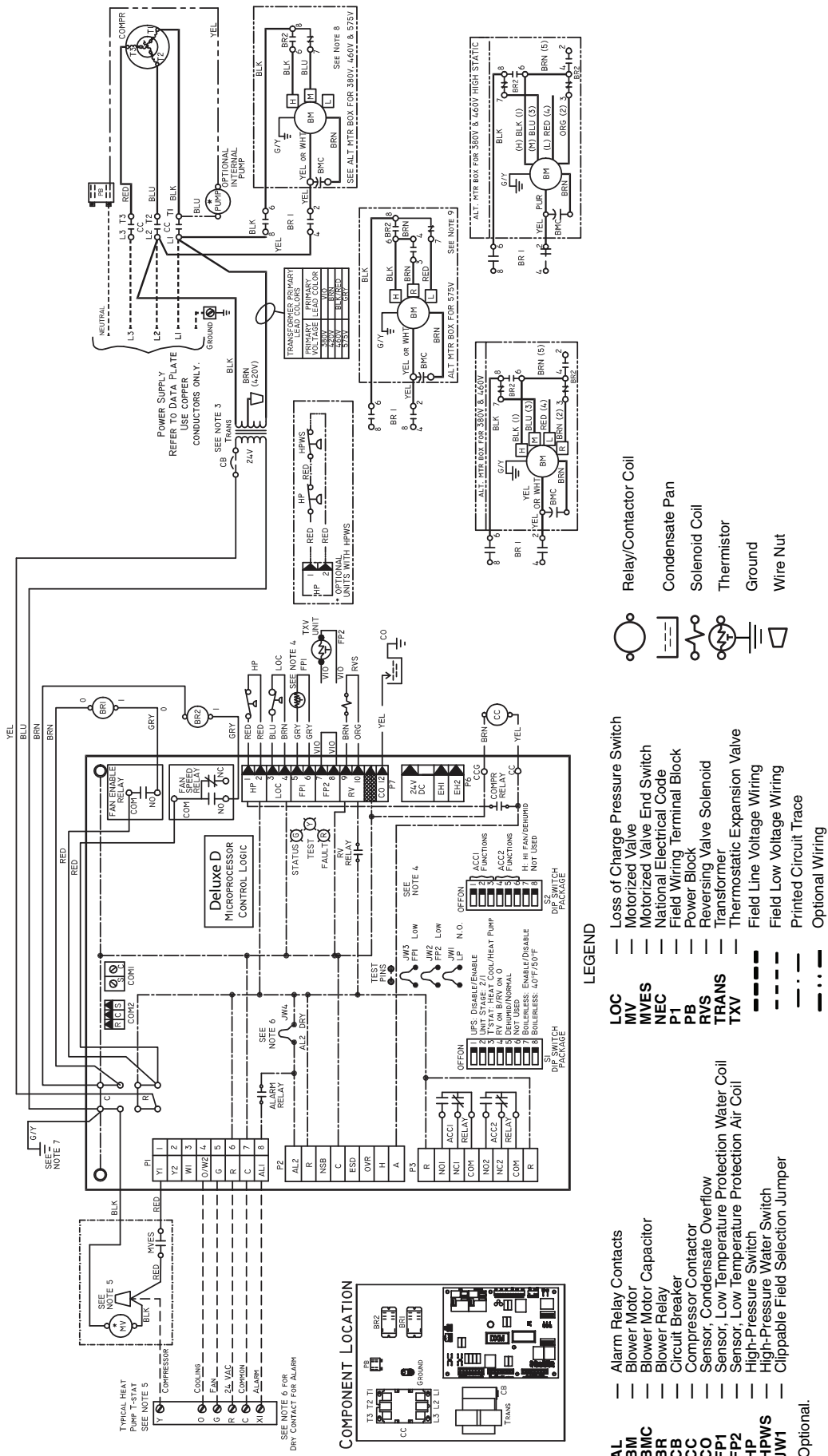
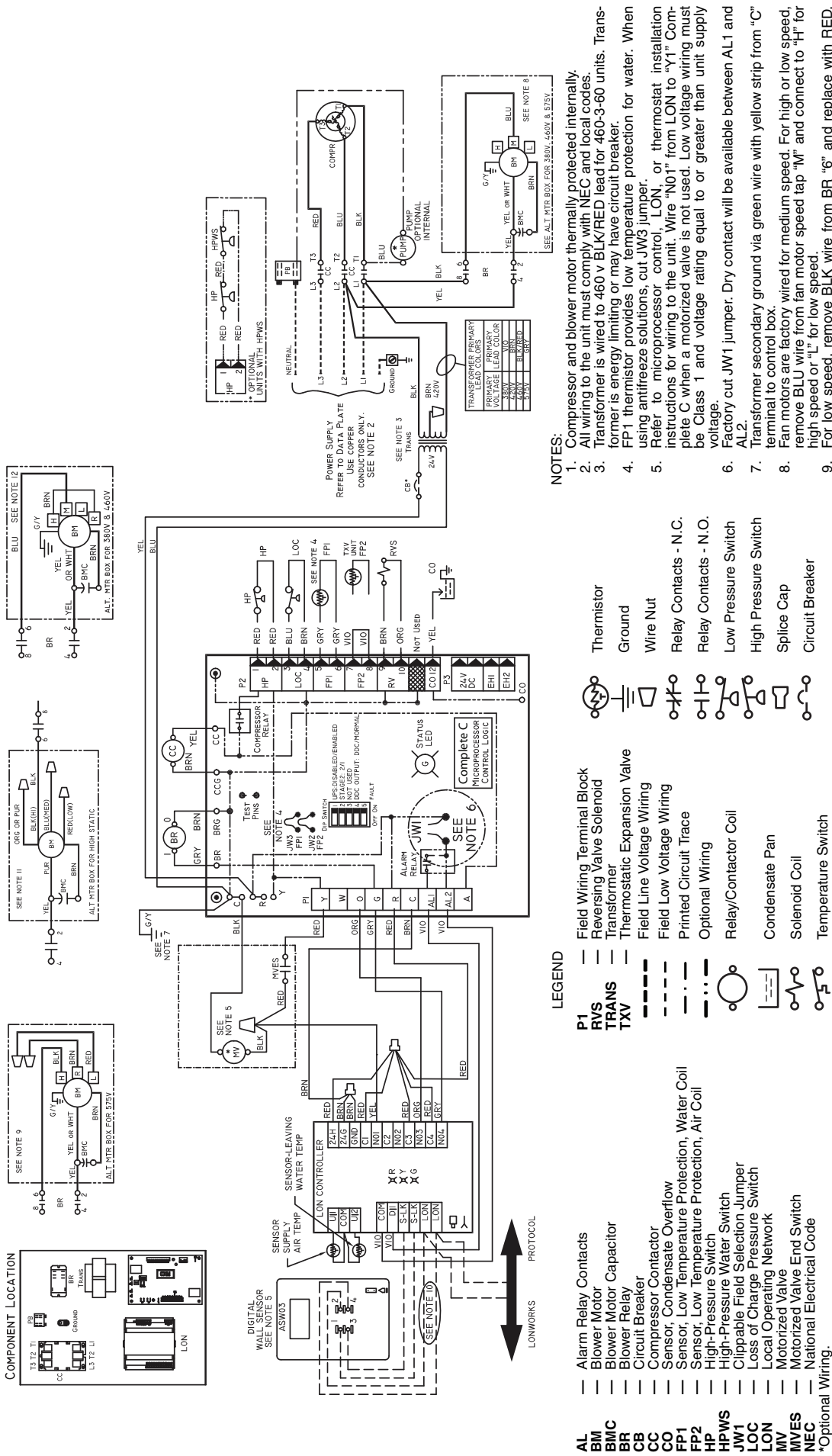

Fig. 15 — 50PCH,PCV Units with Deluxe D Controller, Three-Phase (460 V)



- COMPONENT LOCATION**
- DIGITAL WIRE (SEE NOTE 5)**
- LON CONTROLLER**
- LEGEND**
- Alarm Relay Contacts
 - Blower Motor
 - Blower Motor Capacitor
 - Blower Relay
 - Circuit Breaker
 - Sensor, Condensate Overflow
 - Sensor, Low Temperature Protection, Water Coil
 - Sensor, Low Temperature Protection, Air Coil
 - High-Pressure Switch
 - High-Pressure Water Switch
 - Clippable Field Selection Jumper
 - Loss of Charge Pressure Switch
 - Local Operating Network
 - Motorized Valve
 - Motorized Valve End Switch
 - National Electrical Code
 - Optional Wiring
- NOTES:**
1. Compressor and blower motor thermally protected internally.
 2. All wiring to the unit must comply with NEC and local codes.
 3. Transformer is wired to 460 v BLK/RED lead for 460-3-60 units. Transformer is energy limiting or may have circuit protection for water. When FP1 thermostat provides low temperature protection for water. When using antifreeze solutions, cut JW3 jumper.
 4. Refer to microprocessor control, LON, or thermostat installation instructions for wiring to the unit. Wire "N01" from LON to "Y1" Complete C when a motorized valve is not used. Low voltage wiring must be Class 1 and voltage rating equal to or greater than unit supply voltage.
 5. Factory cut JW1 jumper. Dry contact will be available between AL1 and AL2.
 6. Transformer secondary ground via green wire with yellow strip from "C" terminal to control box.
 7. Fan motors are factory wired for medium speed. For high or low speed, remove BLU wire from fan motor speed tap "M" and connect to "H" for high speed or "L" for low speed.
 8. For low speed, remove BLK wire from BR "6" and replace with RED. Connect LON and BRN wires together.
 9. Optional LON wires. Only connect if LON connection is desired at the wall sensor.
 10. For blower motors with leads. For medium or low speed, disconnect BLK wire from BR "6". Connect BLK and ORG/PUR wire together. Connect RED for low or BLU for medium to BR "6".
 11. Blower motor factory wired to medium speed. For low speed remove BLU wire from medium tap and connect to low speed tap. For high speed, remove BLU wire from existing speed tap and remove BRN jumper wire from high speed tap. Connect BLU wire to high speed tap. Tape off unconnected end of BRN jumper.
 12. The 460-v units using an internal secondary pump will require a neutral wire from the supply side in order to feed the accessory with 265-v.

Fig. 16 — 50PCH,PCV Units with Complete C and LON Controller (460 V)

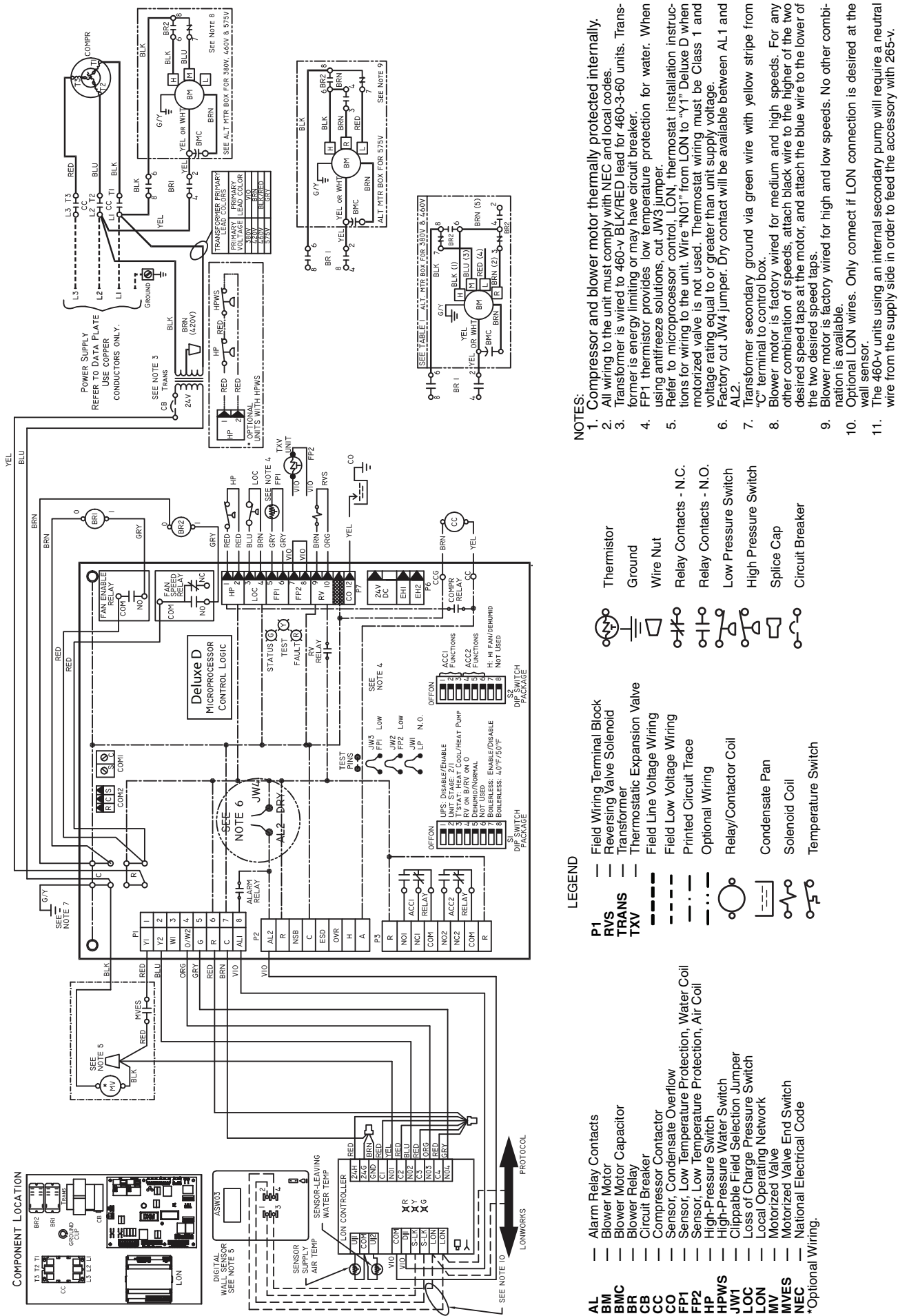

Fig. 17 — 50PCH, PCV units with Deluxe D and LON Controller (460 V)

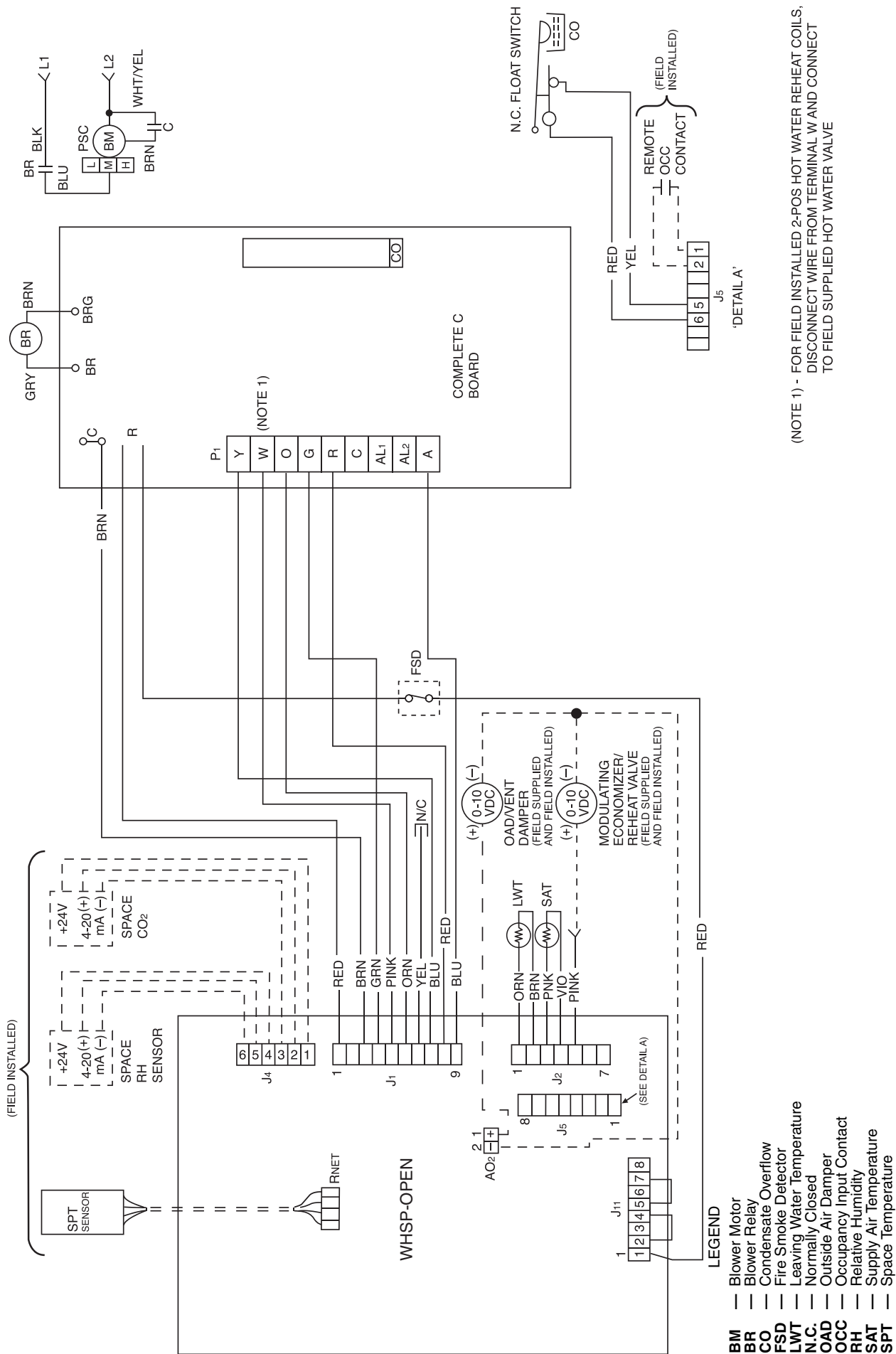

Fig. 18 — Units with Complete C and WSHP Open Multiple Protocol Controls

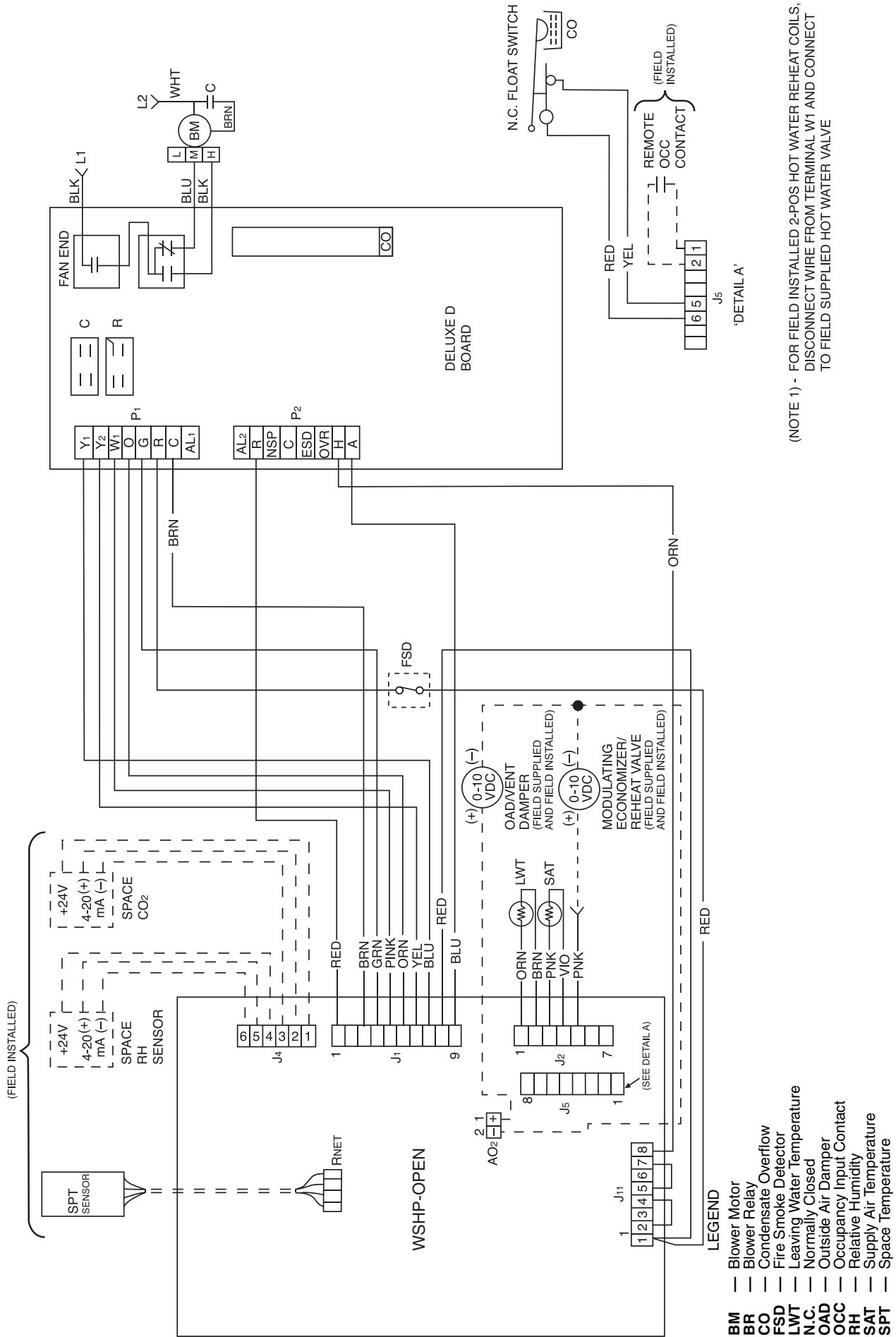
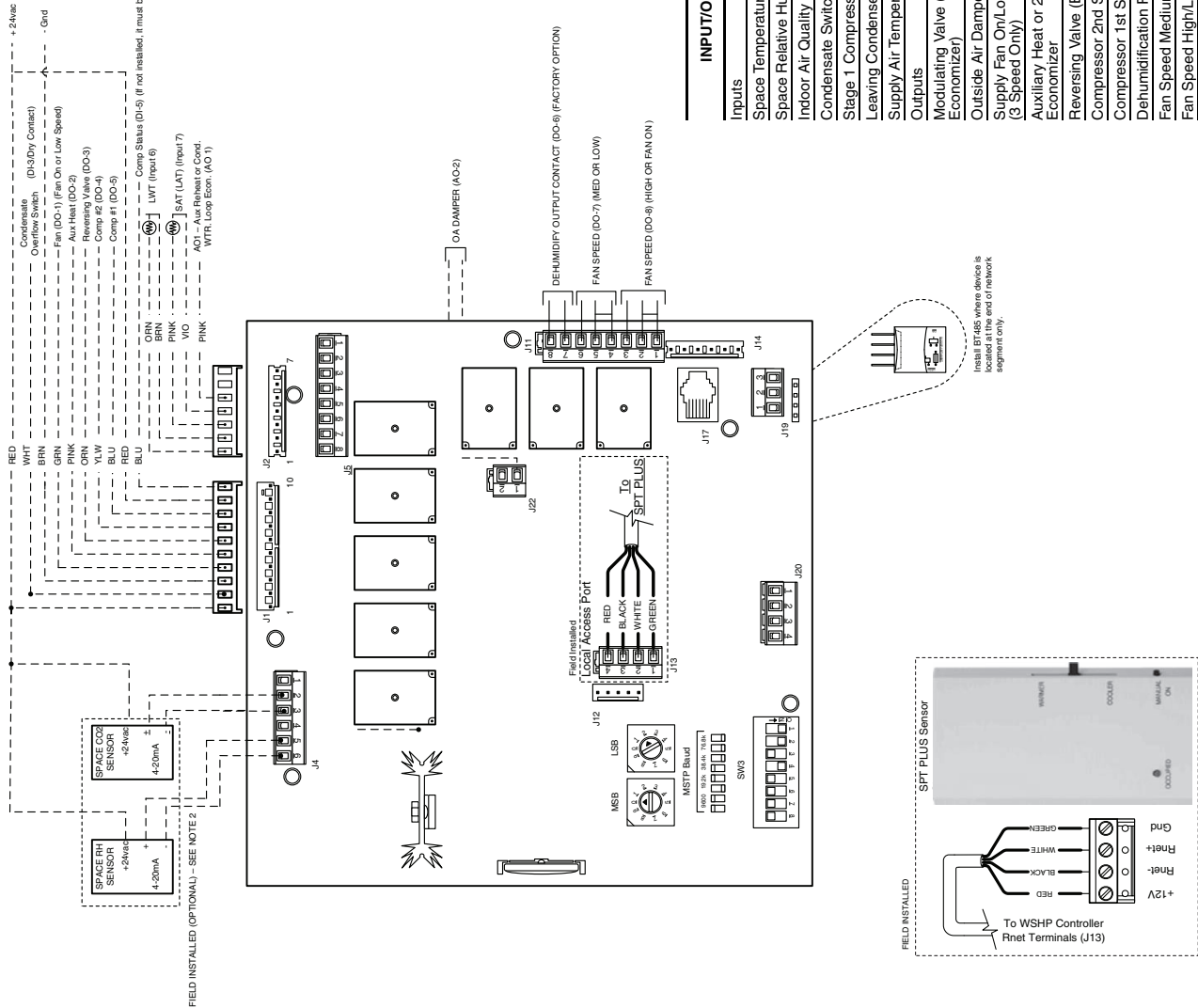

Fig. 19 — Units with Deluxe D and WSHP Open Multiple Protocol Controls



WSHP Open Inputs and Outputs Table

INPUT/OUTPUT TYPE	PART NUMBERS	TYPE OF I/O	CONNECTION PIN NUMBERS	CHANNEL DESIGNATION
Inputs				
Space Temperature Sensor	SPS, SPPL, SPP	Communicating	J13, 1 - 4	Local Access Port
Space Relative Humidity	33ZCSENSRH-01	AI (4 - 20mA)	J4, 5 and 6	Analog Input 1
Indoor Air Quality	33ZCSENCO2	AI (4 - 20mA)	J4, 2 and 3	Analog Input 2
Condensate Switch	N/A	BI (Dry Contacts)	J1, 2	Binary Input 3
Stage 1 Compressor Status	N/A	BI (Dry Contacts)	J1, 10	Binary Input 5
Leaving Condenser Water Temperature	10K Type II	AI (10K Thermistor)	J2, 1 and 2	Analog Input 6
Supply Air Temperature	33ZCSENSAT	AI (10K Thermistor)	J2, 3 and 4	Analog Input 7
Outputs				
Modulating Valve (Auxiliary Heat/Water Economizer)	N/A	AO (0-10Vdc/2 - 10Vdc)	J2 4 and 5*	Analog Output 1
Outside Air Damper	N/A	AO (0-10Vdc/2 - 10Vdc)	J22 1 and 2*	Analog Output 2
Supply Fan On/Low Speed (3 Speed Only)	N/A	BO Relay (24VAC, 1A)	J1, 4*	Binary Output 1 (G)
Auxiliary Heat or 2-Position Water Loop Economizer	N/A	BO Relay (24VAC, 1A)	J1, 5*	Binary Output 2
Reversing Valve (B or O Operation)	N/A	BO Relay (24VAC, 1A)	J1, 6*	Binary Output 3 (RV)
Compressor 2nd Stage	N/A	BO Relay (24VAC, 1A)	J1, 7	Binary Output 4 (Y2)
Compressor 1st Stage	N/A	BO Relay (24VAC, 1A)	J1, 8	Binary Output 5 (Y1)
Dehumidification Relay	N/A	BO Relay (24VAC, 1A)	J11, 7 and 8 (NO)	Binary Output 6
Fan Speed Medium/Low (3 Speed Only)	N/A	BO Relay (24VAC, 1A)	J11, 5 and 6 (NO)*	Binary Output 7
Fan Speed High/Low (3 Speed Only)	N/A	BO Relay (24VAC, 1A)	J11, 2 and 3 (NO)*	Binary Output 8

*These inputs are configurable.

Fig. 20 — WSHP Open Control

Table 3 — 50PCH,PCV Unit Electrical Data

50PCH,PCV UNIT	VOLTAGE CODE	RATED VOLTAGE V-Ph-Hz*	VOLTAGE MIN/MAX	COMPRESSOR			STANDARD UNITS				UNITS WITH HIGH-STATIC BLOWER			
				QTY	RLA	LRA	Fan Motor FLA	Total Unit FLA	Min Circuit AMP	Max Fuse/HACR	Fan Motor FLA	Total Unit FLA	Min Circuit AMP	Max Fuse/HACR
006	3	208/230-1-60	197/254	1	3.3	17.7	0.40	3.7	4.5	15	—	—	—	—
	4	265-1-60	239/292	1	2.9	13.5	0.40	3.3	4.0	15	—	—	—	—
009	3	208/230-1-60	197/254	1	5.6	22.2	0.80	6.4	7.8	15	—	—	—	—
	4	265-1-60	239/292	1	3.8	18.8	0.70	4.5	5.5	15	—	—	—	—
012	3	208/230-1-60	197/254	1	5.1	32.5	0.80	5.9	7.2	15	—	—	—	—
	4	265-1-60	239/292	1	4.0	31.5	0.70	4.7	5.7	15	—	—	—	—
015	3	208/230-1-60	197/254	1	6.0	29.0	1.00	7.0	8.5	15	1.00	7.0	8.5	15
	4	265-1-60	239/292	1	5.4	28.0	0.86	6.3	7.6	15	0.86	6.3	7.6	15
018	3	208/230-1-60	197/254	1	7.2	33.0	1.00	8.2	10.0	15	1.50	8.7	10.5	15
	4	265-1-60	239/292	1	5.9	28.0	0.86	6.8	8.2	15	1.30	7.2	8.7	15
024	3	208/230-1-60	197/254	1	12.8	58.3	1.50	14.3	17.5	30	3.00	15.8	19.0	30
	4	265-1-60	239/292	1	9.6	54.0	1.30	10.9	13.3	20	2.70	12.3	14.7	20
030	3	208/230-1-60	197/254	1	14.1	73.0	3.00	17.1	20.6	30	3.00	17.1	20.6	30
	4	265-1-60	239/292	1	11.2	60.0	2.70	13.9	16.7	25	2.70	13.9	16.7	25
	5	208/230-3-60	197/254	1	8.9	58.0	3.00	11.9	14.1	20	3.00	11.9	14.1	20
	6	460-3-60	414/506	1	4.2	28.0	1.70	5.9	7.0	15	1.70	5.9	7.0	15
036	3	208/230-1-60	197/254	1	16.7	79.0	1.80	18.5	22.7	35	3.00	19.7	23.9	40
	4	265-1-60	239/292	1	13.5	72.0	2.00	15.5	18.9	30	2.70	16.2	19.6	30
	5	208/230-3-60	197/254	1	10.4	73.0	1.80	12.2	14.8	25	3.00	13.4	16.0	25
042	6	460-3-60	414/506	1	5.8	38.0	1.24	7.0	8.5	15	1.70	7.5	9.0	15
	3	208/230-1-60	197/254	1	17.9	112.0	3.00	20.9	25.4	40	3.00	20.9	25.4	40
	5	208/230-3-60	197/254	1	13.5	88.0	3.00	16.5	19.9	30	3.00	16.5	19.9	30
	6	460-3-60	414/506	1	6.0	44.0	1.70	7.7	9.2	15	1.70	7.7	9.2	15
048	1	575-3-60	518/633	1	4.9	34.0	1.40	6.3	7.5	15	1.40	6.3	7.5	15
	3	208/230-1-60	197/254	1	21.8	117.0	3.40	25.2	30.7	50	4.90	26.7	32.2	50
	5	208/230-3-60	197/254	1	13.7	83.1	3.40	17.1	20.5	30	4.90	18.6	22.0	35
	6	460-3-60	414/506	1	6.2	41.0	1.80	8.0	9.6	15	2.50	8.7	10.3	15
060	1	575-3-60	518/633	1	4.8	33.0	1.40	6.2	7.4	15	1.90	6.7	7.9	15
	3	208/230-1-60	197/254	1	26.3	134.0	4.90	31.2	37.8	60	5.80	32.1	38.7	60
	5	208/230-3-60	197/254	1	15.6	110.0	4.90	20.5	24.4	40	5.80	21.4	25.3	40
	6	460-3-60	414/506	1	7.8	52.0	2.50	10.3	12.3	20	2.60	10.4	12.4	20
1	575-3-60	518/633	1	5.8	38.9	1.90	7.7	9.2	15	2.30	8.1	9.6	15	

LEGEND

- FLA — Full Load Amps
- HACR — Heating, Air Conditioning and Refrigeration
- LRA — Locked Rotor Amps
- RLA — Rated Load Amps

*Units using 460-v and ECM (electronically commutated motor), modulating HWR (hot water reheat), and/or internal secondary pump will require a neutral wire from the supply side in order to feed accessory with 265-v.

NOTES:

1. HACR circuit breaker in U.S.A. only.
2. All fuses
3. Class RK-5.

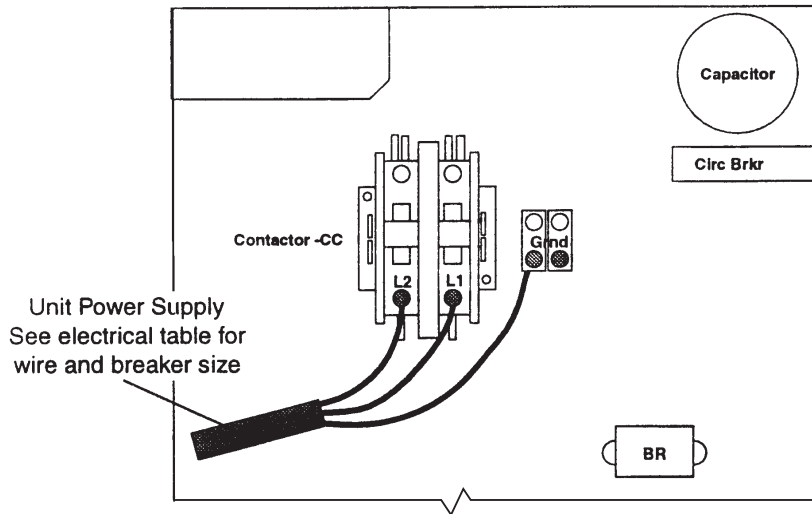
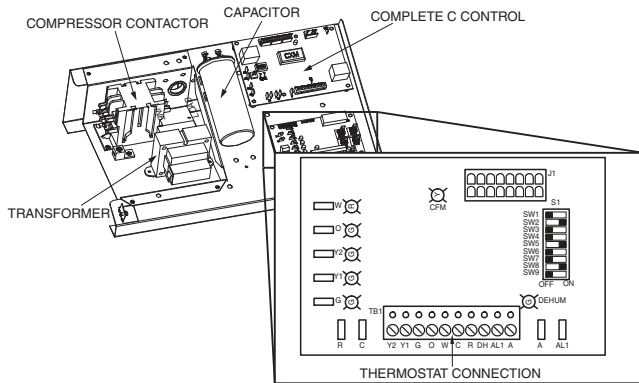

Fig. 21 — Typical Single-Phase Line Voltage Power Connection

Step 9 — Wire Field Controls

THERMOSTAT CONNECTIONS — The thermostat should be wired directly to the Aquazone™ control board. See Fig. 13-20, and 22.



NOTE: Low voltage connector may be removed for easy installation.

Fig. 22 — Low Voltage Field Wiring

WATER FREEZE PROTECTION — The Aquazone control allows the field selection of source fluid freeze protection points through jumpers. The factory setting of jumper JW3 (FP1) is set for water at 30 F. In earth loop applications, jumper JW3 should be clipped to change the setting to 10 F when using antifreeze in colder earth loop applications. See Fig. 23.

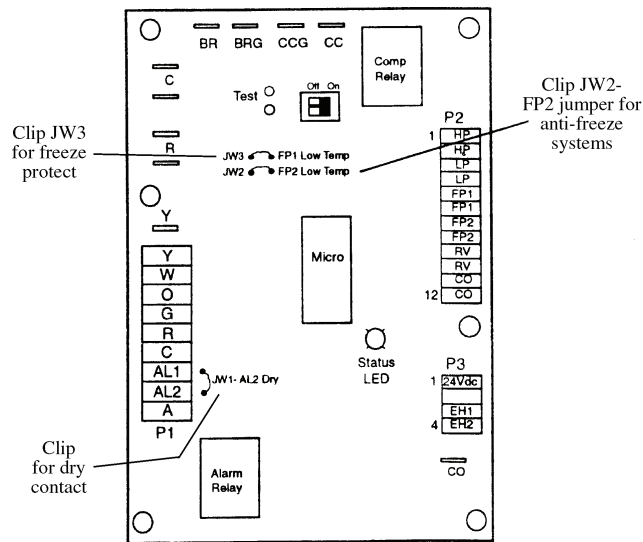

Fig. 23 — Typical Aquazone Control Board Jumper Locations (Complete C Control Shown)

AIR COIL FREEZE PROTECTION — The air coil freeze protection jumper JW2 (FP2) is factory set for 30 F and should not need adjusting.

ACCESSORY CONNECTIONS — Terminal A on the control is provided to control accessory devices such as water valves, electronic air cleaners, humidifiers, etc. This signal operates with the compressor terminal. See Fig. 24. Refer to the specific unit wiring schematic for details.

NOTE: The A terminal should *only* be used with 24 volt signals — not line voltage signals.

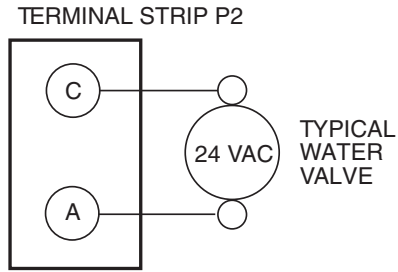

Fig. 24 — Typical Deluxe D Control Accessory Wiring

WATER SOLENOID VALVES — An external solenoid valve(s) should be used on ground water installations to shut off flow to the unit when the compressor is not operating. A slow closing valve may be required to help reduce water hammer. Figure 24 shows typical wiring for a 24-vac external solenoid valve. Figures 25 and 26 illustrate typical slow closing water control valve wiring for Taco 500 Series and Taco ESP Series valves. Slow closing valves take approximately 60 sec. to open (very little water will flow before 45 sec.). Once fully open, an end switch allows the compressor to be energized (only on valves with end switches). Only relay or triac based electronic thermostats should be used with slow closing valves. When wired as shown, the slow closing valve will operate properly with the following notations:

1. The valve will remain open during a unit lockout.
2. The valve will draw approximately 25 to 35 VA through the “Y” signal of the thermostat.

IMPORTANT: Connecting a water solenoid valve can overheat the anticipators of electromechanical thermostats. Only use relay based electronic thermostats.

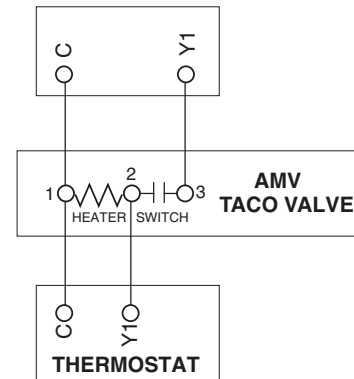

Fig. 25 — AMV Valve Wiring

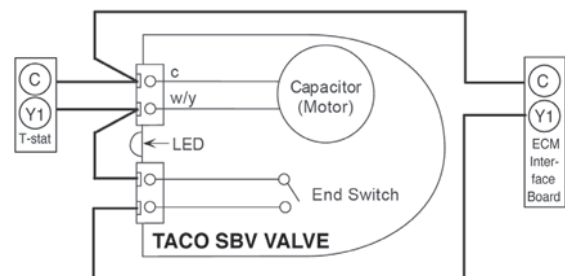

Fig. 26 — Taco SBV Valve Wiring

WSHP OPEN WIRING — The WSHP Open controller will be factory wired to the Complete C or Deluxe D control board, however, the system wiring will need to be completed utilizing WSHP Open controller wiring diagrams and the Third Party Integration (TPI) Guide. Factory installation includes harness, LWT (leaving water temperature), supply air, and condensate sensor.

⚠ WARNING

Disconnect all power to the unit before performing maintenance or service. Unit may automatically start if power is not disconnected. Failure to follow this warning could cause personal injury, death, and/or equipment damage.

Wiring Sensors to Inputs — Sensors can be wired to the WSHP Open controller's inputs. See Table 4.

All field control wiring that connects to the WSHP Open controller must be routed through the raceway built into the corner post. The raceway provides the UL required clearance between high and low-voltage wiring.

1. Pass control wires through the hole provided in the corner post.
2. Feed the wires through the raceway to the WSHP Open controller.
3. Connect the wires to the removable Phoenix connectors.
4. Reconnect the connectors to the board.

Field-Supplied Sensor Hardware — The WSHP Open controller is configurable with the following field-supplied sensors. See Table 4.

Table 4 — Field-Supplied Sensors for WSHP Open Controller

SENSOR	NOTES
Space Temperature Sensor (SPT)	Field Installed (Must be used with WSHP Open controller.)
Outdoor Air Temperature Sensor	Network Sensor
Indoor Air Quality Sensor (Separate Sensor)	Required only for demand control ventilation.
Space Relative Humidity Sensor	Separate Sensor

NOTE: BACview⁶ Handheld or Virtual BACview can be used as the user interface.

For specific details about sensors, refer to the literature supplied with the sensor.

Wiring a SPT Sensor — A WSHP Open controller is connected to a wall-mounted space temperature (SPT) sensor to monitor room temperature using a Molex plug.

The WSHP Open system offers the following SPT sensors. See Table 5.

Wire SPT sensors to the WSHP Open controller's Rnet port. An Rnetbus can consist of any of the following combinations of devices wired in a daisy-chain configuration:

- 1 SPT Plus, SPT Pro, or SPT Pro Plus sensors
- 1 to 4 SPT Standard sensors
- 1 to 4 SPT Standard sensors and 1 SPT Plus, SPT Pro, or SPT Pro Plus sensor
- Any of the above combinations, plus up to 2 BACview⁶ Handheld but no more than 6 total devices

NOTE: If the Rnetbus has multiple SPT Standard sensors, each sensor must be given a unique address on the Rnetbus. See the Carrier Open Sensor Installation Guide.

Use the specified type of wire and cable for maximum signal integrity. See Table 6.

Table 5 — SPT Sensors

SENSOR	PART NUMBER	FEATURES
SPT Standard	SPS	<ul style="list-style-type: none"> • Local access port • No operator control
SPT Plus	SPPL	<ul style="list-style-type: none"> • Slide potentiometer to adjust set point • Manual on button to override schedule • LED to show occupied status • Local access port
SPT Pro	SPP	<ul style="list-style-type: none"> • LCD display • Manual on button to override schedule • Warmer and cooler buttons to adjust set point • Info button to cycle through zone and outside air temperatures, set points, and local override time • Local access port
SPT Pro Plus	SPPF	<ul style="list-style-type: none"> • LCD display • Manual on button to override schedule • Warmer and cooler buttons to adjust set point • Info button to cycle through zone and outside air temperatures, set points, and local override time • Local access port • Fan speed*

*The SPT Pro Plus fan speed adjustment has no effect in this application.

Table 6 — Rnet Wiring Specifications

RNET WIRING SPECIFICATIONS	
Description	4 conductor, unshielded, CMP, plenum rated cable
Conductor	18 AWG
Maximum Length	500 ft
Recommended Coloring	Jacket: white Wiring: black, white, green, red
UL Temperature	32 to 167 F
Voltage	300-vac, power limited
Listing	UL: NEC CL2P, or better

LEGEND

- AWG — American Wire Gage
- CMP — Communications Plenum Cable
- NEC — National Electrical Code
- UL — Underwriters Laboratories

To wire the SPT sensor to the controller:

1. Partially cut, then bend and pull off the outer jacket of the Rnet cable(s), being careful not to nick inner insulation.
2. Strip about 1/4 in. of the inner insulation from each wire. See Fig. 27.

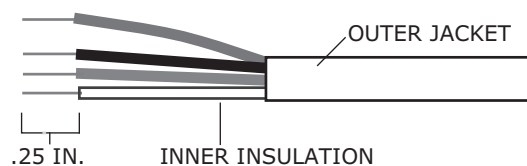

Fig. 27 — Rnet Cable Wire

3. Wire each terminal on the sensor to the same terminal on the controller. See Fig. 18-20. Table 7 shows the recommended Rnet wiring scheme.

Table 7 — Rnet Wiring

WIRE	TERMINAL
Red	+12-v
Black	.Rnet-
White	Rnet+
Green	Gnd

NOTE: The wire should be connected to the terminal shown.

Wiring a Supply Air Temperature (SAT) Sensor — The SAT sensor is required for reheat applications.

If the cable used to wire the SAT sensor to the controller will be less than 100 ft, an unshielded 22 AWG (American Wire Gage) cable should be used. If the cable will be greater than 100 ft, a shield 22 AWG cable should be used. The cable should have a maximum length of 500 ft.

To wire the SAT sensor to the controller:

1. Wire the sensor to the controller. See Fig. 18-20.
2. Verify that the Enable SAT jumper is on.
3. Verify that the Enable SAT and Remote jumper is in the left position.

Wiring an Indoor Air Quality (IAQ) Sensor — An IAQ sensor monitors CO₂ levels. The WSHP Open controller uses this information to adjust the outside-air dampers to provide proper ventilation. An IAQ sensor can be wall-mounted or mounted in a return air duct. (Duct installation requires an aspirator box assembly.)

The sensor has a range of 0 to 2000 ppm and a linear 4 to 20 mA output. This is converted to 1 to 5 vdc by a 250-ohm, 1/4 watt, 2% tolerance resistor connected across the zone controller's IAQ input terminals.

NOTE: Do not use a relative humidity sensor and CO₂ sensor on the same zone controller if both sensors are powered off the board. If sensors are externally powered, both sensors may be used on the same zone controller.

If the cable used to wire the IAQ sensor to the controller will be less than 100 ft, an unshielded 22 AWG (American Wire Gage) cable should be used. If the cable will be greater than 100 ft, a shield 22 AWG cable should be used. The cable should have a maximum length of 500 ft.

To wire the IAQ sensor to the controller:

1. Wire the sensor to the controller. See Fig. 18-20.
2. Install a field-supplied 250-ohm, 1/4 watt, 2% tolerance resistor across the controller's RH/IAQ and Gnd terminals.
3. Verify the the RH/IAQ jumper is set to 0 to 5-vdc.

Wiring a Relative Humidity (RH) Sensor — The RH sensor is used for zone humidity control (dehumidification) if the WSHP unit has a dehumidification device. If not, the sensor only monitors humidity.

NOTE: Do not use a relative humidity sensor and CO₂ sensor on the same zone controller if both sensors are powered off the board. If sensors are externally powered, both sensors may be used on the same zone controller.

If the cable used to wire the RH sensor to the controller will be less than 100 ft, an unshielded 22 AWG (American Wire Gage) cable should be used. If the cable will be greater than 100 ft, a shield 22 AWG cable should be used. The cable should have a maximum length of 500 ft.

To wire the RH sensor to the controller:

1. Strip the outer jacket from the cable for at least 4 inches.
2. Strip 1/4 in. of insulation from each wire.
3. Wire the sensor to the controller.

PRE-START-UP

System Checkout — When the installation is complete, follow the system checkout procedure outlined below before starting up the system. Be sure:

1. Voltage is within the utilization range specifications of the unit compressor and fan motor and voltage is balanced for 3 phase units.

2. Fuses, breakers and wire are correct size.
3. Low voltage wiring is complete.
4. Piping and system flushing is complete.
5. Air is purged from closed loop system.
6. System is balanced as required. Monitor if necessary.
7. Isolation valves are open.
8. Water control valves or loop pumps are wired.
9. Condensate line is open and correctly pitched.
10. Transformer switched to lower voltage tap if necessary.
11. Blower rotates freely — shipping support is removed.
12. Blower speed is on correct setting.
13. Air filter is clean and in position.
14. Service/access panels are in place.
15. Return-air temperature is between 40 to 80 F heating and 50 to 110 F cooling.
16. Air coil is clean.
17. Control field-selected settings are correct.

AIR COIL — To obtain maximum performance, clean the air coil before starting the unit. A ten percent solution of dishwasher detergent and water is recommended for both sides of the coil. Rinse thoroughly with water.

PSC (Permanent Split Capacitor) Blower Speed Selection —

The PSC blower fan speed can be changed by moving the blue wire on the fan motor terminal block to the desired speed as shown in Fig. 28. The 50PC units are designed to deliver rated airflow at nominal static (0.15 in. wg) on medium speed (factory setting) and rated airflow at a higher static (0.4 to 0.5 in. wg) on high speed for applications where higher static is required. Low speed will deliver approximately 85% of rated airflow at 0.10 in. wg. An optional 'high static' blower is available by using the special option code in the model nomenclature.

NOTE: Blower performance is shown in Tables 8-10.

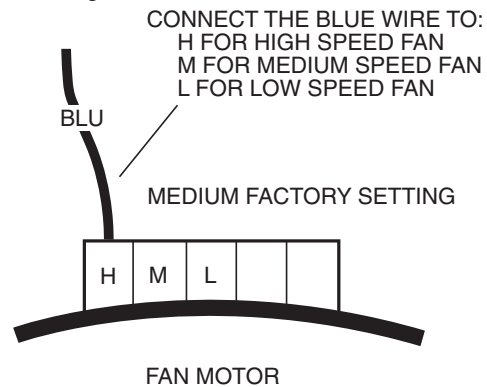

Fig. 28 — Blower Speed Selection

Table 8 — 50PCV Blower Performance with Wet Coil

COIL FACE VELOCITY (fpm)	WET COIL REDUCTION (in. wg)
200	0.030
250	0.055
300	0.080
350	0.100
400	0.120
450	0.140
500	0.160

Table 9 — 50PCH,PCV Blower Performance — Standard Unit

50PCH, PCV	FAN SPEED	RATED AIRFLOW	MIN CFM	AIRFLOW (cfm) AT EXTERNAL STATIC PRESSURE (in. wg)															
				0.00	0.05	0.10	0.15	0.20	0.25	0.30	0.35	0.40	0.45	0.50	0.60	0.70	0.80	0.90	1.00
006	Hi	220	150			310	300	290	280	270	250	230	210	180					
	Med					260	250	240	230	210	200	190	150						
009	Hi	325	225			410	400	380	360	350	330	320	300	280					
	Med					390	370	360	340	320	310	300	280	260					
012	Hi	400	300			470	460	450	440	430	420	400	390	380	320				
	Med					420	410	400	390	380	370	360	350	340					
015	Hi	525	375			745	725	706	696	686	666	637	588	539	451				
	Med					666	657	647	637	617	608	588	549	510					
018	Hi	600	450			745	725	706	696	686	666	637	588	539	451				
	Med					666	657	647	637	617	608	588	549	510					
024	Hi	800	600			941	931	912	893	874	855	836	817	789	732	732	656		
	Med					760	751	741	732	722	713	694	684	665	618	618	618	618	
030	Hi	1000	750			1140	1121	1093	1064	1102	1074	1045	1017	979	903	798			
	Med					998	979	960	931	912	884	855	827	751	751	751	751		
036	Hi	1200	900			1436	1416	1387	1358	1329	1310	1280	1232	1174	1077	931			
	Med					1106	1106	1096	1096	1086	1077	1067	1038	1009	912	912	912		
042	Hi	1350	1050			1501	1473	1444	1416	1378	1340	1302	1264	1226	1131				
	Med					1368	1349	1321	1302	1273	1245	1207	1169	1131	1064	1064	1064		
048	Hi	1600	1200			1805	1786	1881	1853	1815	1767	1710	1653	1596	1416	1216	1216		
	Med					1644	1625	1767	1729	1682	1653	1625	1577	1520	1340	1340	1340		
060	Hi	2000	1500			2185	2176	2156	2117	2078	2048	2019	1999	1970	1921	1842	1754	1627	
	Med					1999	1980	1950	1931	1901	1882	1852	1823	1793	1744	1676	1588	1588	1588

NOTES:

1. Shaded areas denote ESP (external static pressure) where operation is not recommended.
2. Units factory shipped on medium speed. Other speeds require field selection.
3. All airflow is rated and shown above at lowest voltage if unit is dual voltage rated, i.e., 208-v for 208/230-v units.
4. Only two-speed fan (Hi and Med) available on 575-v units.
5. Performance stated is at the rated power supply. Performance may vary as the power supply varies from the rated.

Table 10 — 50PCH,PCV Blower Performance — High-Static Unit

50PCH, PCV	FAN SPEED	RATED AIRFLOW	MIN CFM	AIRFLOW (cfm) AT EXTERNAL STATIC PRESSURE (in. wg)															
				0.00	0.05	0.10	0.15	0.20	0.25	0.30	0.35	0.40	0.45	0.50	0.60	0.70	0.80	0.90	1.00
015	Hi	525	375			774	764	755	745	735	715	696	676	637	519				
	Med					696	686	676	657	657	647	637	617	588	480				
018	Hi	600	450			774	764	755	745	735	715	696	676	637	519				
	Med					696	686	676	657	657	647	637	617	588	480				
024	Hi	800	600																
	Med							979	960	931	912	884	855	799	903	789	665		
030	Hi	1000	750																
	Med					998	988	979	960	941	931	912	893	865	836	798	988	874	760
036	Hi	1200	900																
	Med					1319	1310	1300	1290	1280	1271	1261	1242	1484	1455	1426	1358	1251	1135
042	Hi	1350	1050																
	Med					1321	1311	1302	1292	1473	1463	1444	1425	1397	1387	1378	1311	1178	
048	Hi	1600	1200																
	Med					1948	1948	1938	1919	1891	1872	1843	1824	1957	1938	1910	1862	1786	1701
060	Hi	2000	1500																
	Med					2352	2352	2342	2332	2323	2313	2293	2274	2254	225	2195	2156	2087	2019

NOTES:

1. Shaded areas denote ESP (external static pressure) where operation is not recommended.
2. Units factory shipped on medium speed. Other speeds require field selection.
3. All airflow is rated and shown above at lowest voltage if unit is dual voltage rated, i.e., 208-v for 208/230-v units.
4. Only two-speed fan (Hi and Med) available on 575-v units.
5. Performance stated is at the rated power supply. Performance may vary as the power supply varies from the rated.

FIELD SELECTABLE INPUTS

Jumpers and DIP (dual in-line package) switches on the control board are used to customize unit operation and can be configured in the field.

IMPORTANT: Jumpers and DIP switches should only be clipped when power to control board has been turned off.

Complete C Control Jumper Settings (Refer to Fig. 13 and 16)

WATER COIL FREEZE PROTECTION (FP1) LIMIT SETTING — Select jumper 3, (JW3-FP1 Low Temp) to choose FP1 limit of 10 F or 30 F. To select 30 F as the limit, DO NOT clip the jumper. To select 10 F as the limit, clip the jumper.

AIR COIL FREEZE PROTECTION (FP2) LIMIT SETTING — Select jumper 2 (JW2-FP2 Low Temp) to choose FP2 limit of 10 F or 30 F. To select 30 F as the limit, DO NOT clip the jumper. To select 10 F as the limit, clip the jumper.

ALARM RELAY SETTING — Select jumper 1 (JW1-AL2 Dry) for connecting alarm relay terminal (AL2) to 24 vac (R) or to remain as a dry contact (no connection). To connect AL2 to R, do not clip the jumper. To set as dry contact, clip the jumper.

Complete C Control DIP Switches — The Complete C control has 1 DIP switch block with two switches. Refer to Fig. 13 and 16.

PERFORMANCE MONITOR (PM) — DIP switch 1 will enable or disable this feature. To enable the PM, set the switch to ON. To disable the PM, set the switch to OFF.

STAGE 2 — DIP switch 2 will enable or disable compressor delay. Set DIP switch to OFF for stage 2 in which the compressor will have a 3-second delay before energizing.

NOTE: The alarm relay will not cycle during Test mode if switch is set to OFF, stage 2.

Deluxe D Control Jumper Settings (Refer to Fig. 14, 15, and 17)

WATER COIL FREEZE PROTECTION (FP1) LIMIT SETTING — Select jumper 3, (JW3-FP1 Low Temp) to choose FP1 limit of 10 F or 30 F. To select 30 F as the limit, DO NOT clip the jumper. To select 10 F as the limit, clip the jumper.

AIR COIL FREEZE PROTECTION (FP2) LIMIT SETTING — Select jumper 2 (JW2-FP2 Low Temp) to choose FP2 limit of 10 F or 30 F. To select 30 F as the limit, DO NOT clip the jumper. To select 10 F as the limit, clip the jumper.

ALARM RELAY SETTING — Select jumper 4 (JW4-AL2 Dry) for connecting alarm relay terminal (AL2) to 24 vac (R) or to remain as a dry contact (no connection). To connect AL2 to R, do not clip the jumper. To set as dry contact, clip the jumper.

LOW PRESSURE SETTING — The Deluxe D control can be configured for Low Pressure Setting (LP). Select jumper 1 (JW1-LP Norm Open) for choosing between low pressure input normally open or closed. To configure for normally closed operation, do not clip the jumper. To configure for normally open operation, clip the jumper.

Deluxe D Control DIP Switches — The Deluxe D control has 2 DIP switch blocks. Each DIP switch block has 8 switches and is labeled either S1 or S2 on the circuit board. Refer to Fig. 14, 15, and 17.

DIP SWITCH BLOCK 1 (S1) — This set of switches offers the following options for Deluxe D control configuration:

Performance Monitor (PM) — Set switch 1 to enable or disable performance monitor. To enable the PM, set the switch to ON. To disable the PM, set the switch to OFF.

Compressor Relay Staging Operation — Switch 2 will enable or disable compressor relay staging operation. The compressor relay can be set to turn on with stage 1 or stage 2 call from the thermostat. This setting is used with dual stage units (units with 2 compressors and 2 Deluxe D controls) or in master/slave applications. In master/slave applications, each compressor and fan will stage according to its switch 2 setting.

If switch is set to stage 2, the compressor will have a 3-second delay before energizing during stage 2 demand.

NOTE: If DIP switch is set for stage 2, the alarm relay will not cycle during Test mode.

Heating/Cooling Thermostat Type — Switch 3 provides selection of thermostat type. Heat pump or heat/cool thermostats can be selected. Select OFF for heat/cool thermostats. When in heat/cool mode, Y1 is used for cooling stage 1, Y2 is used for cooling stage 2, W1 is used for heating stage 1 and O/W2 is used for heating stage 2. Select ON for heat pump applications. In heat pump mode, Y1 used is for compressor stage 1, Y2 is used for compressor stage 2, W1 is used for heating stage 3 or emergency heat, and O/W2 is used for RV (heating or cooling) depending upon switch 4 setting.

O/B Thermostat Type — Switch 4 provides selection for heat pump O/B thermostats. O is cooling output. B is heating output. Select ON for heat pumps with O output. Select OFF for heat pumps with B output.

Dehumidification Fan Mode — Switch 5 provides selection of normal or dehumidification fan mode. Select OFF for dehumidification mode. The fan speed relay will remain OFF during cooling stage 2. Select ON for normal mode. The fan speed relay will turn on during cooling stage 2 in normal mode.

Switch 6 — Not used.

Boilerless Operation — Switch 7 provides selection of boilerless operation and works in conjunction with switch 8. In boilerless operation mode, only the compressor is used for heating when FP1 is above the boilerless changeover temperature set by switch 8 below. Select ON for normal operation or select OFF for boilerless operation.

Boilerless Changeover Temperature — Switch 8 on S1 provides selection of boilerless changeover temperature set point. Select OFF for set point of 50 F or ON for set point of 40 F.

If switch 8 is set for 50 F, then the compressor will be used for heating as long as the FP1 is above 50 F. The compressor will not be used for heating when the FP1 is below 50 F and the compressor will operate in emergency heat mode, staging on EH1 and EH2 to provide heat. If a thermal switch is being used instead of the FP1 thermistor, only the compressor will be used for heating mode when the FP1 terminals are closed. If the FP1 terminals are open, the compressor is not used and the control goes into emergency heat mode.

DIP SWITCH BLOCK 2 (S2) — This set of DIP switches is used to configure accessory relay options. Refer to Fig. 14, 15, and 17.

Switches 1 to 3 — These DIP switches provide selection of Accessory 1 relay options. See Table 11 for DIP switch combinations.

Switches 4 to 6 — These DIP switches provide selection of Accessory 2 relay options. See Table 12 for DIP switch combinations.

**Table 11 — DIP Switch Block S2 —
Accessory 1 Relay Options**

ACCESSORY 1 RELAY OPTIONS	DIP SWITCH POSITION		
	1	2	3
Cycle with Fan	On	On	On
Digital NSB	Off	On	On
Water Valve — Slow Opening	On	Off	On
OAD	On	On	Off

LEGEND

NSB — Night Setback
OAD — Outside Air Damper

NOTE: All other DIP switch combinations are invalid.

**Table 12 — DIP Switch Block S2 —
Accessory 2 Relay Options**

ACCESSORY 2 RELAY OPTIONS	DIP SWITCH POSITION		
	4	5	6
Cycle with Fan	On	On	On
Digital NSB	Off	On	On
Water Valve — Slow Opening	On	Off	On
OAD	On	On	Off

LEGEND

NSB — Night Setback
OAD — Outside Air Damper

NOTE: All other switch combinations are invalid.

Auto Dehumidification Mode or High Fan Mode — Switch 7 provides selection of auto dehumidification fan mode or high fan mode. In auto dehumidification fan mode the fan speed relay will remain off during cooling stage 2 if terminal H is active. In high fan mode, the fan enable and fan speed relays will turn on when terminal H is active. Set the switch to ON for auto dehumidification fan mode or to OFF for high fan mode.

Switch 8 — Not used.

Deluxe D Control Accessory Relay Configurations — The following accessory relay settings are applicable for both Deluxe D controls only:

CYCLE WITH FAN — In this configuration, the relay will be ON any time the Fan Enable relay is on.

CYCLE WITH COMPRESSOR — In this configuration, the relay will be ON any time the Compressor relay is on.

DIGITAL NIGHT SET BACK (NSB) — In this configuration, the relay will be ON if the NSB input is connected to ground C.

NOTE: If there are no relays configured for digital NSB, then the NSB and override (OVR) inputs are automatically configured for mechanical operation.

MECHANICAL NIGHT SET BACK — When NSB input is connected to ground C, all thermostat inputs are ignored. A thermostat set back heating call will then be connected to the OVR input. If OVR input becomes active, then the Deluxe D control will enter Night Low Limit (NLL) staged heating mode. The NLL staged heating mode will then provide heating during the NSB period.

Water Valve (Slow Opening) — If relay is configured for Water Valve (slow opening), the relay will start 60 seconds prior to starting compressor relay.

Outside Air Damper (OAD) — If relay is configured for OAD, the relay will normally be ON any time the Fan Enable relay is energized. The relay will not start for 30 minutes following a return to normal mode from NSB, when NSB is no longer connected to ground C. After 30 minutes, the relay will start if the Fan Enable is set to ON.

CAUTION

To avoid equipment damage, DO NOT leave system filled in a building without heat during the winter unless antifreeze is added to system water. Condenser coils never fully drain by themselves and will freeze unless winterized with antifreeze.

START-UP

Use the procedure outlined below to initiate proper unit start-up.

NOTE: This equipment is designed for indoor installation only.

Operating Limits

ENVIRONMENT — This equipment is designed for indoor installation ONLY. Extreme variations in temperature, humidity and corrosive water or air will adversely affect the unit performance, reliability and service life.

POWER SUPPLY — A voltage variation of $\pm 10\%$ of nameplate utilization voltage is acceptable.

UNIT STARTING CONDITIONS — Depending on the model, units start and operate in an ambient temperature of 45 F with entering-air temperature at 40 F or 50 F, entering-water temperature at 20 F or 50 F and with both air and water at the flow rates used.

NOTE: These operating limits are not normal or continuous operating conditions. Assume that such a start-up is for the purpose of bringing the building space up to occupancy temperature. See Table 14 for operating limits.

WARNING

When the disconnect switch is closed, high voltage is present in some areas of the electrical panel. Exercise caution when working with the energized equipment. Failure to heed this warning could lead to personal injury.

1. Restore power to system.
2. Turn thermostat fan position to ON. Blower should start.
3. Balance airflow at registers.
4. Adjust all valves to the full open position and turn on the line power to all heat pump units.
5. Operate unit in the cooling cycle first, then the heating cycle. Refer to Table 13 for unit operating limits. Allow 15 minutes between cooling and heating tests for pressure to equalize.

NOTE: Two factors determine the operating limits of a unit: entering-air temperature and water temperature. Whenever any of these factors are at a minimum or maximum level, the other two factors must be at a normal level to ensure proper unit operation. See Table 13.

Table 13 — Operating Limits — 50PCH,PCV Units

OPERATING LIMITS	COOLING (F)	HEATING (F)
AIR LIMITS		
Min. Ambient Air – db	45	39
Rated Ambient Air – db	80.6	68
Max. Ambient Air – db	110	85
Min. Entering Air – db/wb	50	40
Rated Entering Air – db/wb	80.6/66.2	68
Max. Entering Air – db/wb	110/83	80
WATER LIMITS		
Min. Entering Water	30	20
Normal Entering Water	50-110	30-70
Max. Entering Water	120	90
Normal Water Flow	2.5-3.0 gpm per ton	

LEGEND

db — Dry Bulb
wb — Wet Bulb

Scroll Compressor Rotation — It is important to be certain compressor is rotating in the proper direction. To determine whether or not compressor is rotating in the proper direction:

1. Connect service gages to suction and discharge pressure fittings.
2. Energize the compressor.
3. The suction pressure should drop and the discharge pressure should rise, as is normal on any start-up.

If the suction pressure does not drop and the discharge pressure does not rise to normal levels:

1. Turn off power to the unit. Install disconnect tag.
2. Reverse any two of the unit power leads.
3. Reapply power to the unit and verify pressures are correct.

The suction and discharge pressure levels should now move to their normal start-up levels.

When the compressor is rotating in the wrong direction, the unit makes more noise and does not provide cooling.

After a few minutes of reverse operation, the scroll compressor internal overload protection will open, thus activating the unit lockout. This requires a manual reset. To reset, turn the thermostat on and then off.

NOTE: There is a 5-minute time delay before the compressor will start.

Unit Start-Up Cooling Mode

1. Adjust the unit thermostat to the warmest position. Slowly reduce the thermostat position until the compressor activates.
2. Check for cool air delivery at unit grille a few minutes after the unit has begun to operate.
3. Verify that the compressor is on and that the water flow rate is correct by measuring pressure drop through the heat exchanger using P/T plugs. See Table 14. Check the elevation and cleanliness of the condensate lines; any dripping could be a sign of a blocked line. Be sure the condensate trap includes a water seal.
4. Check the temperature of both supply and discharge water. Compare to Tables 15-25. If temperature is within range, proceed. If temperature is outside the range, check the cooling refrigerant pressures in Tables 15-25.
5. Check air temperature drop across the coil when compressor is operating. Air temperature drop should be between 15 and 25 F.

Table 14 — Water Temperature Change Through Heat Exchanger

WATER FLOW RATE (GPM)	COOLING RISE (F)		HEATING DROP (F)	
	Min	Max	Min	Max
For Closed Loop: Ground Source or Cooling/Boiler Systems at 3 gpm/ton	9	12	4	8
For Open Loop: Ground Water Systems at 1.5 gpm/ton	20	26	10	17

Table 15 — 50PC006 Typical Unit Operating Pressures and Temperatures

ENTERING WATER TEMP (F)	WATER FLOW (GPM/ton)	COOLING						HEATING					
		Suction Pressure (psig)	Discharge Pressure (psig)	Super-heat (F)	Sub-cooling (F)	Water Temp Rise (F)	Air Temp Drop (F) DB	Suction Pressure (psig)	Discharge Pressure (psig)	Super-heat (F)	Sub-cooling (F)	Water Temp Drop (F)	Air Temp Rise (F) DB
30*	1.5	124-134	159-179	17-22	5-10	18.7-20.7	17-23	71- 81	295-315	13-18	5-10	5.9- 7.9	17-23
	2.25	120-130	147-167	20-25	5-10	13.6-15.6	18-24	72- 82	296-316	14-19	5-10	4.2- 6.2	17-23
	3	117-127	136-156	24-29	5-10	8.5-10.5	18-24	74- 84	297-317	15-20	5-10	2.5- 4.5	17-23
50	1.5	132-142	210-230	7-12	5-10	16.2-18.2	18-24	105-115	330-350	8-13	9-14	8.2-10.2	22-28
	2.25	131-141	199-219	8-13	5-10	11.9-13.9	19-25	110-120	335-355	9-14	9-14	6.1- 8.1	22-28
	3	130-140	189-209	9-14	4- 9	7.7- 9.7	19-25	115-125	339-359	9-14	9-14	4.0- 6.0	23-29
70	1.5	136-146	275-295	5-10	5-10	15.1-17.1	17-23	136-146	362-382	9-14	10-15	11.3-13.3	27-33
	2.25	136-146	262-282	6-11	4- 9	11.1-13.1	18-24	141-151	368-388	9-14	10-15	16.9-18.9	28-34
	3	135-145	250-270	6-11	4- 9	7.2- 9.2	18-24	147-157	374-394	9-14	10-15	5.6- 7.6	29-35
90	1.5	142-152	365-385	5-10	4- 9	13.8-15.8	16-22	170-180	402-422	14-19	12-17	14.4-16.4	33-39
	2.25	141-151	353-373	5-10	4- 9	10.2-12.2	16-22	173-183	407-427	15-20	12-17	11.1-13.1	33-39
	3	140-150	340-360	5-10	4- 9	6.6- 8.6	16-22	177-187	412-432	17-22	12-17	7.7- 9.7	34-40
110	1.5	148-158	462-482	5-10	4- 9	12.5-14.5	14-20	—	—	—	—	—	—
	2.25	147-157	449-469	5-10	3- 8	9.2-11.2	14-20	—	—	—	—	—	—
	3	146-156	438-458	5-10	3- 8	5.9- 7.9	14-20	—	—	—	—	—	—

LEGEND

DB — Dry Bulb
 — — No Heating Operation in This Temperature Range

*Based on 15% Methanol antifreeze solution.

Table 16 — 50PC009 Typical Unit Operating Pressures and Temperatures

ENTERING WATER TEMP (F)	WATER FLOW (GPM/ton)	COOLING						HEATING					
		Suction Pressure (psig)	Discharge Pressure (psig)	Super-heat (F)	Sub-cooling (F)	Water Temp Rise (F)	Air Temp Drop (F) DB	Suction Pressure (psig)	Discharge Pressure (psig)	Super-heat (F)	Sub-cooling (F)	Water Temp Drop (F)	Air Temp Rise (F) DB
30*	1.5	113-123	160-180	22-27	13-18	19.5-21.5	17-23	69- 79	331-351	11-16	20-25	7.3- 9.3	17-23
	2.25	110-120	147-167	25-30	11-16	14.2-16.2	17-23	72- 82	335-355	11-16	20-25	5.4- 7.4	18-24
	3	108-118	135-155	28-33	9-14	8.9-10.9	16-21	75- 85	339-359	11-16	21-26	3.5- 5.5	19-25
50	1.5	124-134	211-231	9-14	10-15	18.0-20.0	17-23	101-111	360-380	9-14	20-25	9.8-11.8	23-29
	2.25	122-132	199-219	12-17	9-14	13.2-15.2	17-23	105-115	363-383	9-14	19-24	7.4- 9.4	24-30
	3	120-130	187-207	15-20	8-13	8.4-10.4	17-23	110-120	366-386	9-14	19-24	4.9- 6.9	24-30
70	1.5	129-139	275-295	7-12	8-13	17.4-19.4	16-22	130-140	400-420	10-15	20-25	12.8-14.8	28-34
	2.25	128-138	261-281	8-13	7-12	12.8-14.8	16-22	137-147	407-427	10-15	19-24	9.6-11.6	29-35
	3	127-137	247-267	8-13	6-11	8.2-10.2	16-22	144-154	414-434	10-15	18-23	6.4- 8.4	30-36
90	1.5	136-146	364-384	7-12	3- 8	15.7-17.7	15-21	170-180	449-469	13-18	17-22	16.0-18.0	34-40
	2.25	135-145	350-370	7-12	4- 9	11.7-13.7	15-21	178-188	455-475	14-19	15-20	12.0-14.0	35-41
	3	134-144	336-356	7-12	4- 9	7.6- 9.6	15-21	186-196	460-480	15-20	13-18	7.9- 9.9	36-42
110	1.5	142-152	467-487	5-10	4- 9	13.5-15.5	13-19	—	—	—	—	—	—
	2.25	141-151	451-471	5-10	4- 9	9.9-11.9	13-19	—	—	—	—	—	—
	3	140-150	435-455	5-10	3- 8	6.3- 8.3	13-19	—	—	—	—	—	—

LEGEND

DB — Dry Bulb
 — — No Heating Operation in This Temperature Range

*Based on 15% Methanol antifreeze solution.

Table 17 — 50PC012 Typical Unit Operating Pressures and Temperatures

ENTERING WATER TEMP (F)	WATER FLOW (GPM/ton)	COOLING						HEATING					
		Suction Pressure (psig)	Discharge Pressure (psig)	Super-heat (F)	Sub-cooling (F)	Water Temp Rise (F)	Air Temp Drop (F) DB	Suction Pressure (psig)	Discharge Pressure (psig)	Super-heat (F)	Sub-cooling (F)	Water Temp Drop (F)	Air Temp Rise (F) DB
30*	1.5	116-126	155-175	14-19	9-14	19.4-21.4	18-24	70- 80	311-331	8-13	8-13	6.9- 8.9	18-24
	2.25	113-123	144-164	15-20	8-13	14.3-16.3	18-24	72- 82	315-335	8-13	8-13	5.1- 7.1	19-25
	3	111-121	132-152	17-22	6-11	9.1-11.1	18-24	75- 85	319-339	8-13	8-13	3.2- 5.2	19-25
50	1.5	123-133	208-228	8-13	9-14	18.1-20.1	17-23	102-112	354-364	8-13	9-14	9.3-11.3	25-31
	2.25	122-132	196-216	9-14	7-12	13.4-15.4	18-24	106-116	355-375	8-13	9-14	7.0- 9.0	26-32
	3	121-131	184-204	9-14	5-10	8.6-10.6	18-24	110-120	355-375	8-13	9-14	4.6- 6.6	26-32
70	1.5	127-137	266-286	7-12	8-13	17.2-19.2	16-22	131-141	392-412	9-14	8-13	12.0-14.0	30-36
	2.25	126-136	255-275	8-13	7-12	12.7-14.7	16-22	137-147	395-415	9-14	8-13	9.0-11.0	31-37
	3	126-136	244-264	8-13	5-10	8.2-10.2	16-22	144-154	398-418	9-14	7-12	6.0- 8.0	32-38
90	1.5	133-143	362-382	6-11	7-12	16.0-18.0	15-21	175-185	443-463	10-15	3- 8	15.0-17.0	36-42
	2.25	132-142	342-362	7-12	5-10	11.8-13.8	15-21	183-193	452-472	11-16	3- 8	11.2-13.2	37-43
	3	132-142	331-351	7-12	4- 9	7.6- 9.6	15-21	190-200	461-491	13-18	3- 8	7.4- 9.4	38-44
110	1.5	140-150	459-479	6-11	4- 9	14.4-16.4	13-19	—	—	—	—	—	—
	2.25	140-150	441-461	6-11	4- 9	10.6-12.6	13-19	—	—	—	—	—	—
	3	139-149	431-451	6-11	3- 8	6.9- 8.9	13-19	—	—	—	—	—	—

LEGEND

DB — Dry Bulb
 — — No Heating Operation in This Temperature Range

*Based on 15% Methanol antifreeze solution.

Table 18 — 50PC015 Typical Unit Operating Pressures and Temperatures

ENTERING WATER TEMP (F)	WATER FLOW (GPM/ton)	COOLING						HEATING					
		Suction Pressure (psig)	Discharge Pressure (psig)	Super-heat (F)	Sub-cooling (F)	Water Temp Rise (F)	Air Temp Drop (F) DB	Suction Pressure (psig)	Discharge Pressure (psig)	Super-heat (F)	Sub-cooling (F)	Water Temp Drop (F)	Air Temp Rise (F) DB
30*	1.5	116-126	167-187	15-20	9-14	18.3-20.3	18-24	70- 80	279-299	6-11	1-5	7.0- 8.0	16-22
	2.25	116-126	154-174	15-20	7-12	13.9-15.9	19-25	73- 83	281-301	7-12	1-5	5.1- 7.1	17-23
	3	116-126	140-160	15-20	7-12	9.5-11.5	19-25	75- 85	284-304	7-12	1-5	3.3- 5.3	17-23
50	1.5	128-138	194-214	11-14	9-14	17.9-19.9	18-24	102-112	312-332	10-15	2-6	9.9-11.9	22-28
	2.25	128-138	180-200	11-14	7-12	13.7-15.7	19-25	106-116	316-336	10-15	2-6	7.4- 9.4	23-29
	3	128-138	166-186	11-14	7-12	9.4-11.4	19-25	110-120	321-341	10-15	2-6	4.9- 6.9	23-29
70	1.5	136-146	289-309	7-12	9-14	17.4-19.4	17-23	128-138	335-355	12-17	3-8	12.9-14.9	27-34
	2.25	136-146	275-295	7-12	7-12	15.3-17.3	18-24	134-144	340-360	12-17	3-8	7.4- 11.7	28-35
	3	136-146	261-281	7-12	6-11	8.8-10.8	18-24	141-151	346-366	12-17	3-8	6.5- 8.5	28-35
90	1.5	139-149	386-406	6-11	9-14	16.8-18.8	16-22	160-170	373-393	15-20	3-8	15.8-17.8	30-38
	2.25	139-149	370-390	6-11	7-12	12.5-14.5	16-22	167-177	380-400	16-21	3-8	12.0-14.0	31-39
	3	139-149	356-376	6-11	6-11	8.2- 9.2	16-22	174-184	388-408	17-22	3-8	8.1-10.1	32-40
110	1.5	145-155	483-503	6-11	9-14	15.8-17.8	15-21	—	—	—	—	—	—
	2.25	144-154	466-486	6-11	7-12	11.7-13.7	15-21	—	—	—	—	—	—
	3	143-153	449-469	6-11	6-11	7.5- 9.5	15-21	—	—	—	—	—	—

LEGEND

DB — Dry Bulb
 — — No Heating Operation in This Temperature Range

*Based on 15% Methanol antifreeze solution.

Table 19 — 50PC018 Typical Unit Operating Pressures and Temperatures

ENTERING WATER TEMP (F)	WATER FLOW (GPM/ton)	COOLING						HEATING					
		Suction Pressure (psig)	Discharge Pressure (psig)	Super-heat (F)	Sub-cooling (F)	Water Temp Rise (F)	Air Temp Drop (F) DB	Suction Pressure (psig)	Discharge Pressure (psig)	Super-heat (F)	Sub-cooling (F)	Water Temp Drop (F)	Air Temp Rise (F) DB
30*	1.5	122-132	171-191	15-20	14-19	22.5-24.5	20-28	70- 80	272-292	4- 9	2- 6	7.4- 9.4	18-24
	2.25	122-132	157-177	15-20	13-18	16.8-19.8	20-28	73- 83	275-295	4- 9	2- 6	5.5- 7.5	19-25
	3	122-132	145-165	15-20	13-18	11.2-13.2	20-28	77- 87	278-298	4- 9	2- 6	3.5- 5.5	19-25
50	1.5	136-146	198-218	10-15	14-19	22.0-24.0	19-25	101-111	302-322	8-13	3- 7	10.3-12.3	23-29
	2.25	134-144	183-203	10-15	13-18	16.5-18.5	19-25	105-115	306-326	8-13	3- 7	7.9- 9.9	24-30
	3	133-143	171-191	11-16	13-18	11.0-13.0	19-25	109-119	311-331	8-13	3- 7	5.5- 7.5	25-31
70	1.5	139-149	293-313	6-10	14-19	19.0-21.0	18-24	130-140	329-349	10-15	4- 9	13.6-15.6	27-33
	2.25	138-148	280-300	6-10	13-18	14.4-16.4	18-24	137-147	337-357	10-15	4- 9	10.4-12.4	29-35
	3	137-147	267-287	7-11	13-18	9.8-11.7	18-24	139-149	342-362	10-15	4- 9	7.2- 9.2	30-36
90	1.5	142-152	389-409	5-10	17-22	16.0-18.0	17-23	160-170	360-380	13-18	5-10	17.0-19.0	33-41
	2.25	141-151	376-396	5-10	15-20	12.3-14.3	17-23	169-179	368-388	14-19	5-10	12.9-14.9	35-43
	3	140-150	363-383	5-10	13-18	8.5-10.5	17-23	178-188	376-396	14-19	4- 9	8.8-10.8	36-44
110	1.5	148-158	486-506	5-10	17-22	14.9-16.9	16-22	—	—	—	—	—	—
	2.25	147-157	472-492	5-10	15-20	11.4-13.4	16-22	—	—	—	—	—	—
	3	146-156	458-478	5-10	13-18	7.8- 9.8	16-22	—	—	—	—	—	—

LEGEND

DB — Dry Bulb
 — — No Heating Operation in This Temperature Range

*Based on 15% Methanol antifreeze solution.

Table 20 — 50PC024 Typical Unit Operating Pressures and Temperatures

ENTERING WATER TEMP (F)	WATER FLOW (GPM/ton)	COOLING						HEATING					
		Suction Pressure (psig)	Discharge Pressure (psig)	Super-heat (F)	Sub-cooling (F)	Water Temp Rise (F)	Air Temp Drop (F) DB	Suction Pressure (psig)	Discharge Pressure (psig)	Super-heat (F)	Sub-cooling (F)	Water Temp Drop (F)	Air Temp Rise (F) DB
30*	1.5	121-131	174-194	13-18	6-11	19.3-21.3	20-28	65- 75	287-307	4- 9	3-8	6.8- 8.8	17-23
	2.25	120-130	165-185	13-18	5-10	14.5-16.5	20-28	68- 78	290-310	5-10	3-8	5.0- 7.0	18-24
	3	120-130	155-175	13-18	5-10	9.6-11.6	20-28	71- 81	292-312	5-10	3-8	3.2- 5.2	18-24
50	1.5	127-137	245-265	8-13	6-11	18.3-20.3	19-27	96-106	318-338	6-11	3-8	9.8-11.8	22-28
	2.25	128-138	231-251	8-13	7-12	13.7-15.7	19-27	101-111	322-342	7-12	3-8	7.2- 9.2	23-29
	3	128-138	217-237	8-13	7-12	9.1-11.1	19-27	105-115	327-347	8-13	3-8	4.8- 6.8	24-30
70	1.5	130-140	352-372	6-11	8-13	17.5-19.5	18-26	127-137	349-369	9-14	3-8	12.7-14.7	27-34
	2.25	130-140	334-354	6-11	9-14	26.2-28.2	18-26	132-142	353-373	9-14	3-8	9.5-11.5	28-35
	3	130-140	306-326	6-11	9-14	8.7-10.7	18-26	137-147	358-378	10-15	3-8	6.3- 8.3	29-36
90	1.5	134-144	439-459	5-10	11-16	16.7-18.7	17-23	159-169	379-399	13-18	3-8	15.6-17.6	32-40
	2.25	133-143	416-436	5-10	12-17	12.5-14.5	17-23	164-174	384-404	14-19	3-8	11.7-13.7	33-41
	3	133-143	394-414	5-10	12-17	8.3-10.3	17-23	170-180	390-410	16-21	3-8	7.8- 9.8	34-42
110	1.5	140-150	536-556	4- 9	22-27	17.1-19.1	17-23	—	—	—	—	—	—
	2.25	139-149	512-532	4- 9	19-23	12.6-14.6	17-23	—	—	—	—	—	—
	3	138-148	488-508	4- 9	17-22	8.0-10.0	17-23	—	—	—	—	—	—

LEGEND

DB — Dry Bulb
 — — No Heating Operation in This Temperature Range

*Based on 15% Methanol antifreeze solution.

Table 21 — 50PC030 Typical Unit Operating Pressures and Temperatures

ENTERING WATER TEMP (F)	WATER FLOW (GPM/ton)	COOLING						HEATING					
		Suction Pressure (psig)	Discharge Pressure (psig)	Super-heat (F)	Sub-cooling (F)	Water Temp Rise (F)	Air Temp Drop (F) DB	Suction Pressure (psig)	Discharge Pressure (psig)	Super-heat (F)	Sub-cooling (F)	Water Temp Drop (F)	Air Temp Rise (F) DB
30*	1.5	113-123	188-208	14-19	14-19	19.5-21.5	18-26	67- 77	322-342	8-13	15-20	6.9- 8.9	17-25
	2.25	114-124	177-197	14-19	13-18	14.5-16.5	19-27	69- 79	324-344	8-13	15-20	5.1- 7.1	18-26
	3	114-124	166-186	14-19	13-18	9.5-11.5	19-27	71- 81	326-346	8-13	15-20	3.3- 5.3	18-26
50	1.5	124-134	248-268	11-16	14-19	18.7-20.7	18-26	95-105	346-366	10-15	15-20	9.8-11.8	23-31
	2.25	124-134	233-253	11-16	13-18	13.9-15.9	19-27	99-109	350-370	10-15	15-20	7.3- 9.3	24-32
	3	124-134	218-238	11-16	13-18	9.1-11.1	19-27	103-113	355-375	11-16	15-20	4.8- 6.8	25-33
70	1.5	132-142	333-353	9-14	13-18	17.5-19.5	18-26	125-135	376-396	13-18	14-19	12.7-14.7	27-35
	2.25	132-142	313-333	9-14	12-17	13.0-15.0	18-26	133-143	386-406	13-18	14-19	9.8-11.8	28-36
	3	132-142	293-313	9-14	12-17	8.5-10.5	18-26	136-146	393-413	13-18	14-19	6.4- 8.4	30-38
90	1.5	135-145	431-451	7-12	17-22	16.5-18.5	17-25	155-165	415-435	15-20	13-18	15.6-18.6	33-41
	2.25	135-145	411-431	7-12	15-20	12.3-14.3	17-25	167-177	422-442	16-21	13-18	11.8-13.8	34-42
	3	135-145	391-411	7-12	13-18	8.0-10.0	17-25	170-180	430-450	17-22	13-18	7.9- 9.9	36-44
110	1.5	140-150	528-548	6-11	17-22	16.2-18.2	16-24	—	—	—	—	—	—
	2.25	140-150	506-526	7-12	15-20	11.9-13.9	16-24	—	—	—	—	—	—
	3	139-149	485-505	7-12	13-18	7.6- 9.6	16-24	—	—	—	—	—	—

LEGEND

DB — Dry Bulb
 — — No Heating Operation in This Temperature Range

*Based on 15% Methanol antifreeze solution.

Table 22 — 50PC036 Typical Unit Operating Pressures and Temperatures

ENTERING WATER TEMP (F)	WATER FLOW (GPM/ton)	COOLING						HEATING					
		Suction Pressure (psig)	Discharge Pressure (psig)	Super-heat (F)	Sub-cooling (F)	Water Temp Rise (F)	Air Temp Drop (F) DB	Suction Pressure (psig)	Discharge Pressure (psig)	Super-heat (F)	Sub-cooling (F)	Water Temp Drop (F)	Air Temp Rise (F) DB
30*	1.5	113-123	185-205	17-22	9-14	19.5-21.5	18-26	64- 74	327-347	4- 9	15-20	7.7- 9.7	19-27
	2.25	113-123	174-194	17-22	8-13	14.5-16.5	19-27	66- 76	331-351	4- 9	15-20	5.7- 7.7	19-27
	3	113-123	163-183	17-22	8-13	9.6-11.6	19-27	69- 79	335-365	4- 9	15-20	3.7- 5.7	20-28
50	1.5	121-131	249-269	12-17	9-14	19.4-21.4	17-25	91-101	360-380	10-15	15-20	11.2-13.2	25-33
	2.25	120-130	231-251	12-17	8-13	14.4-16.4	18-26	96-106	370-390	9-14	16-21	8.2-10.2	26-34
	3	120-130	214-234	12-17	8-13	9.4-11.4	18-26	102-112	380-400	8-13	16-21	5.2- 7.2	27-35
70	1.5	128-138	327-347	9-14	13-18	19.1-21.1	16-24	125-135	402-422	10-15	14-19	14.7-16.7	32-40
	2.25	128-138	304-324	9-14	11-16	14.1-16.1	17-25	132-142	413-433	10-15	14-19	11.0-13.0	33-41
	3	127-137	282-302	9-14	10-15	9.1-11.1	17-25	140-150	423-443	10-15	14-19	7.3- 9.3	34-42
90	1.5	132-142	416-436	8-13	20-25	18.8-20.8	15-23	158-168	445-465	13-18	12-17	18.1-20.1	37-45
	2.25	132-142	396-416	8-13	18-23	13.9-15.9	16-24	167-177	456-476	13-18	11-16	13.8-15.8	38-46
	3	131-141	376-396	8-13	16-21	8.9-10.9	16-24	177-187	467-487	14-19	11-16	9.4-11.4	40-48
110	1.5	138-148	550-570	8-13	20-25	18.5-20.5	15-23	—	—	—	—	—	—
	2.25	136-146	525-545	8-13	18-23	13.6-15.6	15-23	—	—	—	—	—	—
	3	135-145	500-520	8-13	16-21	8.7-10.7	15-23	—	—	—	—	—	—

LEGEND

DB — Dry Bulb
 — — No Heating Operation in This Temperature Range

*Based on 15% Methanol antifreeze solution.

Table 23 — 50PC042 Typical Unit Operating Pressures and Temperatures

ENTERING WATER TEMP (F)	WATER FLOW (GPM/ton)	COOLING						HEATING					
		Suction Pressure (psig)	Discharge Pressure (psig)	Super-heat (F)	Sub-cooling (F)	Water Temp Rise (F)	Air Temp Drop (F) DB	Suction Pressure (psig)	Discharge Pressure (psig)	Super-heat (F)	Sub-cooling (F)	Water Temp Drop (F)	Air Temp Rise (F) DB
30*	1.5	115-125	174-194	12-17	10-15	19.8-21.8	16-24	66- 76	314-334	6-11	11-16	7.3- 9.3	18-26
	2.25	115-125	159-179	12-17	9-14	14.6-16.6	16-24	69- 79	318-338	5-10	12-17	5.4- 7.4	19-27
	3	115-125	144-164	12-17	9-14	9.5-11.5	16-24	72- 82	321-341	4- 9	12-17	3.4- 5.4	19-27
50	1.5	123-133	233-253	9-14	10-15	19.0-21.0	16-24	97-107	354-374	9-14	13-18	10.2-12.2	24-32
	2.25	122-132	219-239	9-14	9-14	14.0-16.0	16-24	101-111	360-380	8-13	13-18	7.6- 9.6	25-33
	3	122-132	205-225	9-14	9-14	9.1-11.1	16-24	106-116	365-385	6-11	13-18	5.0- 7.0	26-34
70	1.5	128-138	309-329	6-11	12-17	18.3-20.3	16-24	130-140	394-414	7-12	13-18	13.3-15.3	30-38
	2.25	128-138	290-310	6-11	11-14	13.5-15.5	16-24	136-146	401-421	7-12	13-18	9.9-11.9	31-39
	3	128-138	271-291	6-11	11-14	8.7-10.7	16-24	143-153	409-429	8-13	13-18	6.6- 8.6	32-40
90	1.5	133-143	406-426	5-10	14-19	17.6-19.6	16-24	164-174	434-454	10-15	12-17	16.4-18.4	37-45
	2.25	133-143	386-406	5-10	13-18	12.9-14.9	16-24	172-182	443-463	11-16	12-17	12.3-14.3	38-46
	3	132-142	367-387	5-10	13-18	8.3-10.3	16-24	180-190	453-473	11-16	12-17	8.3-10.3	39-47
110	1.5	138-148	505-525	5-10	19-24	16.8-18.8	16-24	—	—	—	—	—	—
	2.25	138-148	484-504	5-10	16-21	12.4-14.4	16-24	—	—	—	—	—	—
	3	138-148	463-483	5-10	14-19	7.9- 9.9	16-24	—	—	—	—	—	—

LEGEND

DB — Dry Bulb
 — — No Heating Operation in This Temperature Range

*Based on 15% Methanol antifreeze solution.

Table 24 — 50PC048 Typical Unit Operating Pressures and Temperatures

ENTERING WATER TEMP (F)	WATER FLOW (GPM/ton)	COOLING						HEATING					
		Suction Pressure (psig)	Discharge Pressure (psig)	Super-heat (F)	Sub-cooling (F)	Water Temp Rise (F)	Air Temp Drop (F) DB	Suction Pressure (psig)	Discharge Pressure (psig)	Super-heat (F)	Sub-cooling (F)	Water Temp Drop (F)	Air Temp Rise (F) DB
30*	1.5	119-129	190-210	15-20	10-15	19.3-21.3	18-26	63- 73	284-304	5-10	3-8	6.9- 8.9	17-25
	2.25	119-129	179-199	15-20	9-14	14.6-16.6	19-27	66- 76	288-308	6-10	3-8	5.0- 7.0	18-26
	3	119-129	158-178	15-20	9-14	9.8-11.8	19-27	69- 79	292-312	6-11	3-8	3.1- 5.1	18-26
50	1.5	124-134	248-268	10-15	10-15	19.0-21.0	18-26	92-102	309-329	8-13	3-8	9.5-11.5	23-31
	2.25	123-133	230-250	10-15	9-14	14.3-16.3	19-27	96-106	313-333	9-14	3-8	7.0- 9.0	24-32
	3	123-133	213-233	10-15	9-14	9.6-11.6	19-27	100-110	317-337	9-14	3-8	4.6- 6.6	24-32
70	1.5	129-139	337-357	8-13	12-17	18.6-20.6	17-25	123-133	339-359	11-16	3-8	12.5-14.5	29-37
	2.25	129-139	328-348	8-13	11-16	14.0-16.0	18-26	128-138	344-364	11-16	3-8	9.3-11.3	29-37
	3	129-139	300-320	8-13	11-16	9.4-11.4	18-26	133-143	350-370	12-17	3-8	6.2- 8.2	30-38
90	1.5	134-144	426-446	6-11	15-20	18.2-20.2	16-24	153-163	369-389	14-19	1-6	15.4-17.4	33-41
	2.25	134-144	406-426	6-11	15-20	13.7-15.7	17-25	160-170	376-396	15-20	1-6	11.6-13.6	35-43
	3	134-144	386-406	6-11	15-20	9.2-11.2	17-25	167-177	384-404	16-21	1-6	7.8- 9.8	36-44
110	1.5	140-150	560-580	4- 9	23-28	17.7-19.7	16-24	—	—	—	—	—	—
	2.25	140-150	536-556	4- 9	20-25	13.4-15.4	16-24	—	—	—	—	—	—
	3	139-149	511-531	4- 9	18-22	9.0-11.0	16-24	—	—	—	—	—	—

LEGEND

DB — Dry Bulb
 — — No Heating Operation in This Temperature Range

*Based on 15% Methanol antifreeze solution.

Table 25 — 50PC060 Typical Unit Operating Pressures and Temperatures

ENTERING WATER TEMP (F)	WATER FLOW (GPM/ton)	COOLING						HEATING					
		Suction Pressure (psig)	Discharge Pressure (psig)	Super-heat (F)	Sub-cooling (F)	Water Temp Rise (F)	Air Temp Drop (F) DB	Suction Pressure (psig)	Discharge Pressure (psig)	Super-heat (F)	Sub-cooling (F)	Water Temp Drop (F)	Air Temp Rise (F) DB
30*	1.5	108-118	180-200	16-21	10-15	20.6	19-27	61- 71	314-334	6-11	14-19	7.6- 9.6	19-27
	2.25	108-118	165-185	16-21	9-14	15.2-17.2	20-28	64- 74	317-337	7-12	13-18	5.6- 7.6	20-28
	3	108-118	150-170	16-21	9-14	9.7-11.7	20-28	66- 76	319-339	7-12	13-18	3.6- 5.6	20-28
50	1.5	113-123	206-226	11-14	10-15	19.8-21.8	18-26	90-100	350-370	11-16	14-19	10.5-12.5	25-33
	2.25	113-123	190-210	11-14	9-14	14.5-16.5	19-27	95-105	357-377	11-16	14-19	7.9- 9.9	27-35
	3	113-123	173-193	11-14	9-14	9.3-11.3	19-27	99-109	364-384	10-15	14-19	5.2- 7.2	28-36
70	1.5	119-129	305-325	9-14	12-17	18.8-20.8	17-25	123-133	391-411	12-17	14-19	13.7-15.7	33-41
	2.25	118-128	287-307	9-14	11-14	13.8-15.8	18-26	129-139	399-419	12-17	14-19	10.3-12.3	34-42
	3	118-128	269-289	9-14	11-14	8.8-10.8	18-26	135-145	407-427	13-18	14-19	6.9- 8.9	35-43
90	1.5	124-134	402-422	7-12	14-19	17.8-19.8	16-24	157-167	431-451	13-18	13-18	16.8-18.8	38-46
	2.25	124-134	382-402	7-12	13-18	13.1-15.1	17-25	164-184	440-460	14-19	13-18	12.7-14.7	39-47
	3	123-133	363-383	7-12	13-18	8.3-10.3	17-25	172-182	450-470	16-21	12-17	8.6-10.6	41-49
110	1.5	130-140	500-520	7-12	20-25	17.0-19.0	16-24	—	—	—	—	—	—
	2.25	129-139	479-499	6-11	16-21	12.4-14.4	16-24	—	—	—	—	—	—
	3	128-138	458-478	5-10	13-18	7.8- 9.8	16-24	—	—	—	—	—	—

LEGEND

DB — Dry Bulb
 — — No Heating Operation in This Temperature Range

*Based on 15% Methanol antifreeze solution.

Unit Start-Up Heating Mode

NOTE: Operate the unit in heating cycle after checking the cooling cycle. Allow 5 minutes between tests for the pressure or reversing valve to equalize.

1. Turn thermostat to lowest setting and set thermostat switch to HEAT position.
2. Slowly turn the thermostat to a higher temperature until the compressor activates.
3. Check for warm air delivery at the unit grille within a few minutes after the unit has begun to operate.
4. Check the temperature of both supply and discharge water. Compare to Tables 15-25. If temperature is within range, proceed. If temperature is outside the range, check the heating refrigerant pressures in Tables 15-25.
5. Once the unit has begun to run, check for warm air delivery at the unit grille.
6. Check air temperature rise across the coil when compressor is operating. Air temperature rise should be between 20 and 30 F after 15 minutes at load.
7. Check for vibration, noise and water leaks.

Unit Start-Up with WSHP Open Controls —

The WSHP Open is a multi-protocol (default BACnet*) controller with extensive features, flexible options and powerful capabilities. The unit comes from the factory pre-programmed and needs minimal set up to function in a BAS (Building Automation System) system or provide additional capabilities to Carrier's WSHP product line. Most settings on the controller have factory defaults set for ease of installation. There are a few settings that must be configured in the field and several settings that can be adjusted if required by unique job conditions. Refer to Appendix A — WSHP Open Screen Configuration. In order to configure the unit, a BACview⁶ display is required. See Fig. 29.

NOTE: If the WSHP Open control has lost its programming, all display pixels will be displayed on the SPT sensor. See the WSHP Third Party Integration Guide.

When the unit is OFF, the SPT sensor will indicate OFF. When power is applied, the SPT sensor will indicate temperature in the space at 78 F.

*Sponsored by ASHRAE (American Society of Heating, Refrigerating and Air Conditioning Engineers).

To start-up a unit with WSHP Open controls:

1. To plug in the BACview⁶ handheld display into a SPT sensor, point the two ears on the connector up and tilt the bottom of the plug toward you. Insert the plug up into the SPT sensor while pushing the bottom of the plug away from you.

2. BACview⁶ should respond with "Establishing Connection." The Home screen will then appear on the display showing operating mode and space temperature. Press any button to continue.

See Appendix A — WSHP Open Screen Configuration for the hierarchal structure of the WSHP Open controller. All functions of the controller can be set from the Home screen.

3. When the Login is requested, type 1111 and push the OK softkey. The Logout will then be displayed to indicate the password was accepted.

4. To set the Clock if it is not already displayed:
 - a. Select System Settings from the Home screen, then press Clockset.
 - b. Scroll to hour, minute and second using the arrow keys. Use the number keypad to set actual time.
 - c. Scroll to day, month and year using arrow keys. Use number keypad to set date.

5. To set Daylight Savings Time (DST):
 - a. Push the DST softkey. The display will indicate 02:00:060 which is equal to 2:00AM.
 - b. To program the beginning and end dates, scroll down to the beginning month and press the enter key. The softkeys (INCR and DECR) will activate to increment the month in either direction, Jan, Feb, March, etc.
 - c. Use number keys to select the day of month and year.
 - d. Push the OK softkey to finalize the data.

6. To view configuration settings:
 - a. Select the Config softkey.
 - b. Select the Service Config softkey. Scroll through the factory settings by using the up and down arrow keys. See below for factory settings. Only the following settings will need to be checked.

- # of Fan Speeds — This should be set to "1" for units with PSC motors and set to "3" for units with ECM motors.
- Compressor Stages — This should be set to "1."
- Factory Dehumidification Reheat Coil — This should be set to "none" unless the modulating hot water reheat option is supplied in the unit, then set to "installed."
- The condenser water limit needs to be verified depending on design parameters and application, whether geothermal or boiler/tower.

7. To view unit configuration settings:
 - a. Select Unit Configuration softkey, then select Unit.
 - b. Scroll through the unit settings by using the up and down arrow keys. Unit settings include:
 - Fan Mode: Default Continuous
 - Fan Delay:
 - Minimum SAT Cooling: Default 50 F
 - Maximum SAT Heating: Default 110 F
 - Filter Service Alarm: Must be set from 0 to 9999 hr
8. To set local schedules:
 - a. Select the Schedule softkey from the Configuration screen, then press enter.
 - b. Select Weekly, then press enter (7 schedules available).
 - c. Select day and press enter.
 - d. Press enter again and select ADD or DEL (DECR or INCR) set schedule.
 - e. Enter ON/OFF time, then press continue.
 - f. Press OK to apply and save to a particular day of the week.
 - g. Continue to add the same or different schedule specific days of the week.

To add exceptions to the schedule:

 - i. Press Add softkey.
 - ii. Select exception type from following:
 - Date
 - Date Range
 - Week-N-Day
 - Calender Reference
9. Go back to Home Screen.
10. Remove BACview⁶ cable from SPT sensor by reversing the process in Step 1.
11. Perform system test.

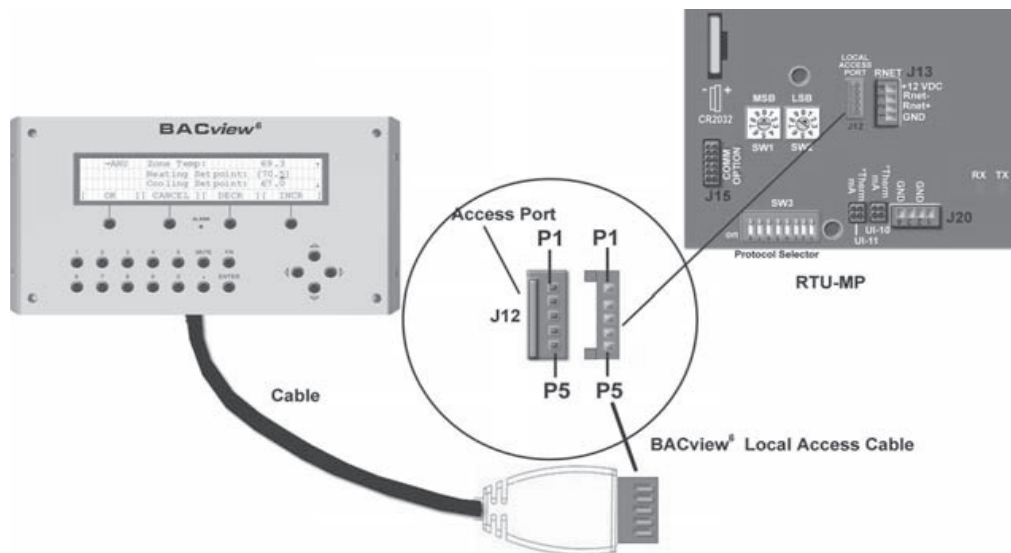

Fig. 29 — BACview⁶ Display Interface

Flow Regulation — Flow regulation can be accomplished by two methods. Most water control valves have a flow adjustment built into the valve. By measuring the pressure drop through the unit heat exchanger, the flow rate can be determined. See Table 26. Adjust the water control valve until the flow of 1.5 to 2 gpm is achieved. Since the pressure constantly varies, two pressure gages may be needed in some applications.

An alternative method is to install a flow control device. These devices are typically an orifice of plastic material designed to allow a specified flow rate that are mounted on the outlet of the water control valve. Occasionally these valves produce a velocity noise that can be reduced by applying some back pressure. To accomplish this, slightly close the leaving isolation valve of the well water setup.

⚠ WARNING

To avoid possible injury or death due to electrical shock, open the power supply disconnect switch and secure it in an open position before flushing system.

Flushing — Once the piping is complete, units require final purging and loop charging. A flush cart pump of at least 1.5 hp is needed to achieve adequate flow velocity in the loop to purge air and dirt particles from the loop. Flush the loop in both directions with a high volume of water at a high velocity. Follow the steps below to properly flush the loop:

1. Verify power is off.
2. Fill loop with water from hose through flush cart before using flush cart pump to ensure an even fill. Do not allow the water level in the flush cart tank to drop below the pump inlet line to prevent air from filling the line.
3. Maintain a fluid level in the tank above the return tee to avoid air entering back into the fluid.
4. Shutting off the return valve that connects into the flush cart reservoir will allow 50 psig surges to help purge air pockets. This maintains the pump at 50 psig.
5. To purge, keep the pump at 50 psig until maximum pumping pressure is reached.
6. Open the return valve to send a pressure surge through the loop to purge any air pockets in the piping system.
7. A noticeable drop in fluid level will be seen in the flush cart tank. This is the only indication of air in the loop.

NOTE: If air is purged from the system while using a 10 in. PVC flush tank, the level drop will only be 1 to 2 in. since liquids are incompressible. If the level drops more than this, flushing should continue since air is still being compressed in the loop. If level is less than 1 to 2 in., reverse the flow.

8. Repeat this procedure until all air is purged.
9. Restore power.

Antifreeze may be added before, during or after the flushing process. However, depending on when it is added in the process, it can be wasted. Refer to the Antifreeze section for more detail.

Loop static pressure will fluctuate with the seasons. Pressures will be higher in the winter months than during the warmer months. This fluctuation is normal and should be considered when charging the system initially. Run the unit in either heating or cooling for several minutes to condition the loop to a homogenous temperature.

When complete, perform a final flush and pressurize the loop to a static pressure of 40 to 50 psig for winter months or 15 to 20 psig for summer months.

After pressurization, be sure to remove the plug from the end of the loop pump motor(s) to allow trapped air to be discharged and to ensure the motor housing has been flooded. Be sure the loop flow center provides adequate flow through

the unit by checking pressure drop across the heat exchanger. Compare the results to the data in Table 26.

Table 26 — Coaxial Water Pressure Drop

50PC UNIT SIZE	gpm	L/s	PRESSURE DROP, psi (kPa)			
			30 F (-1 C)	50 F (10 C)	70 F (21 C)	90 F (32 C)
006	0.75	0.05	0.5 (3.7)	0.3 (2.3)	0.2 (1.6)	0.2 (1.6)
	1.1	0.07	0.8 (5.3)	0.5 (3.5)	0.4 (2.7)	0.3 (2.2)
	1.5	0.09	1.3 (8.8)	0.9 (6.1)	0.7 (4.8)	0.6 (4.0)
009	1.1	0.07	1.3 (9.0)	0.6 (4.4)	0.4 (2.8)	0.3 (1.9)
	1.8	0.11	2.1 (14.1)	1.4 (9.4)	1.1 (7.4)	0.9 (6.2)
	2.3	0.14	3.5 (24.3)	2.6 (17.9)	2.1 (14.7)	1.8 (12.7)
012	1.5	0.09	1.9 (12.8)	1.1 (7.6)	0.8 (5.3)	0.6 (4.1)
	2.3	0.15	3.6 (25.0)	2.6 (17.8)	2.1 (14.3)	1.8 (12.1)
	3.0	0.19	6.7 (46.1)	5.0 (34.3)	4.1 (28.3)	3.6 (24.5)
015	1.9	0.12	1.0 (6.9)	0.6 (4.4)	0.5 (3.4)	0.4 (2.8)
	2.8	0.18	1.8 (12.4)	1.4 (9.3)	1.1 (7.6)	1.0 (6.9)
	3.8	0.24	3.3 (22.7)	2.5 (17.5)	2.1 (14.7)	1.9 (13.1)
018	2.3	0.14	2.1 (14.5)	1.4 (9.9)	1.1 (7.6)	0.9 (6.2)
	3.4	0.21	3.4 (23.4)	2.6 (17.6)	2.1 (14.7)	1.8 (12.4)
	4.5	0.28	5.9 (40.6)	4.6 (31.5)	3.9 (26.9)	3.4 (23.4)
024	3.0	0.19	2.2 (15.2)	1.7 (11.6)	1.4 (9.6)	1.2 (8.3)
	4.5	0.28	4.0 (27.6)	3.2 (22.2)	2.8 (19.3)	2.5 (17.2)
	6.0	0.38	7.2 (49.6)	5.9 (40.6)	5.2 (35.8)	4.7 (32.4)
030	3.8	0.24	1.3 (9.0)	0.9 (6.1)	0.7 (4.8)	0.6 (4.1)
	5.6	0.35	2.3 (15.8)	1.8 (12.5)	1.5 (10.3)	1.4 (9.6)
	7.5	0.47	4.2 (28.9)	3.4 (23.2)	2.9 (20.0)	2.6 (17.9)
036	4.5	0.28	1.8 (12.4)	1.4 (9.6)	1.2 (8.3)	1.0 (6.9)
	6.8	0.43	3.1 (21.4)	2.4 (16.8)	2.1 (14.7)	1.9 (13.1)
	9.0	0.57	5.4 (37.2)	4.4 (30.0)	3.8 (26.2)	3.4 (23.4)
042	5.3	0.33	2.3 (15.8)	1.8 (12.1)	1.5 (10.3)	1.3 (9.0)
	7.9	0.50	4.3 (29.6)	3.5 (24.2)	3.1 (26.4)	2.8 (19.3)
	10.5	0.66	7.9 (54.4)	6.5 (44.8)	5.7 (39.3)	5.2 (35.8)
048	6.0	0.38	1.8 (12.4)	1.5 (10.1)	1.3 (9.0)	1.2 (8.3)
	9.0	0.57	3.4 (23.4)	3.0 (20.4)	2.7 (18.6)	2.6 (17.9)
	12.0	0.76	6.2 (42.7)	5.5 (37.9)	5.1 (35.1)	4.8 (35.1)
060	7.5	0.47	3.4 (23.4)	2.8 (19.2)	2.4 (16.5)	2.2 (15.2)
	11.3	0.71	6.8 (46.9)	5.9 (40.8)	5.4 (37.2)	5.0 (34.5)
	15.0	0.95	12.6 (86.8)	11.1(76.8)	10.3(71.0)	9.6 (66.1)

Antifreeze — In areas where entering loop temperatures drop below 40 F or where piping will be routed through areas subject to freezing, antifreeze is needed.

Alcohols and glycols are commonly used as antifreeze agents. Freeze protection should be maintained to 15 F below the lowest expected entering loop temperature. For example, if the lowest expected entering loop temperature is 30 F, the leaving loop temperature would be 22 to 25 F. Therefore, the freeze protection should be at 15 F (30 F – 15 F = 15 F).

IMPORTANT: All alcohols should be pre-mixed and pumped from a reservoir outside of the building or introduced under water level to prevent fuming.

Calculate the total volume of fluid in the piping system. See Table 27. Use the percentage by volume in Table 28 to determine the amount of antifreeze to use. Antifreeze concentration should be checked from a well mixed sample using a hydrometer to measure specific gravity.

FREEZE PROTECTION SELECTION — The 30 F FP1 factory setting (water) should be used to avoid freeze damage to the unit.

Once antifreeze is selected, the JW3 jumper (FP1) should be clipped on the control to select the low temperature (antifreeze 13 F) set point to avoid nuisance faults.

Cooling Tower/Boiler Systems — These systems typically use a common loop temperature maintained at 60 to 90 F. Carrier recommends using a closed circuit evaporative cooling tower with a secondary heat exchanger between the tower and

the water loop. If an open type cooling tower is used continuously, chemical treatment and filtering will be necessary.

Table 27 — Approximate Fluid Volume (gal.) per 100 Ft of Pipe

PIPE	DIAMETER (in.)	VOLUME (gal.)
Copper	1	4.1
	1.25	6.4
	1.5	9.2
Rubber Hose	1	3.9
Polyethylene	3/4 IPS SDR11	2.8
	1 IPS SDR11	4.5
	1 1/4 IPS SDR11	8.0
	1/2 IPS SDR11	10.9
	2 IPS SDR11	18.0
	1 1/4 IPS SCH40	8.3
	1 1/2 IPS SCH40	10.9
	2 IPS SCH40	17.0

LEGEND

- IPS — Internal Pipe Size
- SCH — Schedule
- SDR — Standard Dimensional Ratio

NOTE: Volume of heat exchanger is approximately 1.0 gallon.

Table 28 — Antifreeze Percentages by Volume

ANTIFREEZE	MINIMUM TEMPERATURE FOR FREEZE PROTECTION (F)			
	10	15	20	25
Methanol (%)	25	21	16	10
100% USP Food Grade Propylene Glycol (%)	38	30	22	15
Ethanol (%)	29	25	20	14

OPERATION

Power Up Mode — The unit will not operate until all the inputs, terminals and safety controls are checked for normal operation.

NOTE: The compressor will have a 5-minute anti-short cycle upon power up.

Units with Aquazone™ Complete C Control

STANDBY — Y and W terminals are not active in standby mode, however the O and G terminals may be active, depending on the application. The compressor will be off.

COOLING — Y and O terminals are active in Cooling mode. After power up, the first call to the compressor will initiate a 5 to 80 second random start delay and a 5-minute anti-short cycle protection time delay. After both delays are complete, the compressor is energized.

NOTE: On all subsequent compressor calls the random start delay is omitted.

HEATING STAGE 1 — Terminal Y is active in heating stage 1. After power up, the first call to the compressor will initiate a 5 to 80 second random start delay and a 5-minute anti-short cycle protection time delay. After both delays are complete, the compressor is energized.

NOTE: On all subsequent compressor calls the random start delay is omitted.

HEATING STAGE 2 — To enter Stage 2 mode, terminal W is active (Y is already active). Also, the G terminal must be active or the W terminal is disregarded. The compressor relay will remain on and EH1 is immediately turned on. EH2 will turn on after 10 minutes of continual stage 2 demand.

NOTE: EH2 will not turn on (or if on, will turn off) if FP1 temperature is greater than 45 F and FP2 is greater than 110 F.

EMERGENCY HEAT — In emergency heat mode, terminal W is active while terminal Y is not. Terminal G must be active or the W terminal is disregarded. EH1 is immediately turned on. EH2 will turn on after 5 minutes of continual emergency heat demand.

Units with Aquazone™ Deluxe D Control

STANDBY/FAN ONLY — The compressor will be off. The Fan Enable, Fan Speed, and reversing valve (RV) relays will be on if inputs are present. If there is a Fan 1 demand, the Fan Enable will immediately turn on. If there is a Fan 2 demand, the Fan Enable and Fan Speed will immediately turn on.

NOTE: DIP switch 5 on S1 does not have an effect upon Fan 1 and Fan 2 outputs.

HEATING STAGE 1 — In Heating Stage 1 mode, the Fan Enable and Compressor relays are turned on immediately. Once the demand is removed, the relays are turned off and the control reverts to Standby mode. If there is a master/slave or dual compressor application, all compressor relays and related functions will operate per their associated DIP switch 2 setting on S1.

HEATING STAGE 2 — In Heating Stage 2 mode, the Fan Enable and Compressor relays are remain on. The Fan Speed relay is turned on immediately and turned off immediately once the demand is removed. The control reverts to Heating Stage 1 mode. If there is a master/slave or dual compressor application, all compressor relays and related functions will operate per their associated DIP switch 2 setting on S1.

HEATING STAGE 3 — In Heating Stage 3 mode, the Fan Enable, Fan Speed and Compressor relays remain on. The EH1 output is turned on immediately. With continuing Heat Stage 3 demand, EH2 will turn on after 10 minutes. EH1 and EH2 are turned off immediately when the Heating Stage 3 demand is removed. The control reverts to Heating Stage 2 mode.

Output EH2 will be off if FP1 is greater than 45 F AND FP2 (when shorted) is greater than 110 F during Heating Stage 3 mode. This condition will have a 30-second recognition time. Also, during Heating Stage 3 mode, EH1, EH2, Fan Enable, and Fan Speed will be ON if G input is not active.

EMERGENCY HEAT — In Emergency Heat mode, the Fan Enable and Fan Speed relays are turned on. The EH1 output is turned on immediately. With continuing Emergency Heat demand, EH2 will turn on after 5 minutes. Fan Enable and Fan Speed relays are turned off after a 60-second delay. The control reverts to Standby mode.

Output EH1, EH2, Fan Enable, and Fan Speed will be ON if the G input is not active during Emergency Heat mode.

COOLING STAGE 1 — In Cooling Stage 1 mode, the Fan Enable, compressor and RV relays are turned on immediately. If configured as stage 2 (DIP switch set to OFF) then the compressor and fan will not turn on until there is a stage 2 demand. The fan Enable and compressor relays are turned off immediately when the Cooling Stage 1 demand is removed. The control reverts to Standby mode. The RV relay remains on until there is a heating demand. If there is a master/slave or dual compressor application, all compressor relays and related functions will track with their associated DIP switch 2 on S1.

COOLING STAGE 2 — In Cooling Stage 2 mode, the Fan Enable, compressor and RV relays remain on. The Fan Speed relay is turned on immediately and turned off immediately once the Cooling Stage 2 demand is removed. The control reverts to Cooling Stage 1 mode. If there is a master/slave or dual compressor application, all compressor relays and related functions will track with their associated DIP switch 2 on S1.

NIGHT LOW LIMIT (NLL) STAGED HEATING — In NLL staged Heating mode, the override (OVR) input becomes active and is recognized as a call for heating and the control will immediately go into a Heating Stage 1 mode. With an additional 30 minutes of NLL demand, the control will go into Heating Stage 2 mode. With another additional 30 minutes of NLL demand, the control will go into Heating Stage 3 mode.

Units with WSHP Open Multiple Protocol —

The WSHP Open multi-protocol controller will control mechanical cooling, heating and waterside economizer outputs based on its own space temperature input and set points. An

optional CO₂ IAQ (indoor air quality) sensor mounted in the space can maximize the occupant comfort. The WSHP Open controller has its own hardware clock that is automatically set when the heat pump software is downloaded to the board. Occupancy types are described in the scheduling section below. The following sections describe the functionality of the WSHP Open multi-protocol controller. All point objects referred to in this sequence of operation will be referenced to the objects as viewed in the BACview⁶ handheld user interface.

SCHEDULING — Scheduling is used to start/stop the unit based on a time period to control the space temperature to specified occupied heating and cooling set points. The controller is defaulted to control by occupied set points all the time, until either a time schedule is configured with BACview⁶, Field Assistant, i-Vu[®] Open, or a third party control system to enable/disable the BAS (Building Automation System) on/off point. The local time and date must be set for these functions to operate properly. The occupancy source can be changed to one of the following:

Occupancy Schedules — The controller will be occupied 24/7 until a time schedule has been configured using either Field Assistant, i-Vu Open, BACview⁶ or a third party control system to enable/disable the BAS on/off point. The BAS point can be disabled by going to Config, then Unit, then Occupancy Schedules and changing the point from enable to disable then clicking OK.

NOTE: This point must be enabled in order for the i-Vu Open, Field Assistant, or BACview⁶ control system to assign a time schedule to the controller.

Schedule schedule — The unit will operate according to the schedule configured and stored in the unit. The schedule is accessible via the BACview⁶ Handheld tool, i-Vu Open, or Field Assistant control system. The daily schedule consists of a start/stop time (standard or 24-hour mode) and seven days of the week, starting with Monday and ending on Sunday. To enter a daily schedule, navigate to Config, then Sched, then enter BACview⁶ Admin Password (1111), then go to schedule_schedule. From here, enter either a Weekly or Exception schedule for the unit.

Occupancy Input Contact — The WSHP Open controller has the capability to use an external dry contact closure to determine the occupancy status of the unit. The Occupancy Schedules will need to be disabled in order to utilize the occupancy contact input.

NOTE: Scheduling can only be controlled from one source.

BAS (Building Automation System) On/Off — A BAS system that supports network scheduling can control the unit through a network communication and the BAS scheduling function once the Occupancy Schedules have been disabled.

NOTE: Scheduling can either be controlled via the unit or the BAS, but not both.

INDOOR FAN — The indoor fan will operate in any one of three modes depending on the user configuration selected.

Fan mode can be selected as Auto, Continuous, or Always On. In Auto mode, the fan is in intermittent operation during both occupied and unoccupied periods. Continuous fan mode is intermittent during unoccupied periods and continuous during occupied periods. Always On mode operates the fan continuously during both occupied and unoccupied periods. In the default mode, Continuous, the fan will be turned on whenever any one of the following is true:

- The unit is in occupied mode as determined by its occupancy status.
- There is a demand for cooling or heating in the unoccupied mode.
- There is a call for dehumidification (optional).

When power is reapplied after a power outage, there will be a configured time delay of 5 to 600 seconds before starting the

fan. There are also configured fan delays for Fan On and Fan Off. The Fan On delay defines the delay time (0 to 30 seconds; default 10) before the fan begins to operate after heating or cooling is started while the Fan Off delay defines the delay time (0 to 180 seconds; default 45) the fan will continue to operate after heating or cooling is stopped. The fan will continue to run as long as the compressors, heating stages, or the dehumidification relays are on. If the SPT failure alarm or condensate overflow alarm is active; the fan will be shut down immediately regardless of occupancy state or demand.

Fan Speed Control (During Heating) — Whenever heat is required and active, the control continuously monitors the supply-air temperature to verify it does not rise above the configured maximum heating SAT limit (110 F default). As the SAT approaches this value, the control will increase the fan speed as required to ensure the SAT will remain within the limit. This feature provides the most quiet and efficient operation by operating the fan at the lowest speed possible.

Fan Speed Control (During Cooling) — Whenever mechanical cooling is required and active, the control continuously monitors the supply-air temperature to verify it does not fall below the configured minimum cooling SAT limit (50 F default). As the SAT approaches this value, the control will increase the fan speed as required to ensure the SAT will remain within the limit. The fan will operate at lowest speed to maximize latent capacity during cooling.

COOLING — The WSHP Open controller will operate one or two stages of compression to maintain the desired cooling set point. The compressor outputs are controlled by the PI (proportional-integral) cooling loop and cooling stages capacity algorithm. They will be used to calculate the desired number of stages needed to satisfy the space by comparing the space temperature (SPT) to the appropriate cooling set point. The water side economizer, if applicable, will be used for first stage cooling in addition to the compressor(s). The following conditions must be true in order for the cooling algorithm to run:

- Cooling is set to Enable.
- Heating mode is not active and the compressor time guard has expired.
- Condensate overflow input is normal.
- If occupied, the SPT is greater than the occupied cooling set point.
- Space temperature reading is valid.
- If unoccupied, the SPT is greater than the unoccupied cooling set point.
- If economizer cooling is available and active and the economizer alone is insufficient to provide enough cooling.
- OAT (if available) is greater than the cooling lockout temperature.

If all the above conditions are met, the compressors will be energized as required, otherwise they will be deenergized. If cooling is active and should the SAT approach the minimum SAT limit, the fan will be indexed to the next higher speed. Should this be insufficient and if the SAT falls further (equal to the minimum SAT limit), the fan will be indexed to the maximum speed. If the SAT continues to fall 5° F below the minimum SAT limit, all cooling stages will be disabled.

During Cooling mode, the reversing valve output will be held in the cooling position (either B or O type as configured) even after the compressor is stopped. The valve will not switch position until the Heating mode is required.

The configuration screens contain the minimum SAT parameter as well as cooling lockout based on outdoor-air temperature (OAT) Both can be adjusted to meet various specifications.

There is a 5-minute off time for the compressor as well as a 5-minute time delay when staging up to allow the SAT to achieve a stable temperature before energizing a second stage

of capacity. Likewise, a 45-second delay is used when staging down.

After a compressor is staged off, it may be restarted again after a normal time-guard period of 5 minutes and if the supply-air temperature has increased above the minimum supply-air temperature limit.

The WSHP Open controller provides a status input to monitor the compressor operation. The status is monitored to determine if the compressor status matches the commanded state. This input is used to determine if a refrigerant safety switch or other safety device has tripped and caused the compressor to stop operating normally. If this should occur, an alarm will be generated to indicate the faulted compressor condition.

HEATING — The WSHP Open controller will operate one or two stages of compression to maintain the desired heating set point. The compressor outputs are controlled by the heating PI (proportional-integral) loop and heating stages capacity algorithm. They will be used to calculate the desired number of stages needed to satisfy the space by comparing the space temperature (SPT) to the appropriate heating set point. The following conditions must be true in order for the heating algorithm to run:

- Heating is set to Enable.
- Cooling mode is not active and the compressor time guard has expired.
- Condensate overflow input is normal.
- If occupied, the SPT is less than the occupied heating set point.
- Space temperature reading is valid.
- If unoccupied, the SPT is less than the unoccupied heating set point.
- OAT (if available) is less than the heating lockout temperature.

If all the above conditions are met, the heating outputs will be energized as required, otherwise they will be deenergized. If the heating is active and should the SAT approach the maximum SAT limit, the fan will be indexed to the next higher speed. Should this be insufficient, and the SAT rises further reaching the maximum heating SAT limit, the fan will be indexed to the maximum speed. If the SAT still continues to rise 5° F above the maximum limit, all heating stages will be disabled.

During Heating mode, the reversing valve output will be held in the heating position (either B or O type as configured) even after the compressor is stopped. The valve will not switch position until the Cooling mode is required.

The configuration screens contain the maximum SAT parameter as well as heating lockout based on outdoor-air temperature (OAT); both can be adjusted to meet various specifications.

There is a 5-minute off time for the compressor as well as a 5-minute time delay when staging up to allow the SAT to achieve a stable temperature before energizing a second stage of capacity. Likewise, a 45-second delay is used when staging down.

After a compressor is staged off, it may be restarted again after a normal time-guard period of 5 minutes and if the supply-air temperature has fallen below the maximum supply air temperature limit.

The WSHP Open controller provides a status input to monitor the compressor operation. The status is monitored to determine if the compressor status matches the commanded state. This input is used to determine if a refrigerant safety switch or other safety device has tripped and caused the compressor to stop operating normally. If this should occur, an alarm will be generated to indicate the faulted compressor condition. Also, if auxiliary heat is available (see below), the auxiliary heat will operate to replace the reverse cycle heating and maintain the space temperature as required.

AUXILIARY HEAT — The WSHP Open controller can control a two-position, modulating water, or steam valve connected to a coil on the discharge side of the unit and supplied by a boiler or a single-stage ducted electric heater in order to maintain the desired heating set point. Should the compressor capacity be insufficient or a compressor failure occurs, the auxiliary heat will be used. Unless the compressor fails, the auxiliary heat will only operate to supplement the heat provided by the compressor if the space temperature falls more than one degree below the desired heating set point (the amount is configurable). The heat will be controlled so the SAT will not exceed the maximum heating SAT limit.

Auxiliary Modulating Hot Water/Steam Heating Reheat — The control can modulate a hot water or steam valve connected to a coil on the discharge side of the unit and supplied by a boiler in order to maintain the desired heating set point should the compressor capacity be insufficient or a compressor failure occurs. Unless a compressor fault condition exists, the valve will only operate to supplement heat provided by compressor if the space temperature falls more than one degree below the desired heating set point. The valve will be controlled so the SAT will not exceed maximum heating SAT limit.

Two-Position Hot Water/Steam Heating Reheat — The control can operate a two-position, NO or NC, hot water or steam valve connected to a coil on the discharge side of the unit and supplied by a boiler in order to maintain the desired heating set point should the compressor capacity be insufficient or a compressor failure occurs. Unless a compressor fault condition exists, the valve will only open to supplement the heat provided by the compressor if the space temperature falls more than one degree below the desired heating set point. The valve will be controlled so the SAT will not exceed the maximum heating SAT limit. The heat stage will also be subject to a 2-minute minimum OFF time to prevent excessive valve cycling.

Single Stage Electric Auxiliary Heat — The control can operate a field-installed single stage of electric heat installed on the discharge side of the unit in order to maintain the desired heating set point should the compressor capacity be insufficient or a compressor failure occurs. Unless a compressor fault condition exists, the heat stage will only operate to supplement the heat provided by the compressor if the space temperature falls more than one degree below the desired heating set point. The heat stage will be controlled so the SAT will not exceed the maximum heating SAT limit. The heat stage will also be subject to a 2-minute minimum OFF time to prevent excessive cycling.

INDOOR AIR QUALITY (IAQ) AND DEMAND CONTROLLED VENTILATION (DCV) — If the optional indoor air quality sensor is installed, the WSHP Open controller can maintain indoor air quality via a modulating OA damper providing demand controlled ventilation. The control operates the modulating OA damper during occupied periods. The control monitors the CO₂ level and compares it to the configured set points, adjusting the ventilation rate as required. The control provides proportional ventilation to meet the requirements of ASHRAE (American Society of Heating, Refrigerating and Air Conditioning Engineers) specifications by providing a base ventilation rate and then increasing the rate as the CO₂ level increases. The control will begin to proportionally increase ventilation when the CO₂ level rises above the start ventilation set point and will reach the full ventilation rate when the CO₂ level is at or above the maximum set point. A user-configurable minimum damper position ensures that proper base ventilation is delivered when occupants are not present. The IAQ configurations can be accessed through the configuration screen. The following conditions must be true in order for this algorithm to run:

- Damper control is configured for DCV.
- The unit is in an occupied mode.

- The IAQ sensor reading is greater than the DCV start control set point.

The control has four user adjustable set points: DCV start control set point, DCV maximum control set point, minimum damper position, and DCV maximum damper position.

Two-Position OA Damper — The control can be configured to operate a ventilation damper in a two-position ventilation mode to provide the minimum ventilation requirements during occupied periods.

WATERSIDE ECONOMIZER — The WSHP Open controller has the capability of providing modulating or two-position water economizer operation (for a field-installed economizer coil mounted to the entering air side of the unit and connected to the condenser water loop) in order to provide free cooling (or preheating) when water conditions are optimal. Water economizer settings can be accessed through the equipment status screen. The following conditions must be true for economizer operation:

- SAT reading is available.
- LWT reading is available.
- If occupied, the SPT is greater than the occupied cooling set point or less than the occupied heating set point and the condenser water is suitable.
- Space temperature reading is valid.
- If unoccupied, the SPT is greater than the unoccupied cooling set point or less than the unoccupied heating set point and the condenser water is suitable.

Modulating Water Economizer Control — The control has the capability to modulate a water valve to control condenser water flowing through a coil on the entering air side of the unit.

Cooling — The purpose is to provide an economizer cooling function by using the water loop when the entering water loop temperature is suitable (at least 5° F below space temperature). If the water loop conditions are suitable, then the valve will modulate open as required to maintain a supply-air temperature that meets the load conditions. Should the economizer coil capacity alone be insufficient for a period greater than 5 minutes, or should a high humidity condition occur, then the compressor will also be started to satisfy the load. Should the SAT approach the minimum cooling SAT limit, the economizer valve will modulate closed during compressor operation.

Heating — Additionally, the control will modulate the water valve should the entering water loop temperature be suitable for heating (at least 5° F above space temperature) and heat is required. The valve will be controlled in a similar manner except to satisfy the heating requirement. Should the economizer coil capacity alone be insufficient to satisfy the space load conditions for more than 5 minutes, then the compressor will be started to satisfy the load. Should the SAT approach the maximum heating SAT limit, the economizer valve will modulate closed during compressor operation.

Two-Position Water Economizer Control — The control has the capability to control a NO or NC, two-position water valve to control condenser water flow through a coil on the entering air side of the unit.

Cooling — The purpose is to provide a cooling economizer function directly from the condenser water loop when the entering water loop temperature is suitable (at least 5° F below space temperature). If the optional coil is provided and the water loop conditions are suitable, then the valve will open to provide cooling to the space when required. Should the capacity be insufficient for a period greater than 5 minutes, or should a high humidity condition occur, then the compressor will be started to satisfy the load. Should the SAT reach the minimum cooling SAT limit, the economizer valve will close during compressor operation.

Heating — Additionally, the economizer control will open the water valve should the entering water loop temperature be suitable for heating (at least 5° F above space temperature) and

heat is required. The valve will be controlled in a similar manner except to satisfy the heating requirement. Should the coil capacity be insufficient to satisfy the space load for more than 5 minutes, then the compressor will be started to satisfy the load. Should the SAT reach the maximum heating SAT limit, the economizer valve will close during compressor operation.

DEMAND LIMIT — The WSHP Open controller has the ability to accept three levels of demand limit from the network. In response to a demand limit, the unit will decrease its heating set point and increase its cooling set point to widen the range in order to immediately lower the electrical demand. The amount of temperature adjustment in response is user adjustable for both heating and cooling and for each demand level. The response to a particular demand level may also be set to zero.

CONDENSER WATER LINKAGE — The control provides optimized water loop operation using an universal controller (UC) open loop controller. Loop pump operation is automatically controlled by WSHP equipment occupancy schedules, unoccupied demand and tenant override conditions. Positive pump status feedback prevents nuisance fault trips. The condenser water linkage operates when a request for condenser water pump operation is sent from each WSHP to the loop controller. This request is generated whenever any WSHP is scheduled to be occupied, is starting during optimal start (for warm-up or pull down prior to occupancy), there is an unoccupied heating or cooling demand, or a tenant pushbutton override. At each WSHP, the water loop temperature and the loop pump status is given. The WSHP will NOT start a compressor until the loop pumps are running or will shutdown the compressors should the pumps stop. This prevents the WSHP from operating without water flow and thus tripping out on refrigerant pressure, causing a lockout condition. The WSHP Open controller control will prevent this from occurring. Also, the loop controller can be configured to start the pumps only after a configurable number of WSHPs are requesting operation (from 1-"N"). This can be used to prevent starting the entire loop operation for only one WSHP. Meanwhile, the WSHPs will not operate if the loop pump status is off and therefore the WSHP compressor will not run.

COMPLETE C AND DELUXE D BOARD SYSTEM TEST

System testing provides the ability to check the control operation. The control enters a 20-minute Test mode by momentarily shorting the test pins. All time delays are increased 15 times. See Fig. 13-17.

Test Mode — To enter Test mode on Complete C or Deluxe D controls, cycle the fan 3 times within 60 seconds. The LED (light-emitting diode) will flash a code representing the last fault when entering the Test mode. The alarm relay will also power on and off during Test mode. See Tables 29-31. To exit Test mode, short the terminals for 3 seconds or cycle the fan 3 times within 60 seconds.

NOTE: Deluxe D control has a flashing code and alarm relay cycling code that will both have the same numerical label. For example, flashing code 1 will have an alarm relay cycling code 1. Code 1 indicates the control has not faulted since the last power off to power on sequence.

WSHP Open Test Mode — To enter WSHP Open test mode, navigate from the BACview⁶ home screen to the configuration screen. Choose the service screen and enable unit test. The controller will then test the following:

FAN TEST — Tests all fan speeds, sequences fan from low to high, and operates each speed for one minute. Resets to disable on completion.

COMPRESSOR TEST — Tests compressor cooling and heating operation. Sequences cooling stage 1 then cooling

stage 2 followed by heating stage 2 then reduces capacity to heating stage 1. Operates for 1 minute per step.

DEHUMIDIFICATION TEST — Tests dehumidification mode. Operates for 2 minutes.

AUXILIARY HEATING TEST — Tests auxiliary heat. Sequences fan on and enables heating coil for 1 minute.

H₂O ECONOMIZER TEST — Tests entering/returning water loop economizer operation. Sequences fan and opens economizer water valve for one minute.

OPEN VENT DAMPER 100% TEST — Tests outside air (OA) damper operation.

PREPOSITION OA DAMPER — Prepositions OA damper actuator to set proper preload.

NOTE: The auxiliary heating test, H₂O economizer test, open vent damper 100% test, and preposition OA damper features will not be visible on the screen unless configured.

Once tests are complete, set unit test back to disable. Unit will automatically reset to disable after 1 hour.

Retry Mode — In Retry mode, the status LED will start to flash slowly to signal that the control is trying to recover from an input fault. The control will stage off the outputs and try to again satisfy the thermostat used to terminal Y. Once the thermostat input calls are satisfied, the control will continue normal operation.

NOTE: If 3 consecutive faults occur without satisfying the thermostat input call to terminal Y, the control will go into lockout mode. The last fault causing the lockout is stored in memory and can be viewed by entering Test mode.

Aquazone™ Deluxe D Control LED Indicators — There are 3 LED indicators on the Deluxe D control:

STATUS LED — Status LED indicates the current status or mode of the Deluxe D control. The Status LED light is green.

TEST LED — Test LED will be activated any time the Deluxe D control is in test mode. The Test LED light is yellow.

FAULT LED — Fault LED light is red. The fault LED will always flash a code representing the last fault in memory. If there is no fault in memory, the fault LED will flash code 1 on the and appear as 1 fast flash alternating with a 10-second pause. See Table 31.

Table 29 — Complete C Control Current LED Status and Alarm Relay Operations

LED STATUS	DESCRIPTION OF OPERATION	ALARM RELAY
On	Normal Mode	Open
	Normal Mode with PM Warning	Cycle (closed 5 sec., Open 25 sec.)
Off	Complete C Control is non-functional	Open
Slow Flash	Fault Retry	Open
Fast Flash	Lockout	Closed
Slow Flash	Over/Under Voltage Shutdown	Open (Closed after 15 minutes)
Flashing Code 1	Test Mode — No fault in memory	Cycling Code 1
Flashing Code 2	Test Mode — HP Fault in memory	Cycling Code 2
Flashing Code 3	Test Mode — LP Fault in memory	Cycling Code 3
Flashing Code 4	Test Mode — FP1 Fault in memory	Cycling Code 4
Flashing Code 5	Test Mode — FP2 Fault in memory	Cycling Code 5
Flashing Code 6	Test Mode — CO Fault in memory	Cycling Code 6
Flashing Code 7	Test Mode — Over/Under shutdown in memory	Cycling Code 7
Flashing Code 8	Test Mode — PM in memory	Cycling Code 8
Flashing Code 9	Test Mode — FP1/FP2 Swapped Fault in memory	Cycling Code 9

LEGEND

CO — Condensate Overflow **LED** — Light-Emitting Diode
FP — Freeze Protection **LP** — Low Pressure
HP — High Pressure **PM** — Performance Monitor

NOTES:

- Slow flash is 1 flash every 2 seconds.
- Fast flash is 2 flashes every 1 second.
- EXAMPLE: "Flashing Code 2" is represented by 2 fast flashes followed by a 10-second pause. This sequence will repeat continually until the fault is cleared.

Table 30 — Complete C Control LED Code and Fault Descriptions

LED CODE	FAULT	DESCRIPTION
1	No fault in memory	There has been no fault since the last power-down to power-up sequence
2	High-Pressure Switch	HP open instantly
3	Low-Pressure Switch	LP open for 30 continuous seconds before or during a call (bypassed for first 60 seconds)
4	Freeze Protection Coax — FP1	FP1 below Temp limit for 30 continuous seconds (bypassed for first 60 seconds of operation)
5	Freeze Protection Air Coil — FP2	FP2 below Temp limit for 30 continuous seconds (bypassed for first 60 seconds of operation)
6	Condensate overflow	Sense overflow (grounded) for 30 continuous seconds
7 (Autoreset)	Over/Under Voltage Shutdown	"R" power supply is <19VAC or >30VAC
8	PM Warning	Performance Monitor Warning has occurred.
9	FP1 and FP2 Thermistors are swapped	FP1 temperature is higher than FP2 in heating/test mode, or FP2 temperature is higher than FP1 in cooling/test mode.

LEGEND

FP — Freeze Protection **LP** — Low Pressure
HP — High Pressure **PM** — Performance Monitor
LED — Light-Emitting Diode

Table 31 — Aquazone Deluxe D Control Current LED Status and Alarm Relay Operations

DESCRIPTION	STATUS LED (Green)	TEST LED (Yellow)	FAULT LED (Red)	ALARM RELAY
Normal Mode	On	Off	Flash Last Fault Code in Memory	Open
Normal Mode with PM	On	Off	Flashing Code 8	Cycle (closed 5 sec, open 25 sec, ...)
Deluxe D Control is non-functional	Off	Off	Off	Open
Test Mode	—	On	Flash Last Fault Code in Memory	Cycling Appropriate Code
Night Setback	Flashing Code 2	—	Flash Last Fault Code in Memory	—
ESD	Flashing Code 3	—	Flash Last Fault Code in Memory	—
Invalid T-stat Inputs	Flashing Code 4	—	Flash Last Fault Code in Memory	—
No Fault in Memory	On	Off	Flashing Code 1	Open
HP Fault	Slow Flash	Off	Flashing Code 2	Open
LP Fault	Slow Flash	Off	Flashing Code 3	Open
FP1 Fault	Slow Flash	Off	Flashing Code 4	Open
FP2 Fault	Slow Flash	Off	Flashing Code 5	Open
CO Fault	Slow Flash	Off	Flashing Code 6	Open
Over/Under Voltage	Slow Flash	Off	Flashing Code 7	Open (closed after 15 minutes)
HP Lockout	Fast Flash	Off	Flashing Code 2	Closed
LP Lockout	Fast Flash	Off	Flashing Code 3	Closed
FP1 Lockout	Fast Flash	Off	Flashing Code 4	Closed
FP2 Lockout	Fast Flash	Off	Flashing Code 5	Closed
CO Lockout	Fast Flash	Off	Flashing Code 6	Closed

LEGEND

- | | |
|--------------------------|--------------------------|
| CO — Condensate Overflow | HP — High Pressure |
| ESD — Emergency Shutdown | LP — Low Pressure |
| FP — Freeze Protection | PM — Performance Monitor |

NOTES:

1. If there is no fault in memory, the Fault LED will flash code 1.
2. Codes will be displayed with a 10-second Fault LED pause.
3. Slow flash is 1 flash every 2 seconds.
4. Fast flash is 2 flashes every 1 second.
5. EXAMPLE: "Flashing Code 2" is represented by 2 fast flashes followed by a 10-second pause. This sequence will repeat continually until the fault is cleared.

SERVICE

Perform the procedures outlined below periodically, as indicated.

IMPORTANT: When a compressor is removed from this unit, system refrigerant circuit oil will remain in the compressor. To avoid leakage of compressor oil, the refrigerant lines of the compressor must be sealed after it is removed.

IMPORTANT: All refrigerant discharged from this unit must be recovered without exception. Technicians must follow industry accepted guidelines and all local, state and federal statutes for the recovery and disposal of refrigerants.

IMPORTANT: To avoid the release of refrigerant into the atmosphere, the refrigerant circuit of this unit must only be serviced by technicians who meet local, state and federal proficiency requirements.

IMPORTANT: To prevent injury or death due to electrical shock or contact with moving parts, open unit disconnect switch before servicing unit.

Filters — Filters must be clean for maximum performance. Inspect filters every month under normal operating conditions. Replace when necessary.

IMPORTANT: Units should never be operated without a filter.

Water Coil — Keep all air out of the water coil. Check open loop systems to be sure the well head is not allowing air to infiltrate the water line. Always keep lines airtight.

Inspect heat exchangers regularly, and clean more frequently if the unit is located in a "dirty" environment. Keep the heat exchanger full of water at all times. Open-loop systems should have an inverted P trap placed in the discharge line to keep water in the heat exchanger during off cycles.

Closed-loop systems must have a minimum of 15 psig during the summer and 40 psig during the winter. Generally, the higher the water flow through the bail, the lower the chance for sealing.

Check P trap frequently for proper operation.

IMPORTANT: To avoid fouled machinery and extensive unit clean-up, DO NOT operate units without filters in place. DO NOT use equipment as a temporary heat source during construction.

Condensate Drain Pans — Check condensate drain pans for algae growth twice a year. If algae growth is apparent, consult a water treatment specialist for proper chemical treatment. Applying an algicide every three months will typically eliminate algae problems in most locations.

Refrigerant System — Verify air and water flow rates are at proper levels before servicing. To maintain sealed circuitry integrity, do not install service gauges unless unit operation appears abnormal.

Check to see that unit is within the superheat and subcooling temperature ranges shown in Tables 16-26. If the unit is not within these ranges, recover and reweigh in refrigerant charge.

Compressor — Conduct annual amperage checks to ensure that amp draw is no more than 10% greater than indicated on the serial plate data.

Fan Motors — All units have lubricated fan motors. Fan motors should never be lubricated unless obvious, dry operation is suspected. Periodic maintenance oiling is NOT recommended as it will result in dirt accumulating in the excess oil and cause eventual motor failure. Conduct annual dry operation check and amperage check to ensure amp draw is no more than 10% greater than indicated on serial plate data.

Condensate Drain Cleaning — Clean the drain line and unit drain pan at the start of each cooling season. Check flow by pouring water into drain. Be sure trap is filled to maintain an air seal.

Air Coil Cleaning — Remove dirt and debris from evaporator coil as required by condition of the coil. A 10% solution of dishwasher detergent and water is recommended for cleaning both sides of the coil, followed by a thorough water rinse. Clean coil with a stiff brush, vacuum cleaner, or compressed air. Use a fin comb of the correct tooth spacing when straightening mashed or bent coil fins.

Condenser Cleaning — Water-cooled condensers may require cleaning of scale (water deposits) due to improperly maintained closed-loop water systems. Sludge build-up may need to be cleaned in an open water tower system due to induced contaminants.

Local water conditions may cause excessive fouling or pitting of tubes. Condenser tubes should therefore be cleaned at least once a year, or more often if the water is contaminated.

Proper water treatment can minimize tube fouling and pitting. If such conditions are anticipated, water treatment analysis is recommended. Refer to the Carrier System Design Manual, Part 5, for general water conditioning information.

⚠ CAUTION

Follow all safety codes. Wear safety glasses and rubber gloves when using inhibited hydrochloric acid solution. Observe and follow acid manufacturer's instructions.

Clean condensers with an inhibited hydrochloric acid solution. The acid can stain hands and clothing, damage concrete, and, without inhibitor, damage steel. Cover surroundings to guard against splashing. Vapors from vent pipe are not harmful, but take care to prevent liquid from being carried over by the gases.

Warm solution acts faster, but cold solution is just as effective if applied for a longer period.

GRAVITY FLOW METHOD — Do not add solution faster than vent can exhaust the generated gases.

When condenser is full, allow solution to remain overnight, then drain condenser and flush with clean water. Follow acid manufacturer's instructions. See Fig. 30.

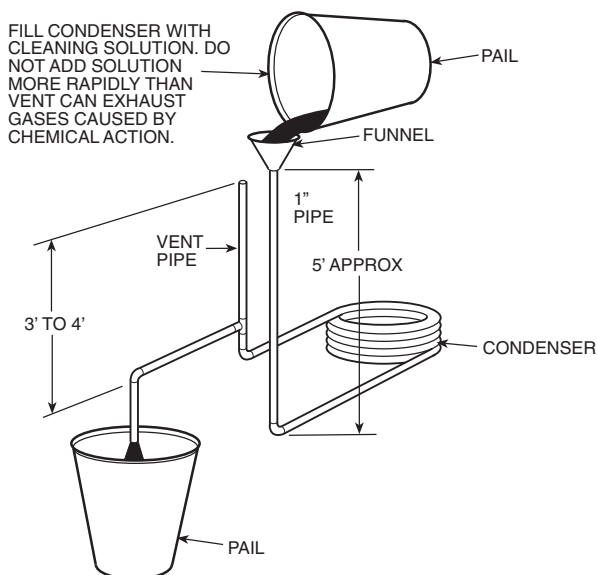

Fig. 30 — Gravity Flow Method

FORCED CIRCULATION METHOD — Fully open vent pipe when filling condenser. The vent may be closed when condenser is full and pump is operating. See Fig. 31.

Regulate flow to condenser with a supply line valve. If pump is a nonoverloading type, the valve may be fully closed while pump is running.

For average scale deposit, allow solution to remain in condenser overnight. For heavy scale deposit, allow 24 hours. Drain condenser and flush with clean water. Follow acid manufacturer's instructions.

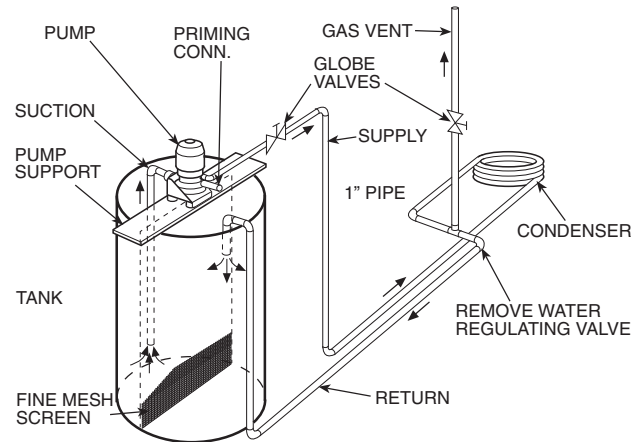

Fig. 31 — Forced Circulation Method

Checking System Charge — Units are shipped with full operating charge. If recharging is necessary:

1. Insert thermometer bulb in insulating rubber sleeve on liquid line near filter drier. Use a digital thermometer for all temperature measurements. DO NOT use a mercury or dial-type thermometer.
2. Connect pressure gage to discharge line near compressor.
3. After unit conditions have stabilized, read head pressure on discharge line gage.

NOTE: Operate unit a minimum of 15 minutes before checking charge.

4. From standard field-supplied Pressure-Temperature chart for R-410A, find equivalent saturated condensing temperature.
5. Read liquid line temperature on thermometer; then subtract from saturated condensing temperature. The difference equals subcooling temperature.
6. Compare the subcooling temperature with the normal temperature listed in Tables 15-25. If the measured liquid line temperature does not agree with the required liquid line temperature, ADD refrigerant to raise the temperature or REMOVE refrigerant (using standard practices) to lower the temperature (allow a tolerance of $\pm 3^\circ \text{F}$).

Refrigerant Charging

⚠ WARNING

To prevent personal injury, wear safety glasses and gloves when handling refrigerant. Do not overcharge system — this can cause compressor flooding.

NOTE: Do not vent or depressurize unit refrigerant to atmosphere. Remove and recover refrigerant following accepted practices.

Air Coil Fan Motor Removal

CAUTION

Before attempting to remove fan motors or motor mounts, place a piece of plywood over evaporator coils to prevent coil damage.

Disconnect motor power wires from motor terminals before motor is removed from unit.

1. Shut off unit main power supply.
2. Loosen bolts on mounting bracket so that fan belt can be removed.
3. Loosen and remove the 2 motor mounting bracket bolts on left side of bracket.
4. Slide motor/bracket assembly to extreme right and lift out through space between fan scroll and side frame. Rest motor on a high platform such as a step ladder. Do not allow motor to hang by its power wires.

Replacing the WSHP Open Controller's Battery

The WSHP Open controller's 10-year lithium CR2032 battery provides a minimum of 10,000 hours of data retention during power outages.

NOTE: Power must be ON to the WSHP Open controller when replacing the battery, or the date, time and trend data will be lost.

1. Remove the battery from the controller, making note of the battery's polarity.
2. Insert the new battery, matching the battery's polarity with the polarity indicated on the WSHP Open controller.

TROUBLESHOOTING (Fig. 32 and 33, and Table 32)

When troubleshooting problems with a WSHP, consider the following.

Thermistor — A thermistor may be required for single-phase units where starting the unit is a problem due to low voltage. See Fig. 32 for thermistor nominal resistance.

Control Sensors — The control system employs 2 nominal 10,000 ohm thermistors (FP1 and FP2) that are used for freeze protection. Be sure FP1 is located in the discharge fluid and FP2 is located in the air discharge. See Fig. 33.

WSHP Open Controller — With the WSHP Open controller option, the 100 most recent alarms can be viewed using the BACview⁶ alarm status and alarm history.

To view the alarms:

1. Navigate to the Alarm Status screen from the Home screen using the arrow softkeys. The screen will display the current alarm status, either normal or Alarm, and allow for scrolling through the unit's alarm status.
2. From the Alarm Status screen, press the Alarm softkey to view the 100 most recent alarms which are labeled with date and time for easy reference.

NOTE: Active faults can be viewed by scrolling down, these faults indicate a possible bad sensor or some condition which may not merit an alarm.

3. To view alarms which have been corrected, scroll down through the Alarm screen to Return Top Normal screen.

NOTE: Alarms are automatically reset once alarm condition has been corrected.

See Table 32 for possible alarm cause and solution.

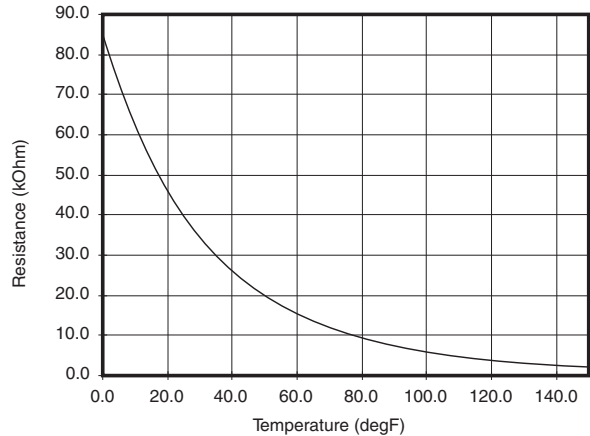

Fig. 32 — Thermistor Nominal Resistance

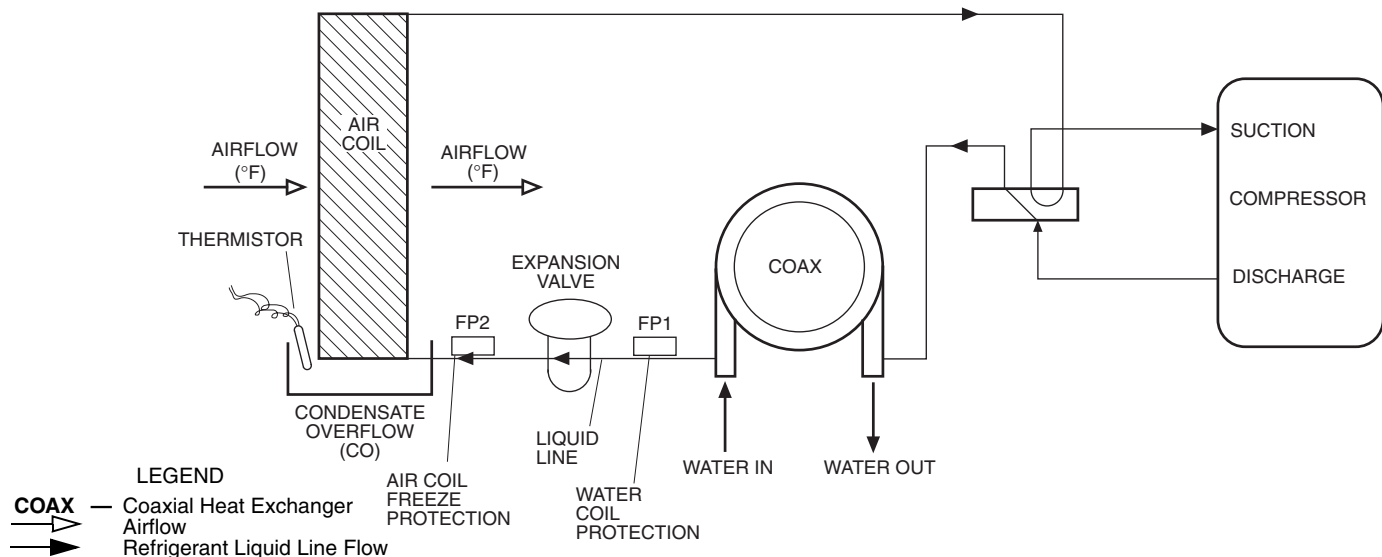

Fig. 33 — FP1 and FP2 Thermistor Location

Table 32 — Troubleshooting

FAULT	HEATING	COOLING	POSSIBLE CAUSE	SOLUTION	
Main Power Problems	X	X	Green Status LED Off	Check line voltage circuit breaker and disconnect.	
				Check for line voltage between L1 and L2 on the contactor.	
				Check for 24 vac between R and C on controller.	
				Check primary/secondary voltage on transformer.	
HP Fault — Code 2 High Pressure		X	Reduced or no water flow in cooling	Check pump operation or valve operation/setting. Check water flow adjust to proper flow rate.	
		X	Water temperature out of range in cooling	Bring water temperature within design parameters.	
	X		Reduced or no airflow in heating	Check for dirty air filter and clean or replace. Check fan motor operation and airflow restrictions. Dirty air coil — construction dust etc. External static too high. Check Tables 8-10.	
	X		Air temperature out of range in heating	Bring return-air temperature within design parameters.	
	X	X	Overcharged with refrigerant	Check superheat/subcooling vs typical operating condition Tables 15-25.	
	X	X	Bad HP switch	Check switch continuity and operation. Replace.	
LP/LOC Fault — Code 3 Low Pressure/Loss of Charge	X	X	Insufficient charge	Check for refrigerant leaks.	
	X		Compressor pump down at start-up	Check charge and start-up water flow.	
FP1 Fault — Code 4 Water Freeze Protection	X		Reduced or no water flow in heating	Check pump operation or water valve operation/setting. Plugged strainer or filter. Clean or replace. Check water flow adjust to proper flow rate.	
		X	Inadequate antifreeze level	Check antifreeze density with hydrometer.	
		X	Improper freeze protect setting (30 F vs 10 F)	Clip JW2 jumper for antifreeze (10 F) use.	
	X		Water temperature out of range	Bring water temperature within design parameters.	
	X	X	Bad thermistor	Check temperature and impedance correlation.	
FP2 Fault — Code 5 Air Coil Freeze Protection		X	Reduced or no airflow in cooling	Check for dirty air filter and clean or replace. Check fan motor operation and airflow restrictions. External static too high. Check Tables 8-10.	
		X	Air temperature out of range	Too much cold vent air. Bring entering-air temperature within design parameters.	
		X	Improper freeze protect setting (30 F vs 10 F)	Normal airside applications will require 30 F only.	
	X	X	Bad thermistor	Check temperature and impedance correlation.	
Condensate Fault — Code 6	X	X	Blocked drain	Check for blockage and clean drain.	
	X	X	Improper trap	Check trap dimensions and location ahead of vent.	
		X	Poor drainage	Check for piping slope away from unit. Check slope of unit toward outlet. Poor venting. Check vent location.	
		X	Moisture on sensor	Check for moisture shorting to air coil.	
Over/Under Voltage — Code 7 (Auto Resetting)	X	X	Under voltage	Check power supply and 24 vac voltage before and during operation. Check power supply wire size. Check compressor starting. Check 24 vac and unit transformer tap for correct power supply voltage.	
				Over voltage	Check power supply voltage and 24 vac before and during operation. Check 24 vac and unit transformer tap for correct power supply voltage.
Performance Monitor — Code 8	X		Heating mode FP2>125 F	Check for poor airflow or overcharged unit.	
		X	Cooling mode FP1>125 F OR FP2< 40 F	Check for poor water flow or airflow.	
FP1 and FP2 Thermistors — Code 9	X		FP1 temperature is higher than FP2 temperature.	Swap FP1 and FP2 thermistors.	
		X	FP2 temperature is higher than FP1 temperature.	Swap FP1 and FP2 thermistors.	
No Fault Code Shown	X	X	No compressor operation	See scroll compressor rotation section on page 28.	
	X	X	Compressor overload	Check and replace if necessary.	
	X	X	Control board	Reset power and check operation.	
Unit Short Cycles	X	X	Dirty air filter	Check and clean air filter.	
	X	X	Unit in 'Test Mode'	Reset power or wait 20 minutes for auto exit.	
	X	X	Unit selection	Unit may be oversized for space. Check sizing for actual load of space.	
	X	X	Compressor overload	Check and replace if necessary.	
Only Fan Runs	X	X	Thermostat position	Ensure thermostat set for heating or cooling operation.	
	X	X	Unit locked out	Check for lockout codes. Reset power.	
	X	X	Compressor overload	Check compressor overload. Replace if necessary.	
	X	X	Thermostat wiring	Check Y and W wiring at heat pump. Jumper Y and R for compressor operation in Test mode.	

LEGEND
RV — Reversing Valve

Table 32 — Troubleshooting (cont)

FAULT	HEATING	COOLING	POSSIBLE CAUSE	SOLUTION
Only Compressor Runs	X	X	Thermostat wiring	Check G wiring at heat pump. Jumper G and R for fan operation. Check Y and W wiring at heat pump. Jumper Y and R for compressor operation in test mode.
	X	X	Fan motor relay	Jumper G and R for fan operation. Check for line voltage across BR contacts. Check fan power enable relay operation (if present).
	X	X	Fan motor	Check for line voltage at motor. Check capacitor.
Unit Does Not Operate in Cooling		X	Reversing valve	Set for cooling demand and check 24 VAC on RV coil and at control. If RV is stuck, run high pressure up by reducing water flow and while operating engage and disengage RV coil voltage to push valve.
		X	Thermostat setup	Check for 'O' RV setup not 'B'.
		X	Thermostat wiring	Check O wiring at heat pump. Check RV to ensure the valve is changing over from heating and cooling modes. A 'click' should be heard when the RV changes modes.
Insufficient Capacity/ Not Cooling or Heating Properly	X	X	Dirty filter	Replace or clean.
	X		Reduced or no airflow in heating	Check for dirty air filter and clean or replace.
				Check fan motor operation and airflow restrictions.
				External static too high. Check blower Tables 8-10.
		X	Reduced or no airflow in cooling	Check for dirty air filter and clean or replace.
				Check fan motor operation and airflow restrictions.
				External static too high. Check blower Tables 8-10.
	X	X	Leaky ductwork	Check supply and return-air temperatures at the unit and at distant duct registers if significantly different, duct leaks are present.
	X	X	Low refrigerant charge	Check superheat and subcooling Tables 15-25.
	X	X	Restricted metering device	Check superheat and subcooling Tables 15-25. Replace.
		X	Defective reversing valve	Manually check the four-way valve to ensure all valves are operational.
X	X	Thermostat improperly located	Check location and for air drafts behind thermostat.	
X	X	Unit undersized	Recheck loads and sizing check sensible cooling load and heat pump capacity.	
X	X	Scaling in water heat exchanger	Check for scale (water deposits) and clean if necessary.	
X	X	Inlet water too hot or cold	Check load, loop sizing, loop backfill, ground moisture.	
High Head Pressure	X		Reduced or no airflow in heating	Check for dirty air filter and clean or replace.
				Check fan motor operation and airflow restrictions.
				External static too high. Check blower Tables 8-10.
		X	Reduced or no water flow in cooling	Check pump operation or valve operation/setting.
				Check water flow adjust to proper flow rate. See Table 14.
		X	Inlet water too hot	Check load, loop sizing, loop backfill, ground moisture.
	X		Air temperature out of range in heating	Bring return-air temperature within design parameters.
		X	Scaling in water heat exchanger	Check for scale (water deposits) and clean if necessary.
X	X	Unit overcharged	Check superheat and subcooling. Reweigh in charge.	
X	X	Non-condensables in system	Evacuate the refrigerant, recharge the system, and then weigh the new refrigerant charge.	
X	X	Restricted metering device	Check superheat and subcooling per Tables 15-25. Replace.	
Low Suction Pressure	X		Reduced water flow in heating	Check pump operation or water valve operation/setting.
				Plugged strainer or filter. Clean or replace.
				Check water flow adjust to proper flow rate.
	X		Water temperature out of range	Bring water temperature within design parameters.
		X	Reduced airflow in cooling	Check for dirty air filter and clean or replace.
		Check fan motor operation and airflow restrictions.		
		External static too high. Check blower Tables 8-10.		
	X	Air temperature out of range	Too much cold vent air. Bring entering air temperature within design parameters.	
X	X	Insufficient charge	Check for refrigerant leaks.	
Low Discharge Air Temperature in Heating	X		Too high airflow	Check blower Tables 8-10.
	X		Poor performance	See 'Insufficient Capacity'.
High Humidity		X	Too high airflow	Check blower Tables 8-10.
		X	Unit oversized	Recheck loads and sizing check sensible cooling load and heat pump capacity.

LEGEND

RV — Reversing Valve

APPENDIX A — WSHP OPEN SCREEN CONFIGURATION

SCREEN NAME	POINT NAME	PASSWORD LEVEL	EDITABLE	RANGE	DEFAULT	NOTES	
Equipment Status	Operating Mode	No Password Required		Off, Fan Only, Economize, Cooling, Heating, Cont Fan, Test, Start Delay, Dehumidify		Displays unit operating mode	
	SPT			° F		Displays SPT	
	SAT			° F		Displays SAT	
	Condenser Leaving Temperature			° F		Displays leaving condenser water temperature	
	Condenser Entering Temperature			° F		Displays entering condenser water temperature (Value will not update when compressor is operating)	
	Fan				Off/Low Speed/ Medium Speed High Speed/On		Displays fan speed status
	Compressor Capacity				0 - 100%		Displays compressor capacity
	Damper Position				0 - 100%		Displays current damper position (Viewable only if Ventilation DMP Type = 2 position or DCV)
	H ₂ O Economizer				0 - 100%		Displays position of economizer valve
	Auxiliary Heat				0 - 100%		Displays position of auxiliary reheat valve (Viewable only if Leaving Air Auxiliary Heat Type = 2 position, 1 stage Elect or Modulating)
	Space RH				0 - 100%		Displays space RH% (Viewable only if Humidity Sensor = Installed)
	Dehumidification				Inactive/Active		Displays if dehumidification is active (Viewable only if Factory Dehumidification Reheat = Installed)
IAQ CO ₂			0 - 9999 ppm		Displays the space CO ₂ level		
Alarm Status	SPT Alarm Status	No Password Required		Normal/Alarm		Displays current space temperature condition	
	Alarming SPT			° F		Displays the SPT that exceeded the alarm limit (when SPT alarm above is in Alarm)	
	SPT Alarm Limit			° F		Displays the SPT alarm limit that was exceeded; causing the alarm condition (when SPT alarm above is in Alarm)	
	SPT Sensor Alarm Status				Normal/Alarm		Displays the status of the Rnet SPT sensor - ALARM is displayed should the sensor fail to communicate with the control module
	IAQ Alarm Status				Normal/Alarm		Current IAQ/ventilation condition
	Compressor Alarm Status				Normal/Alarm		Current compressor condition
	SAT Alarm Status				Normal/Alarm		Current SAT condition
	Condensate Overflow Alarm Status				Normal/Alarm		Current status of the condensate drain (overflow switch)
	Condenser Water Temperature Alarm Status				Normal/Alarm		Current status of the condenser water
	Filter Alarm Status				Normal/Alarm		Current filter condition
	Space RH Alarm Status				Normal/Alarm		Current space RH condition
	OAT Alarm Status				Normal/Alarm		Current status of the OAT broadcast function
	Airside Linkage Status				Normal/Alarm		Current linkage status if enabled
	Condenser Water Linkage				Normal/Alarm		Current linkage status if enabled
Sensor Calibration	SAT	Admin Password level access only		° F		Display SAT	
	SAT Offset		X	-9.9 - 10.0 ° F	0 ° F	Used to correct sensor reading	
	Leaving Condenser Water Temperature			° F		Displays Leaving Condenser Water Temperature	
	Leaving CW Offset		X	-9.9 - 10.0 ° F	0 ° F	Used to correct sensor reading	
	Rnet Sensor Temperature			° F		Displays SPT	
	Rnet Offset		X	-9.9 - 10.0 ° F	0 ° F	Used to correct sensor reading	
	RH			%		Displays Space RH value	
	RH Sensor Offset		X	-15% - 15%	0 %	Used to correct sensor reading	

LEGEND

BAS	— Building Automation System
DCV	— Demand Controlled Ventilation
IAQ	— Indoor Air Quality
OAT	— Outdoor Air Temperature
RH	— Relative Humidity
SAT	— Supply Air Temperature
SPT	— Space Temperature
TPI	— Third Party Integration

APPENDIX A — WSH OPEN SCREEN CONFIGURATION (cont)

SCREEN NAME	POINT NAME	PASSWORD LEVEL	EDITABLE	RANGE	DEFAULT	NOTES		
Unit Maintenance	Operating Mode	No Password required		Off, Fan Only, Economize, Cooling, Heating, Cont Fan, Test, Start Delay, Dehumidify		Displays unit operating mode		
	Fan Operating Mode			Auto/Continuous/Always On		Displays how the fan is configured to operate		
	Occupancy Status				Unoccupied/Occupied		Displays the current occupancy status	
	Occupancy Control				Always Occupied/Local Schedule/BACnet Schedule/BAS Keypad/ Occupied Contact/Holiday Schedule/Override Schedule/Pushbutton Override/Unoccupied None		Displays the origin of the occupancy control	
	Outside Air Temperature				° F		Displays OAT (Viewable only if OAT is a network broadcast)	
	SPT				° F		Displays SPT	
	SPT Status				Normal/Above Limit/Below Limit/Sensor Failure		Displays the SPT status	
	SPT Sensor Status				Inactive/Connected		Displays the connection status of the Rnet sensor	
	Condensate Overflow				Normal/Alarm		Displays the status of the condensate overflow	
	Cooling Set Point				° F		Displays the actual set point being used for cooling control	
	Heating Set Point				° F		Displays the actual set point being used for heating control	
	Set Point Adjustment				° F		Displays the offset values from the Rnet user set point adjustment that is being applied to the configured set points	
	Auxiliary Heat Control Set Point				° F		Displays the calculated set point being used for auxiliary heating control	
	H ₂ O Economizer Control Set Point				° F		Displays the calculated set point being used for economizer control	
	Calculated IAQ/Ventilation Damper position				%		Displays the ventilation damper position calculated by the DCV control	
	Active Compressor Stages				0/1/2		Displays the actual number of compressor stages operating	
	SAT				° F		Displays SAT	
	Reset Filter Alarm				X	No/Yes		Used to reset the filter alarm timer after the filter has been cleaned or replaced
	Overflow Contact					Closed/Open		Displays the state of the condensate overflow switch contact
	Occupancy Contact					Closed/Open		Displays the state of the external/remote occupancy input switch contact
BAS/Keypad Override			X	Inactive/Occupied/Unoccupied	Inactive	Provides capability to force the equipment to operate in an occupied or unoccupied mode		
OAT Input				N/A / Network		Displays if an OAT value is being received from the Network		
System Settings	BACnet		X			See TPI		
	Keypad Configuration		X			Mapping		
	Password		X			Changes password		
	Network		X			See TPI		
	BACnet Time Master		X			See TPI		
	Clock Set		X			Changes clock/time setting		
Occupancy Maintenance	Override Schedules	No Password required		Inactive/Active Occupied		Used to display the active and inactive occupancy control inputs		
	Pushbutton Override			Inactive/Active Occupied				
	Keypad Override			Inactive/Active Occupied/Active Unoccupied				
	Schedules			Inactive/Active Occupied				
	Occupancy Contact			Inactive/Active Occupied				
	BAS on/off			Inactive/Active Occupied				
Schedule Configuration	Local Occupancy Schedules	User/Admin Password level access	X	Disable/Enable	Enable	Used to define which occupancy inputs are used to determine occupancy mode.		
	Local Holiday Schedules		X	Disable/Enable	Disable			
	Local Override Schedules		X	Disable/Enable	Disable			
	BACnet Occupancy Schedules		X	Disable/Enable	Disable			

LEGEND

BAS — Building Automation System
DCV — Demand Controlled Ventilation
IAQ — Indoor Air Quality
OAT — Outdoor Air Temperature
RH — Relative Humidity
SAT — Supply Air Temperature
SPT — Space Temperature
TPI — Third Party Integration

APPENDIX A — WSHP OPEN SCREEN CONFIGURATION (cont)

SCREEN NAME	POINT NAME	PASSWORD LEVEL	EDITABLE	RANGE	DEFAULT	NOTES
Configuration ↓ Set Points	Occupied Heating	User/Admin Password level access	X	40 - 90 ° F	72 ° F	Defines the Occupied Heating Set Point
	Occupied Cooling		X	55 - 99 ° F	76 ° F	Defines the Occupied Cooling Set Point
	Unoccupied Heating		X	40 - 90 ° F	55 ° F	Defines the Unoccupied Heating Set Point
	Unoccupied Cooling		X	55 - 99 ° F	90 ° F	Defines the Unoccupied Cooling Set Point
	Effective Heating Set Point		X	0 - 10 ° F		Takes into effect bias (maximum allowable set point deviation)
	Effective Cooling Set Point		X	0 - 10 ° F		Takes into effect bias (maximum allowable set point deviation)
	Optimal Start					Uses historical data to calculate ramp up time so as to be at set point at occupied/unoccupied time
	Occupied RH Set Point		X	0 - 100%	65%	Defines the control set point used during occupied periods (Viewable only if Humidity Sensor = Installed/ Determines when to start Dehumidification when occupied)
	Unoccupied RH Set Point		X	0 - 100%	90%	Defines the control set point used during unoccupied periods (Viewable only if Humidity Sensor = Installed/Determines when to start Dehumidification when unoccupied)
	DCV CTRL Start Set Point		X	0 - 9999 ppm	500 ppm	Defines the control set point used to start increasing ventilation during occupied periods (Viewable only if Ventilation DMP Type = DCV)
	DCV Max CTRL Set Point		X	0 - 9999 ppm	1050 ppm	Defines the control set point used to define where the ventilation will reach its maximum limit during occupied periods (Viewable only if Ventilation DMP Type = DCV/Used to determine DCV ending control point)
Configuration ↓ Schedule ↓ Weekly Schedule	Start Time	User/Admin Password level access	X	00:00 - 23:59	06:00	Defines the start time for an occupied period
	End Time		X	00:00 - 24:00	18:00	Defines the ending time of an occupied period
	Mon		X	No/Yes	Yes	Determines if this day is included in this schedule
	Tue		X	No/Yes	Yes	Determines if this day is included in this schedule
	Wed		X	No/Yes	Yes	Determines if this day is included in this schedule
	Thur		X	No/Yes	Yes	Determines if this day is included in this schedule
	Fri		X	No/Yes	Yes	Determines if this day is included in this schedule
	Sat		X	No/Yes	No	Determines if this day is included in this schedule
Sun	X	No/Yes	No	Determines if this day is included in this schedule		
Configuration ↓ Schedule ↓ Exception Schedules 1 - 12	Start Month	User/Admin Password level access	X	0 - 12	0	Defines the start month of this holiday schedule
	Start Day		X	0 - 31	0	Defines the start day of this holiday schedule
	Start Time		X	00:00 - 23:59	0:00	Determines the start time for this schedule
	End Month		X	0 - 12	0	Defines the month to end this holiday schedule
	End Day		X	0 - 31	0	Defines the day to end this holiday schedule
	End Time		X	00:00 - 24:00	0:00	Determines the time to end this schedule

LEGEND

BAS — Building Automation System
DCV — Demand Controlled Ventilation
IAQ — Indoor Air Quality
OAT — Outdoor Air Temperature
RH — Relative Humidity
SAT — Supply Air Temperature
SPT — Space Temperature
TPI — Third Party Integration

APPENDIX A — WSHP SCREEN OPEN CONFIGURATION (cont)

SCREEN NAME	POINT NAME	PASSWORD LEVEL	EDITABLE	RANGE	DEFAULT	NOTES
Configuration ↓ Unit Configuration	Fan Mode	Admin Password level access only	X	Auto/Continuous/ Always On	Continuous	Auto= Intermittant operation during both occupied and unoccupied periods/ Continuous = Intermittant during unoccupied periods and continuous during occupied periods/Always on = fan operates continuously during both occupied and unoccupied periods
	Fan On Delay		X	0 - 30 sec	10 sec	Defines the delay time before the fan begins to operate after heating or cooling is started
	Fan Off Delay		X	0 - 180 sec	45 sec	Defines the amount of time the fan will continue to operate after heating or cooling is stopped
	Heating Enable		X	Disable/Enable	Enable	Provides capability to manually disable heating operation
	Cooling Enable		X	Disable/Enable	Enable	Provides capability to manually disable cooling operation
	Minimum SAT in Cooling		X	40 - 60 ° F	50 ° F	Defines the minimum acceptable operating temperature for the Supply Air
	Maximum SAT in Heating		X	80 - 140 ° F	110 ° F	Defines the maximum acceptable operating temperature for the Supply Air
	Damper Ventilation Position		X	0 - 100%	100%	Normally set to 100% if 2 position damper type or set to minimum ventilation position if damper type = DCV
	DCV Maximum Vent Position		X	0 - 100%	100%	Usually set at 100% - Used to limit maximum damper opening in DCV mode
	Filter Alarm Timer		X	0 - 9999 hrs	0 hrs	Disables Filter Alarm if set to 0
	Pushbutton Override		X	Disable/Enable	Enable	Enables Override Feature on Rnet sensor
	SPT Sensor Set Point Adjustment		X	Disable/Enable	Enable	Enables Set Point adjustment capability on Rnet Sensor
	Lockout Cooling if OAT <		X	-65 - 80 ° F	-65 ° F	Cooling is locked out when OAT is less than configured value and OAT is actively being broadcast
	Lockout Heating if OAT >		X	35 - 150 ° F	150 ° F	Heating is locked out when OAT is greater than configured value and OAT is actively being broadcast
	Power Fail Restart Delay		X	0 - 600 sec	60 sec	Delay before equipment starts
	Occupancy Schedules		X	Disable/Enable	Enable	Enables unit occupied
Set Point Separation	X	2 - 9 ° F	4 ° F	Used to enforce minimum set point separation		
Configuration ↓ Service ↓ Test	Test Mode	Admin Password level access only	X	Disable/Enable	Disable	Used to enable test mode. Will automatically reset to disable after 1 hour
	Fan Test		X	Disable/Enable	Disable	Used to test all fan speeds. Sequences fan from low to high and operates each speed for 1 minute. Resets to disable on completion
	Fan Speed			Off/Low Speed/Medium Speed/High Speed/On		Displays current fan operation
	Compressor Test		X	Disable/Enable	Disable	Used to test compressor cooling and heating operation. Sequences cooling stage 1, then stage 2, then heating stage 2 and reduces capacity to stage 1. Operates for 1 minute per step. Resets to disable on completion.
	Dehumidification Test		X	Disable/Enable	Disable	Used to test dehumidification mode - Operates for 2 minutes. Resets to disable on completion.
	Testing Compressor			Inactive/Heating/Cooling/Dehumidify/TimeGard Wait		Displays compressor test mode
	Aux Heating Test		X	Disable/Enable	Disable	Used to test auxiliary heat. Sequences fan on and enables heating coil for 1 minute. Resets to disable on completion
	H ₂ O Economizer Test		X	Disable/Enable	Disable	Used to test entering/return air water loop economizer coil operation. Sequences fan on and opens economizer coil water valve for 1 minute. Resets to disable on completion
	Preposition OA Damper		X	Disable/Enable	Disable	Used to preposition OA damper actuator to set proper preload
	Open Vent Damper 100%		X	Disable/Enable	Disable	Used to test OA damper operation
	SAT			° F		Displays SAT
	LCWT			° F		Displays Leaving Condenser Water Temperature

LEGEND

BAS	— Building Automation System
DCV	— Demand Controlled Ventilation
IAQ	— Indoor Air Quality
OAT	— Outdoor Air Temperature
RH	— Relative Humidity
SAT	— Supply Air Temperature
SPT	— Space Temperature
TPI	— Third Party Integration

APPENDIX A — WSHP SCREEN OPEN CONFIGURATION (cont)

SCREEN NAME	POINT NAME	PASSWORD LEVEL	EDITABLE	RANGE	DEFAULT	NOTES
Configuration ↓ Service Configuration	# of Fan Speeds	Admin Password level access only	X	1,2,3	3	Used to set number of fan motor speeds
	G Output Type		X	Fan On/Fan Low	Fan On	When set to Fan On, G output is energized when ever any fan speed is active (required for ECM and Fan control board). When set to Fan Low, output is only energized for Low Speed
	Compressor Stages		X	One Stage/Two Stages	One Stage	Defines the number of stages of compression
	Reversing Valve Type		X	O type output/B type output	O type	Determines reversing valve signal output type
	Leaving Air Auxiliary Heat Type		X	None/2-Position HW/1 Stage Electric/Modulating HW	None	Determines Auxiliary Reheat Coil Type
	Entering Air Water Economizer Type		X	None/2-Position/Modulating	None	Determines Entering Air Economizer Coil Type
	2-Position Water Valve Type		X	Normally Closed/Normally Open	Normally Closed	Determines type of 2-position water valve used
	Modulating Water Valve Type		X	Normally Closed/Normally Open	Normally Closed	Determines type of modulating water valve used
	Ventilation Damper Type		X	None/2-Position/DCV	None	Determines Type of ventilation damper control to be used
	Damper Actuator Type		X	(0-10 volt)/(2-10 volt)	0-10 volt	Used to determine ventilation damper output signal range (closed - open)
	Humidity Sensor		X	None/Installed	None	Set to Installed if Humidity sensor is present
	Factory Dehumidification Reheat Coil		X	None/Installed	None	Set to Installed if factory-installed dehumidification reheat coil is present
	Occupancy Input Logic		X	Occupied Open/Occupied Closed	Occupied CLOSED	Used to determine external occupancy switch contact occupied state
	Condensate Switch Alarm Delay		X	5 - 600 seconds	10 sec	Delay before equipment alarms on high condensate level
	Condensate Switch Alarm State		X	Alarm OPEN/Alarm CLOSED	Alarm CLOSED	Determine Alarm state of condensate switch input
	Minimum Condenser Water Temperature in Heating		X	25 - 60 ° F	60 ° F	Determines the minimum acceptable water loop temperature to start heating
	Maximum Condenser Water Temperature in Heating		X	65 - 100 ° F	90 ° F	Determines the maximum acceptable water loop temperature to start heating
	Minimum Condenser Water Temperature in Cooling		X	30 - 60 ° F	60 ° F	Determines the minimum acceptable water loop temperature to start cooling
	Maximum Condenser Water Temperature in Cooling		X	85 - 120 ° F	95 ° F	Determines the maximum acceptable water loop temperature to start cooling
	IAQ sensor minimum input		X	0 - 5 ma	4 ma	Minimum output current (mA) for IAQ sensor
	IAQ sensor maximum input		X	5 - 20 ma	20 ma	Maximum output current (mA) for IAQ sensor
	IAQ sensor minimum output		X	0 - 9999 ppm	0 ppm	Corresponding value in ppm for minimum output current
	IAQ sensor maximum output		X	0 - 9999 ppm	2000 ppm	Corresponding value in ppm for maximum output current

LEGEND

BAS	— Building Automation System
DCV	— Demand Controlled Ventilation
IAQ	— Indoor Air Quality
OAT	— Outdoor Air Temperature
RH	— Relative Humidity
SAT	— Supply Air Temperature
SPT	— Space Temperature
TPI	— Third Party Integration

APPENDIX A — WSHP SCREEN OPEN CONFIGURATION (cont)

SCREEN NAME	POINT NAME	PASSWORD LEVEL	EDITABLE	RANGE	DEFAULT	NOTES
Configuration ↓ Alarm Configuration	SPT Occupied Alarm Hysteresis	Admin Password level access only	X	2 - 20 ° F	5 ° F	Defines the hysteresis applied above the cooling and below the heating set points before an alarm condition will occur
	SPT Alarm Delay		X	0 - 30 min per degree	10 min	Used to calculate the delay time before an alarm is generated after the alarm condition occurs
	SPT Unoccupied Low Alarm Temperature		X	35 - 90 ° F	45 ° F	Defines the fixed unoccupied low SPT alarm limit
	SPT Unoccupied High Alarm Temperature		X	45 - 100 ° F	95 ° F	Defines the fixed unoccupied high SPT alarm limit
	SAT Low SAT Alarm Limit		X	15 - 90 ° F	45 ° F	Defines the fixed minimum SAT alarm limit
	SAT High SAT Alarm Limit		X	90 - 175 ° F	120 ° F	Defines the fixed maximum SAT alarm limit
	Condensate Overflow Alarm Delay		X	5 - 600 sec	10 sec	Defines the delay time before an alarm is generated after the alarm condition occurs
	Space Humidity Occupied High Alarm Limit		X	45% - 100%	100%	Defines the fixed occupied high space RH alarm limit
	Space Humidity Alarm Delay		X	0 - 30 min per % RH	5 min	Used to calculate the delay time before an alarm is generated after the alarm condition occurs
	Space Humidity Unoccupied High Alarm Limit		X	45% - 100%	100%	Defines the fixed unoccupied high space RH alarm limit
	IAQ/Ventilation Occupied High Alarm Limit		X	0 - 9999 ppm	1100 ppm	Defines the fixed occupied high space IAQ/Ventilation alarm limit
	IAQ/Ventilation Alarm Delay		X	0.1 - 1.0 min per ppm	0.25 min	Used to calculate the delay time before an alarm is generated after the alarm condition occurs
	Rnet Sensor SPT Alarm		X	Ignore/Display	Ignore	Determines if the SPT alarm is displayed on the local Rnet sensor
	Rnet Sensor SAT Alarm		X	Ignore/Display	Ignore	Determines if the SAT alarm is displayed on the local Rnet sensor
	Rnet Sensor Compressor Lockout Alarm		X	Ignore/Display	Display	Determines if the Compressor Lockout alarm is displayed on the local Rnet sensor
	Rnet Sensor Condenser Water Temperature Alarm		X	Ignore/Display	Display	Determines if the Condenser Water Temperature alarm is displayed on the local Rnet sensor
	Rnet Sensor Condensate Overflow Alarm		X	Ignore/Display	Display	Determines if the Condensate Overflow alarm is displayed on the local Rnet sensor
Rnet Sensor Dirty Filter Alarm	X	Ignore/Display	Display	Determines if the Dirty Filter alarm is displayed on the local Rnet sensor		
Rnet Sensor Space High Humidity Alarm	X	Ignore/Display	Ignore	Determines if the High Space RH alarm is displayed on the local Rnet sensor		
Configuration ↓ Linkage	Loop Control Network Number					See TPI
	Loop Control Network Address					See TPI
	Number of Linked Heat Pumps					See TPI

LEGEND

BAS — Building Automation System
DCV — Demand Controlled Ventilation
IAQ — Indoor Air Quality
OAT — Outdoor Air Temperature
RH — Relative Humidity
SAT — Supply Air Temperature
SPT — Space Temperature
TPI — Third Party Integration

**50PCH,PCV
START-UP CHECKLIST**

CUSTOMER: _____ JOB NAME: _____
MODEL NO.: _____ SERIAL NO.: _____ DATE: _____

I. PRE-START-UP

DOES THE UNIT VOLTAGE CORRESPOND WITH THE SUPPLY VOLTAGE AVAILABLE? (Y/N) _____

HAVE THE POWER AND CONTROL WIRING CONNECTIONS BEEN MADE AND TERMINALS TIGHT? (Y/N) _____

HAVE WATER CONNECTIONS BEEN MADE AND IS FLUID AVAILABLE AT HEAT EXCHANGER? (Y/N) _____

HAS PUMP BEEN TURNED ON AND ARE ISOLATION VALVES OPEN? (Y/N) _____

HAS CONDENSATE CONNECTION BEEN MADE AND IS A TRAP INSTALLED? (Y/N) _____

IS AN AIR FILTER INSTALLED? (Y/N) _____

II. START-UP

IS FAN OPERATING WHEN COMPRESSOR OPERATES? (Y/N) _____

IF 3-PHASE SCROLL COMPRESSOR IS PRESENT, VERIFY PROPER ROTATION PER INSTRUCTIONS. (Y/N) _____

UNIT VOLTAGE — COOLING OPERATION

PHASE AB VOLTS _____ PHASE BC VOLTS _____ PHASE CA VOLTS _____
(if 3 phase) (if 3 phase)

PHASE AB AMPS _____ PHASE BC AMPS _____ PHASE CA AMPS _____
(if 3 phase) (if 3 phase)

CONTROL VOLTAGE

IS CONTROL VOLTAGE ABOVE 21.6 VOLTS? (Y/N) _____.
IF NOT, CHECK FOR PROPER TRANSFORMER CONNECTION.

TEMPERATURES

FILL IN THE ANALYSIS CHART ATTACHED.

COAXIAL HEAT EXCHANGER	COOLING CYCLE:	FLUID IN	_____ F	FLUID OUT	_____ F	_____ PSI	_____ FLOW
	HEATING CYCLE:	FLUID IN	_____ F	FLUID OUT	_____ F	_____ PSI	_____ FLOW
AIR COIL	COOLING CYCLE:	AIR IN	_____ F	AIR OUT	_____ F		
	HEATING CYCLE:	AIR IN	_____ F	AIR OUT	_____ F		

HEATING CYCLE ANALYSIS

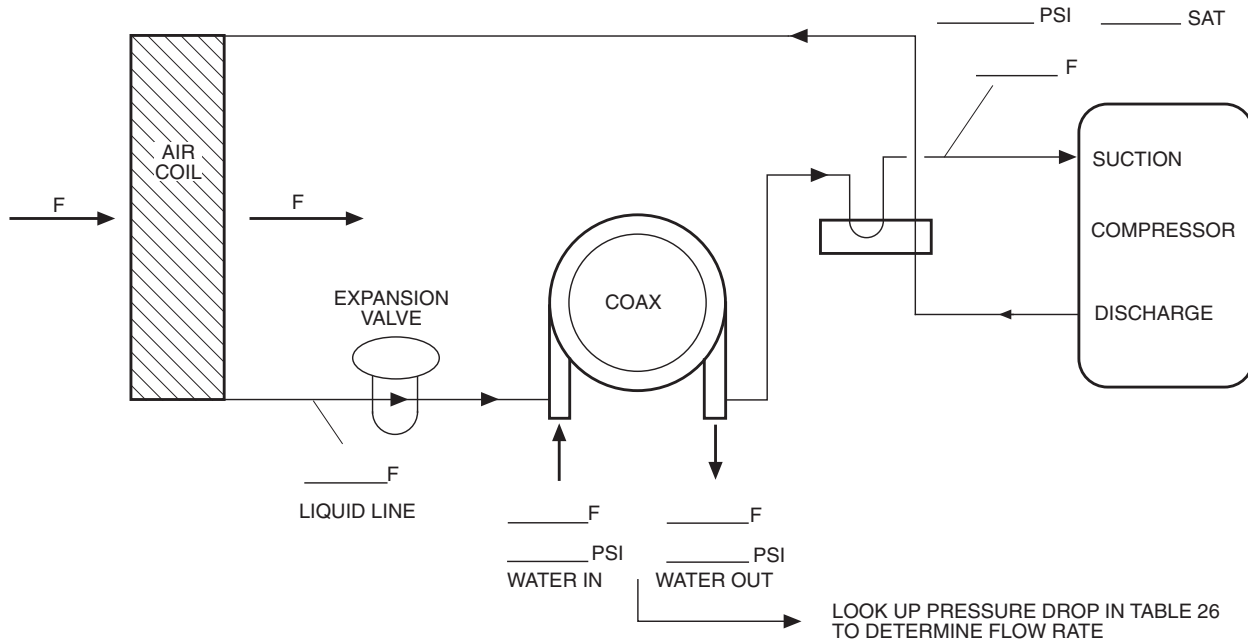

COOLING CYCLE ANALYSIS

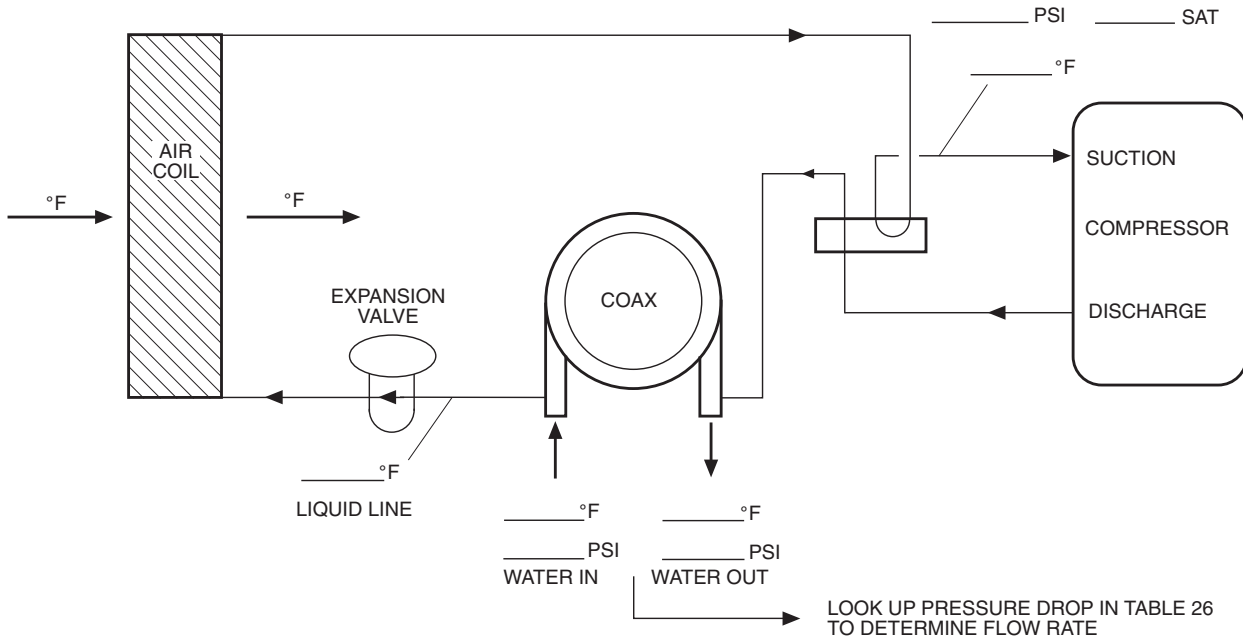

HEAT OF EXTRACTION (ABSORPTION) OR HEAT OF REJECTION =

$$\text{FLOW RATE (GPM)} \times \text{TEMP. DIFF. (DEG. F)} \times \text{FLUID FACTOR}^* = \text{Btu/hr}$$

SUPERHEAT = SUCTION TEMPERATURE – SUCTION SATURATION TEMPERATURE
= _____ (DEG F)

SUBCOOLING = DISCHARGE SATURATION TEMPERATURE – LIQUID LINE TEMPERATURE
= _____ (DEG F)

*Use 500 for water, 485 for antifreeze.

97B0038N05

CUT ALONG DOTTED LINE

Free Manuals Download Website

<http://myh66.com>

<http://usermanuals.us>

<http://www.somanuals.com>

<http://www.4manuals.cc>

<http://www.manual-lib.com>

<http://www.404manual.com>

<http://www.luxmanual.com>

<http://aubethermostatmanual.com>

Golf course search by state

<http://golfingnear.com>

Email search by domain

<http://emailbydomain.com>

Auto manuals search

<http://auto.somanuals.com>

TV manuals search

<http://tv.somanuals.com>