



Installation, Start-Up, and Service Instructions

CONTENTS

	Page
SAFETY CONSIDERATIONS	1,2
GENERAL	2
INSTALLATION	2-12
Step 1 — Check Jobsite	2
Step 2 — Check Unit	2
• STORAGE	
• PROTECTION	
• INSPECT UNIT	
Step 3 — Locate Unit	5
Step 4 — Mount Unit	5
Step 5 — Connect Piping	5
• WATER SUPPLY AND QUALITY	
• WATER LOOP APPLICATIONS	
• GROUND-WATER APPLICATIONS	
• GROUND-LOOP APPLICATIONS	
• UNIT LOAD PIPING	
Step 6 — Wire Electrical Connections	7
• POWER CONNECTION	
• SUPPLY VOLTAGE	
• EXTERNAL LOOP POWER CONNECTION	
• 220-V OPERATION	
• 380-V OPERATION	
Step 7 — Wire Low Voltage Connections	12
• THERMOSTAT CONNECTIONS	
• WATER FREEZE PROTECTION	
• ACCESSORY CONNECTIONS	
• WATER SOLENOID VALVES	
PRE-START-UP	12
System Checkout	12
FIELD SELECTABLE INPUTS	13,14
Complete C Control Jumper Settings	13
Complete C Control DIP Switches	13
Deluxe D Control Jumper Settings	13
Deluxe D Control DIP Switches	13
Deluxe D Control Accessory Relay Configurations	13
START-UP	14-16
Operating Limits	14
Unit Start-Up	14
Scroll Compressor Rotation	14
Flow Regulation	14
Cleaning and Flushing	15
Antifreeze	15
Cooling Tower/Boiler Systems	16
Ground Coupled, Closed Loop and Plateframe Heat Exchanger Well Systems	16
OPERATION	16
Power Up Mode	16
Units with Aquazone Complete C Control	16
Units with Aquazone Deluxe D Control	16
SYSTEM TEST	16,17
Test Mode	16
Retry Mode	17
Aquazone Deluxe D Control LED Indicators	17
SERVICE	18,19
Water Coil	18
Refrigerant System	18
Condenser Cleaning	18
Checking System Charge	19
Refrigerant Charging	19
TROUBLESHOOTING	19-21
50PSW START-UP CHECKLIST	CL-1,CL-2

IMPORTANT: Read the entire instruction manual before starting installation.

SAFETY CONSIDERATIONS

Installation and servicing of air-conditioning equipment can be hazardous due to system pressure and electrical components. Only trained and qualified service personnel should install, repair, or service air-conditioning equipment.

Untrained personnel can perform basic maintenance function of cleaning coils. All other operations should be performed by trained service personnel. When working on air-conditioning equipment, observe precautions in the literature, tags and labels attached to the unit, and other safety precautions that may apply.

Improper installation, adjustment, alteration, service, maintenance, or use can cause explosion, fire, electrical shock or other conditions which may cause personal injury or property damage. Consult a qualified installer, service agency, or your distributor or branch for information or assistance. The qualified installer or agency must use factory-authorized kits or accessories when modifying this product. Refer to the individual instructions packaged with the kits or accessories when installing.

Follow all safety codes. Wear safety glasses and work gloves. Use quenching cloth for brazing operations. Have fire extinguisher available. Read these instructions thoroughly and follow all warnings or cautions attached to the unit. Consult local building codes and the National Electrical Code (NEC, U.S.A.) for special installation requirements.

Understand the signal words — DANGER, WARNING, and CAUTION. DANGER identifies the most serious hazards which will result in severe personal injury or death. WARNING signifies hazards that could result in personal injury or death. CAUTION is used to identify unsafe practices, which would result in minor personal injury or product and property damage.

Recognize safety information. This is the safety alert symbol () . When you see this symbol on the unit and in instructions or manuals, be alert to the potential for personal injury.

 WARNING
Electrical shock can cause personal injury or death. Before installing or servicing system, always turn off main power to system. There may be more than one disconnect switch. Turn off accessory heater power if applicable. Install lock-out tag.

GENERAL

The Aquazone™ 50PSW water source heat pump (WSHP) is a single-package vertically mounted unit with electronic controls designed for year-round cooling and heating.

IMPORTANT: The installation of water source heat pump units and all associated components, parts, and accessories which make up the installation shall be in accordance with the regulations of ALL authorities having jurisdiction and MUST conform to all applicable codes. It is the responsibility of the installing contractor to determine and comply with ALL applicable codes and regulations.

INSTALLATION

Step 1 — Check Jobsite — Installation, operation and maintenance instructions are provided with each unit. Before unit start-up, read all manuals and become familiar with the unit and its operation. Thoroughly check out the system before operation. Complete the inspections and instructions listed below to prepare a unit for installation. See Table 1 for unit physical data.

Units are designed for indoor installation only. Be sure to allow adequate space around the unit for servicing. See Fig. 1 and 2 for overall unit dimensions.

These units are not approved for outdoor installation and must be installed indoors in the structure being conditioned. Do not locate in areas where ambient conditions are not maintained within 4.4 to 37.8 C.

 CAUTION
To avoid equipment damage, do not use these units as a source of heating or cooling during the construction process. The mechanical components used in these units can quickly become clogged with construction dirt and debris which may cause system damage.

Step 2 — Check Unit — Upon receipt of shipment at the jobsite, carefully check the shipment against the bill of lading. Make sure all units have been received. Inspect the carton or crating of each unit, and inspect each unit for damage. Ensure the shipping company makes proper notation of any shortages or damage on all copies of the freight bill. Concealed damage not discovered during unloading must be reported to the shipping company within 15 days of receipt of shipment.

NOTE: It is the responsibility of the purchaser to file all necessary claims with the shipping company.

1. Verify unit is correct model for entering water temperature of job.
2. Be sure the location chosen for unit installation provides ambient temperatures maintained above freezing. Well water applications are especially susceptible to freezing.
3. Be sure the installation location is isolated from sleeping areas, private offices and other acoustically sensitive spaces.

NOTE: A sound control accessory package may be used to help eliminate sound in sensitive spaces.

4. Provide sufficient access to allow maintenance and servicing of the compressor and coils.
5. Provide an unobstructed path to the unit within the closet or mechanical room. Space should be sufficient to allow removal of unit if necessary.
6. Provide ready access to water valves and fittings, and screwdriver access to unit side panels.
7. Where access to side panels is limited, pre-removal of the control box side mounting screws may be necessary for future servicing.

STORAGE — If the equipment is not needed for immediate installation upon its arrival at the jobsite, it should be left in its shipping carton and stored in a clean, dry area of the building or in a warehouse. Units must be stored in an upright position at all times. If carton stacking is necessary, stack units a maximum of 3 cartons high. Do not remove any equipment from its shipping package until it is needed for installation.

Table 1 — 50PSW Unit Physical Data

50PSW UNIT SIZE	036	060	120	180	360
NOMINAL CAPACITY (kW)	10.5	17.6	35.2	49.2	105.5
WEIGHT (kg)					
Operating	158	163	329	358	604
Packaged	169	175	349	363	608
COMPRESSOR (qty)	Scroll (1)	Scroll (1)	Scroll (2)	Scroll (1)	Scroll (2)
REFRIGERANT TYPE	R-410A				
Factory Charge Per Circuit (kg)	2.04	2.83	2.83	6.80	6.80
CONNECTIONS, FPT (in.)					
Commercial Load/Source	3/4	1	1 1/2	2	2
HWG Water In/Out		1/2		N/A	
WATER VOLUME (L)	3.64	5.04	10.02	13.27	25.44

LEGEND

HWG — Hot Water Generator

NOTES:

1. Maximum working pressure on the base unit is 3445 kPa.
2. Units have a dual isolated compressor mounting.
3. Units have a balanced port expansion valve (TXV).
4. Insulated source and load water coils are standard.
5. Insulated refrigerant circuit is standard.
6. Compressor is on (green) light and fault on (red) light.

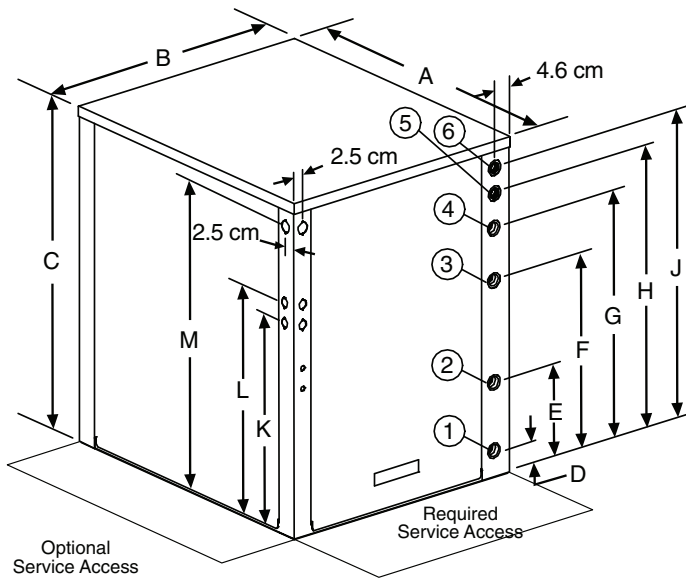

SIZES 036,060

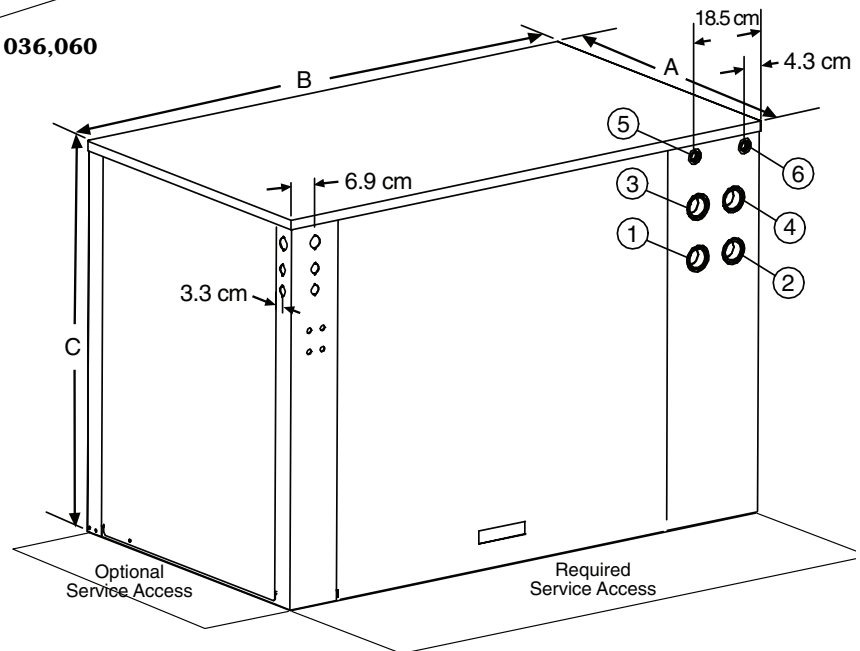

SIZE 120

50PSW UNIT SIZE	OVERALL CABINET (mm)			WATER CONNECTIONS (mm)						ELECTRIC ACCESS PLUGS (mm)		
				1	2	3	4	5	6			
	A Depth	B Width	C Height	Source (Outdoor)		Load (Indoor)		HWG		K Low Voltage	L External Pump	M Power Supply
036,060	778	645	838	D 69	E 239	F 493	G 622	H 709	J 772	531	582	785
120	778	1344	940	640	640	765	765	886	886	759	810	874

LEGEND

HWG — Hot Water Generator

HACR — Heating, Air Conditioning, and Refrigeration

NOTES:

1. Dimensions shown in centimeters unless noted otherwise.
2. HACR circuit breaker in U.S.A. only.

Fig. 1 — 50PSW036-120 Unit

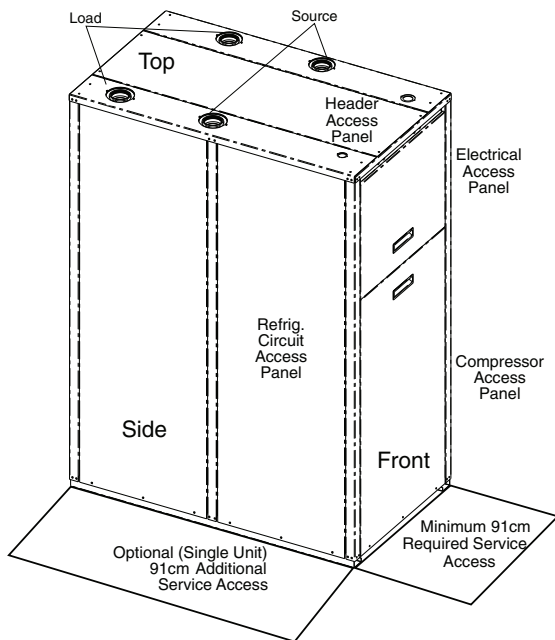
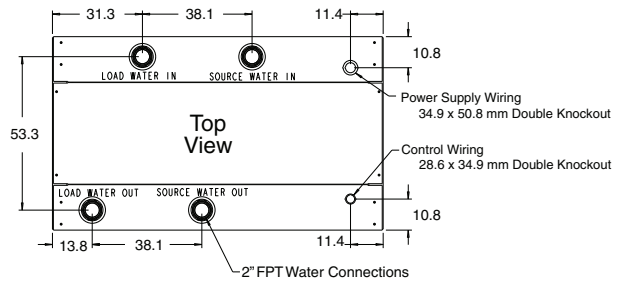
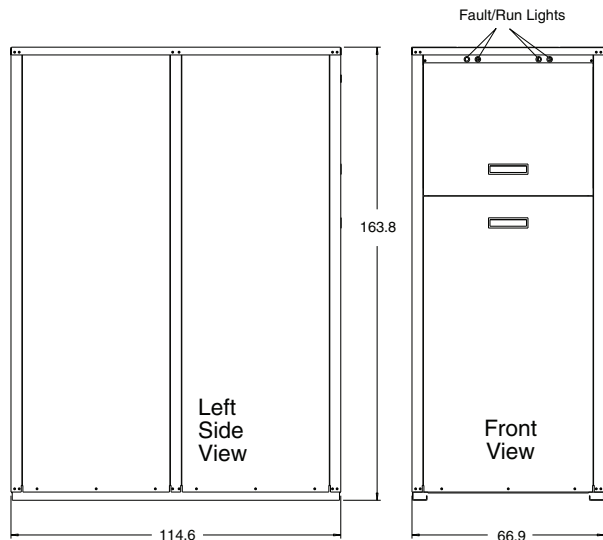

LEGEND

FPT — Female Pipe Thread

NOTES:

1. Dimensions shown in centimeters unless noted otherwise.
2. For multiple units placed side by side, allow 1.2 m minimum front access for service and maintenance.

Fig. 2 — 50PSW180,360 Unit

PROTECTION — Once the units are properly positioned on the jobsite, they must be covered with either a shipping carton, vinyl film, or an equivalent protective covering. Open ends of pipes stored on the jobsite must be capped. This precaution is especially important in areas where painting, plastering, or spraying of fireproof material, etc., is not yet complete. Foreign material that is allowed to accumulate within the units can prevent proper start-up and necessitate costly clean-up operations.

Before installing any of the system components, be sure to examine each pipe, fitting, and valve, and remove any dirt or foreign material found in or on these components.

CAUTION

DO NOT store or install units in corrosive environments or in locations subject to temperature or humidity extremes (e.g., attics, garages, rooftops, etc.). Corrosive conditions and high temperature or humidity can significantly reduce performance, reliability, and service life. Always move units in an upright position. Tilting units on their sides may cause equipment damage.

INSPECT UNIT — To prepare the unit for installation, complete the procedures listed below:

1. Compare the electrical data on the unit nameplate with ordering and shipping information to verify that the correct unit has been shipped.
2. Verify that the unit is the correct model for the entering water temperature of the job.
3. Wait to remove the packaging until the unit is ready for installation.
4. Verify that the refrigerant tubing is free of kinks or dents, and that it does not touch other unit components.
5. Inspect all electrical connections. Be sure connections are clean and tight at the terminals.
6. Loosen bolts and remove shipping clamps on compressors equipped with external spring vibration isolators. Compressors are internally spring-mounted.
7. Locate and verify any accessory kit located in compressor section.

- Remove any access panel screws that may be difficult to remove once unit is installed.

Step 3 — Locate Unit — The following guidelines should be considered when choosing a location for the WSHP:

- Units are for indoor use only.
- Provide sufficient space for water and electrical connections.
- Locate unit in an area that allows for easy access and removal of access panels.
- Allow enough space for service personnel to perform maintenance.

Step 4 — Mount Unit — Mount unit as shown in Fig. 3. Rod attachments must be able to support the weight of the unit. See Table 1 for unit operating weight.

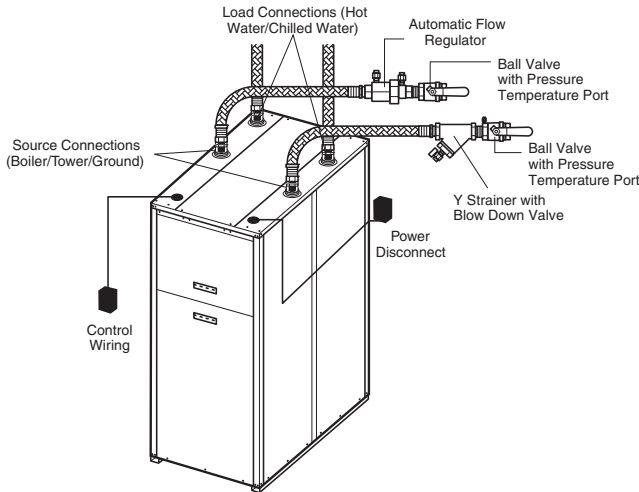

Fig. 3 — Typical Water Loop System — Boiler, Tower, or Ground (Sizes 180,360 Shown)

Step 5 — Connect Piping — Depending on the application, there are 3 types of WSHP piping systems to choose from: water loop, ground-water and ground loop. Refer to the Carrier System Design Manual for additional information.

All WSHP units utilize low temperature soldered female pipe thread fittings for water connections to prevent annealing and out-of-round leak problems which are typically associated with high temperature brazed connections. When making piping connections, consider the following:

- A backup wrench must be used when making screw connections to unit to prevent internal damage to piping.
- Insulation may be required on piping to avoid condensation in the case where fluid in loop piping operates at temperatures below dew point of adjacent air.
- Piping systems that contain steel pipes or fittings may be subject to galvanic corrosion. Dielectric fittings may be used to isolate the steel parts of the system to avoid galvanic corrosion.
- Units may be manifolded together via top water connects to get increased temperatures, when piped in series, or greater capacity, when piped in parallel.

WATER SUPPLY AND QUALITY — Check water supply. Water supply should be plentiful and of good quality. See Table 2 for water quality guidelines.

IMPORTANT: Failure to comply with the above required water quality and quantity limitations and the closed-system application design requirements may cause damage to the tube-in-tube heat exchanger that is not the responsibility of the manufacturer.

In all applications, the quality of the water circulated through the heat exchanger must fall within the ranges listed in the Water Quality Guidelines table. Consult a local water treatment firm, independent testing facility, or local water authority for specific recommendations to maintain water quality within the published limits.

WATER LOOP APPLICATIONS — Water loop applications usually include a number of units plumbed to a common piping system. Maintenance to any of these units can introduce air into the piping system. Therefore, air elimination equipment comprises a major portion of the mechanical room plumbing.

The flow rate is usually set between 2.9 L/m and 3.9 L/m per kW of cooling capacity. For proper maintenance and servicing, pressure-temperature (P/T) ports are necessary for temperature and flow verification.

In addition to complying with any applicable codes, consider the following for system piping:

- Piping systems utilizing water temperatures below 10.0 C require 13 mm closed cell insulation on all piping surfaces to eliminate condensation.
- All plastic to metal threaded fittings should be avoided due to the potential to leak. Use a flange fitted substitute.
- Teflon* tape thread sealant is recommended to minimize internal fouling of the heat exchanger.
- Use backup wrench. Do not overtighten connections.
- Route piping to avoid service access areas to unit.
- The piping system should be flushed prior to operation to remove dirt and foreign materials from the system.

Cooling tower/boiler systems typically use a common loop maintained between 16 and 32 C. The use of a closed circuit evaporative cooling tower with a secondary heat exchanger between the tower and the water loop is recommended. If an open type cooling tower is used continuously, chemical treatment and filtering will be necessary.

GROUND-WATER APPLICATIONS — In addition to complying with any applicable codes, consider the following for system piping:

- Install shut-off valves for servicing.
- Install pressure-temperature plugs to measure flow and temperature.
- Boiler drains and other valves should be connected using a “T” connector to allow acid flushing for the heat exchanger.
- Do not overtighten connections.
- Route piping to avoid service access areas to unit.
- Use PVC SCH80 or copper piping material.

NOTE: PVC SCH40 should *not* be used due to system high pressure and temperature extremes.

GROUND-LOOP APPLICATIONS — Temperatures between -3.9 and 43.3 C and a cooling capacity of 2.9 L/m and 3.9 L/m per kW are recommended. In addition to complying with any applicable codes, consider the following for system piping:

- Piping materials should be limited to only polyethylene fusion in the buried sections of the loop.
- Galvanized or steel fittings should not be used at any time due to corrosion.
- All plastic to metal threaded fittings should be avoided due to the potential to leak. Use a flange fitted substitute.
- Do not overtighten connections.
- Route piping to avoid service access areas to unit.
- Pressure-temperature (P/T) plugs should be used to measure flow of pressure drop.

*Teflon is a trademark of E. I. du Pont de Nemours and Company.

Table 2 — Water Quality Guidelines

CONDITION	HX MATERIAL*	CLOSED RECIRCULATING†	OPEN LOOP AND RECIRCULATING WELL**		
Scaling Potential — Primary Measurement					
Above the given limits, scaling is likely to occur. Scaling indexes should be calculated using the limits below.					
pH/Calcium Hardness Method	All	N/A	pH < 7.5 and Ca Hardness, <100 ppm		
Index Limits for Probable Scaling Situations (Operation outside these limits is not recommended.)					
Scaling indexes should be calculated at 150 F for direct use and HWG applications, and at 90 F for indirect HX use. A monitoring plan should be implemented.					
Ryznar Stability Index	All	N/A	6.0 - 7.5 If >7.5 minimize steel pipe use.		
Langelier Saturation Index	All	N/A	-0.5 to +0.5 If <-0.5 minimize steel pipe use. Based upon 150 F HWG and direct well, 85 F indirect well HX.		
Iron Fouling					
Iron Fe ²⁺ (Ferrous) (Bacterial Iron Potential)	All	N/A	<0.2 ppm (Ferrous) If Fe ²⁺ (ferrous) >0.2 ppm with pH 6 - 8, O ₂ <5 ppm check for iron bacteria.		
Iron Fouling	All	N/A	<0.5 ppm of Oxygen Above this level deposition will occur.		
Corrosion Prevention††					
pH	All	6 - 8.5 Monitor/treat as needed.	6 - 8.5 Minimize steel pipe below 7 and no open tanks with pH <8.		
Hydrogen Sulfide (H ₂ S)	All	N/A	<0.5 ppm At H ₂ S>0.2 ppm, avoid use of copper and cupronickel piping of HXs. Rotten egg smell appears at 0.5 ppm level. Copper alloy (bronze or brass) cast components are okay to <0.5 ppm.		
Ammonia Ion as Hydroxide, Chloride, Nitrate and Sulfate Compounds	All	N/A	<0.5 ppm		
Maximum Chloride Levels			Maximum allowable at maximum water temperature.		
			50 F (10 C)	75 F (24 C)	100 F (38 C)
	Copper	N/A	<20 ppm	NR	NR
	Cupronickel	N/A	<150 ppm	NR	NR
	304 SS	N/A	<400 ppm	<250 ppm	<150 ppm
	316 SS	N/A	<1000 ppm	<550 ppm	<375 ppm
	Titanium	N/A	>1000 ppm	>550 ppm	>375 ppm
Erosion and Clogging					
Particulate Size and Erosion	All	<10 ppm of particles and a maximum velocity of 6 fps. Filtered for maximum 800 micron size.	<10 ppm (<1 ppm "sandfree" for reinjection) of particles and a maximum velocity of 6 fps. Filtered for maximum 800 micron size. Any particulate that is not removed can potentially clog components.		

LEGEND

- HWG**— Hot Water Generator
- HX** — Heat Exchanger
- N/A** — Design Limits Not Applicable Considering Recirculating Potable Water
- NR** — Application Not Recommended
- SS** — Stainless Steel

*Heat exchanger materials considered are copper, cupronickel, 304 SS (stainless steel), 316 SS, titanium.

†Closed recirculating system is identified by a closed pressurized piping system.

**Recirculating open wells should observe the open recirculating design considerations.

††If the concentration of these corrosives exceeds the maximum allowable level, then the potential for serious corrosion problems exists.

Sulfides in the water quickly oxidize when exposed to air, requiring that no agitation occur as the sample is taken. Unless tested immediately at the site, the sample will require stabilization with a few drops of one Molar zinc acetate solution, allowing accurate sulfide determination up to 24 hours after sampling. A low pH and high alkalinity cause system problems, even when both values are within ranges shown. The term pH refers to the acidity, basicity, or neutrality of the water supply. Below 7.0, the water is considered to be acidic. Above 7.0, water is considered to be basic. Neutral water contains a pH of 7.0.

To convert ppm to grains per gallon, divide by 17. Hardness in mg/l is equivalent to ppm.

UNIT LOAD PIPING — For applications with wide temperature variation such as heating/cooling coils:

- Use piping materials that are rated for the maximum temperature and pressure combination. This excludes PVC for most heating applications.
- Ensure load water flow in high temperature heating applications is at least 3.2 L/m per kW to improve performance and reduce nuisance high pressure faults.
- DO NOT employ plastic to metal threaded joints.
- Utilize a pressure tank and air separator vent system to equalize pressure and remove air.
- Employ an 800-micron particulate strainer in both load and source plumbing to protect the plate heat exchanger.

Swimming Pool Hot Tub Applications — Load heat exchanger should be isolated with secondary heat exchanger constructed of anti-corrosion material in all chlorine/bromine fluid applications.

Potable Water Applications

- Load coax material should always be vented double walled for use in potable water systems.
- Ensure load water flow in high temperature heating applications is at least 3.2 L/m per kW to improve performance and reduce nuisance high pressure faults.

Step 6 — Wire Electrical Connections

⚠ WARNING

To avoid possible injury or death due to electrical shock, open the power supply disconnect switch and secure it in an open position during installation. Install lockout tag.

⚠ CAUTION

Use only copper conductors for field-installed electrical wiring. Unit terminals are not designed to accept other types of conductors. Failure to heed this warning could result in equipment damage.

All field-installed wiring, including the electrical ground, MUST comply with the National Electrical Code (NEC) as well as applicable local codes. In addition, all field wiring must conform to the Class II temperature limitations described in the NEC.

Operating voltage must be the same voltage and phase as shown in Table 3.

Refer to unit wiring diagrams Fig. 4-8 for a schematic of the field connections which must be made by the installing (or electrical) contractor.

Consult the unit wiring diagram located on the inside of the compressor access panel to ensure proper electrical hookup. The installing (or electrical) contractor must make the field connections when using field-supplied disconnect.

Make all final electrical connections with a length of flexible conduit to minimize vibration and sound transmission to the building.

POWER CONNECTION — Line voltage connection is made by connecting incoming line voltage wires to L1, L2, and L3 on the power distribution block.

SUPPLY VOLTAGE — Operating voltage to unit must be within voltage range indicated on unit nameplate.

Voltages between phases must be balanced within 2%. Use the following formula to determine the percentage voltage imbalance:

% Voltage Imbalance

$$= 100 \times \frac{\text{max voltage deviation from average voltage}}{\text{average voltage}}$$

Example: Supply voltage is 380-3-50.

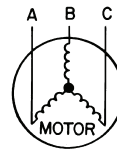

AB = 372 volts

BC = 376 volts

AC = 384 volts

$$\text{Average Voltage} = \frac{372 + 376 + 384}{3}$$

$$= \frac{1132}{3}$$

$$= 377$$

Determine maximum deviation from average voltage:

(AB) $372 - 377 = 5 \text{ v}$

(BC) $376 - 377 = 1 \text{ v}$

(AC) $384 - 377 = 7 \text{ v}$

Maximum deviation is 7 v.

Determine percent voltage imbalance.

$$\begin{aligned} \% \text{ Voltage Imbalance} &= 100 \times \frac{7}{377} \\ &= 1.86\% \end{aligned}$$

This amount of phase imbalance is satisfactory as it is below the maximum allowable 2%.

Operation on improper line voltage or excessive phase imbalance constitutes abuse and may cause damage to electrical components.

NOTE: If more than 2% voltage imbalance is present, contact local electric utility.

Table 3 — 50PSW Electrical Data

50PSW UNIT SIZE	VOLTAGE (V-Ph-Hz)	VOLTAGE RANGE MIN/MAX	COMPRESSOR			TOTAL FLA	MCA	MOCP*
			RLA	LRA	QTY			
036	220/240-1-50	198/264	13.5	67	1	13.5	16.9	30
	380/420-3-50	342/462	5.4	38	1	5.4	6.8	15
060	220/240-1-50	198/264	24.5	153	1	24.5	30.6	50
	380/420-3-50	342/462	9.6	74	1	9.6	12.0	20
120	220/240-1-50	198/264	24.5	153	2	49.0	55.1	80
	380/420-3-50	342/462	9.6	74	2	19.2	21.6	30
180	220/240-1-50	198/264	44.9	273	1	44.9	56.1	100
	380/420-3-50	342/462	18.6	118	1	18.6	23.3	40
360	220/240-1-50	198/264	44.9	273	2	89.8	101.0	125
	380/420-3-50	342/462	18.6	118	2	37.2	46.6	60

LEGEND

- FLA — Full Load Amps
- HACR — Heating, Air Conditioning, and Refrigeration
- LRA — Locked Rotor Amps
- MCA — Minimum Circuit Amps
- MOCP — Minimum Overcurrent Protection
- RLA — Rated Load Amps

*Time-delay fuse or HACR circuit breaker.



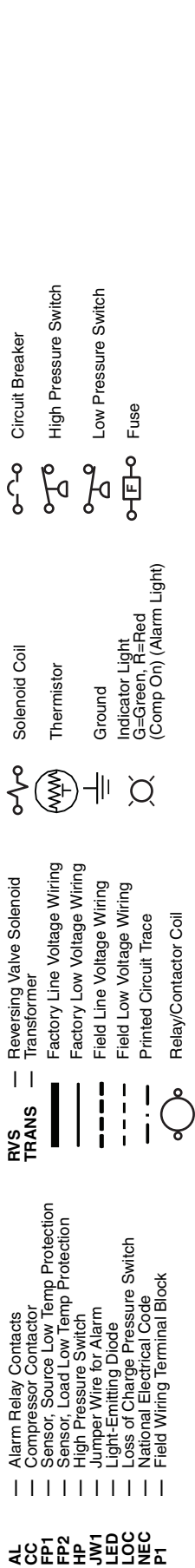

- NOTES:**
- Compressor motor thermally protected internally.
 - All wiring to the unit must comply with NEC and local codes.
 - Transformer is wired to 265 v lead (BRN) for 265-1-50 units. For 220/240 v operation, disconnect BRN lead at L1 and connect ORG lead to L1. Insulate open ends of BRN and RED leads. Transformer is energy limiting or may have circuit breaker.
 - FP1 thermistor provides freeze protection for source water. When using anti-freeze solutions, cut JW3 jumper.
 - Refer to or Thermostat Installation, Application and Operation Manual for control wiring to the unit. Low voltage wiring must be "Class 1" and voltage rating equal to or greater than unit supply voltage.

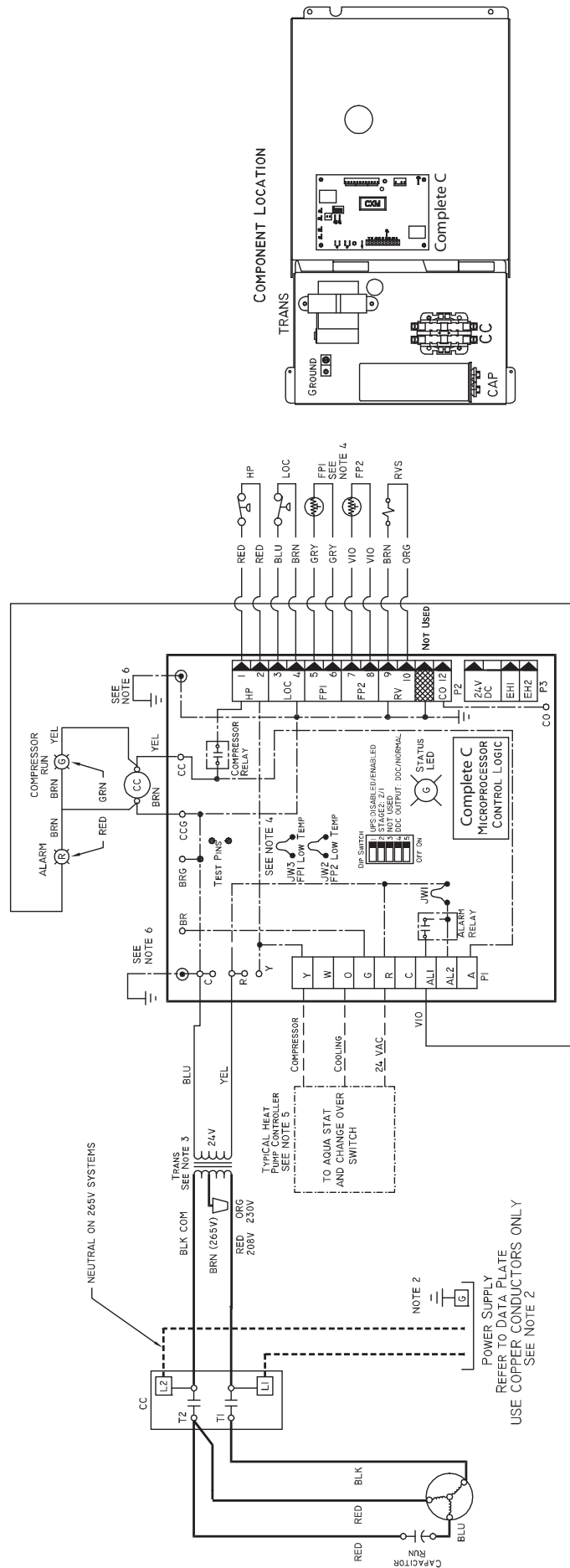

Fig. 4 — Typical Aquazone™ 50PSW036-060 Complete C Control Wiring, Single-Phase

- AL Alarm Relay Contacts
- ASTAT Aquastat Device
- COMP Compressor
- CC Compressor Contactor
- DTS Discharge Temperature Switch
- FP1 Sensor, Source Low Temp Protection
- FP2 Sensor, Load Low Temp Protection
- HP High Pressure Switch
- HPWS Hot Pressure Water Switch
- HWG Hot Water Generator
- JW1 Jumper Wire for Alarm
- LOC Loss of Charge Pressure Switch

- L-WTR Load Water
- NEC National Electrical Code
- P1 Field Wiring Terminal Block
- RVS Reversing Valve Solenoid
- S-WTR Source Water
- TRANS Transformer
- Factory Line Voltage Wiring
- Factory Low Voltage Wiring
- Field Line Voltage Wiring
- Field Low Voltage Wiring
- Printed Circuit Trace

- Relay/Contactor Coil
- Solenoid Coil
- Thermistor
- Ground
- Indicator Light
- G=Green, R=Red (Comp On) (Alarm Light)
- Circuit Breaker
- High Pressure Switch
- Low Pressure Switch
- Fuse

TRANSFORMER PRIMARY LEAD COLORS	PRIMARY VOLTAGE	PRIMARY LEAD COLOR
BRN	230	BRN
BLK	230	BLK
WHT	230	WHT
BLU	230	BLU
GRN	230	GRN
GRY	230	GRY
RED	230	RED
BLK	480	BLK
WHT	480	WHT
BLU	480	BLU
GRN	480	GRN
GRY	480	GRY
RED	480	RED

POWER SUPPLY REFER TO WIRING DIAGRAM FOR CONDUCTORS ONLY SEE NOTE 2

USE COPPER CONDUCTORS ONLY

SEE NOTE 2

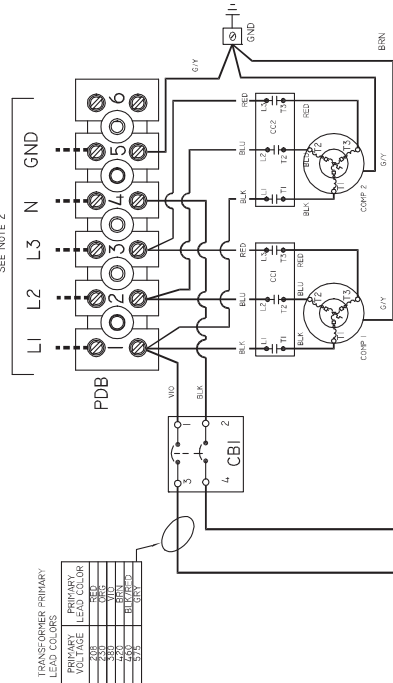

NOTES:

1. Compressor thermally protected internally.
2. All wiring to the unit must comply with NEC and local codes.
3. Transformer is wired to 380 v lead (VIO) for 380-3-50 operation. For 420 v operation switch VIO and BRN leads at L1 and insulate VIO lead.
4. FP1 thermistor provides freeze protection for source water. When using anti-freeze solutions, cut JW3 jumper.
5. Check installation wiring information for controller hookup. Control wiring must be Class 1 and voltage rating equal to or greater than unit supply voltage.
6. Transformer secondary ground via Complete C board standoff and screws to control box. (Ground available from top 2 standoffs as shown.)
7. Aquastat is supplied with unit and must be wired in series with the hot leg of the pump. Aquastat is rated for voltages up to 277 V.

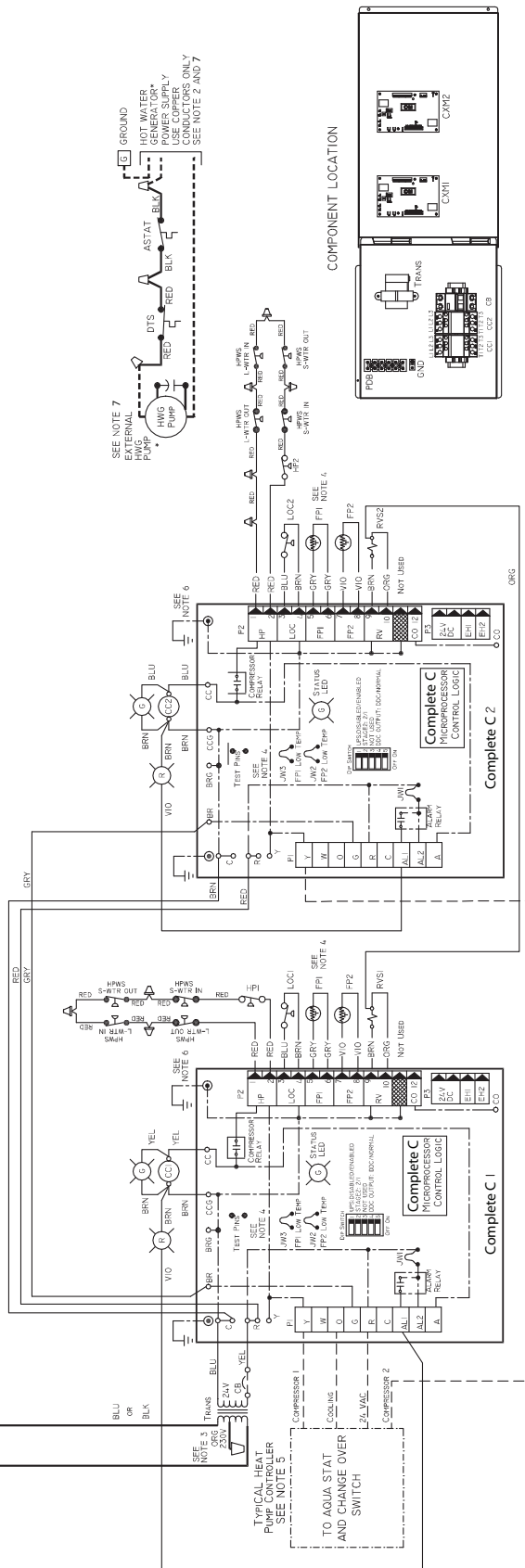

Fig. 5 — Typical Aquazone™ 50PSW120 Complete C Control Wiring, 3-Phase

- Alarm Relay Contacts
- Aquastat Device
- COMP Compressor
- CC Compressor Contactor
- DTS Discharge Temperature Switch
- FP1 Sensor, Source Low Temp Protection
- FP2 Sensor, Load Low Temp Protection
- HP High Pressure Switch
- HPWS Hot Water Generator
- HWG Hot Water Generator
- JW1 Jumper Wire for Alarm
- LED Light Emitting Diode
- LOC Loss of Charge Pressure Switch
- L-WTR Load Water

- MS Motor Switch
- NEC National Electrical Code
- P1 Field Wiring Terminal Block
- RVS Reversing Valve Solenoid
- S-WTR Source Water
- TRANS Transformer
- Factory Line Voltage Wiring
- Field Low Voltage Wiring
- Field Line Voltage Wiring
- Field Low Voltage Wiring
- Printed Circuit Trace

- Relay/Contactor Coil
- Solenoid Coil
- Thermistor
- ⊖ Ground
- Indicator Light
- G=Green, R=Red (Comp On) (Alarm Light)

- Circuit Breaker
- High Pressure Switch
- Low Pressure Switch
- Fuse

- NOTES:**
1. Compressor thermally protected internally.
 2. All wiring to the unit must comply with NEC and local codes.
 3. Transformer is wired to 380 v lead (VIO) for 380-350 operation. For 420 v operation switch VIO and BRN leads at L1 and insulate VIO lead.
 4. FP1 thermistor provides freeze protection for source water. When using antifreeze solutions, cut JW3 jumper.
 5. Check installation wiring information for controller hookup. Control wiring must be Class 1 and voltage rating equal to or greater than unit supply voltage.
 6. Transformer secondary ground via Complete C board standoff and screws to control box. (Ground available from top 2 standoffs as shown.)
 7. Aquastat is supplied with unit and must be wired in series with the hot leg of the pump. Aquastat is rated for voltages up to 277 v.

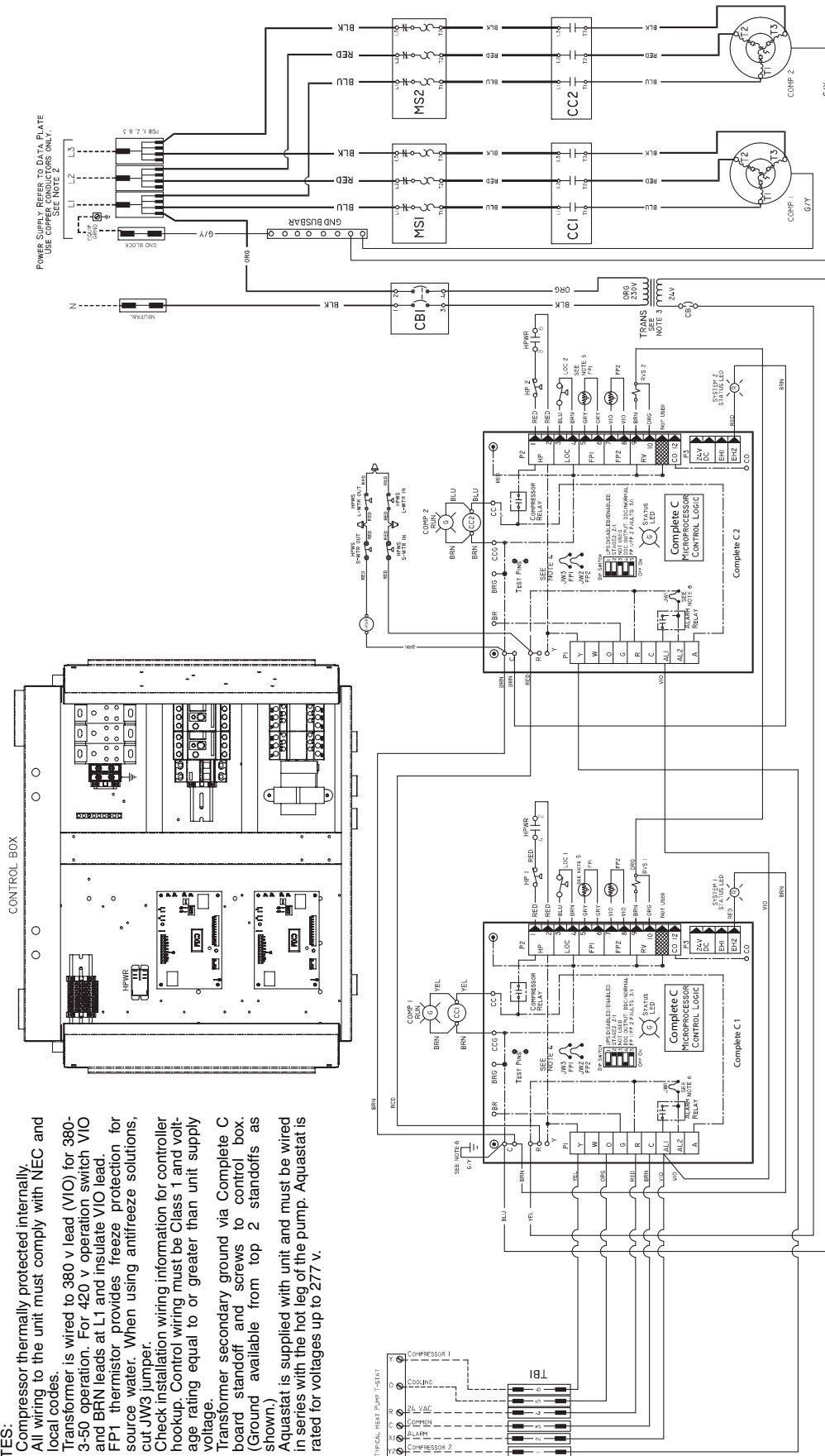

Fig. 6 — Typical Aquazone™ 50PSW360 Complete C Control Wiring, 3-Phase

- AL Alarm Relay Contacts
- ASTAT Aquastat Device
- COMP Compressor
- CC Compressor Contactor
- DTS Discharge Temperature Switch
- FP1 Sensor, Source Low Temp Protection
- FP2 Sensor, Load Low Temp Protection
- HP High Pressure Switch
- HPWS High Pressure Water Switch
- HWG Hot Water Generator
- JW1 Jumper Wire for Alarm
- LED Light Emitting Diode
- LOC Loss of Charge Pressure Switch
- L-WTR Load Water

- MS Motor Switch
- NEC National Electrical Code
- P1 Field Wiring Terminal Block
- RVS Reversing Valve Solenoid
- S-WTR Source Water Transformer
- TRANS Factory Line Voltage Wiring
- TRNS Factory Low Voltage Wiring
- TRNS Field Line Voltage Wiring
- TRNS Field Low Voltage Wiring
- TRNS Printed Circuit Trace

- Relay/Contactor Coil
- Solenoid Coil
- Thermistor
- Ground
- Indicator Light
G=Green, R=Red
(Comp On) (Alarm Light)

- Circuit Breaker
- High Pressure Switch
- Low Pressure Switch
- Fuse

See notes on page 10.

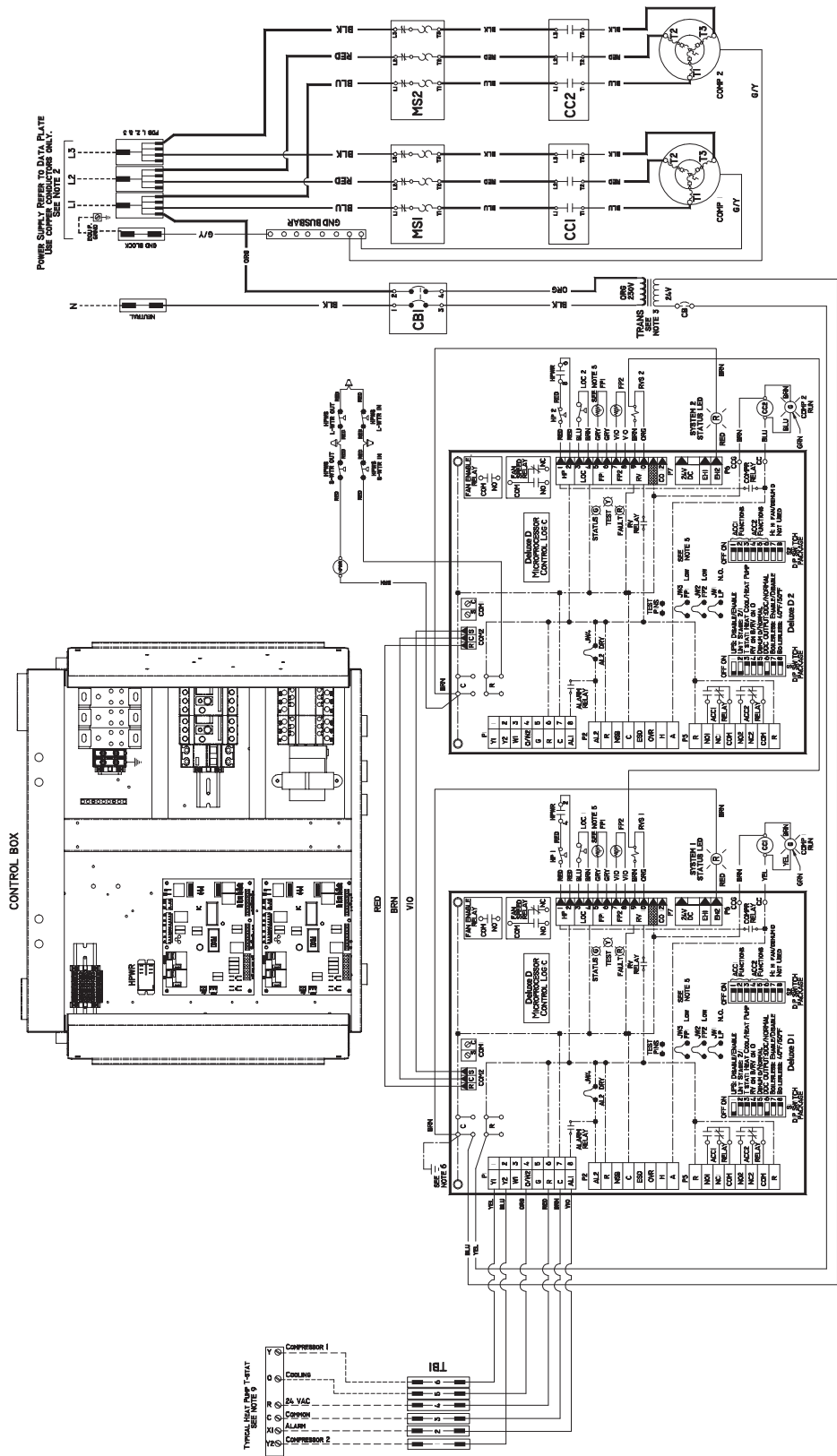

Fig. 7 — Typical Aqazone™ 50PSW360 Deluxe D Control Wiring, 3-Phase

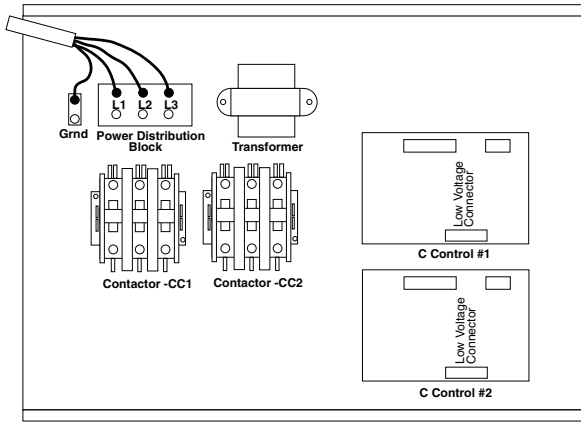

Fig. 8 — Typical Field Wiring

EXTERNAL LOOP POWER CONNECTION — If the unit is to be connected to an external loop pump or flow controller, connect the pump to the loop pump terminal block PB1. The maximum power handling is 4 amps at 240-v. The pumps will automatically cycle as required by the unit.

220-V OPERATION — All 220/240-v units are factory wired for 220-v. The transformers may be switched to 240-v operation (as illustrated on the wiring diagram) by switching the red (220-v) wire with the orange (240-v) wire at the L2 terminal.

380-VOLT OPERATION — All 380/415 volt units are factory wired for 420 volts. The transformers may be switched to 380-volt operation by switching the brown (380 volt) wire with the violet (420 volt) wire at the L1 terminal.

Step 7 — Wire Low Voltage Connections

THERMOSTAT CONNECTIONS

The thermostat should be wired directly to the Aquazone™ control board. See Fig. 4-7.

WATER FREEZE PROTECTION — The Aquazone control allows the field selection of source fluid freeze protection points through jumpers. The factory setting of jumper JW3 (FP1) is set for water at -1.1 C. In earth loop applications, jumper JW3 should be clipped to change the setting to -12.2 C when using antifreeze in colder earth loop applications. See Fig. 9.

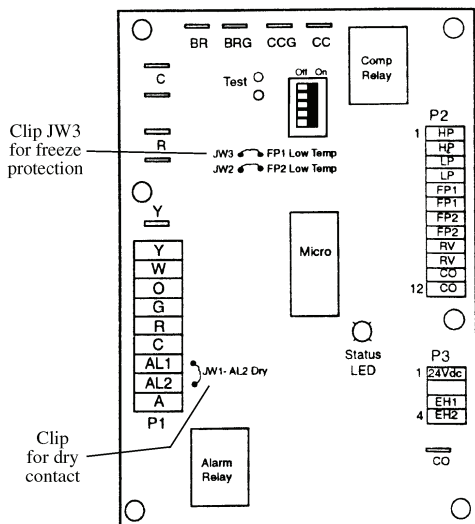

Fig. 9 — Typical Aquazone Control Board Jumper Locations (Complete C Control Shown)

ACCESSORY CONNECTIONS — The terminal labeled A on the control is provided to control accessory devices such as water valves, electronic air cleaners, humidifiers, etc. This signal operates with the compressor terminal. See Fig. 10. Refer to the specific unit wiring schematic for details.

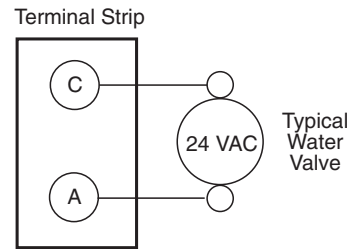

Fig. 10 — Typical Aquazone Accessory Wiring (Deluxe D Control Shown)

NOTE: The A terminal should *only* be used with 24-v signals, not line voltage signals.

IMPORTANT: Two-compressor units with Complete C or Deluxe D controls wired to terminal A will be turned off if the controls are in lockout mode, even if the other board is in normal operating mode.

WATER SOLENOID VALVES — Water solenoid valves may be used on variable flow systems and ground water installations. A typical well water control valve wiring which can limit waste water in a lockout condition is shown in Fig. 10. A slow closing valve may be required to prevent water hammer. When using a slow closing valve, special wiring conditions need to be considered. The valve takes approximately 60 seconds to open (very little water will flow before 45 seconds) and it activates the compressor only after the valve is completely opened by closing its end switch. When wired as shown, the valve will have the following operating characteristics:

1. Remain open during a lockout.
2. Draw approximately 25 to 35-va through the “Y” signal of the thermostat.

IMPORTANT: This can overheat the anticipators of electromechanical thermostats. Only use relay based electronic thermostats.

PRE-START-UP

System Checkout — When the installation is complete, follow the system checkout procedure outlined below before starting up the system. Be sure:

1. Voltage is within the utilization range specifications of the unit compressor and fan motor, and voltage is balanced for 3-phase units.
2. Fuses, breakers and wire are correct size.
3. Low voltage wiring is complete.
4. Piping and system flushing is complete.
5. Air is purged from closed loop system.
6. System is balanced as required. Monitor if necessary.
7. Isolation valves are open.
8. Water control valves or loop pumps are wired.
9. Transformer switched to lower voltage tap if necessary.
10. Service/access panels are in place.
11. Control field-selected settings are correct.

FIELD SELECTABLE INPUTS

Jumpers and DIP (dual in-line package) switches on the control board are used to customize unit operation and can be configured in the field.

IMPORTANT: Jumpers and DIP switches should only be clipped when power to control board has been turned off.

Complete C Control Jumper Settings (See Fig. 4-6)

WATER COIL FREEZE PROTECTION (FP1) LIMIT SETTING — Select jumper 3, (JW3-FP1 Low Temp) to choose FP1 limit of -12.2 C or -1.1 C . To select -1.1 C as the limit, DO NOT clip the jumper. To select -12.2 C as the limit, clip the jumper.

ALARM RELAY SETTING — Select jumper 1 (JW1-AL2 Dry) for connecting alarm relay terminal (AL2) to 24 vac (R) or to remain as a dry contact (no connection). To connect AL2 to R, do not clip the jumper. To set as dry contact, clip the jumper.

Complete C Control DIP Switches — The Complete C control has one DIP switch block with five switches. See Fig. 4-6.

PERFORMANCE MONITOR (PM) — DIP switch 1 will enable or disable this feature. To enable the PM, set the switch to ON. To disable the PM, set the switch to OFF.

STAGE 2 — DIP switch 2 will enable or disable compressor delay. Set DIP switch to OFF for Stage 2 in which the compressor will have a 3-second delay before energizing. DIP switch 3 is not used. DIP switch 4 is not used. DIP switch 5 is used to initiate one or 3 tries for the FP1 fault. If water freeze protection for the water coil is needed, then DIP switch 5 can be set to lock out on the FP1 fault after one try.

Deluxe D Control Jumper Settings (See Fig. 7)

WATER COIL FREEZE PROTECTION (FP1) LIMIT SETTING — Select jumper 3, (JW3-FP1 Low Temp) to choose FP1 limit of -12.2 C or -1.1 C . To select -1.1 C as the limit, DO NOT clip the jumper. To select -12.2 C as the limit, clip the jumper.

ALARM RELAY SETTING — Select jumper 4 (JW4-AL2 Dry) for connecting alarm relay terminal (AL2) to 24 vac (R) or to remain as a dry contact (no connection). To connect AL2 to R, do not clip the jumper. To set as dry contact, clip the jumper.

LOW PRESSURE SETTING — The Deluxe D control can be configured for Low Pressure Setting (LP). Select jumper 1 (JW1-LP Norm Open) for choosing between low pressure input normally opened or closed. To configure for normally closed operation, do not clip the jumper. To configure for normally open operation, clip the jumper.

Deluxe D Control DIP Switches — The Deluxe D control has 2 DIP switch blocks. Each DIP switch block has 8 switches and is labeled either S1 or S2 on the circuit board. See Fig. 7.

DIP SWITCH BLOCK 1 (S1) — This set of switches offers the following options for Deluxe D control configuration:

Performance Monitor (PM) — Set switch 1 to enable or disable performance monitor. To enable the PM, set the switch to ON. To disable the PM, set the switch to OFF.

Compressor Relay Staging Operation — Switch 2 will enable or disable compressor relay staging operation. The compressor relay can be set to turn on with Stage 1 or Stage 2 call from the thermostat. This setting is used with dual stage units

(units with 2 compressors and 2 Deluxe D controls) or in master/slave applications. In master/slave applications, each compressor and fan will stage according to its switch 2 setting. If switch is set to Stage 2, the compressor will have a 3-second delay before energizing during Stage 2 demand.

NOTE: If DIP switch is set for Stage 2, the alarm relay will not cycle during Test mode.

Heating/Cooling Thermostat Type — Switch 3 provides selection of thermostat type. Heat pump or heat/cool thermostats can be selected. Select OFF for heat/cool thermostats. When in heat/cool mode, Y1 is used for cooling Stage 1, Y2 is used for cooling Stage 2, W1 is used for heating Stage 1 and O/W2 is used for heating Stage 2. Select ON for heat pump applications. In heat pump mode, Y1 used is for compressor Stage 1, Y2 is used for compressor Stage 2, W1 is used for heating Stage 3 or emergency heat, and O/W2 is used for RV (heating or cooling) depending upon switch 4 setting.

O/B Thermostat Type — Switch 4 provides selection for heat pump O/B thermostats. O is cooling output. B is heating output. Select ON for heat pumps with O output. Select OFF for heat pumps with B output.

Switches 5, 6, 7, 8 — Not used.

DIP SWITCH BLOCK 2 (S2) — Used for accessory relay configurations.

Deluxe D Control Accessory Relay Configurations (See Tables 4 and 5) — The following accessory relay settings are applicable for Deluxe D control only:

CYCLE WITH COMPRESSOR — In this configuration, the relay will be ON any time the compressor relay is on.

DIGITAL NIGHT SETBACK (NSB) — In this configuration, the relay will be ON if the NSB input is connected to ground C.

NOTE: If there are no relays configured for digital NSB, then the NSB and OVR inputs are automatically configured for mechanical operation.

MECHANICAL NIGHT SETBACK — When NSB input is connected to ground C, all thermostat inputs are ignored. A thermostat setback heating call will then be connected to the OVR input. If OVR input becomes active, then the Deluxe D control will enter night low limit (NLL) staged heating mode. The NLL staged heating mode will then provide heating during the NSB period.

WATER VALVE (SLOW OPENING) — If relay is configured for water valve (slow opening), the relay will start 60 seconds prior to starting compressor relay.

⚠ CAUTION

To avoid equipment damage, DO NOT leave system filled in a building without heat during the winter unless antifreeze is added to system water. Condenser coils never fully drain by themselves and will freeze unless winterized with antifreeze.

Table 4 — DIP Switch Block S2 — Accessory 1 Relay Options

ACCESSORY 1 RELAY OPTIONS	DIP SWITCH POSITION		
	1	2	3
Digital NSB	Off	On	On
Water Valve — Slow Opening	On	Off	On

LEGEND

NSB — Night Setback

NOTE: All other DIP switch combinations are invalid.

**Table 5 — DIP Switch Block S2 —
Accessory 2 Relay Options**

ACCESSORY 2 RELAY OPTIONS	DIP SWITCH POSITION		
	4	5	6
Digital NSB	Off	On	On
Water Valve — Slow Opening	On	Off	On

LEGEND

NSB — Night Setback

NOTE: All other DIP switch combinations are invalid.

START-UP

Use the procedure outlined below to initiate proper unit start-up.

NOTE: This equipment is designed for indoor installation only.

Operating Limits (See Table 6)

ENVIRONMENT — This equipment is designed for indoor installation ONLY. Extreme variations in temperature, humidity and corrosive water or air will adversely affect the unit performance, reliability and service life.

POWER SUPPLY — A voltage variation of $\pm 10\%$ of nameplate utilization voltage is acceptable.

NOTE: These operating conditions are not normal or continuous operating conditions. It is assumed that start-up is for the purpose of bringing the building space up to occupancy temperature.

⚠ WARNING
When the disconnect switch is closed, high voltage is present in some areas of the electrical panel. Exercise caution when working with the energized equipment.

**Table 6 — 50PSW Unit Operating Limits (C)
BUILDING COMMISSIONING**

50PSW UNIT SIZE	COOLING			HEATING		
	Source Min/Max	Load Min/Max	Ambient Min/Max	Source Min/Max	Load Min/Max	Ambient Min/Max
036	10/43	16/27	7/43	-1/27	16/49	4/29
060,120	10/49	16/32	7/43	-1/27	16/49	4/29
180,360	10/32	16/32	7/43	10/21	27/49	4/29

BUILDING OPERATING

50PSW UNIT SIZE	COOLING			HEATING		
	Source Min/Max	Load Min/Max	Ambient Min/Max	Source Min/Max	Load Min/Max	Ambient Min/Max
036	10/49	10/32	7/43	-7/27	16/54	4/29
060,120	10/49	10/32	7/43	-7/27	16/54	4/29
180,360	10/43	10/32	7/43	-7/21	16/49	4/29

Unit Start-Up

1. Turn off all power to unit.
2. Adjust all valves to full open position.
3. Restore power to unit.
4. Operate each unit in the cooling cycle. See Table 6 for unit entering water temperatures.
5. Operate each heat pump in the heating cycle immediately after checking cooling cycle operation.

NOTE: A time delay will prevent the compressor from re-starting for approximately 5 minutes. The time delay function can be overridden on the Complete C control board.

6. If unit fails to operate, perform the following system checks:
 - a. Check the voltage and current. Be sure they comply with electrical data on unit nameplate.
 - b. Check for loose terminal screws where wire connections have been made on both the line and low-voltage terminal boards.
 - c. Check the supply and return piping. Be sure they are properly connected to the inlet and outlet connections on the unit.
 - d. If the checks described above fail to reveal the problem and the unit still will not operate, contact a trained service technician to ensure proper diagnosis.

Scroll Compressor Rotation — It is important to be certain compressor is rotating in the proper direction. To determine whether or not compressor is rotating in the proper direction:

1. Connect service gages to suction and discharge pressure fittings.
2. Energize the compressor.
3. The suction pressure should drop and the discharge pressure should rise, as is normal on any start-up.

If the suction pressure does not drop and the discharge pressure does not rise to normal levels:

1. Turn off power to the unit. Install disconnect tag.
2. Reverse any two of the unit power leads.
3. Reapply power to the unit and verify pressures are correct. The suction and discharge pressure levels should now move to their normal start-up levels.

⚠ CAUTION
When the compressor is rotating in the wrong direction, the unit makes an elevated level of noise and does not provide cooling. Damage to compressor will occur if allowed to operate in this manner.

After a few minutes of reverse operation, the scroll compressor internal overload protection will open, thus activating the unit lockout. This requires a manual reset. To reset, turn the thermostat on and then off.

NOTE: There is a 5-minute time delay before the compressor will start.

Flow Regulation — Flow regulation can be accomplished by two methods. Most water control valves have a flow adjustment built into the valve. By measuring the pressure drop through the unit heat exchanger, the flow rate can be determined. Adjust the water control valve until the flow of 0.09 to 0.13 L/s is achieved. Since the pressure constantly varies, two pressure gages may be needed in some applications. See Table 7 for heat exchanger pressure drops.

An alternative method is to install a flow control device. These devices are typically an orifice of plastic material designed to allow a specified flow rate that are mounted on the outlet of the water control valve. Occasionally these valves produce a velocity noise that can be reduced by applying some back pressure. To accomplish this, slightly close the leaving isolation valve of the water regulating device.

Table 7 — Heat Exchanger Pressure Drop
UNIT SIZES 036-120

50PSW UNIT SIZE	L/s	PRESSURE DROP (kPa)			
		-1 C	10 C	21 C	32 C
Source/Outdoor Coax					
036	0.28	11.7	9.0	6.9	5.5
	0.43	28.3	23.4	19.3	16.5
	0.57	49.0	41.4	35.2	31.0
060	0.47	10.3	9.0	17.2	14.5
	0.71	27.6	23.4	47.6	42.1
	0.95	47.6	42.8	88.3	80.0
120	0.95	11.7	9.7	8.3	6.2
	1.42	30.3	26.2	22.8	18.6
	1.89	52.4	46.9	42.1	34.5
Load/Outdoor Coax					
036	0.28	—	4.1	3.4	2.1
	0.43	—	9.7	9.0	7.6
	0.57	—	18.0	16.5	15.2
060	0.47	—	9.7	9.0	8.3
	0.71	—	24.1	22.1	20.7
	0.95	—	42.8	40.0	37.9
120	0.95	—	11.0	9.7	2.1
	1.42	—	26.2	24.1	22.8
	1.89	—	46.9	44.1	41.1

UNIT SIZES 180,360

50PSW UNIT SIZE	L/s	PRESSURE DROP (kPa)			
		0 C	10 C	20 C	30 C
Source/Outdoor Coax					
180	1.10	4.82	2.76	1.72	0.88
	1.67	17.92	11.72	11.38	9.47
	2.21	32.40	22.75	21.37	19.30
360	2.21	11.03	8.27	7.22	6.29
	3.34	26.88	24.82	23.10	21.29
	4.42	48.95	44.82	41.36	38.47

NOTE: Bold values indicate use of antifreeze is required.

Cleaning and Flushing — Cleaning and flushing of the piping system is the single most important step to ensure proper start-up and continued efficient operation of the system.

⚠ WARNING

To avoid possible injury or death due to electrical shock, open the power supply disconnect switch and secure it in an open position before flushing system. Install lockout tag.

Follow the instructions below to properly clean and flush the system:

1. Verify electrical power to the unit is disconnected and lockout tag installed.
2. Install the system with the supply hose connected directly to the return riser valve. Use a single length of flexible hose.
3. Open all air vents. Fill the system with the water. DO NOT allow system to overflow. Bleed all air from the system. Pressurize and check the system for leaks and repair appropriately.
4. Verify all strainers are in place. Start the pumps, and systematically check each vent to ensure all air is bled from the system.
5. Verify make-up water is available. Adjust make-up water appropriately to replace the air which was bled from the system. Check and adjust the water/air level in the expansion tank.

6. Raise the loop temperature to approximately 29.4 C. Open the drain at the lowest point in the system. Adjust the make-up water replacement rate to equal the rate of bleed.
7. Refill the system and add trisodium phosphate in a proportion of approximately 0.5 kg per 750 L of water (or other equivalent approved cleaning agent).

⚠ CAUTION

To avoid possible damage to a plastic (PVC) piping system, do not allow temperatures to exceed 43.3 C.

Raise the loop temperature to 37.8 C. Circulate the solution for a minimum of 8 to 24 hours. At the end of this period, shut off the circulating pump and drain the solution. Repeat system cleaning if desired.

8. When the cleaning process is complete, remove the short-circuited hose. Reconnect the hoses to the proper supply, and return the connections to each of the units. Refill the system and bleed off all air.
9. Test the system pH with litmus paper. The system water should be slightly alkaline (pH of 7.5 to 8.5). Add chemicals, as appropriate, to maintain acidity levels.
10. When the system is successfully cleaned, flushed, refilled and bled, restore power.
11. Check the main system panels, safety cutouts and alarms. Set the controls to properly maintain loop temperatures.

⚠ CAUTION

DO NOT use “Stop Leak” or any similar chemical agent in this system. Addition of these chemicals to the loop water will foul the system and inhibit unit operation.

Antifreeze — In areas where entering loop temperatures drop below 4.4 C or where piping will be routed through areas subject to freezing, antifreeze is needed.

Alcohols and glycols are commonly used as antifreeze agents. Freeze protection should be maintained to 8.3° C below the lowest expected entering loop temperature. For example, if the lowest expected entering loop temperature is -1.1 C, the leaving loop temperature would be -5.6 to -3.9 C. Therefore, the freeze protection should be at -9.4 C (-1.1 C - 8.3 C = -9.4 C).

IMPORTANT: All alcohols should be pre-mixed and pumped from a reservoir outside of the building or introduced under water level to prevent alcohols from fuming.

Calculate the total volume of fluid in the piping system. See Table 8. Use the percentage by volume in Table 9 to determine the amount of antifreeze to use. Antifreeze concentration should be checked from a well mixed sample using a hydrometer to measure specific gravity.

FREEZE PROTECTION SELECTION — The -1.1 C FP1 factory setting (water) should be used to avoid freeze damage to the unit.

Once antifreeze is selected, the JW3 jumper (FP1) should be clipped on the control to select the low temperature (antifreeze -12.2 C) set point to avoid nuisance faults.

Table 8 — Approximate Fluid Volume (L) per 30 M of Pipe

PIPE	DIAMETER (in.) [mm]	VOLUME (gal.) [L]
Copper	1 [25.4]	4.1 [15.5]
	1.25 [31.8]	6.4 [24.2]
	1.5 [38.1]	9.2 [34.8]
Rubber Hose	1 [25.4]	3.9 [14.8]
Polyethylene	3/4 IPS SDR11	2.8 [10.6]
	1 IPS SDR11	4.5 [17.0]
	1 1/4 IPS SDR11	8.0 [30.8]
	1/2 IPS SDR11	10.9 [41.3]
	2 IPS SDR11	18.0 [68.1]
	1 1/4 IPS SCH40	8.3 [31.4]
	1 1/2 IPS SCH40	10.9 [41.3]
2 IPS SCH40	17.0 [64.4]	

LEGEND

- IPS** — Internal Pipe Size
- SCH** — Schedule
- SDR** — Standard Dimensional Ratio

NOTE: Volume of heat exchanger is approximately 1.0 gallon (3.78 liters).

Table 9 — Antifreeze Percentages by Volume

ANTIFREEZE	MINIMUM TEMPERATURE FOR FREEZE PROTECTION (C)			
	-12.2	-9.4	-6.7	-3.9
Methanol (%)	25	21	16	10
100% USP Food Grade Propylene Glycol (%)	38	30	22	15
Ethanol (%)	29	25	20	14

Cooling Tower/Boiler Systems — These systems typically use a common loop maintained at 15.6 to 32.2 C. The use of a closed circuit evaporative cooling tower with a secondary heat exchanger between the tower and the water loop is recommended. If an open type cooling tower is used continuously, chemical treatment and filtering will be necessary.

Ground Coupled, Closed Loop and Plateframe Heat Exchanger Well Systems — These systems allow water temperatures from -1.1 to 43.3 C. The external loop field is divided up into 51 mm polyethylene supply and return lines. Each line has valves connected in such a way that upon system start-up, each line can be isolated for flushing using only the system pumps. Air separation should be located in the piping system prior to the fluid re-entering the loop field.

OPERATION

Power Up Mode — The unit will not operate until all the inputs, terminals and safety controls are checked for normal operation.

NOTE: The compressor will have a 5-minute anti-short cycle upon power up.

Units with Aquazone™ Complete C Control

STANDBY — The Y and W terminals are not active in Standby mode, however the O and G terminals may be active, depending on the application. The compressor will be off.

COOLING — The Y and O terminals are active in Cooling mode. After power up, the first call to the compressor will initiate a 5 to 80 second random start delay and a 5-minute anti-short cycle protection time delay. After both delays are complete, the compressor is energized.

NOTE: On all subsequent compressor calls the random start delay is omitted.

HEATING STAGE 1 — Terminal Y is active in heating Stage 1. After power up, the first call to the compressor will initiate a 5 to 80 second random start delay and a 5-minute anti-short cycle protection time delay. After both delays are complete, the compressor is energized.

NOTE: On all subsequent compressor calls the random start delay is omitted.

HEATING STAGE 2 — To enter Stage 2 mode, terminal W is active (Y is already active). Also, the G terminal must be active or the W terminal is disregarded.

Units with Aquazone Deluxe D Control

STANDBY — The compressor will be off. The reversing valve (RV) relays will be on if inputs are present.

HEATING STAGE 1 — In Heating Stage 1 mode, the fan enable and compressor relays are turned on immediately. Once the demand is removed, the relays are turned off and the control reverts to standby mode. If there is a master/slave or dual compressor application, all compressor relays and related functions will operate per their associated DIP switch 2 setting on S1.

HEATING STAGE 2 — In Heating Stage 2 mode, the compressor relays remain on. The control reverts to Heating Stage 1 mode once demand is removed. If there is a master/slave or dual compressor application, all compressor relays and related functions will operate per their associated DIP switch 2 setting on S1.

COOLING STAGE 1 — In Cooling Stage 1 mode, the compressor and RV relays are turned on immediately. If configured as stage 2 (DIP switch set to OFF) then the compressor and fan will not turn on until there is a stage 2 demand. The compressor relays are turned off immediately when the Cooling Stage 1 demand is removed. The control reverts to standby mode. The RV relay remains on until there is a heating demand. If there is a master/slave or dual compressor application, all compressor relays and related functions will track with their associated DIP switch 2 on S1.

COOLING STAGE 2 — In Cooling Stage 2 mode, the compressor and RV relays remain on. The control reverts to Cooling Stage 1 mode once the demand is removed. If there is a master/slave or dual compressor application, all compressor relays and related functions will track with their associated DIP switch 2 on S1.

NIGHT LOW LIMIT (NLL) STAGED HEATING — In NLL staged heating mode, the override (OVR) input becomes active and is recognized as a call for heating and the control will immediately go into a Heating Stage 1 mode. With an additional 30 minutes of NLL demand, the control will go into Heating Stage 2 mode. With another additional 30 minutes of NLL demand, the control will go into Heating Stage 3 mode.

SYSTEM TEST

System testing provides the ability to check the control operation. The control enters a 20-minute Test mode by momentarily shorting the test pins. All time delays are increased 15 times. See Fig. 11.

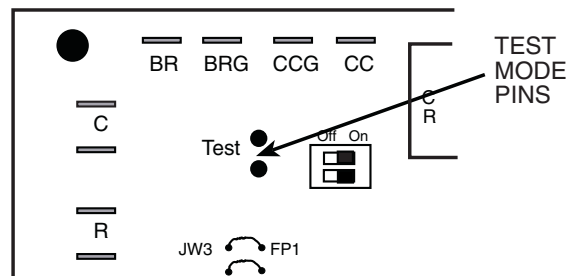

Fig. 11 — Test Mode Pins Location

Test Mode — Enter the Test mode on Complete C or Deluxe D controls by momentarily shorting the test terminals. The Complete C or Deluxe D control will enter a 20-minute test mode period in which all time delays are sped up 15 times.

Upon entering Test mode, the status LED (light-emitting diode) will flash a code representing the last fault. For diagnostic ease at the thermostat, the alarm will also cycle during Test mode. The alarm relay will cycle on and off similar to the status LED to indicate a code representing the last fault, at the thermostat. Test mode can be exited by shorting the test terminals for 3 seconds. See Tables 10-12.

NOTE: Deluxe D control has a flashing code and alarm relay cycling code that will both have the same numerical label. For example, flashing code 1 will have an alarm relay cycling code 1. Code 1 indicates the control has not faulted since the last power off to power on sequence.

Retry Mode — In Retry mode, the status LED will start to flash slowly to signal that the control is trying to recover from an input fault. The control will stage off the outputs and try to again satisfy the thermostat used at terminal Y. Once the thermostat input calls are satisfied, the control will continue normal operation.

NOTE: If 3 consecutive faults occur without satisfying the thermostat input call to terminal Y, the control will go into lockout mode. The last fault causing the lockout is stored in memory and can be viewed by entering Test mode.

Table 10 — Complete C Control Current LED Status and Alarm Relay Operations

LED STATUS	DESCRIPTION OF OPERATION	ALARM RELAY
On	Normal Mode	Open
	Normal Mode with PM Warning	Cycle (Closed 5 sec., Open 25 sec.)
Off	Control is non-functional	Open
Slow Flash	Fault Retry	Open
	Over/Under Voltage Shutdown	Open (Closed after 15 minutes)
Fast Flash	Lockout	Closed
Flashing Code 1	Test Mode — No fault in memory	Cycling Code 1
Flashing Code 2	Test Mode — HP Fault in memory	Cycling Code 2
Flashing Code 3	Test Mode — LP Fault in memory	Cycling Code 3
Flashing Code 4	Test Mode — FP1 Fault in memory	Cycling Code 4
Flashing Code 5	Test Mode — FP2 Fault in memory	Cycling Code 5
Flashing Code 7	Test Mode — Over/Under shutdown in memory	Cycling Code 7
Flashing Code 8	Test Mode — PM in memory	Cycling Code 8
Flashing Code 9	Test Mode — FP1/FP2 swapped fault in memory	Cycling Code 9

LEGEND

- FP — Freeze Protection
- HP — High Pressure
- LED — Light-Emitting Diode
- LP — Low Pressure
- PM — Performance Monitor

NOTES:

1. Slow flash is 1 flash every 2 seconds.
2. Fast flash is 2 flashes every 1 second.
3. EXAMPLE: "Flashing Code 2" is represented by 2 fast flashes followed by a 10-second pause. This sequence will repeat continually until the fault is cleared.

Aquazone™ Deluxe D Control LED Indicators — There are 3 LED indicators on the Deluxe D control:

STATUS LED — Status LED indicates the current status or mode of the Deluxe D control. The Status LED light is green.

TEST LED — Test LED will be activated any time the Deluxe D control is in Test mode. The Test LED light is yellow.

FAULT LED — Fault LED light is red. The fault LED will always flash a code representing the last fault in memory. If there is no fault in memory, the fault LED will flash code 1 on the display and appear as 1 fast flash alternating with a 10-second pause. See Table 12.

Table 11 — Complete C Control LED Code and Fault Descriptions

LED CODE	FAULT	DESCRIPTION
1	No fault in memory	There has been no fault since the last power-down to power-up sequence
2	High-Pressure Switch	HP Open Instantly
3	Low-Pressure Switch	LP open for 30 continuous seconds before or during a call (bypassed for first 60 seconds)
4	Freeze Protection (Source) Coax — FP1	FP1 below Temp limit for 30 continuous seconds (bypassed for first 60 seconds of operation)
5	Freeze Protection (Load) Coil — FP2	FP2 below Temp limit for 30 continuous seconds (bypassed for first 60 seconds of operation)
7 (Autoreset)	Over/Under Voltage Shutdown	"R" power supply is <19 vac or >30 vac
8	PM Warning	Performance Monitor Warning has occurred.
9	FPI and FP2 Thermistors are swapped	FP1 temperature is higher than FP2 in heating/test mode, or FP2 temperature is higher than FP1 in cooling/test mode.

LEGEND

- FP — Freeze Protection
- HP — High Pressure
- LP — Low Pressure

Table 12 — Aquazone™ Deluxe D Control Current LED Status and Alarm Relay Operations

DESCRIPTION	STATUS LED (Green)	TEST LED (Yellow)	FAULT LED (Red)	ALARM RELAY
Normal Mode	On	Off	Flash Last Fault Code in Memory	Open
Normal Mode with PM	On	Off	Flashing Code 8	Cycle (closed 5 sec, open 25 sec, ...)
Control is Non-Functional	Off	Off	Off	Open
Test Mode	—	On	Flash Last Fault Code in Memory	Cycling Appropriate Code
Night Setback	Flashing Code 2	—	Flash Last Fault Code in Memory	—
ESD	Flashing Code 3	—	Flash Last Fault Code in Memory	—
Invalid T-stat Inputs	Flashing Code 4	—	Flash Last Fault Code in Memory	—
No Fault in Memory	On	Off	Flashing Code 1	Open
HP Fault	Slow Flash	Off	Flashing Code 2	Open
LP Fault	Slow Flash	Off	Flashing Code 3	Open
FP1 Fault	Slow Flash	Off	Flashing Code 4	Open
FP2 Fault	Slow Flash	Off	Flashing Code 5	Open
CO Fault	Slow Flash	Off	Flashing Code 6	Open
Over/Under Voltage	Slow Flash	Off	Flashing Code 7	Open (closed after 15 minutes)
HP Lockout	Fast Flash	Off	Flashing Code 2	Closed
LP Lockout	Fast Flash	Off	Flashing Code 3	Closed
FP1 Lockout	Fast Flash	Off	Flashing Code 4	Closed
FP2 Lockout	Fast Flash	Off	Flashing Code 5	Closed
CO Lockout	Fast Flash	Off	Flashing Code 6	Closed

LEGEND

- CO — Condensate Overflow
- ESD — Emergency Shutdown
- FP — Freeze Protection
- HP — High Pressure
- LP — Low Pressure
- PM — Performance Monitor

NOTES:

1. If there is no fault in memory, the Fault LED will flash code 1.
2. Codes will be displayed with a 10-second Fault LED pause.
3. Slow flash is 1 flash every 2 seconds.
4. Fast flash is 2 flashes every 1 second.
5. EXAMPLE: "Flashing Code 2" is represented by 2 fast flashes followed by a 10-second pause. This sequence will repeat continually until the fault is cleared.

SERVICE

Perform the procedures outlined below periodically, as indicated.

IMPORTANT: When a compressor is removed from this unit, system refrigerant circuit oil will remain in the compressor. To avoid leakage of compressor oil, the refrigerant lines of the compressor must be sealed after it is removed.

IMPORTANT: To avoid the release of refrigerant into the atmosphere, the refrigerant circuit of this unit must only be serviced by technicians which meet local, state and federal proficiency requirements.

IMPORTANT: All refrigerant discharged from this unit must be recovered without exception. Technicians must follow industry accepted guidelines and all local, state and federal statutes for the recovery and disposal of refrigerants.

⚠ WARNING

To prevent injury or death due to electrical shock or contact with moving parts, open unit disconnect switch before servicing unit.

Water Coil — Keep all air out of the water coil. Check open loop systems to be sure the well head is not allowing air to infiltrate the water line. Always keep lines airtight.

Inspect heat exchangers regularly, and clean more frequently if the unit is located in a "dirty" environment. The heat exchanger should be kept full of water at all times. Open loop systems should have an inverted P trap placed in the discharge line to keep water in the heat exchanger during off cycles. Closed loop systems must have a minimum of 103 kPa during the summer and 276 kPa during the winter.

Check P trap frequently for proper operation.

⚠ CAUTION

To avoid fouled machinery and extensive unit clean-up, DO NOT operate units without filters in place. DO NOT use equipment as a temporary heat source during construction.

Refrigerant System — Verify air and water flow rates are at proper levels before servicing. To maintain sealed circuitry integrity, do not install service gages unless unit operation appears abnormal.

Condenser Cleaning — Water-cooled condensers may require cleaning of scale (water deposits) due to improperly maintained closed-loop water systems. Sludge build-up may need to be cleaned in an open water tower system due to induced contaminants.

Local water conditions may cause excessive fouling or pitting of tubes. Condenser tubes should therefore be cleaned at least once a year, or more often if the water is contaminated.

Proper water treatment can minimize tube fouling and pitting. If such conditions are anticipated, water treatment analysis is recommended. Refer to the Carrier System Design Manual, Part 5, for general water conditioning information.

⚠ CAUTION

Follow all safety codes. Wear safety glasses and rubber gloves when using inhibited hydrochloric acid solution. Observe and follow acid manufacturer's instructions.

Clean condensers with an inhibited hydrochloric acid solution. The acid can stain hands and clothing, damage concrete, and, without inhibitor, damage steel. Cover surroundings to guard against splashing. Vapors from vent pipe are not harmful,

but take care to prevent liquid from being carried over by the gases.

Warm solution acts faster, but cold solution is just as effective if applied for a longer period.

GRAVITY FLOW METHOD — Do not add solution faster than vent can exhaust the generated gases.

When condenser is full, allow solution to remain overnight, then drain condenser and flush with clean water. Follow acid manufacturer's instructions. See Fig. 12.

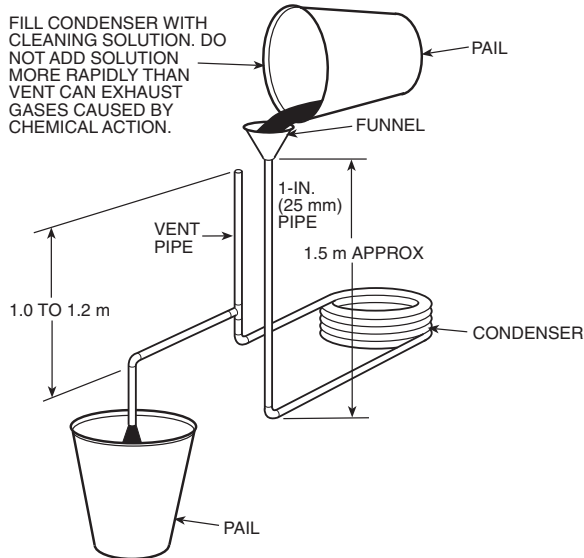

Fig. 12 — Gravity Flow Method

FORCED CIRCULATION METHOD — Fully open vent pipe when filling condenser. The vent may be closed when condenser is full and pump is operating. See Fig. 13.

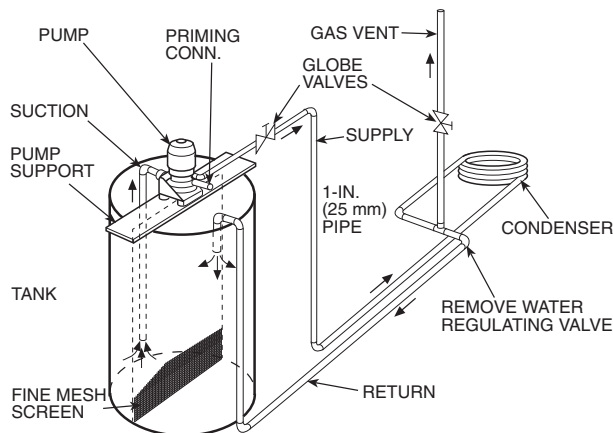

Fig. 13 — Forced Circulation Method

Regulate flow to condenser with a supply line valve. If pump is a nonoverloading type, the valve may be fully closed while pump is running.

For average scale deposit, allow solution to remain in condenser overnight. For heavy scale deposit, allow 24 hours. Drain condenser and flush with clean water. Follow acid manufacturer's instructions.

Checking System Charge — Units are shipped with full operating charge. If recharging is necessary:

1. Insert thermometer bulb in insulating rubber sleeve on liquid line near filter drier. Use a digital thermometer for all temperature measurements. **DO NOT** use a mercury or dial-type thermometer.
2. Connect pressure gage to discharge line near compressor.

3. After unit conditions have stabilized, read head pressure on discharge line gage.

NOTE: Operate unit a minimum of 15 minutes before checking charge. From standard field-supplied Pressure-Temperature chart for R-410A, find equivalent saturated condensing temperature.

4. Read liquid line temperature on thermometer; then subtract from saturated condensing temperature. The difference equals subcooling temperature.

Refrigerant Charging

WARNING

To prevent personal injury, wear safety glasses and gloves when handling refrigerant. Do not overcharge system — this can cause compressor flooding.

NOTE: Do not vent or depressurize unit refrigerant to atmosphere. Remove and recover refrigerant following accepted practices.

TROUBLESHOOTING

When troubleshooting problems with a WSHP, refer to Table 13.

Thermistor — A thermistor may be required for single-phase units where starting the unit is a problem due to low voltage. See Fig. 14 for thermistor nominal resistance.

Control Sensors — The control system employs 2 nominal 10,000 ohm thermistors (FP1 and FP2) that are used for freeze protection. Be sure FP1 is located in the discharge fluid and FP2 is located in the air discharge. See Fig. 15.

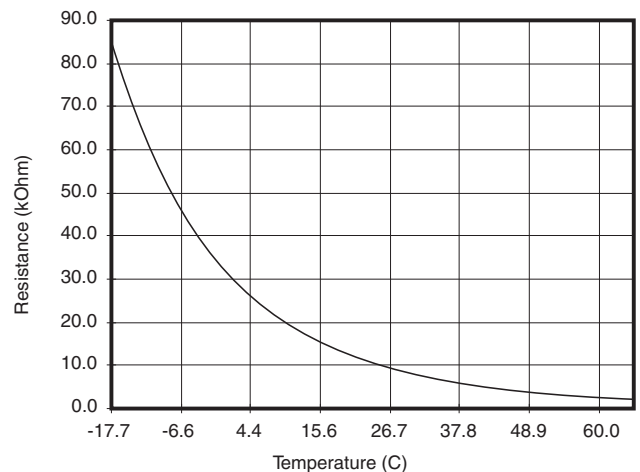

Fig. 14 — Thermistor Nominal Resistance

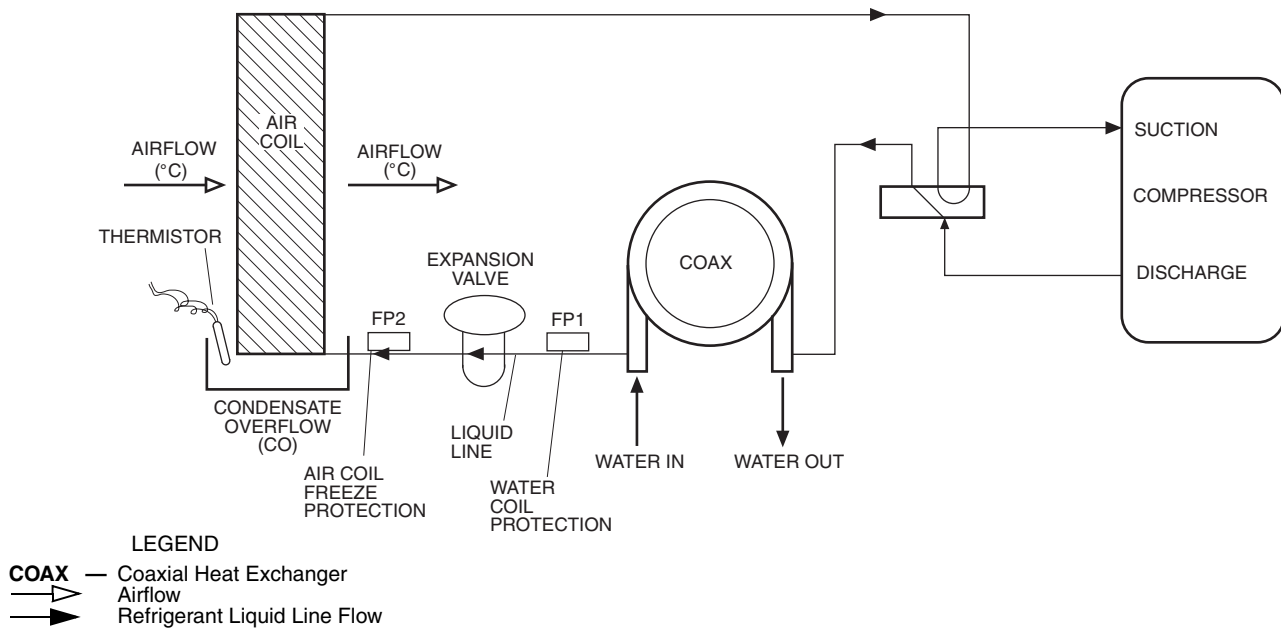

Fig. 15 — FP1 and FP2 Thermistor Location

Table 13 — Troubleshooting

FAULT	HEATING	COOLING	POSSIBLE CAUSE	SOLUTION		
Main Power Problems	X	X	Green Status LED Off	Check line voltage circuit breaker and disconnect.		
				Check for line voltage between L1 and L2 on the contactor.		
				Check for 24-vac between R and C on controller.		
				Check primary/secondary voltage on transformer.		
HP Fault — Code 2 High Pressure		X	Reduced or no water flow in cooling	Check pump operation or valve operation/setting. Check water flow adjust to proper flow rate.		
		X	Water temperature out of range in cooling	Bring water temperature within design parameters.		
	X	X	Overcharged with refrigerant	Check superheat/subcooling vs. typical operating condition.		
	X	X	Bad HP switch	Check switch continuity and operation. Replace.		
LP/LOC Fault — Code 3 Low Pressure/Loss of Charge	X	X	Insufficient charge	Check for refrigerant leaks.		
	X		Compressor pump down at start-up	Check charge and start-up water flow.		
FP1 Fault — Code 4 Source Water Freeze Protection	X		Reduced or no water flow in heating	Check pump operation or water valve operation/setting. Plugged strainer or filter. Clean or replace. Check water flow adjust to proper flow rate.		
		X		Inadequate antifreeze level	Check antifreeze density with hydrometer.	
		X		Improper freeze protect setting (-1.1 C vs -12.2 C)	Clip JW3 jumper for antifreeze (-12.2 C) use.	
	X		Water temperature out of range	Bring water temperature within design parameters.		
	X	X	Bad thermistor	Check temperature and impedance correlation.		
	FP2 Fault — Code 5 Load Coil Freeze Protection		X	Reduced or no water flow in heating	Check pump operation or water valve operation/setting. Plugged strainer or filter. Clean or replace. Check water flow adjust to proper flow rate.	
		X	Improper freeze protect setting (-1.1 C vs -12.2 C)	Clip JW3 jumper for antifreeze (-12.2 C) use.		
		X	Water temperature out of range	Bring water temperature within design parameters.		
X		X	Bad thermistor	Check temperature and impedance correlation.		
Over/Under Voltage — Code 7 (Auto Resetting)	X	X	Under voltage	Check power supply and 24-vac voltage before and during operation. Check power supply wire size. Check compressor starting. Check 24-vac and unit transformer tap for correct power supply voltage.		
				X	X	Over voltage
	X		Heating mode FP2>51.7 C			
		X	Cooling mode FP1>51.7 C OR FP2< 4.4 C	Check for poor water flow or airflow.		
No Fault Code Shown	X	X	No compressor operation	See scroll compressor rotation section.		
	X	X	Compressor overload	Check and replace if necessary.		
	X	X	Control board	Reset power and check operation.		
Unit Short Cycles	X	X	Unit in Test mode	Reset power or wait 20 minutes for auto exit.		
	X	X	Unit selection	Unit may be oversized for space. Check sizing for actual load of space.		
	X	X	Compressor overload	Check and replace if necessary.		
Unit Does Not Operate in Cooling		X	Reversing valve	Set for cooling demand and check 24-vac on RV coil and at control. If RV is stuck, run high pressure up by reducing water flow and while operating engage and disengage RV coil voltage to push valve.		
		X	Thermostat setup	Check for 'O' RV setup not 'B'.		
		X	Thermostat wiring	Check O wiring at heat pump. Jumper O and R for RV coil.		
Insufficient Capacity/ Not Cooling or Heating Properly	X	X	Low refrigerant charge	Check superheat and subcooling.		
	X	X	Restricted metering device	Check superheat and subcooling. Replace.		
		X	Defective reversing valve	Perform RV touch test.		
	X	X	Thermostat improperly located	Check location and for air drafts behind thermostat.		
	X	X	Unit undersized	Recheck loads and sizing. Check sensible cooling load and heat pump capacity.		
	X	X	Scaling in water heat exchanger	Perform scaling check and clean if necessary.		
	X	X	Inlet water too hot or cold	Check load, loop sizing, loop backfill, ground moisture.		
High Head Pressure		X	Scaling in water heat exchanger	Perform scaling check and clean if necessary.		
	X	X	Unit overcharged	Check superheat and subcooling. Reweigh in charge.		
	X	X	Non-condensables in system	Vacuum system and reweigh in charge.		
	X	X	Restricted metering device	Check superheat and subcooling. Replace.		
Low Suction Pressure	X		Reduced water flow in heating	Check pump operation or water valve operation/setting. Plugged strainer or filter. Clean or replace. Check water flow adjust to proper flow rate.		
		X			Water temperature out of range	Bring water temperature within design parameters.

LEGEND

- FP — Freeze Protection
- HP — High Pressure
- LED — Light-Emitting Diode
- LOC — Loss of Charge
- LP — Low Pressure
- RV — Reversing Valve

**50PSW
START-UP CHECKLIST**

CUSTOMER: _____ JOB NAME: _____
MODEL NO.: _____ SERIAL NO.: _____ DATE: _____
LOOP TYPE: _____ ANTIFREEZE TYPE AND %: _____

I. PRE-START-UP

DOES THE UNIT VOLTAGE CORRESPOND WITH THE SUPPLY VOLTAGE AVAILABLE? (Y/N) _____
HAVE THE POWER AND CONTROL WIRING CONNECTIONS BEEN MADE AND TERMINALS TIGHT? (Y/N) _____
HAVE WATER CONNECTIONS BEEN MADE AND IS FLUID AVAILABLE AT HEAT EXCHANGER? (Y/N) _____
HAS PUMP BEEN TURNED ON AND ARE ISOLATION VALVES OPEN? (Y/N) _____
HAS CONDENSATE CONNECTION BEEN MADE AND IS A TRAP INSTALLED? (Y/N) _____
IS AN AIR FILTER INSTALLED? (Y/N) _____

II. START-UP

IS FAN OPERATING WHEN COMPRESSOR OPERATES? (Y/N) _____
IF 3-PHASE SCROLL COMPRESSOR IS PRESENT, VERIFY PROPER ROTATION PER INSTRUCTIONS. (Y/N) _____

UNIT VOLTAGE — COOLING OPERATION

PHASE AB VOLTS _____	PHASE BC VOLTS _____ (if 3 phase)	PHASE CA VOLTS _____ (if 3 phase)
PHASE AB AMPS _____	PHASE BC AMPS _____ (if 3 phase)	PHASE CA AMPS _____ (if 3 phase)

CONTROL VOLTAGE

IS CONTROL VOLTAGE ABOVE 21.6 VOLTS? (Y/N) _____.
IF NOT, CHECK FOR PROPER TRANSFORMER CONNECTION.

TEMPERATURES

FILL IN THE ANALYSIS CHART ATTACHED.

COAXIAL HEAT EXCHANGER	COOLING CYCLE:	FLUID IN _____ C	FLUID OUT _____ C	_____ KPA	_____ FLOW
	HEATING CYCLE:	FLUID IN _____ C	FLUID OUT _____ C	_____ KPA	_____ FLOW
AIR COIL	COOLING CYCLE:	AIR IN _____ C	AIR OUT _____ C		
	HEATING CYCLE:	AIR IN _____ C	AIR OUT _____ C		

HEATING AND COOLING CYCLE ANALYSIS

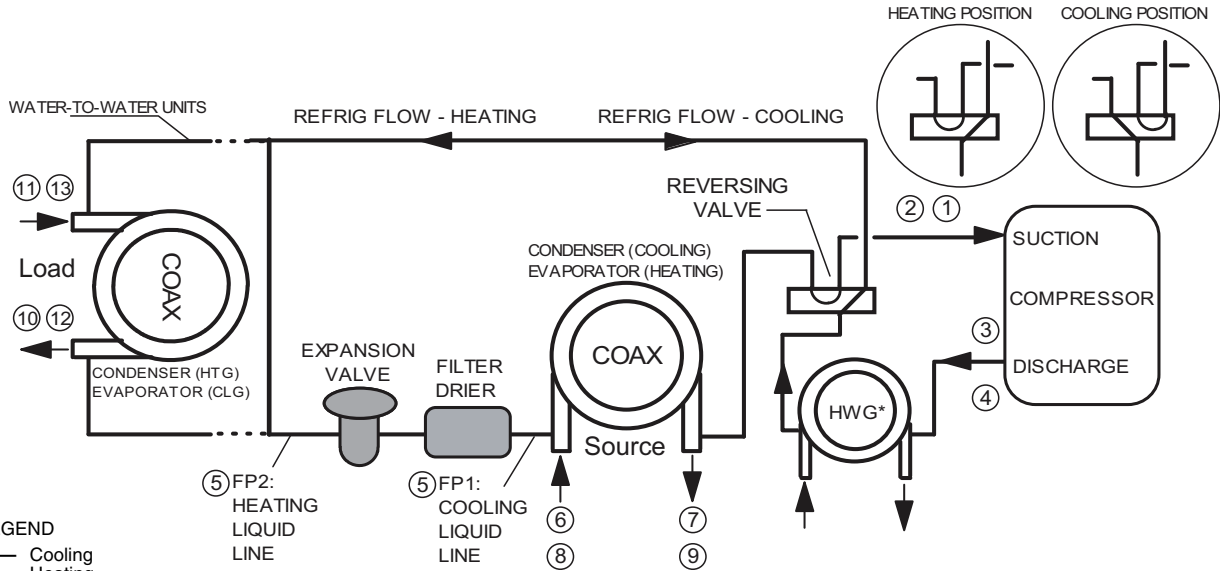

LEGEND
CLG — Cooling
HTG — Heating

*Turn off HWG (hot water generator) before troubleshooting.

DESCRIPTION	HEATING	COOLING	NOTES
Voltage			
Compressor Amp			
1 Suction Temperature			
2 Suction Pressure			
2a Saturation Temperature			
2b Superheat			
3 Discharge Temperature			
4 Discharge Pressure			
4a Saturation Temperature			
4b Subcooling			
5 Liquid Line Temperature			
6 Source Water In Temperature			
7 Source Water Out Temperature			Temperature Difference —
8 Source Water In Pressure			
9 Source Water Out Pressure			
9a Pressure Drop			
9b Flow Rate (L/s)			
10 Load Water In Temperature			
11 Load Water Out Temperature			Temperature Difference —
12 Load Water In Pressure			
13 Load Water Out Pressure			
13a Pressure Drop			
13b Flow Rate (gpm)			

HEAT OF EXTRACTION (ABSORPTION) OR HEAT OF REJECTION =
 _____ FLOW RATE (L/s) x _____ TEMP. DIFF. (DEG C) x _____ FLUID FACTOR* = _____ (kW)

SUPERHEAT = SUCTION TEMPERATURE – SUCTION SATURATION TEMPERATURE
 = _____ (DEG C)

SUBCOOLING = DISCHARGE SATURATION TEMPERATURE – LIQUID LINE TEMPERATURE
 = _____ (DEG C)

*Use 500 for water, 485 for antifreeze.

CUT ALONG DOTTED LINE

Free Manuals Download Website

<http://myh66.com>

<http://usermanuals.us>

<http://www.somanuals.com>

<http://www.4manuals.cc>

<http://www.manual-lib.com>

<http://www.404manual.com>

<http://www.luxmanual.com>

<http://aubethermostatmanual.com>

Golf course search by state

<http://golfingnear.com>

Email search by domain

<http://emailbydomain.com>

Auto manuals search

<http://auto.somanuals.com>

TV manuals search

<http://tv.somanuals.com>