

**COMPACT POWER™**

---

**BOXER**

**BIG POWER IN ALL PLACES**

**Part No. 999-823  
Serial No.s 005 and Higher**

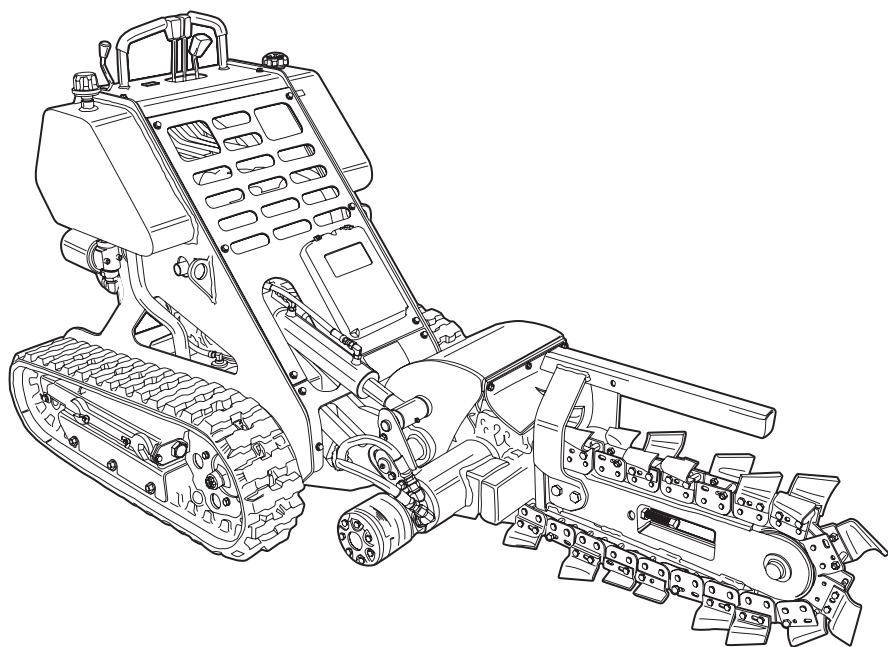

## **118 Operator's Manual**

# 118 Operator's Manual

Write your machine's Serial Number in the space below for future reference. The serial number is located on the metal tag on the left side of the machine. Remove the service access panel to locate the Serial Number plate.

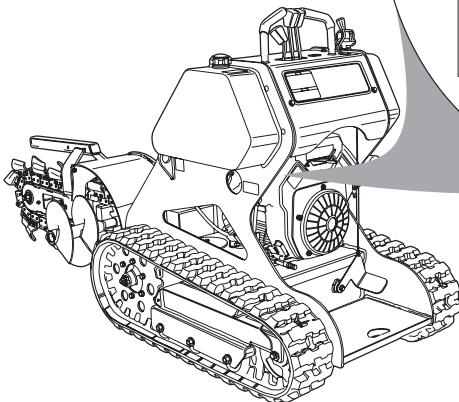

 <b>MANUFACTURED BY:</b> MERTZ MANUFACTURING LLC PONCA CITY, OKLAHOMA, USA		
DATE OF MANUFACTURE	<input type="text"/>	
MODEL NO.	<input type="text"/>	S.N. <input type="text"/>
ENGINE SERIAL NO.	<input type="text"/>	
WEIGHT	<input type="text"/> LB	<input type="text"/> KG
POWER	<input type="text"/> HP	<input type="text"/> KW
COMPACT POWER EQUIPMENT 900-478-9873 cp@equipment.com		

Record SERIAL Number here





# Boxer Product Warranty

---

## WARRANTY AND LIABILITY LIMITATIONS

Mertz Manufacturing, LLC warrants each new Compact Utility Trencher manufactured (hereinafter referred to as the equipment) by us to be free from defects in materials and workmanship, for a period of one (1) year or 1000 operational hours, whichever occurs first from the date of delivery. This warranty is effective provided that the equipment warranted hereunder is operated by the purchaser in accordance with generally approved practices, is properly maintained in accordance with the instructions contained in this owner's manual, and is operated within the manufacturer's rated capacity limitations.

Any parts of the equipment found to be defective within the warranty period shall be repaired or replaced, at Mertz Manufacturing, LLC's sole option. Repairs must be performed at Mertz Manufacturing, LLC facilities or at an authorized dealer facility. Any part or parts proving defective within the above specified time will be repaired or replacement parts furnished, F.O.B. Ponca City, Oklahoma, providing such parts are returned, transportation prepaid, and found to be defective by the manufacturer.

The purchaser is responsible to keep maintenance records to substantiate proper maintenance. If a defect becomes apparent, it is the purchaser's responsibility to notify Mertz Manufacturing, LLC or an authorized dealer of said defect. The purchaser agrees to return the defective equipment or parts to Mertz Manufacturing, LLC or to an authorized dealer facility, freight prepaid, within fifteen (15) days after the defective condition is discovered.

All warranties, if any, extended to Mertz Manufacturing, LLC by manufacturers and suppliers of component parts, accessories, or other goods included in the manufacturing of Mertz Manufacturing, LLC products will be assigned, if contractually permitted, to the purchaser. Specific component warranty details will be provided to the purchaser upon request.

This warranty excludes the following: maintenance items including, but not limited to, seals, track grousers, roller bearings, filters and spark plugs, equipment that has been repaired, replaced, or altered by someone other than Mertz Manufacturing, LLC or an authorized service facility without prior approval from Mertz Manufacturing, LLC unless, however; if Mertz Manufacturing, LLC, in its sole opinion, determines that the defective condition of the equipment was in no way caused by or was attributable to said repairs, replacements, or alternatives.

Mertz Manufacturing, LLC and the purchaser agree that, in consideration of the above expressed warranty, all other warranties other than title, either expressed or implied, whether arising under law or equity including warranties of merchant ability and fitness for a particular purpose are excluded from this contract, further, the foregoing warranty is made solely to the first purchaser and may not be transferred in any form.

The sole liability of Mertz Manufacturing, LLC and the exclusive remedy of the purchaser arising out of the manufacture, sale, or use of the equipment provided

---

hereunder, on warranties or otherwise, shall be limited to the cost of repair or replacement of defective parts as herein specified. Further Mertz Manufacturing, LLC's maximum liability hereunder arising from any cause whatsoever, including but not limited to, breach of contract or tort (including negligence), shall not exceed the contract price of the equipment furnished hereunder. Mertz Manufacturing, LLC shall not be responsible for work done, equipment or parts furnished, or for parts or repairs made by others unless the work is specifically ordered by Mertz Manufacturing, LLC. In no event shall Mertz Manufacturing, LLC be liable for removing defective parts or for reinstalling said parts when repaired or replaced by anyone other than Mertz Manufacturing, LLC or an authorized service facility or for any costs incurred with such removal or reinstallation.

### **CONSEQUENTIAL DAMAGES**

Notwithstanding any other provision of this agreement, in no event shall Mertz Manufacturing, LLC be liable, whether arising under contract, tort (including negligence) or otherwise, for loss of anticipated profits, loss of use of capital or revenue, non-operational expenses, increased expense of operation cost of purchased or replacement equipment, damage to loads or contents of the equipment, transportation expenses due to repairs, claims of customers, cost of money, or for any special, incidental or consequential loss or damage of any nature arising at any time or from any cause whatsoever.

This Warranty Agreement shall be governed by, and construed and enforced in accordance with the laws of the State of Oklahoma. Any litigation under this warranty will be held in Kay County in accordance with the laws of Oklahoma.

Mertz Manufacturing, LLC P.O. Box 150 Ponca City, OK 74602

PO BOX 150 (74602) / 1701 N WAVERLY / PONCA CITY, OK 74601. PHONE:  
(580) 762-5646 / FAX: (580) 767-8411 / NT FAX: (580) 765-3934  
[www.boxerok.com](http://www.boxerok.com)

---

# TRACK LIMITED PRORATED WARRANTY POLICY STATEMENT

---

Compact Power Inc provides a limited warranty to the original purchaser that the original tracks used on consumer products sold by Compact Power or its authorized Distributor/Dealer, and manufactured by its subsidiary Mertz Mfg., will be free from defects in material and workmanship for a period of one (1) year after the date of purchase or 400 hours of use, whichever occurs first. Compact Power or its authorized Distributor/Dealer will replace any track found to be defective in either material or workmanship, using the below described prorated discount structure, and subject to the conditions, limitations, and exclusions set forth herein.

The one year or 400 hours of use duration of this warranty applies only if the product is put to ordinary and reasonable use.

Genuine manufacturer supplied replacement track(s) not purchased with the original product purchase, but which are later purchased and used with that product, are warranted to be free from defects in material and workmanship for a period of sixty (60) days after the date of the "parts" purchase or 100 hours of use. The purchaser of these replacement tracks must be able to document the time frame and hours of use for the replacement tracks. Compact Power or its authorized Distributor/Dealer will repair or replace any such track free of charge during that period.

**Prorated discount structure:** If the original track becomes unserviceable within the first 100 hours of use, Compact Power or its authorized Distributor/Dealer will replace that track at no cost including replacement labor. If the original track becomes unserviceable within the first 200 hours of use, Compact Power or its authorized Distributor/Dealer will replace the track with a prorated discount from the cost of the track and no charge for the replacement labor. If the track becomes unserviceable within the first 400 hours of use, Compact Power or its authorized Distributor/Dealer will replace the track with a prorated discount from the cost of the track with no replacement labor paid.

## **This warranty is subject to the following conditions, limitations, and exclusions:**

### **This warranty is valid only if the following conditions are met:**

The warranty registration card must be completed and returned to manufacturer of the product.

The purchaser must perform maintenance and minor adjustments explained in the owner's manual.

The purchaser must promptly notify Compact Power or its authorized Distributor/Dealer service representative of the need for warranty service.

### **This warranty is subject to the following limitations:**

The purchaser must transport the product to and from the place of warranty repair. Any expense for travel or mileage is the responsibility of the purchaser.

---

Warranty service must be performed by Compact Power or its authorized Dealer's service representative

**The following items are not covered by this Track Limited Warranty:**

Parts that are not genuine original manufacturer service parts are not covered by this warranty.

Products which are damaged and sold as salvage units or in an "as is" condition are not covered by this warranty.

Any defect which is the result of misuse, alteration, improper assembly, improper adjustment, neglect, accident, or damage caused by natural calamity beyond human control such as fire, flood, etc. is not covered by this warranty.

**EXAMPLE OF THE 'PRORATED' COMPUTATIONS OF THIS TRACK LIMITED WARRANTY:**

First, divide the number of hours on the original tracks, the hours on the unit, by 400 to determine the "wear percentage factor." Next, subtract the result from 1 to determine the "prorated discount" to be applied to the cost of the track.

If a unit has 150 hours and requires a new track; divide 150 by 400 which equals .38, the "wear percentage factor." Subtract that number from 1 which equals .62, or 62%, the "prorated discount." In this case, the dealer will receive a warranty credit in the amount of his cost for the track less 62%. If the hours are less than 200 on the original track, a labor allowance of ½ hour will also be credited. No replacement labor will be paid if hours are over 200.

**LIMITATION OF REMEDY AND DAMAGES**

Compact Powers liability under this warranty, and under any implied warranty that may exist, is limited to repair of any defect in workmanship, and repair or replacement of any defective part. Compact Power shall not be liable for incidental, special, or consequential damages (including lost profits). Some states do not allow the exclusion of incidental or consequential damages, so the above limitation or exclusion may not apply to you.

**DISCLAIMER OF FURTHER WARRANTY**

**Compact Power makes no warranty, express or implied, other than what is expressly made in this warranty. If the law of your state provides that an implied warranty of merchantability, or an implied warranty of fitness for particular purpose, or any other implied warranty, applies to Compact Power, then any such implied warranty is limited to the duration of this warranty. Some states do not allow limitations on how long an implied warranty lasts, so the above limitation may not apply to you. This warranty gives you specific legal rights, and you may also have other rights which vary from state to state.**



---

# Boxer Warranty Registration

Dear Customer,

Mertz Manufacturing, LLC wishes to thank you for your purchase. We are committed to providing our customers with the finest products and product support available in any market today. To do this, we need to update our database with some specific information. Currently, the warranty start date is listed as the date the Boxer Trencher left Mertz Manufacturing, LLC. This may be several months before you ever received the product. Mertz

Manufacturing, LLC will restart the warranty date if you will complete the information below and return this form to us. We will continue to use the date the Boxer Trencher left the factory as the warranty start date of record until we are told differently through receipt of this form. Not returning the form could result in your being denied some of your warranty entitlements. To have Mertz Manufacturing, LLC reset the warranty start date, please complete the form below and mail or fax it back to: Mertz Manufacturing, LLC, P.O. Box 150, Ponca City, OK 74602, Fax: 580-767-8411.

***Please take the time to complete and return this warranty form.***

Fold

---

Name: \_\_\_\_\_

Address: \_\_\_\_\_

City: \_\_\_\_\_ State: \_\_\_\_\_ Zip: \_\_\_\_\_

Telephone No. \_\_\_\_\_

Location Purchased: \_\_\_\_\_

Date Purchased: \_\_\_\_\_ Salesman: \_\_\_\_\_

\_\_\_\_ I have received a copy of the Owners Manual for my engine.

\_\_\_\_ I need a copy of the Owners Manual for my engine.

Signed: \_\_\_\_\_

Model No. \_\_\_\_\_ Serial No. \_\_\_\_\_

---

Affix  
Stamp  
Here

Mertz Manufacturing, LLC  
P.O. Box 150  
Ponca City, OK 74602

---

# Safety Introduction

---

## Be Prepared - Get to Know All Operating and Safety Instructions

This is the Safety Alert Symbol.



Wherever it appears, either in this manual or on safety signs on the machine, you should be alert to the potential for personal injury or accidents. Always observe safety precautions and follow recommended procedures.

## Learn the Signal Words Used with the Safety Alert Symbol

The words “DANGER”, “WARNING”, and “CAUTION” are used throughout this manual and on labels on the machine indicate hazards or unsafe practices. All three statements indicate that safety is involved. Observe the precautions indicated whenever you see the Safety Alert symbol no matter which signal word appears next to the Safety Alert symbol.

 **DANGER**

**INDICATES A HAZARDOUS SITUATION THAT, IF NOT AVOIDED, IS VERY LIKELY TO CAUSE DEATH OR EXTREMELY SERIOUS INJURY. IT MAY ALSO BE USED TO ALERT AGAINST EQUIPMENT THAT MAY EXPLODE OR DETONATE IF HANDLED OR TREATED CARELESSLY.**

 **WARNING**

**Indicates a hazardous situation that, if not avoided, could result in serious injury or death. It may also be used to alert against a highly unsafe practice.**

 **CAUTION**

**Indicates a hazardous situation that, if not avoided, could result in minor or moderate injury. It may also be used to alert against a generally unsafe practice.**

**NOTICE**

This type of statement is used to draw attention to a procedure that needs to be followed to prevent machine damage.



# Table of Contents

---

<b>Boxer Product Warranty</b> .....	<b>i</b>
<b>Track Limited Warranty Policy Statement</b> .....	<b>iii</b>
<b>Safety Introduction</b> .....	<b>vii</b>
Be Prepared - Get to Know All Operating and Safety Instructions .....	vii
Learn the Signal Words Used with the Safety Alert Symbol.....	vii
<b>Section 1 – Safety Precautions</b> .....	<b>1-1</b>
GENERAL SAFETY .....	1-1
OPERATING SAFETY .....	1-2
SERVICE & MAINTENANCE SAFETY .....	1-4
ELECTRICAL SYSTEM HAZARDS .....	1-4
Battery Hazards .....	1-5
Jump Starting/Battery Charging Hazards .....	1-5
Hydraulic System Hazards .....	1-6
Fueling Hazards .....	1-7
<b>Section 2 – Operating Controls</b> .....	<b>2-1</b>
Component Locations .....	2-1
Right Front View .....	2-1
Left Rear View .....	2-2
Operating Controls .....	2-3
Safety Decals .....	2-4
Operating Controls Description .....	2-5
<b>Section 3 – Pre-Start Inspection and Operation</b> .....	<b>3-1</b>
Pre-Start Inspection.....	3-1
Daily Service Checks .....	3-1
Operating Instructions .....	3-7
Machine Start-up .....	3-7
Machine Shut-down.....	3-8
Transportation .....	3-8
Lifting Procedures.....	3-9
Machine Travel Controls .....	3-10
Operating Instructions .....	3-15
<b>Section 4 – Routine Service and Maintenance</b> .....	<b>4-1</b>
Daily Maintenance Procedures .....	4-2
New Machine Brake-in Maintenance Procedures .....	4-8
Weekly Maintenance Procedures.....	4-11
Monthly Maintenance Procedures .....	4-12
Annual Maintenance Procedures .....	4-16
General Maintenance .....	4-18
Draining Fuel Tank .....	4-18
Adjusting Digging Chain Tension .....	4-20
Trencher Boom Replacement.....	4-22
Replacing the Digging Teeth .....	4-24
Replacing the Drive Sprocket .....	4-25
Chain Configuration.....	4-27
Chain Master Link.....	4-28

---

Configuring the Chain .....	4-29
Parts List .....	4-30
Boxer 118 Hydraulic Interconnect Diagram .....	4-32
<b>Section 5 – Troubleshooting .....</b>	<b>5-1</b>
<b>Section 6 – General Specifications .....</b>	<b>6-1</b>
Noise Data .....	6-2

# Section 1 – Safety Precautions

---

Since Mertz Manufacturing has no direct control over machine application or operation, following the proper safety practices is the responsibility of the owner and/or operator. Remember that this unit is only as safe as those who operate it. Safety tips shown throughout this Operator's Manual must be followed at all times.

## GENERAL SAFETY

- Never operate the Boxer without first completely reading and understanding this Owner's Manual.
- Only authorized, qualified, and trained personnel are allowed to operate this machine.
- Never operate the machine under the influence of alcohol, awareness altering drugs, or medications that would affect your ability to operate safely.
- **KEEP CHILDREN CLEAR FROM THE WORK SITE AREA AT ALL TIMES!**
- **NEVER ALLOW A CHILD TO OPERATE OR RIDE ON THE MACHINE**
- Serious injury or death involving children can occur. Stay ALERT and be aware of your surroundings at all times. Stop operations if children wander onto the job site. Resume work only when the operating area is clear.
- Keep all non-operating personnel away from the machine during operation.
- Passengers must never be allowed to ride on the machine.
- Wearing protective clothing and gear, such as hard hats, safety glasses, safety shoes, hearing protection, breathing protection, and long pants and shirts is highly recommended. Do not operate in clothing or shoes which will expose skin or feet to possible flying debris.
- Clothing should be relatively close fitting. Loose clothing, rings, and other jewelry should be avoided because of the danger of catching them on machine parts or controls or on any rotating parts, either on the machine or any attachment.
- Keep hands/fingers clear from all rotating parts.
- Never touch engine parts or machine components while they are hot.
- Always perform the “Standard Shut Down Procedure” shown in this manual, if the unit will be left unattended for any length of time.
- Use only original BOXER or approved replacement parts. Imitation parts may lead to unit damage and/or injury to personnel. The machines' warranty may be voided if unauthorized parts are used.

## OPERATING SAFETY

- Plan ahead and learn as much as possible about your job-site area before beginning any work.
- Know the exact location of overhead power lines or obstructions.
- Have all buried lines such as; gas, electric, water, telephone and cable TV, marked by the proper authorities.
- Prior to use, perform the "Pre-Start Inspection" and Daily Maintenance to make sure that the unit is in safe operating condition.
- Never operate a malfunctioning unit!
- Keep hands, gloves, shoes, control knobs, and operator platform clean. Slippery controls can cause you to lose control, which may result in an accident.
- Always keep a firm grip on the hand rails located at the operator's platform during travel and operation to prevent falling off the unit.
- When working on an unfamiliar construction site, review, understand and follow job site safety rules.
- Keep the work site clear of all non-operating personnel. Should a person enter the work area, stop machine operation until the work area is clear.
- Prior to unloading the unit and starting to work, inspect the path you will travel and work site area for potential hazards. Some of the hazardous conditions you may encounter are:
  - Holes
  - Deep ditches or excavations
  - Drop-offs
  - Soft un-compacted soil
  - Culverts
  - Deep mud / Standing Water
  - Large rocks
  - Slippery surfaces
  - Steep slopes
  - Tall grass, trees, or shrubs

If any of these conditions exist, correct the hazard or obstruction. If any of these conditions can not be corrected, avoid operating or traveling near them.

- Be extremely cautious traveling through or near trees, brush, shrubs or any obstacles which might obscure your vision. These might hide potential hazards, such as the edge of a steep slope, deep holes, large rocks, etc.
- Never operate near a ditch or embankment where loose or soft ground conditions could cause the surface to give way under the machine causing it to become unstable.
- Never exceed the rated capacity of the machine.
- Operate all controls slowly and smoothly and never abruptly stop any function. This can cause the machine to become unstable.
- Always look in the direction of travel.
- Come to a complete stop prior to reversing travel directions.
- Reduce speed and proceed with caution when traveling in reverse or turning.
- Never travel with the trencher boom raised. Lower the boom as soon as possible and travel with the boom at the lowest safe height.
- Approach corners slowly, turning too fast or sharp may cause the machine to tip over.
- Stay alert when operating near traffic or roadways.



- If the unit should begin to tip or become unstable, DO NOT try to stabilize the unit with your legs or arms.
- If the unit is involved in an accident or inadvertently damaged during operation, stop and perform a thorough inspection. Make sure the unit is in safe operating condition prior to resuming work.
- Be alert to any unusual reaction to any of the controls. If anything unusual is noticed, shut the machine down and thoroughly inspect it to determine the cause of the problem. Do not operate the machine until all required repairs have been made.
- If the unit must be left unattended, shut the machine down and make sure that it can not be started by an unauthorized individual.
- Operating on steep slopes can be dangerous and there is a greater risk of the machine tipping over or becoming unstable. The list of rules below must be understood and followed for maximum safety:
  - Avoid excessively steep slopes or unstable surfaces. If travel on a slope is necessary, keep the load low and proceed with extreme caution.
  - DO NOT travel ACROSS excessively steep slopes under any circumstances.
  - Travel straight up and down slopes with the heavy end of the machine pointing up the incline. When the machine has no load, the operator's platform end of the machine is considered the heavy end.
  - Turning on slopes is not a recommended practice, however if you must turn on slopes; reduce travel speed to as slow as possible, and exercise extreme caution. Avoid sharp turns or sudden movements.
  - Wet or slick ground conditions should be avoided as reduced traction could cause the machine to slide down the slope.
  - Never park the unit on a slope.

## SERVICE & MAINTENANCE SAFETY

Maintenance work can be hazardous if not done in a careful manner. All personnel should realize the hazards and strictly follow safe maintenance practices. Failure to comply with these safety precautions may result in serious personal injury and/or death.

- Use only BOXER supplied or approved replacement parts. Imitation parts may lead to unit damage and/or injury to personnel. Warranty may be voided if unauthorized parts and are used.
  - Wear the proper protective clothing and personal safety equipment necessary to perform the maintenance or service required.
  - Keep the machine free of grass, leaves, or other debris build-up.
  - Clean up oil or fuel spillage.
- 

### **WARNING**

#### **Fuel or oil leaks or spills can create a fire or explosion hazard.**

---

- Prior to performing maintenance or service, park the unit in a level area away from obstructions and/or work site hazards.
- Be sure the area has adequate light and is well ventilated. NEVER operate the machine inside a closed area.
- Clean-up any oil, grease, mud, water, or snow which might cause the floor surface to become slippery.
- If the machine requires maintenance, take the machine out of service and attach a "Do Not Operate" tag at the control panel and remove the ignition key.
- If maintenance or repairs require the boom to be raised, securely support the boom.
- Know where all pinch points and rotating parts on the unit are. These areas must be avoided to prevent serious injury.
- Remove only those guards or covers on the component being serviced and replace them immediately upon completion of the work.
- Never attempt to adjust or service engine or machine components while they are hot.

## ELECTRICAL SYSTEM HAZARDS

- Prior to working on the electrical system:
  - Disconnect battery cables, removing the battery ground cable first.
  - When re-connecting the battery, connect the battery ground cable last.
  - Never allow battery cables to contact hydraulic lines or rub against sharp edges.

## Battery Hazards

Before working with batteries, the following are important points about battery safety that you should be aware of:

- Batteries are always surrounded by extremely explosive gases. This is especially true when the battery is being charged. To avoid explosion:
  - Do not smoke near batteries.
  - Keep arcs, sparks and open flames away from batteries.
  - Perform battery service work only in a well ventilated area.
- Make sure to dispose of batteries according to local regulations.
- Electrolyte Hazards:

## NOTICE

The batteries on the machine may be either be “wet cell” or gel cell. It is still important to know and follow these warnings and cautions.

- Battery electrolyte in standard “wet cell” batteries contains sulfuric acid which is poisonous and can cause severe chemical burns. To avoid personal injury:
  - Wear a face shield to prevent sulfuric acid contact with your eyes
  - Wear chemical resistant gloves and clothing to keep acid off your skin and clothing.
  - Since wet cell batteries give off explosive gases, use a flashlight to check the electrolyte level, not an open flame such as a match.
  - Never check the battery by placing a metal object across the battery posts. The resulting spark could ignite anything flammable, causing fire or an explosion.
  - If electrolyte is splashed into your eyes, flush them immediately with clean water and seek medical attention.
  - If electrolyte is swallowed, seek medical attention immediately.
  - If electrolyte is splashed onto exposed skin or clothing, flush and clean the area immediately with clean water and seek medical attention if necessary.

## Jump Starting/Battery Charging Hazards

Follow the instructions for jump starting or battery charging in the engine owner's manual. You must be at the operator's platform when attempting to start the unit with booster batteries and jumper cables so that you are at the controls when the engine starts.

Here are some general safety rules you must follow for jump starting the machine:

- Make sure to connect the positive jumper cable to the positive (RED) terminal on the battery.
- Connect the negative cable to the engine, machine chassis or the furthest ground point away from the battery. Never make the final connection at the starter or dead battery. Sparks may ignite the explosive gases surrounding the battery.
- When disconnecting cables after jump starting, remove the negative cable first and then the positive cable. **IMPORTANT: DO NOT** let the cable clamps touch when disconnecting them.
- Severe damage can occur to the booster battery or machine.
- Never charge a battery or attempt to jump start a frozen battery. The sudden surge in electrical power could cause the battery to explode.

### Hydraulic System Hazards

The hydraulic system is under pressure whenever the engine is running and may hold pressure even after the engine is shut off. Cycle all hydraulic controls after the trench boom is resting on the ground. Some components will retain residual or trapped pressure. Use extreme caution when removing any hydraulic component.

During inspection of the hydraulic system:

- Cycle all hydraulic controls to release residual pressure.
  - Wait for the hydraulic fluid to cool down before disconnecting any hydraulic lines. Hot hydraulic fluid can cause severe burns.
- 



**Hydraulic oil under pressure can penetrate body tissue causing serious injury and possible death. When troubleshooting a hydraulic system for leaks, always use cardboard or wood as a detector. DO NOT USE YOUR BARE HANDS. If you are injected with hydraulic oil or any other fluids, immediately seek treatment by a doctor trained in the treatment of penetrating fluid injuries.**

---

- Hydraulic fluid can cause permanent eye injury. Wear safety glasses or a full face shield to provide appropriate eye protection.
- When venting or filling the hydraulic system, loosen the filler cap slowly to allow any pressure in the hydraulic tank to be released and remove the cap gradually.

---

## Fueling Hazards

Most fuels are highly flammable. Observe the following precautionary practices to reduce the possibility of a serious accident:

- Always refuel the unit in an open, well ventilated area away from sparks or open flames.
- 



### Gasoline Engines:

- Shut the engine off before attempting to fuel the machine. Never refuel a unit while it is running.
  - Allow engine to cool before re-fueling
  - Always use a funnel or pour spout when filling the tanks.
  - Under certain circumstances a static charge can develop and ignite the fuel. Make sure that you are standing on the ground when filling the fuel tanks.
  - If you are filling the fuel tanks from a service vehicle, make sure to connect the service vehicles ground cable to the machine before beginning the fueling process.
  - Keep the fuel nozzle in constant contact with the rim of the machines fuel tank.
  - When filling a portable gas container, always place it on the ground. Never fill a portable fuel container while it is inside a vehicle, truck, pick-up bed, or any surface.
  - To avoid static sparks when using a portable fuel container, only fill the container when it is positioned on the ground and keep the fuel container nozzle in contact with the tank opening during filling.
  - Make sure to move the unit from the transport truck or trailer and only refuel the unit on the ground, using an approved container.
  - Keep sparks and flames away from fuel.
  - Do not smoke while refueling or when handling the fuel container.
  - Never cut or weld on or near fuel lines, tanks or containers.
  - Never overfill the tank.
  - Clean up spilled fuel immediately.
  - Store fuel in an approved container and keep out of the reach of children.
-



# Section 2 – Operating Controls

## Component Locations

### Right Front View

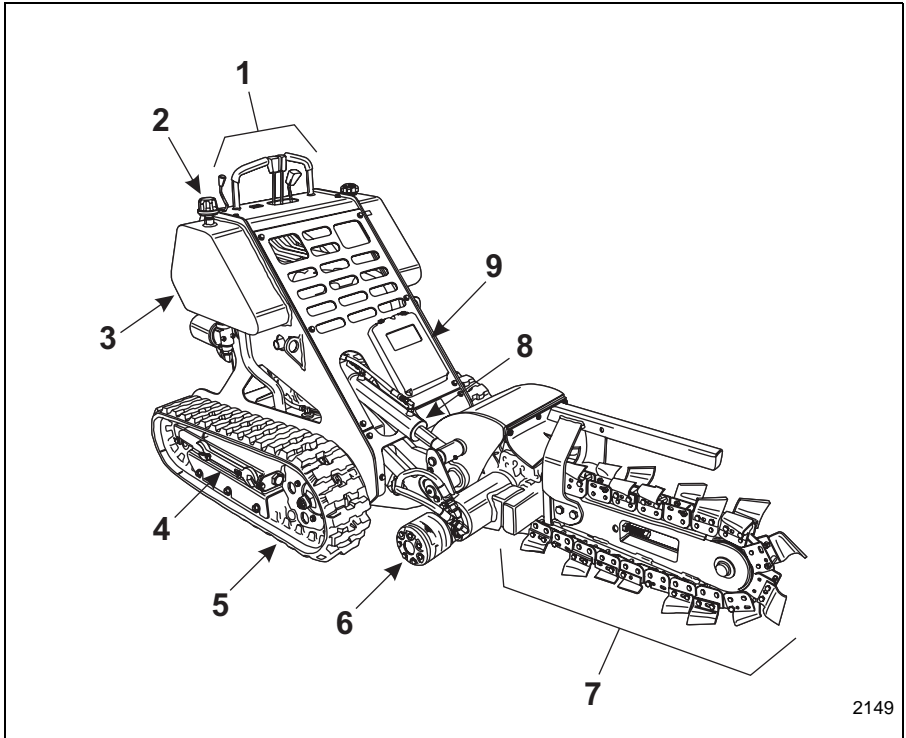

Item No.	Description
1	Operating Controls
2	Hydraulic Fluid Level Dipstick and Tank Fill Port
3	Hydraulic Tank
4	Track Adjusting Wrench
5	Right Hand Track Drive
6	Trencher Drive Motor
7	Trencher Assembly
8	Boom Raise Cylinder
9	Manual Holder

**Left Rear View**

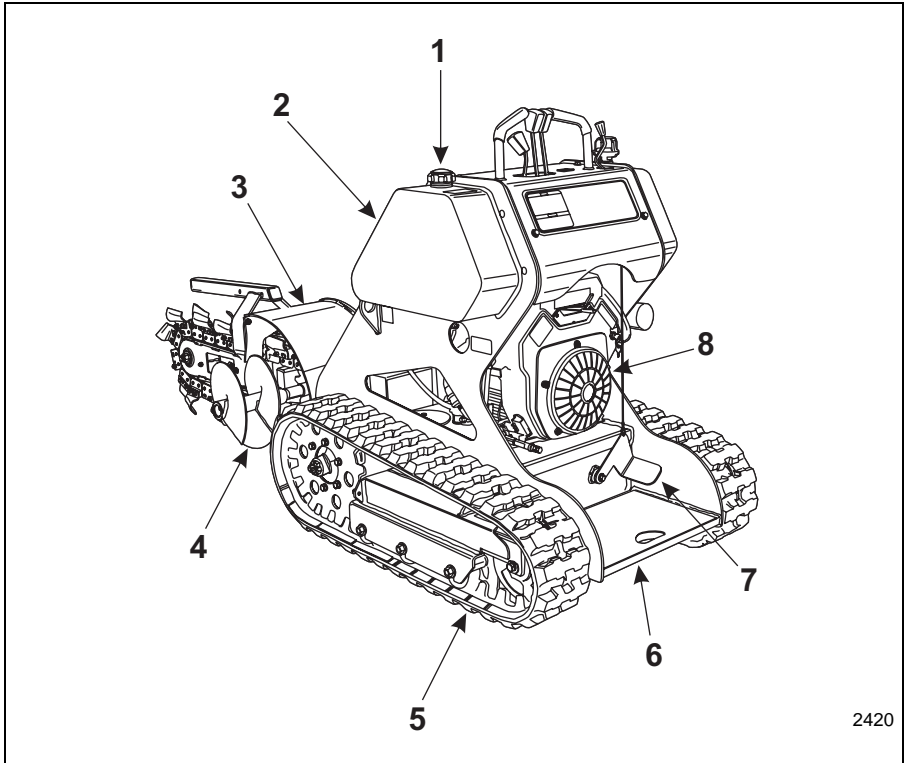

2420

Item No.	Description
1	Fuel Gauge and Fuel Filler Cap
2	Gas Tank
3	Rock Guard
4	Spoils Auger
5	Left Track Assembly
6	Operator's Platform
7	Trencher Activation Lock Lever
8	Engine



## Operating Controls

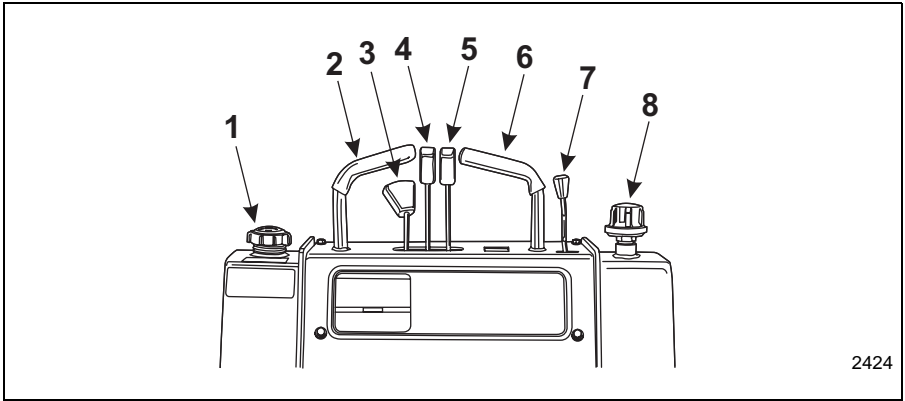

2424

Item No.	Description
1	Fuel Gauge and Fuel Filler Cap
2	Left Hand Grip
3	Trencher Boom Raise and Lower Control Lever
4	Left Travel Control Lever
5	Right Travel Control Lever
6	Right Hand Grip
7	Trencher Activation Control
8	Hydraulic Filler Cap and Dipstick

**Safety Decals**

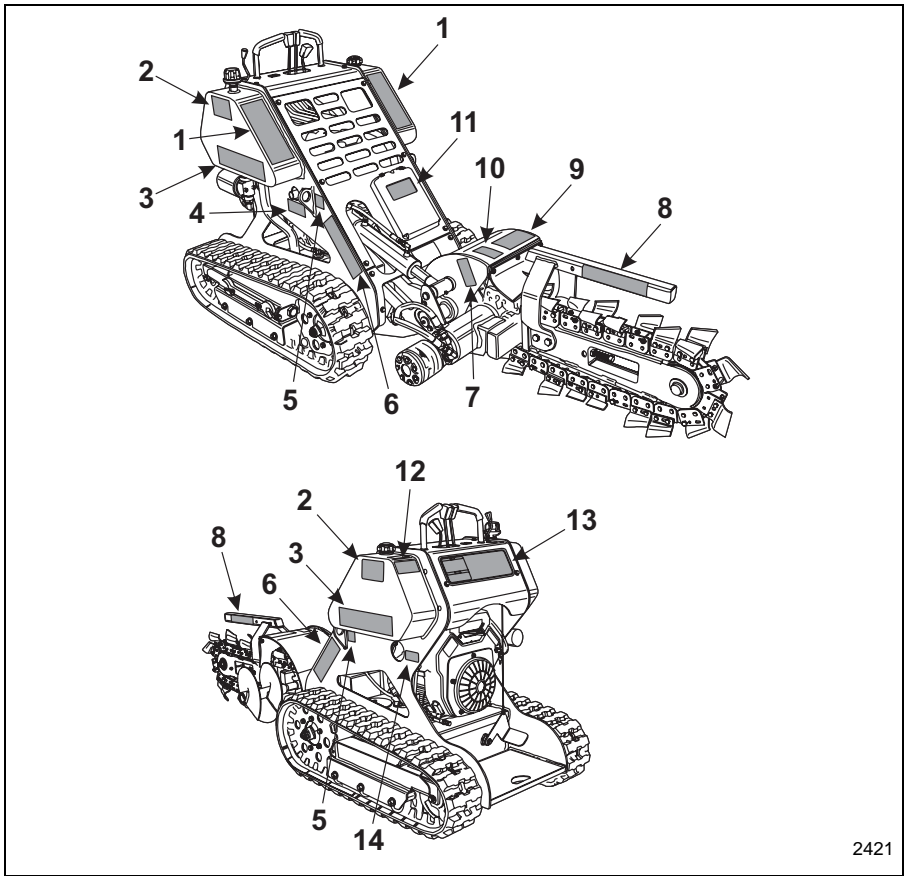

2421

Item No.	Description
1	118 Model Number
2	Keep Distance Warning
3	CPI Logo
4	Burn Hazard Warning
5	Tie Down and Lifting Hazard Decals
6	Boxer Logo
7	Crush Hazard Decal
8	Stand Clear Warning Decal
9	Entanglement Hazard Decal
10	Shock Hazard Decal
11	Read Manual Decal
12	Fuel Explosion Hazard Warning Decal
13	Operating Instruction Decal
14	Fuel Shut Off Warning

## Operating Controls Description

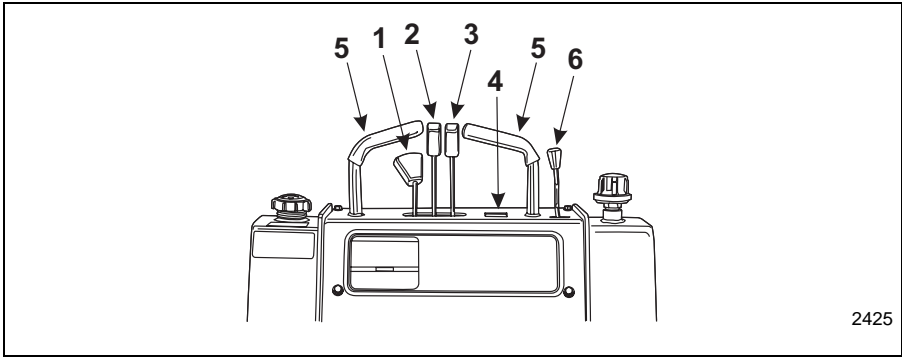

2425

1. **Boom Raise and Lower** – This lever controls the raising and lowering of the trencher boom assembly.
2. **Left Travel Motor Control** – Pushing the lever forward rotates the left side track for forward travel. Pulling the lever backwards rotates the left side track for reverse travel.
3. **Right Travel Motor Control** – Pushing the lever forward rotates the right side track for forward travel. Pulling the lever backwards rotates the right side track for reverse travel.
4. **Engine Hour Meter Gauge**
5. **Hand Grip**
6. **Trencher Operation** – There are three positions for the Trencher Control Lever. To activate the control lever, the operator may step on the operator presence control lever and hold the lever in the downwards position. This allows the trencher control lever to be moved.
  - a. The center and forward position of the trencher control lever is the Neutral position. With the lever in this position, the trencher chain will not move.
  - b. The main operating position is when the trencher control lever is moved to the right into the Forward position. The control will remain in this position until it is moved back into the Neutral position or you step off of the operator presence control.
  - c. If it is required, the trencher chain can be reversed by moving the control lever to the left hand side of the slot. The control lever will not remain in this position, and if you let it go, the lever will return to the neutral position.

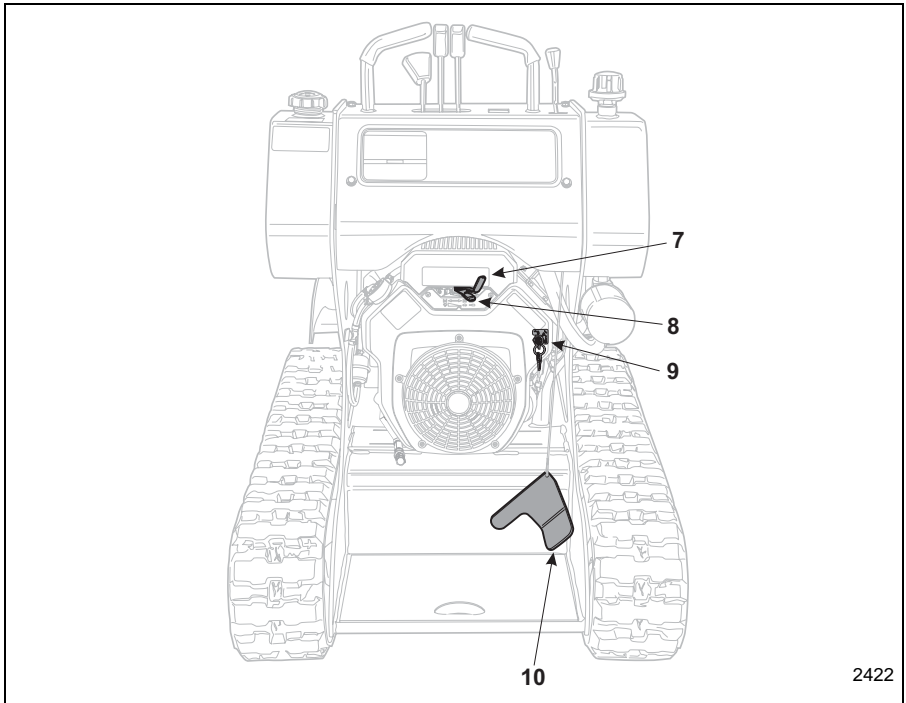

2422

7. **Engine Choke** – Moving the lever to the left sets the choke for easier cold engine starting. Moving the lever to the right opens the choke and allows the warmed up engine to run properly.
8. **Engine Throttle** – Moving the control lever to the left increases the engine speed and moving the lever to the right slows the engine to idle speed.
9. **Keyswitch** – Starts and stops the engine.
10. **Trencher Activation "Operator Presence" Pedal** – This pedal must be stepped on and held in the downwards position before the trencher control lever is moved from the center Neutral Lock position. When the operator presence control has been depressed, the trencher activation control lever will be able to be moved into either the Forward or Reverse position, activating the trencher chain. If the operator releases this control pedal, the trencher hydraulic control lever will return to the Neutral position, stopping the trenching operation.

# Section 3 – Pre-Start Inspection and Operation



**IMPROPER USE OF THE COMPACT TRENCHER COULD CAUSE SERIOUS INJURY OR DEATH. BEFORE OPERATING THE MACHINE, OR PERFORMING MAINTENANCE, THE OPERATOR MUST READ AND UNDERSTAND THE ENTIRE OPERATOR'S MANUAL, REVIEW MACHINE CONTROLS, LOCATE AND REVIEW ALL WARNINGS AND SAFETY PLACARDS AND RELEVANT OPERATOR SAFETY MATERIALS INCLUDING WRITTEN, VISUAL, VIDEO OR VERBAL INSTRUCTIONS.**

## Pre-Start Inspection

It is very important to do a visual inspection of the machine before beginning operation. This inspection should include:

- Check all decals and warning signs for damage.
- Check engine oil.
- Check and refill the fuel tank.
- Check hydraulic lines and hoses for signs of damage or leaks.
- Inspect the machine for any signs of damage or loose fasteners.
- Check fluid levels and any signs of leaking fluids.
- Do all Daily Service Checks.
- Check machine controls to make sure that they automatically return to the neutral position.

The following information presents details on these inspection points and service checks.

## Daily Service Checks

**Table 1: Service Cycle Table**

Activity	Daily (10 Hours)
Fuel	✓ and R
Engine Oil	✓ and A
Air Filter	✓
Hydraulics	
- Hydraulic Fluid	✓
- Hydraulic Hoses	✓
Grease	✓***
Tracks	✓
Check Chain Tension	✓
Visual Check for Loose/Missing Fasteners	✓
Battery	
Check and Adjust Track Tension	✓

Service Cycle - R = Replace ✓ = Check A = Add

\*\*\*Under very wet, muddy, dusty or dirty working conditions more frequent lubrication may be required.

Before starting the engine, do the following pre-start service checks:

1. Check condition of all warning and instructional decals. Replace any damaged decals with genuine BOXER replacement decals.
2. Check engine oil -

## NOTICE

The engine oil dip-stick and engine oil filler port can be reached through the top openings of the front protective cover.

- Make sure that the engine is OFF.
- Pull out the dipstick (Item 1, **Figure 3-1**) and look for both the full and add oil lines (Item 2, **Figure 3-1**) indicated by the letters "F" and "A". The correct oil level is between those two lines.

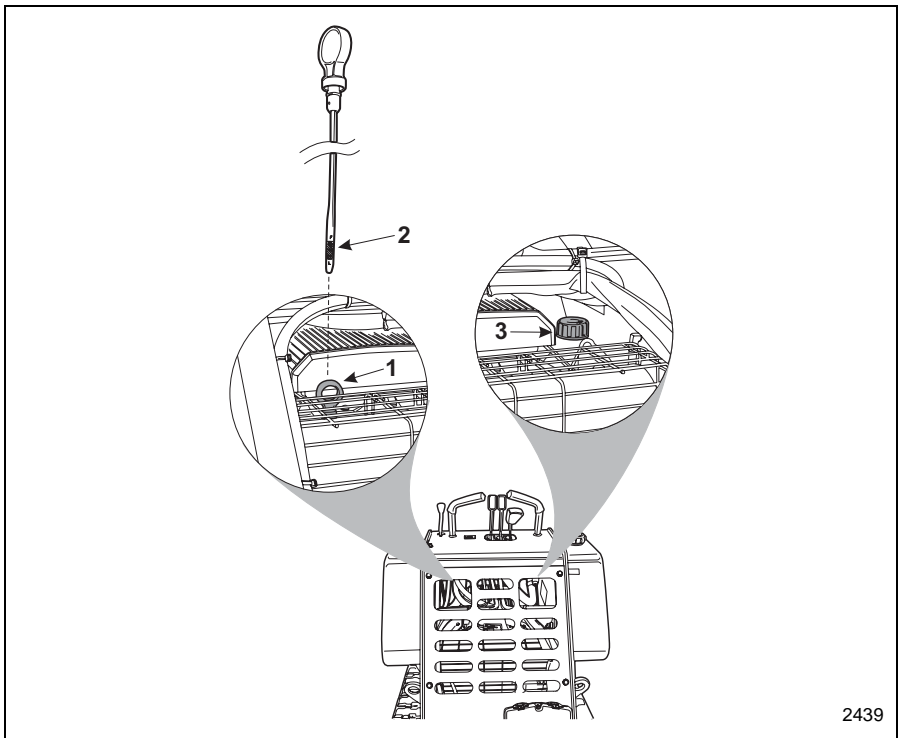

Figure 3-1 Engine Oil Level Check

- If the engine oil level is below the add line, indicated by the letter “A” on the dipstick, carefully add the proper amount of oil through the engine oil filler (Item 3, **Figure 3-2**). It is important to add the correct type of engine oil as stated in the engine manual.

## NOTICE

- Make sure to reinstall and secure the oil filler cap.
  - Extremely dusty or dirty working conditions may require more frequent checking, filling and/or changing of engine oil.
- After filling the oil, wait a few minutes and check the oil level again.

## NOTICE

Make sure to securely reinstall the dipstick into the dipstick tube before starting the engine.

## ⚠ CAUTION

- **Allow engine to cool before filling fuel tank.**
  - **Do not overfill the fuel tank. Fuel could spill onto hot engine parts and ignite or explode.**
3. The Boxer has one saddle fuel tank (Item 1, **Figure 3-2**). The tank has a fuel gauge (Item 3, **Figure 3-2**) located in the filler cap (Item 2, **Figure 3-2**). Remove cap and visually inspect fuel level to make sure that the indicator is showing the proper fuel level. Make sure that the tank has been filled on a daily basis. Carefully add fuel.

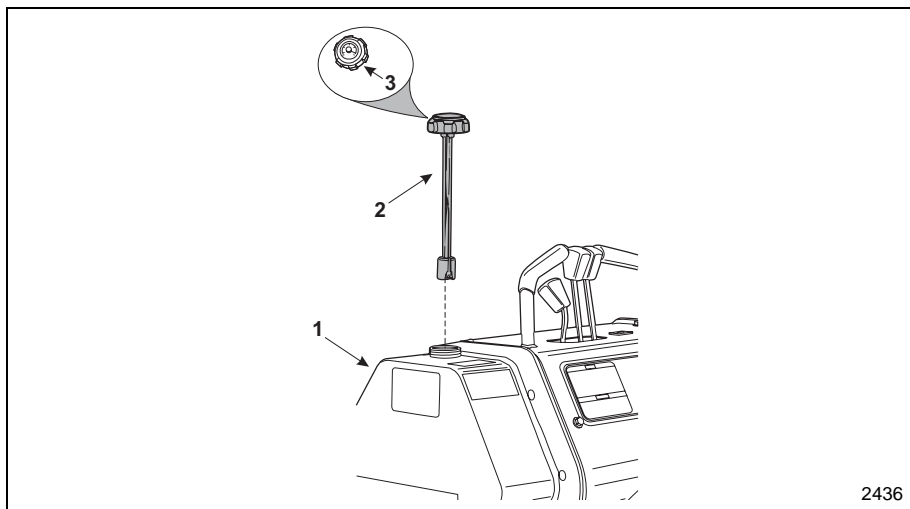

2436

Figure 3-2 Fuel Level Check

4. Check all hydraulic hoses, lines and fittings.

## ⚠ WARNING

Hydraulic oil under pressure can penetrate body tissue causing serious injury and possible death. When troubleshooting a hydraulic system for leaks, always use cardboard or wood as a detector. **DO NOT USE YOUR BARE HANDS.** If you are injected with hydraulic oil or any other fluids, immediately seek treatment by a doctor trained in the treatment of penetrating fluid injuries.

- Visually inspect all of the hydraulic hoses, lines and fittings for signs of damage, wear or leaking.
- If any signs of damage are visible, do not operate the machine until repairs have been made.
- Some examples of common hydraulic hose damage are shown in [Figure 3-3](#).

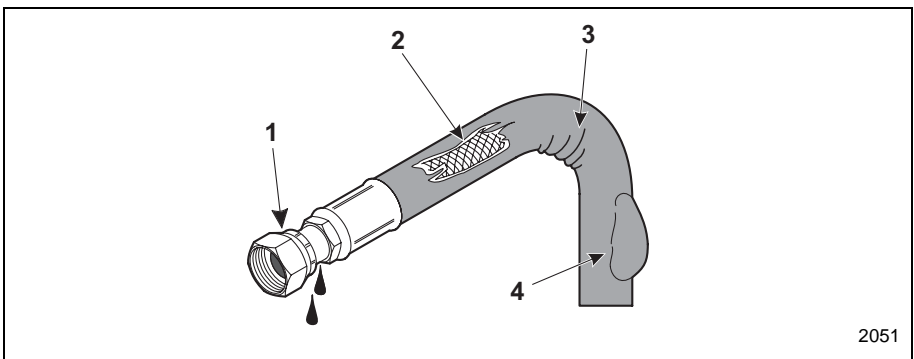

Figure 3-3 Hydraulic Hose Damage

1. End fittings damaged or leaking
  2. Outer covering chafed or cut, and wire reinforcing is exposed
  3. Hose shows signs of kinking or crushing
  4. Outer covering ballooning
5. Check for loose or missing fasteners
    - Inspect for any loose or missing bolts.
    - Tighten or replace any missing bolts immediately.
  6. While you are performing the daily maintenance, inspect the machine for any signs of damage, such as missing or damaged components, cracked welds, etc.
  7. Check the track assemblies to make sure that:
    - The tracks are in good condition and are not showing any signs of wear.
    - Track tension is properly set.
    - Track drive motors are not leaking oil or hydraulic fluid.



8. Grease pivot shafts with proper type of grease. There are 5 grease points on this machine, see [Figure 3-4](#).

## NOTICE

The grease zerk below the chain tension bolt should only be greased monthly.

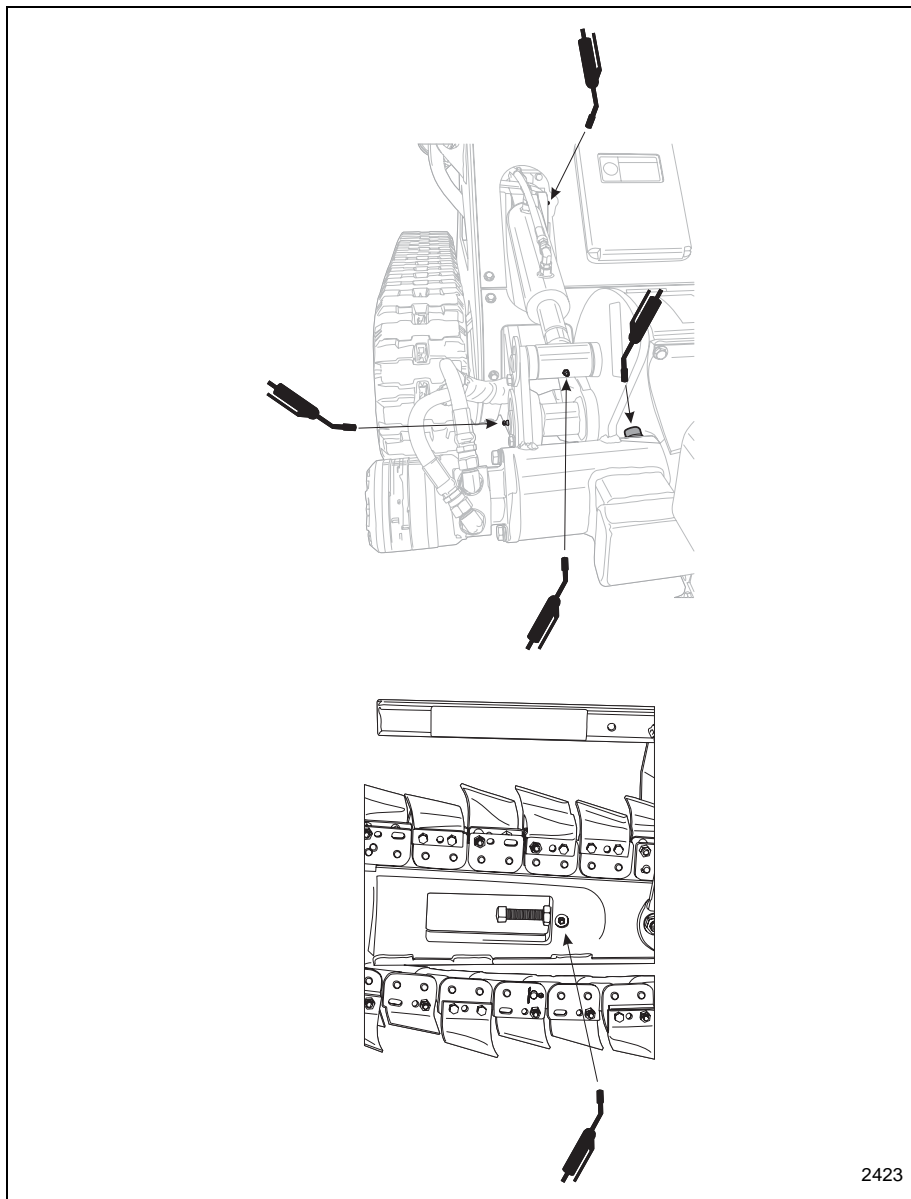

2423

Figure 3-4 Grease Zerk Locations

## CAUTION

### Before starting the engine:

- Move all hydraulic control levers forward and release the lever. Make sure that each lever automatically returns to the Neutral position.
  - Move all hydraulic control levers rearward and release the lever. Make sure that each lever automatically returns to the Neutral position.
  - Step on the operator presence control and shift the Trencher Control Lever to the right into the trenching position. The control lever should remain in that position as long as the dead man control is held down. Releasing the operator presence returns the Trencher Control Lever to the neutral position.
  - If any of the levers, other than the Trencher Control Lever, does not automatically return to the Neutral position, DO NOT use the machine until repairs have been completed.
- 

## NOTICE

Extremely dusty or dirty working conditions may require more frequent service/replacement.

---

## Operating Instructions

### Machine Start-up

To start the machine, the operator must:

1. Stand on the operator's platform (Item 1, [Figure 3-5](#)).
2. Move the throttle lever (Item 2, [Figure 3-5](#)) to about half way between fast and idle engine speeds.
3. Move the engine choke lever (Item 3, [Figure 3-5](#)) to the CHOKE position.
4. Rotate and hold the starter switch (Item 4, [Figure 3-5](#)) in the START position until the engine starts.

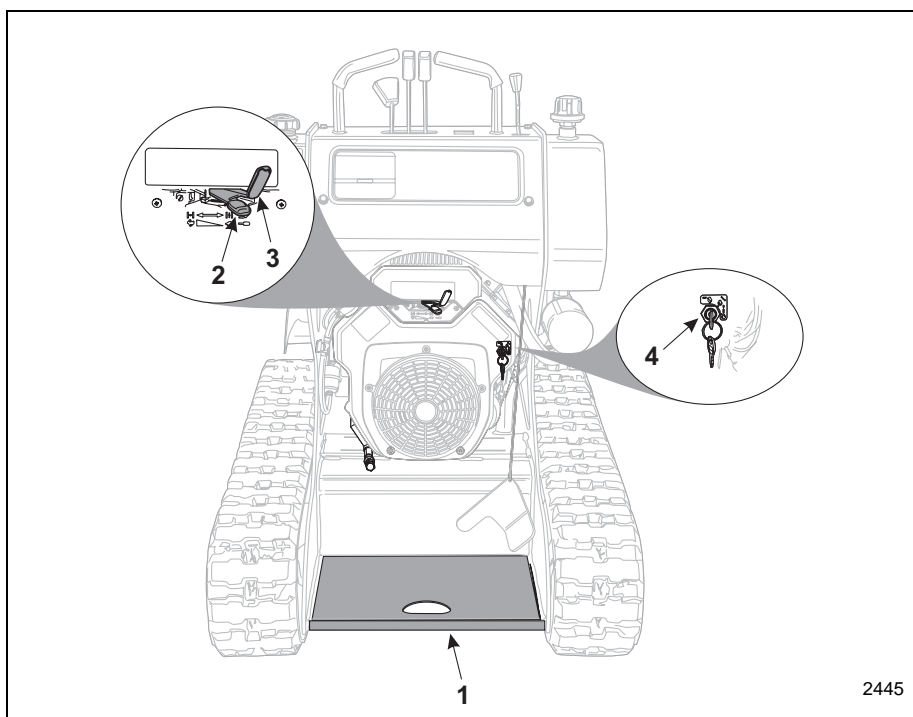

Figure 3-5 Operator's Platform, Engine Throttle, Choke and Key Switch

5. As soon as the engine starts, release the starter key. The key will automatically return to the RUN position.
6. Leave the throttle setting at about the halfway position and allow the engine to idle. This will begin warming the hydraulic oil.
7. If the engine begins to labor or sputter, move the choke control lever to the normal run position. It may be necessary to move the choke lever only part way to the normal position until the engine has warmed up.
8. In cold weather (32° F [0° C]) after about 5 minutes of engine idling, operate all of the main hydraulic controls to cycle warmed hydraulic oil through the hydraulic lines into the cylinders and hydraulic motors. Allow the engine to idle for another 5 minutes before beginning any machine operations.

## ⚠ WARNING

**In extremely cold weather fully warm machine to prevent a possible machine run-away condition.**

### Machine Shut-down

To safely shut the machine down, the operator must:

1. Park the machine on a solid, level area.
2. Lower the trencher boom to the ground.
3. Idle the engine for 5 - 10 minutes to allow the machine to cool down.
4. Shut off the engine.
5. Clean off any accumulated mud and/or dirt from the machines operating surfaces, i.e. operator's platform, both track assemblies, trencher chain assembly, etc.

### Transportation

1. Move the throttle control lever to the mid-range engine speed. Raise the boom so that it will clear the ramp of the transport trailer.

## NOTICE

It is recommended to back the machine onto the transport trailer and position the machine so that the heaviest weight (center of balance) is towards the front (hitch end) of the trailer. See [Figure 3-6](#).

## ⚠ CAUTION

**The Boxer is designed for maximum working balance. When traveling on an incline, always have the heaviest portion of the machine pointing uphill.**

2. Follow general load carrying safety. Always carry the heaviest load pointing uphill.

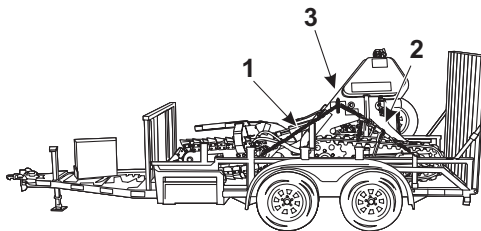

2434

Figure 3-6 Transport Position on Trailer

3. When the machine is positioned on the trailer properly, lower the boom to the trailer deck.
4. Shut the engine off and remove the key.
5. Secure the unit to the transport vehicle with DOT (Department of Transportation) approved chains, binders (Items 1 and 2, **Figure 3-6**), and DOT guidelines. Make sure to use the appropriate tie-down locations on the machine and trailer.

## NOTICE

- Never tow or pull the machine. Damage to the hydraulic motors could result.
- If the machine is totally in-operable, using lifting straps or cables and a machine that can safely lift 3,000 lbs. (1,361 kg), lift the machine and place on a trailer.

## ⚠ WARNING

**When transporting the machine, make sure to use DOT approved chains and binders (Items 1 and 2, **Figure 3-6**) to secure the machine to the “D” rings on the trailer.**

## NOTICE

It is recommended to secure the machine through the tie downs (Item 3, **Figure 3-7**) located on each side of the machine framework.

### Lifting Procedures

When it becomes necessary to lift the machine:

1. Start the engine and fully raise the trencher boom, then shut off the engine.
2. Use a lifting device that can safely lift 3,000 lbs (1,361 Kg).
3. Use appropriate lifting chains (Item 1, **Figure 3-7**) that can safely lift 3,000 lbs (1,361 Kg).
4. Route the chains through the lifting eyes (Item 2, **Figure 3-7**) located on the sides of the machine.
5. Route another lifting chain (Item 3, **Figure 3-7**) through the center hole in the boom assembly (Item 4, **Figure 3-7**).
6. Connect all three lifting chains with the central lifting chain (Item 1, **Figure 3-7**).

## ⚠ CAUTION

- **Lift the machine approximately 12" to make sure that the machine is balanced before completing the lift.**

7. Do a short test lift to make sure that the machine is lifted evenly. Adjust the lifting chains (Items 2 and 3, **Figure 3-7**) as needed to lift the machine evenly.

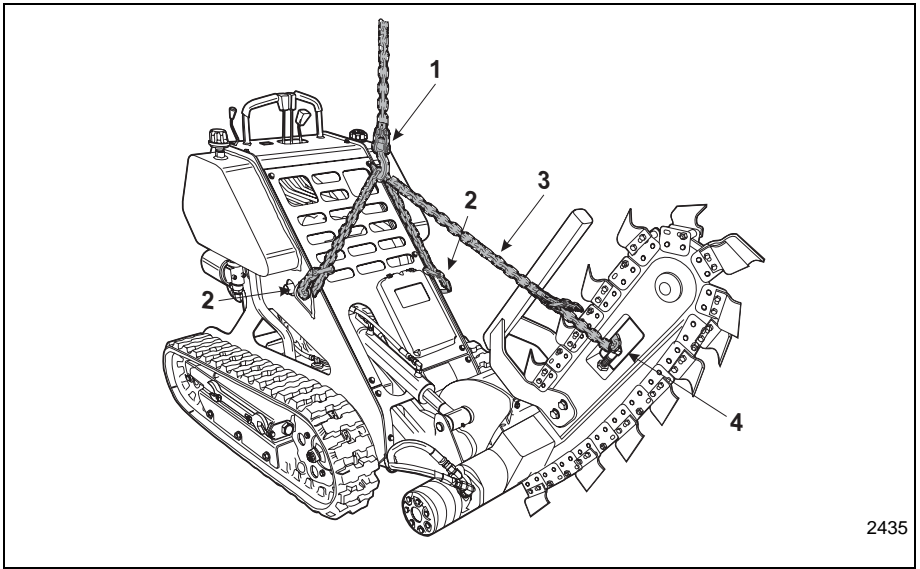

2435

Figure 3-7 Machine Lifting

## Machine Travel Controls

### **⚠ WARNING**

- Levers and controls should return to the neutral position when they are released.
- Make sure that all of the controls are in the neutral (middle) position before starting the engine.
- Operate the controls gradually and smoothly. Excessive speed and quick control movements without regard for working conditions could cause an unsafe situation.
- Make sure to maintain your grip on both of the hand grips any time the machine is in motion.

### **NOTICE**

Due to the spring tension system built into the track drive system as a safety mechanism, the machine can be put into an extreme situation during which the drive sprocket will bypass the rubber track guide holes causing a popping noise, called “cogging”.

This situation is part of the track drive systems safety design, and indicates that this portion of the safety system is functioning properly.

The “cogging” condition is most likely to occur while operating in a forward direction pulling a heavy load, and during the first 50 hours of track usage. It is caused by the tension spring being fully compressed due to high track load. If a cogging condition occurs, immediately stop machine travel and machine functions and reverse travel direction slightly to de-compress track tension. Continued cogging will cause the track drive sprocket to seat into the rubber track incorrectly, and cause damage to the track. If cogging occurs, stop travel function and check for and remove any debris or foreign matter in the drive system, check track for proper tension as shown in Section 4 of this manual, and resume operation.

### Forward Travel

Push both control levers forwards to travel straight forward. The farther these are moved, the faster the machine will travel. See **Figure 3-8**.

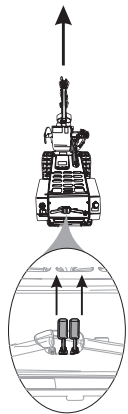

2427

Figure 3-8  
Forward Travel

### Reverse Travel

Pull both control levers backwards to travel straight backwards. The farther these are moved, the faster the machine will travel. See **Figure 3-9**.



2428

Figure 3-9 Reverse  
Travel

### Right Turn During Forward Travel

To turn to the right, move the left hand control lever farther forward than the right control lever. The farther forward the left control is moved, the faster the right turn will be made. See **Figure 3-10**.



2430  
Figure 3-10  
Right Hand Turn  
in Forward

### Left Turn During Forward Travel

To turn to the left, move the right hand control lever farther forward than the left control lever. The farther forward the right control is moved, the faster the left turn will be made. See **Figure 3-11**.

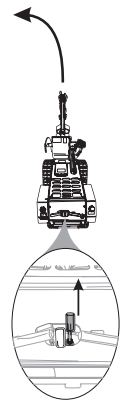

2431  
Figure 3-11  
Left Hand Turn  
in Forward

### Right Turn During Reverse Travel

Move the left hand control lever farther backward than the right control lever. The farther forward the left control is moved, the faster the right turn will be made. See **Figure 3-12**.

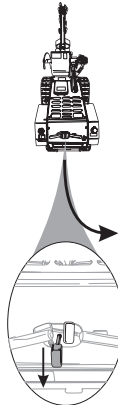

2432  
Figure 3-12  
Right Hand Turn  
in Reverse

### Left Turn During Reverse Travel

Move the right hand control lever farther backwards than the left control lever. The farther forward the right control is moved, the faster the left turn will be made. See **Figure 3-13**.

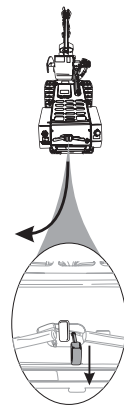

2433  
Figure 3-13  
Left Hand Turn  
in Reverse



**Spin Turn****⚠ CAUTION**

**Make sure to use the machine hand holds while doing a spin turn to maintain your balance.**

Move the travel control levers in opposite directions to spin the machine on its axis. To spin left, move the right control lever forward while pulling the left control lever backwards; to spin to the right, push the left control lever forwards and while pulling the right control lever backwards.

Figure 3-14.

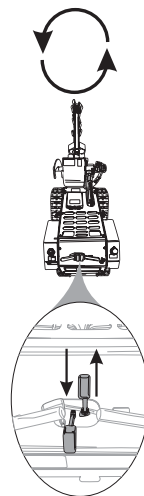

Figure 3-14 Spin Turn

2429

## ⚠ WARNING

- Do not travel up or across a slope steeper than 15°. See **Figure 3-15**.
- Keep boom as low as possible when traveling on slopes or rough terrain.

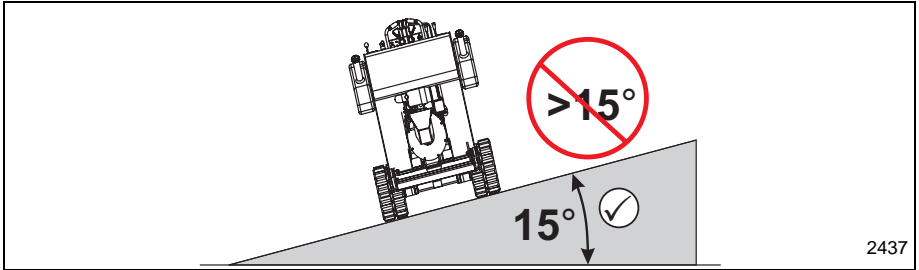

Figure 3-15 Slide Slope Travel

- Keep the heavy end of the machine towards the uphill direction when traveling up or down a slope. See **Figure 3-16**.

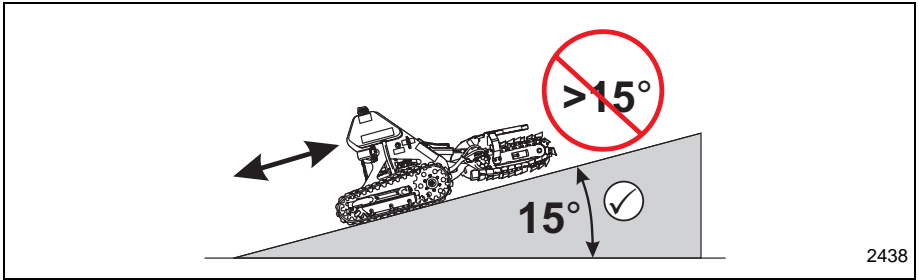

Figure 3-16 Uphill/Downhill Travel

---

## Operating Instructions

---

### **WARNING**

**BEFORE BEGINNING ANY TRENCHING, MAKE SURE THAT THE WORK AREA HAS BEEN INSPECTED AND MARKED FOR UNDERGROUND UTILITIES OR POTENTIAL OBSTRUCTIONS. ANY CONTACT WITH UNDERGROUND UTILITIES CAN POTENTIALLY CAUSE INJURY OR DEATH. CONTACT DIGGERS HOTLINE (1-800-242-8511) TO HAVE THE WORK AREA INSPECTED AND MARKED.**

---

### **CAUTION**

- **Before starting the engine, make sure that the Trencher control lever is in the NEUTRAL position and that the Trencher Operator presence control is not depressed. If this control is in either the forward or reverse position with the operator presence control depressed and the engine is started, the trencher will begin to function.**
  - **The instructions in this manual refer to a power unit that has an operator presence control that when released, that automatically shuts off the trencher, but allows the engine to continue to operate.**
- 

### **NOTICE**

Since Compact Power Inc. has no direct control over machine application or operation, following the proper safety practices is the responsibility of the owner and/or operator of the machine.

---

1. Move the engine throttle to the full speed setting.
  2. Raise the trencher boom off the ground (Item 1, [Figure 3-17](#)) and position it for use.
- 

### **CAUTION**

- **Make sure that you are standing on the operator's platform.**
  - **DO NOT step off of the platform when the chain trencher is engaged.**
  - **If you release the operator presence control, the trencher will automatically stop all motion, but the engine will continue to run.**
  - **Make sure that no other people are near the trencher chain or spoils auger during machine operation.**
-

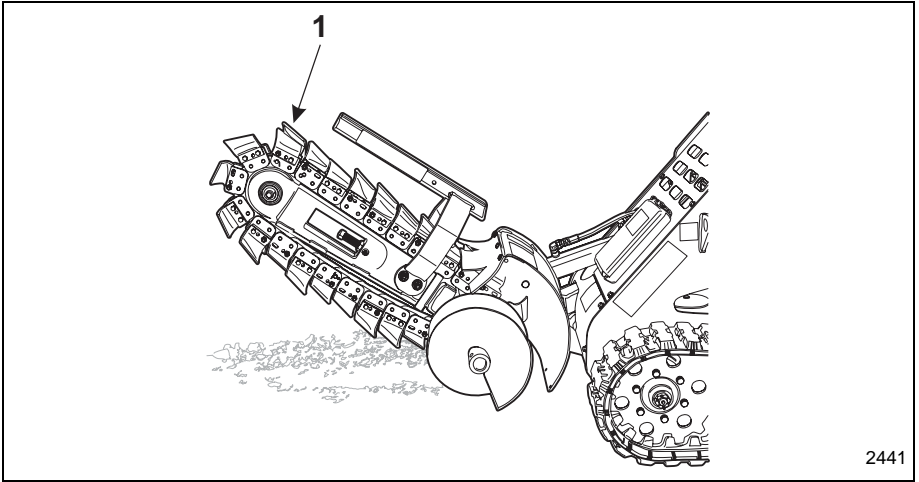

2441

Figure 3–17 Trencher Boom in Raised Position

3. Depress (step on) and hold the operator presence control (Item 1, Figure 3–18) in the “down” or activated position with your right foot.

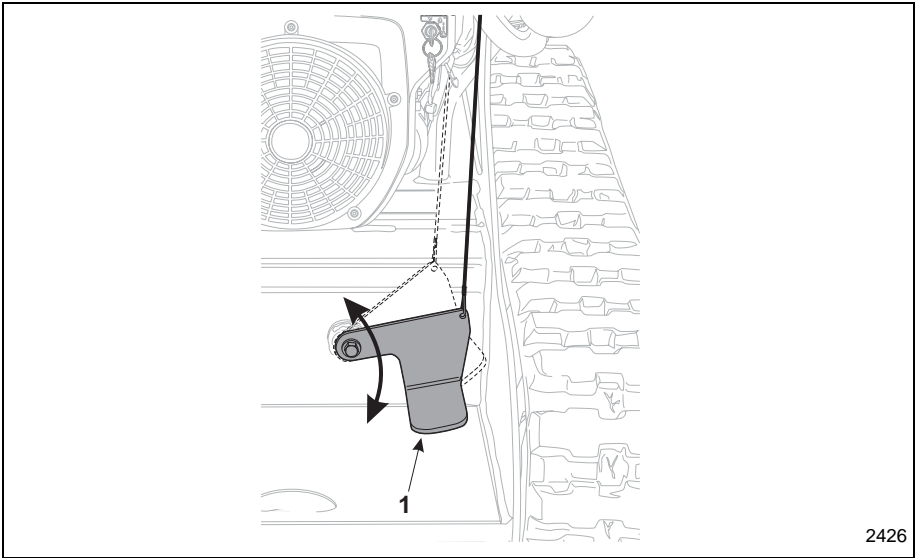

2426

Figure 3–18 Trencher Boom in Raised Position

4. With your right hand, move the trencher control lever (Item 1, **Figure 3–19**) to the right to activate the trencher chain in the FORWARD motion.

## NOTICE

The control will remain in the forward position until you either move the lever into the Neutral position or step off the operator presence control.

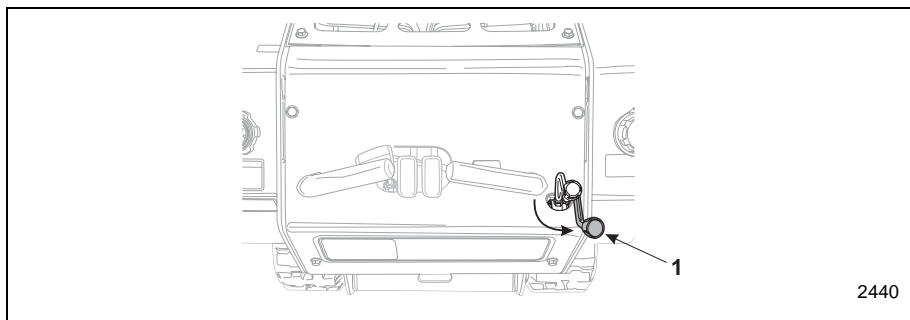

Figure 3–19 Trencher Chain Control Lever in Forward Position

5. Using the boom lower control, slowly rotate the trencher boom downwards until it makes contact with the ground. See **Figure 3–20**. Continue to slowly lower the trencher boom, but do not move the machine.

## ⚠ CAUTION

- Use extreme caution while making the initial trenching cut. Surface rocks and debris may shatter when contacted by the trencher chain.
- Keep all workers at least 10 feet from the trenching operation.

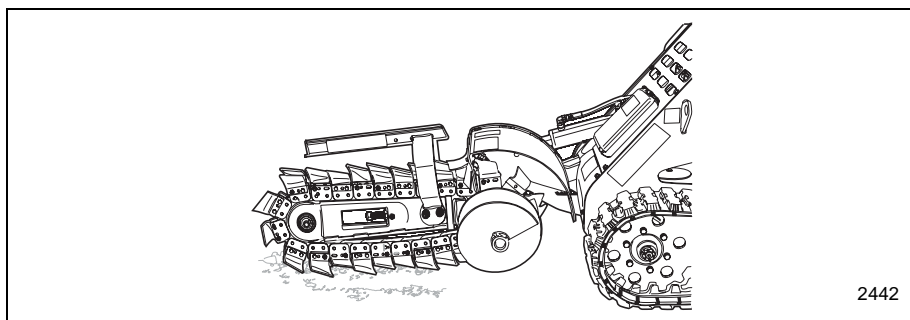

Figure 3–20 Initial Trenching Cut

- When the trencher boom (Item 1, Figure 3-21) has reached the proper digging depth the rock shield (Item 2, Figure 3-21) and spoils auger (Item 3, Figure 3-21) will direct the dirt that has been removed from the trench away from the machine.

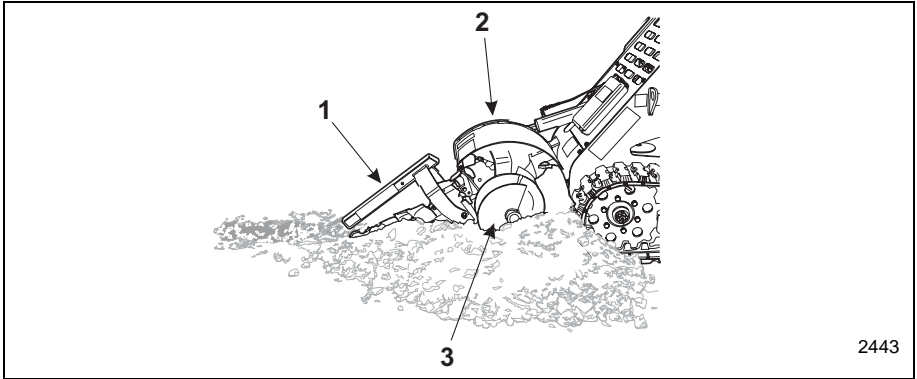

Figure 3-21 Trencher at Proper Depth

- SLOWLY** move (feather) the travel control levers rearwards to move the trencher backwards.

## CAUTION

- **DO NOT** travel backwards too fast. The trencher could become unstable.
- Use a travel speed only as fast as ground conditions will permit smooth and even trenching.

- When the travel speed has been set properly for the digging conditions, steering and direction control can be adjusted by feathering either or both of the travel control levers.
- If you want to reverse the operation of the trencher, move the auxiliary control lever (Item 1, Figure 3-22) to the left into the REVERSE position. The control lever will not remain in the REVERSE position if you release it and will return to the NEUTRAL position stopping the trencher chain.

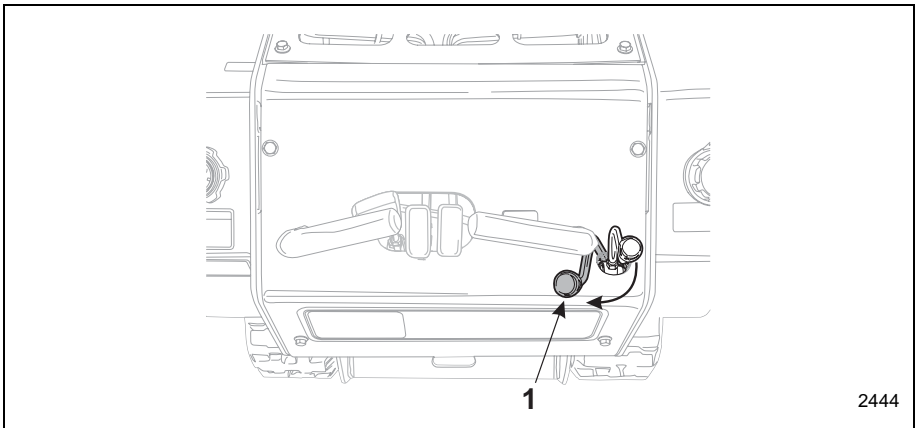

Figure 3-22 Trencher Chain Control Lever in Backwards Position

10. When all trenching has been completed, raise the trencher boom out of the trench and move the trencher out of the way.
- 

## **NOTICE**

When the trenching has been completed, move the engine throttle to the idle position and allow the engine to cool off at idle for 3 - 4 minutes.

---

11. Lower the trencher boom to the ground.
12. Shut off the engine and clean the trencher chain, tracks, and operator's platform of dirt and mud.





## Section 4 – Routine Service and Maintenance

The following information presents the routine service and maintenance required to make sure that the machine functions safely and properly. More detailed service information is contained in the Service Manual.

**Table 1: Service Cycle Table**

Activity	Daily (10 Hours)	New Machine (20 Hours)	Weekly (50 Hours)	Monthly (200 Hours)	Annual (400 Hours)
Safety Placards	✓ and R				
Fuel	✓ and R				
Engine Oil	✓ and A	R*		R**	
Engine Oil Filter		R*		R**	
Air Filter	✓			R**	R**
Fuel Filter				R**	
Engine Idle Speed					✓
Check and Clean Battery Terminals and Battery			✓	✓	
Hydraulics					
- Hydraulic Filter		R*			R**
- Hydraulic Fluid Level	✓ and A				R**
- Hydraulic Hoses	✓				
Grease	✓***				
Tracks	✓				
Visual Check for Loose/Missing Fasteners	✓				
Check and Adjust Track Tension	✓				

Service Cycle - R = Replace    ✓ = Check    A = Add

\* First 20 operational hours, then follow normal service cycle.

\*\* Extremely dusty or dirty working conditions may require more frequent service/replacement.

\*\*\*Under very wet and muddy conditions, more frequent lubrication may be required.

## Daily Maintenance Procedures

Before starting the engine, do the following pre-start service checks:

1. Check condition of all warning and instructional decals. Replace any damaged decals with genuine BOXER replacement decals.

**NOTICE:** Make sure to read and understand all WARNING and SAFETY decals before operating the machine.

2. Check engine oil

# NOTICE

The engine oil dip-stick and engine oil filler port can be reached through the top openings of the front protective cover.

- a. Make sure that the engine is OFF.
- b. Pull out the dipstick (Item 1, **Figure 4-1**) and look for both the full and add oil lines (Item 2, **Figure 4-1**) indicated by the letters “F” and “A”. The correct oil level is between those two lines.

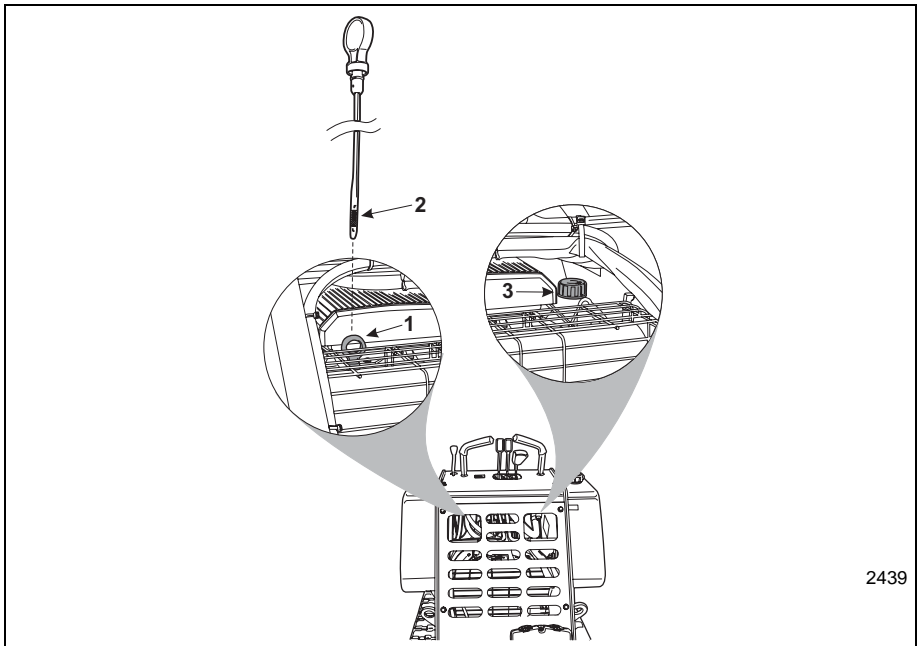

Figure 4-1 Fuel Level Check

- c. If the engine oil level is below the add line, indicated by the letter “A” on the dipstick, carefully add the proper amount of oil through the engine oil filler (Item 3, **Figure 4-1**). It is important to add the correct type of engine oil as stated in the engine manual.

## NOTICE

- Make sure to reinstall and secure the oil filler cap.
- Extremely dusty or dirty working conditions may require more frequent checking, filling and/or changing of engine oil.

## NOTICE

Make sure to securely reinstall the dipstick into the dipstick tube before starting the engine.

- d. After filling the oil, wait a few minutes and check the oil level again.

## ⚠ CAUTION

- **Allow engine to cool before filling fuel tank.**
- **Do not overfill the fuel tank. Fuel could spill onto hot engine parts and ignite or explode.**

3. The Boxer has one saddle fuel tank (Item 1, **Figure 4-2**). The tank has a fuel gauge (Item 3, **Figure 4-2**) located in the filler cap (Item 2, **Figure 4-2**). Remove cap and visually inspect fuel level to make sure that the indicator is showing the proper fuel level. Make sure that the tank has been filled on a daily basis. Carefully add fuel.

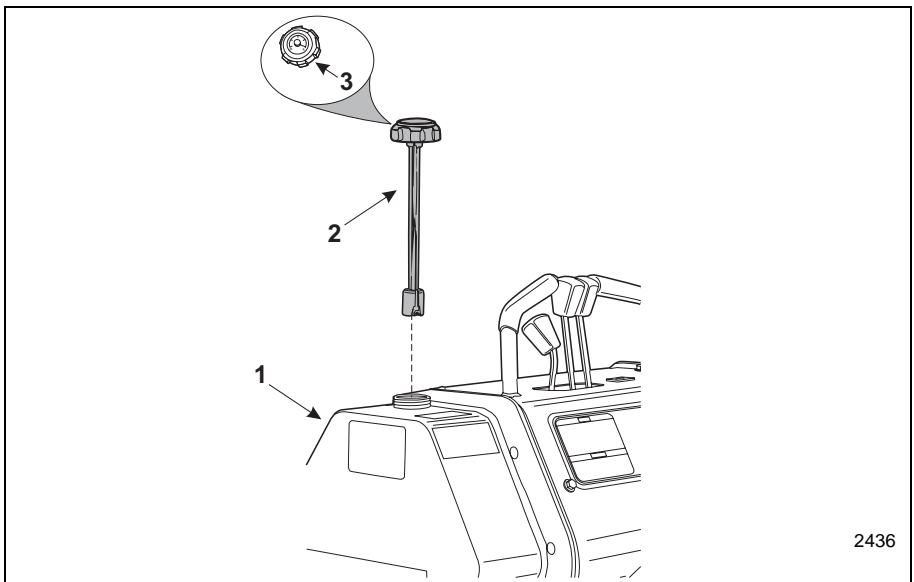

Figure 4-2 Fuel Level Check

2436

4. Check Air Filter

- a. Reach underneath the control panel plate to access the top of the engine.
- b. Remove the air filter cover (Item 1, **Figure 4-3**) and inspect the outer air filter sleeve (Item 4, **Figure 4-3**). The outer air filter sleeve will trap only the largest dirt particles. Remove the air filter sleeve and clean as needed.
- c. If the sleeve is dirty, loosen and remove the wing nut (Item 2, **Figure 4-3**) holding the air filter top plate (Item 3, **Figure 4-3**).
- d. Remove and inspect the main air filter (Item 5, **Figure 4-3**). If the air filter is dirty, replace the filter and outer air filter sleeve with a genuine BOXER repair part.

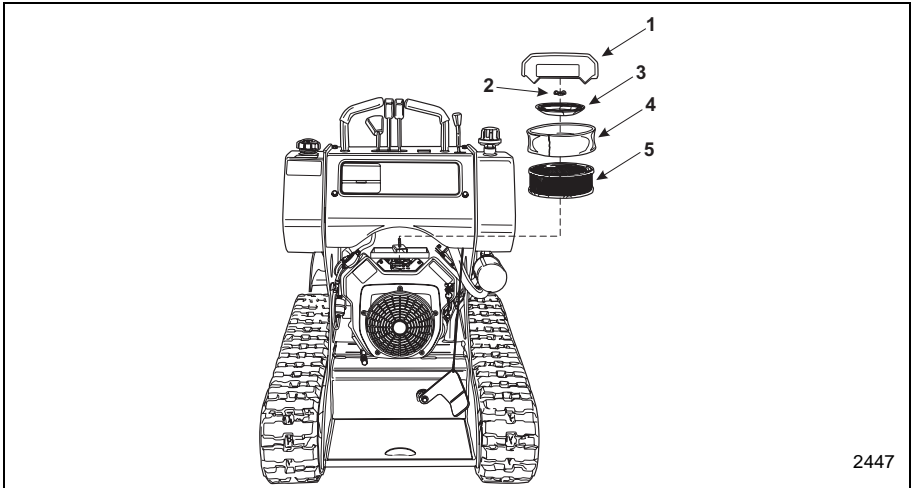

Figure 4-3 Air Filter Assembly

## NOTICE

Extremely dusty or dirty working conditions may require more frequent service/replacement.

5. Check all hydraulic hoses, lines and fittings.

## ⚠ WARNING

**Hydraulic oil under pressure can penetrate body tissue causing serious injury and possible death. When troubleshooting a hydraulic system for leaks, always use cardboard or wood as a detector. DO NOT USE YOUR BARE HANDS. If you are injected with hydraulic oil or any other fluids, immediately seek treatment by a doctor trained in the treatment of penetrating fluid injuries.**

- Visually inspect all of the hydraulic hoses, lines and fittings for signs of damage, wear or leaking.
- If any signs of damage are visible, do not operate the machine until repairs have been made.
- Some examples of common hydraulic hose damage are shown in **Figure 4-4**.

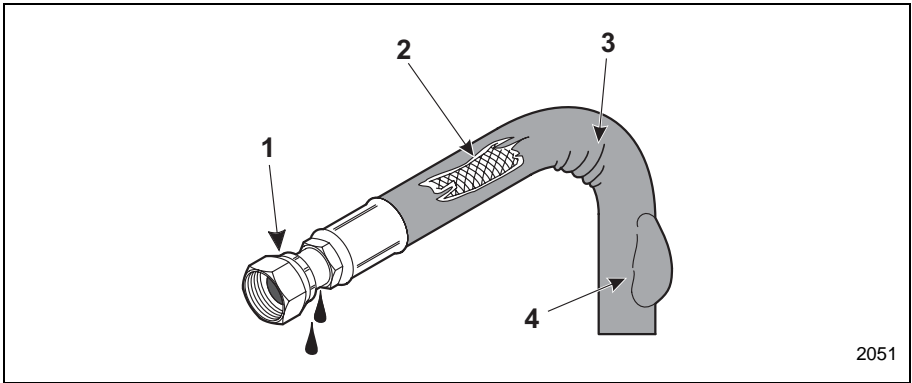
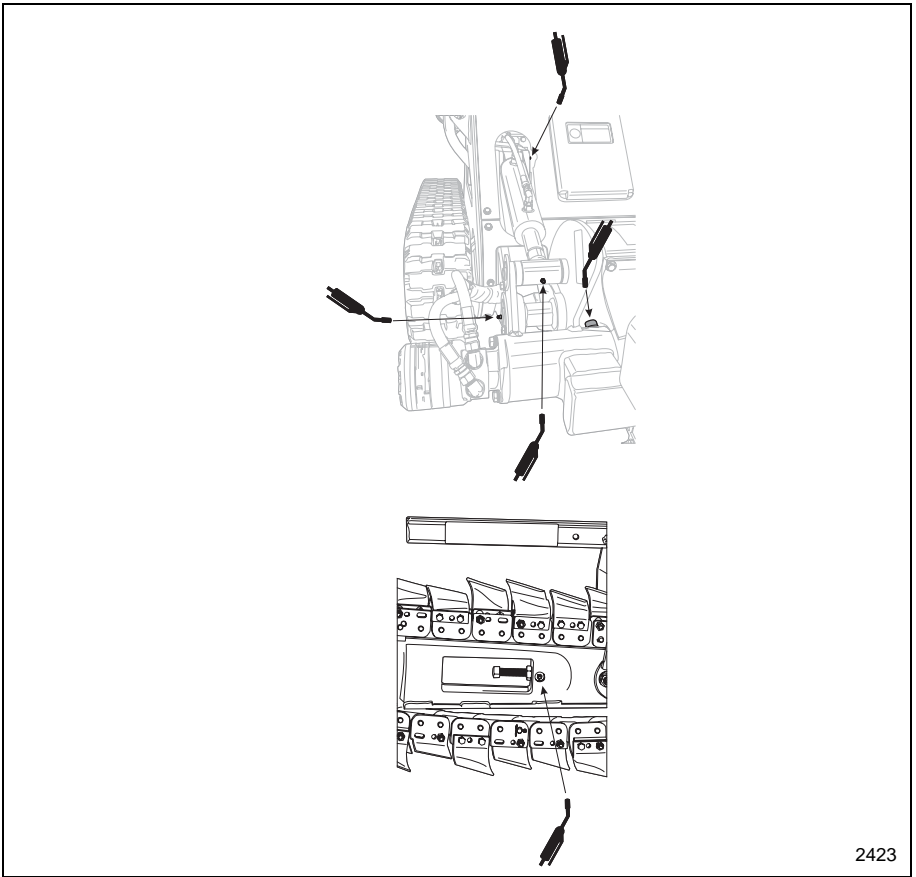

Figure 4-4 Hydraulic Hose Damage

1. End fittings damaged or leaking
  2. Outer covering chafed or cut, and wire reinforcing is exposed
  3. Hose shows signs of kinking or crushing
  4. Outer covering ballooning
6. Check for loose or missing fasteners
    - a. Inspect for any loose or missing bolts.
    - b. Tighten or replace any missing bolts immediately.
  7. While you are performing the daily maintenance, inspect the machine for any signs of damage, such as missing or damaged components, cracked welds, etc.
  8. Check the track assemblies to make sure that:
    - a. The tracks are in good condition and are not showing any signs of wear.
    - b. Track tension is properly set.
    - c. Track drive motors are not leaking oil or hydraulic fluid.
  9. Grease pivot shafts with proper type of grease. There are 5 grease points on this machine, see [Figure 4-5](#).

## NOTICE

The grease zerk below the chain tension bolt should only be greased monthly.



2423

Figure 4-5 Grease Zerk Locations

10. Check for proper track tension.

- a. Remove the track adjusting wrench (Item 2, **Figure 4-6**) from the right track assembly. Make sure that the rubber grommets (Item 3, **Figure 4-6**).

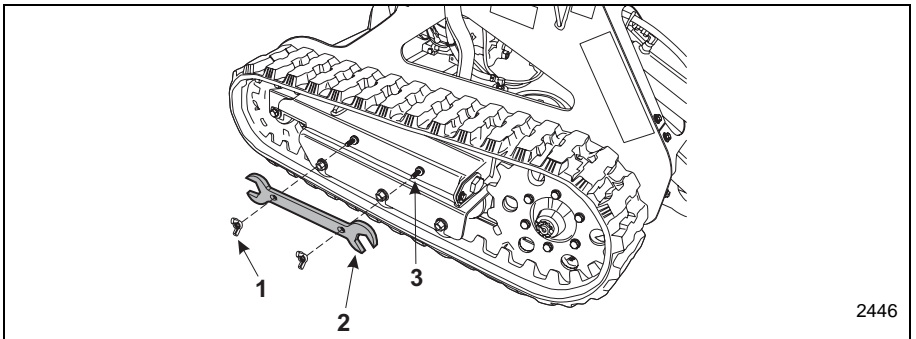

2446

Figure 4-6 Track Adjustment Wrench Storage

- b. Place a solid object, such as a concrete block or 8" H x 8" W x 48" L piece of lumber, under the operator's platform.
- c. Tilt the trencher boom downwards until the lowest cutting edge is touching the ground. See Figure 4-6.
- d. Continue to lower the boom assembly, pushing the front of the machine upwards. Continue raising the machine until the front drive sprocket and rear idler rollers are off the ground. Shut off the engine.
- e. Measure the gap between the bottom of the center bogey guide roller (Item 1, Figure 4-6) and the track. The proper tension will be about a 1/4" - 3/8" deflection.
- f. If an adjustment is needed, remove the adjustment nut lock plate and rotate the tension adjustment nut (Item 2, Figure 4-6) until the proper track deflection measurement is achieved. Reinstall and secure the adjustment nut lock plate.
- g. With the tracks still off the ground, start the engine and rotate just the track being adjusted three or four times in both forward and reverse. Shut off the engine after rotating the track.

## ⚠ WARNING

**DO NOT activate either the trencher operator presence control or trencher operation lever while testing the track assembly. This could cause an unstable condition on the machine.**

- h. Shut off the engine and re-measure the deflection dimension.
- i. Repeat the measurement and adjustment procedure on the other track assembly.
- j. Lower the machine onto the ground.

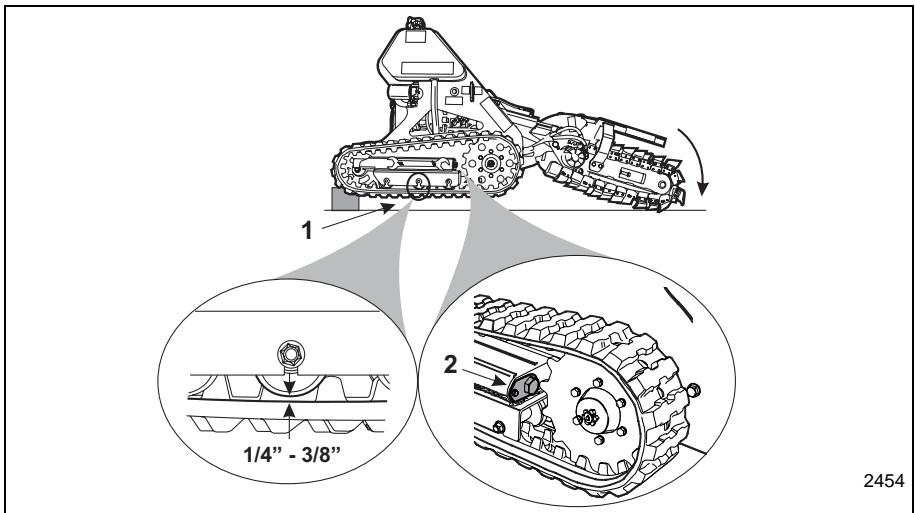

Figure 4-7 Track Deflection Measurement and Adjustment

## ⚠ CAUTION

Before starting the engine:

- Move all hydraulic control levers forward and release the lever. Make sure that each lever automatically returns to the Neutral position.
- Move all hydraulic control levers rearward and release the lever. Make sure that each lever automatically returns to the Neutral position.
- Step on the trencher operator presence control and shift the Trencher Control Lever to the right into the trenching position. The control lever should remain in that position as long as the operator presence control is held down. Releasing the operator presence control returns the Trencher Control Lever to the neutral position.
- If any of the levers, other than the Trencher Control Lever, do not automatically return to the Neutral position, **DO NOT** use the machine until repairs have been completed.

## NOTICE

Extremely dusty or dirty working conditions may require more frequent service/replacement.

### New Machine Brake-in Maintenance Procedures

Do the following after the first 20 operating hours for a new machine only.

1. Change engine oil - see engine manual.
2. Change engine oil filter, which is located on the left side of the engine - see engine manual and (Item 1, [Figure 4-8](#)).

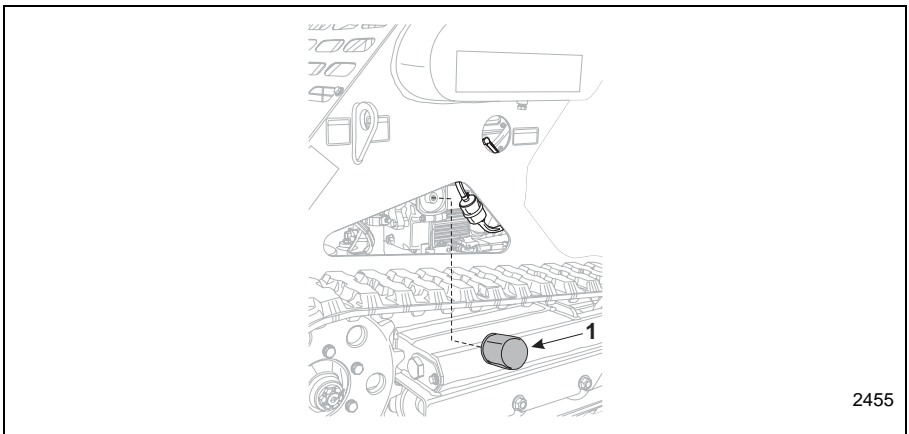

Figure 4-8 Engine Oil Filter



3. Change the hydraulic filter. See Service Manual and **Figure 4-9**.

## **⚠ CAUTION**

- **The hydraulic filter will be filled with hydraulic fluid. Make sure to dispose of the used hydraulic filter in an appropriate manner and according to State and Local regulations.**
- **Make sure to dispose of the used hydraulic fluid in an appropriate manner and according to State and Local regulations.**
- **Place a container under the upper hydraulic tank to capture any hydraulic fluid that may drain out.**

- a. Remove the hydraulic filter (Item 2, **Figure 4-9**) from the filter mount (Item 1, **Figure 4-9**) underneath the hydraulic tank.
- b. Using a small amount of hydraulic oil, lubricate the rubber gasket on top of the new filter canister and install the filter onto the filter mount.

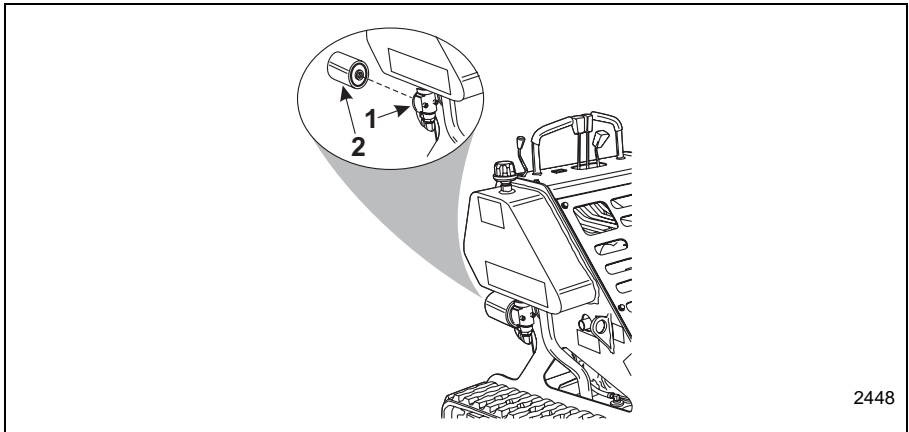

Figure 4-9 Hydraulic Oil Filter

- c. Start and run the engine for about 30 seconds. Using the hydraulic oil level dip stick (Item 1, **Figure 4-10**), check the hydraulic oil level. Add the appropriate hydraulic fluid as needed through the filler port (Item 2, **Figure 4-10**) on top of the upper hydraulic oil tank (Item 3, **Figure 4-10**).

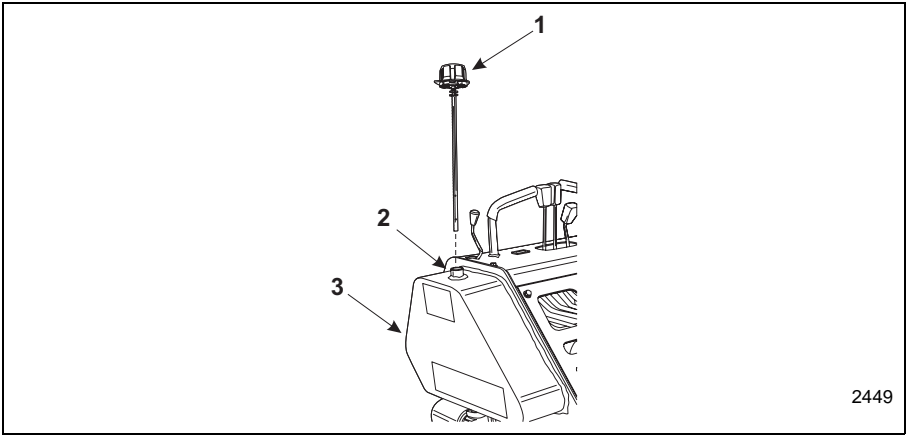

Figure 4-10 Hydraulic Oil Check and Fill

## Weekly Maintenance Procedures

Do the following procedures weekly or every 50 operating hours:

1. Do all Daily maintenance procedures

Check the battery (Item 3, **Figure 4-11**) and cable connections (Items 1 and 2, **Figure 4-11**) for signs of leaking, corrosion or damage. To complete this check, remove the service access panel.

# NOTICE

Make sure that the battery clamp (Item 4, **Figure 4-11**) is securely holding the battery in position.

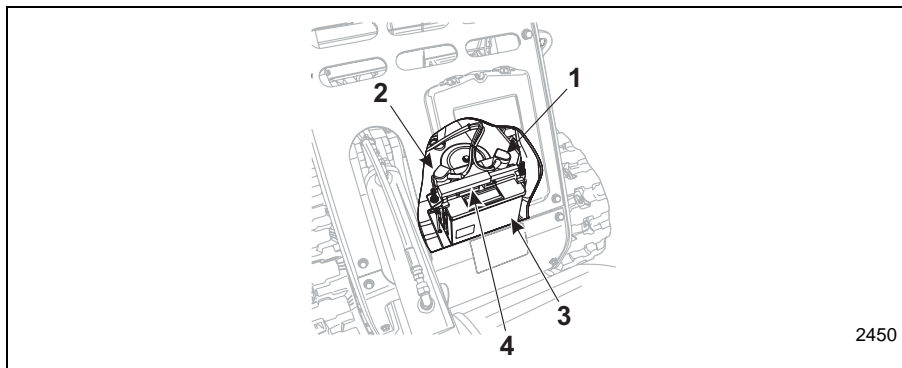

2450

Figure 4-11 Battery and Cable Connections

## Monthly Maintenance Procedures

Do the following procedures monthly or every 200 operating hours:

1. Do all Daily and Weekly maintenance procedures
2. Replace engine oil and engine oil filter - see engine manual
3. Replace air Filter.
  - a. Reach underneath the control panel plate to access the top of the engine.
  - b. Remove the air filter cover (Item 1, **Figure 4-12**) and the outer air filter sleeve (Item 4, **Figure 4-12**).
  - c. Loosen and remove the wing nut (Item 2, **Figure 4-12**) holding the air filter top plate (Item 3, **Figure 4-12**).
  - d. Remove and replace the filter (Item 5, **Figure 4-12**), and outer air filter sleeve (Item 4, **Figure 4-12**) with a genuine BOXER repair parts.

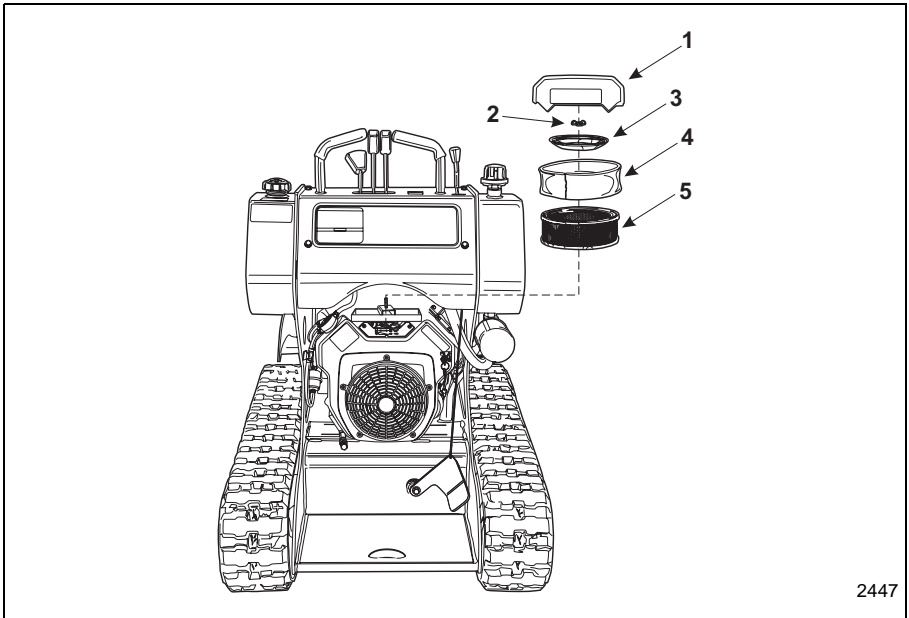

Figure 4-12 Air Filter Assembly

## NOTICE

Extremely dusty or dirty working conditions may require more frequent service/replacement.

---

#### 4. Replace fuel filter.

---



## DANGER

- **GASOLINE IS VERY FLAMMABLE. HANDLE WITH EXTREME CAUTION.**
  - **MAKE SURE THAT THE ENGINE HAS BEEN ALLOWED TO COOL BEFORE PERFORMING THIS OPERATION.**
  - **MAKE SURE THAT THERE ARE NO OPEN FLAMES IN THE WORK AREA.**
  - **ONLY PERFORM THIS PROCEDURE IN AN AREA WITH PROPER VENTILATION.**
  - **DO NOT SMOKE WHILE PERFORMING THIS OPERATION.**
  - **CLEAN UP ANY SPILLED FUEL BEFORE STARTING THE ENGINE.**
- 

- a. Locate fuel filter assembly (Item 2, [Figure 4-13](#)) along the left side of the engine.
  - b. Shut off fuel using the fuel shut off valve (Item 1, [Figure 4-13](#)) by rotating the valve handle horizontally across the fuel line.
  - c. Remove the spring clamps (Item 3, [Figure 4-13](#)) from above and below the fuel filter (Item 2, [Figure 4-13](#)) and remove the fuel lines.
  - d. Replace the fuel filter with a new filter.
- 



## NOTICE

- **The old fuel filter will be filled with gasoline. Make sure to drain the fuel from the filter into an appropriate container.**
  - **Dispose of the used fuel filter in an appropriate manner and according to State and Local regulations.**
- 

- e. Install and secure the fuel lines and reopen the fuel valve.

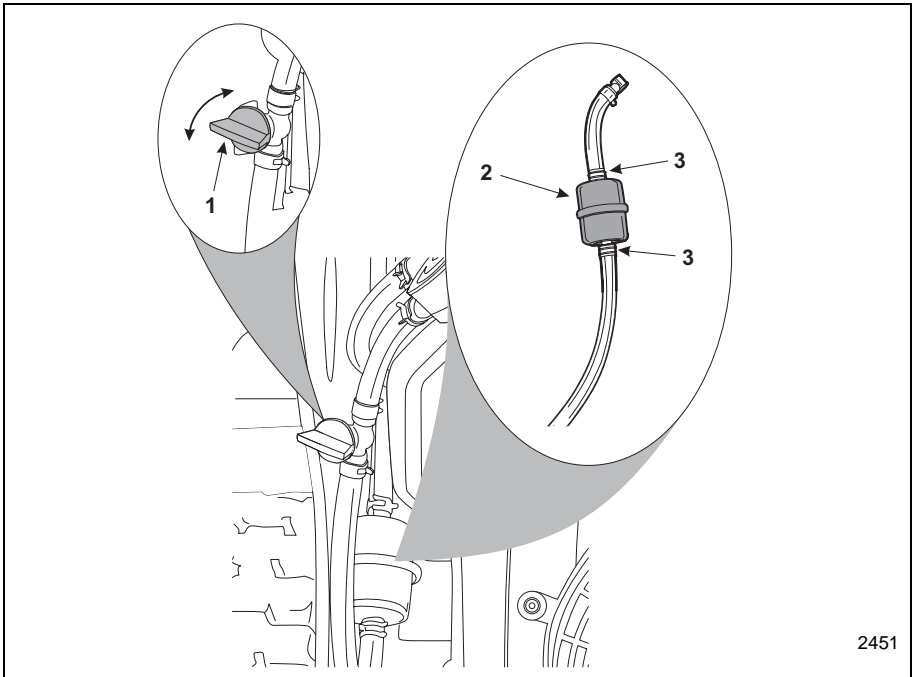

Figure 4-13 Fuel Filter Replacement

## ⚠ CAUTION

**Make sure to clean up any spilled fuel from in and around the engine compartment of the machine. Spilled fuel may be ignited by a hot engine.**

5. Check battery signs of leakage or for corrosion on the battery cables.
  - On a monthly basis, check the battery (Item 8, [Figure 4-14](#)) for signs of leaking electrolyte. If any signs of damage are visible, remove and replace the battery.

## ⚠ CAUTION

**Wear the proper protective clothing when handling the battery. Leaking battery fluid contains acid that can cause burns. Fumes from the leaking fluid can cause respiratory problems.**

6. To prevent corrosion, spray on a battery protectant and sealer onto both terminals and cable clamps after cables are installed.
7. The electrical system on this machine is a **NEGATIVE** ground system.
8. Remove the service access panel to access the battery and cables.
9. Check both of the battery cables (Items 5 and 6, [Figure 4-14](#)) for signs of damage or corrosion.

10. Loosen the cable clamps and remove the cable from the battery. Clean the terminals with a battery brush. Reinstall and secure the cable clamps.
11. Check the battery hold down clamp (Items 4 and 7, **Figure 4-14**) to make sure that the battery is being held securely to the machine.

## NOTICE

If the battery needs to be replaced, make sure to dispose of the old battery according to local regulations.

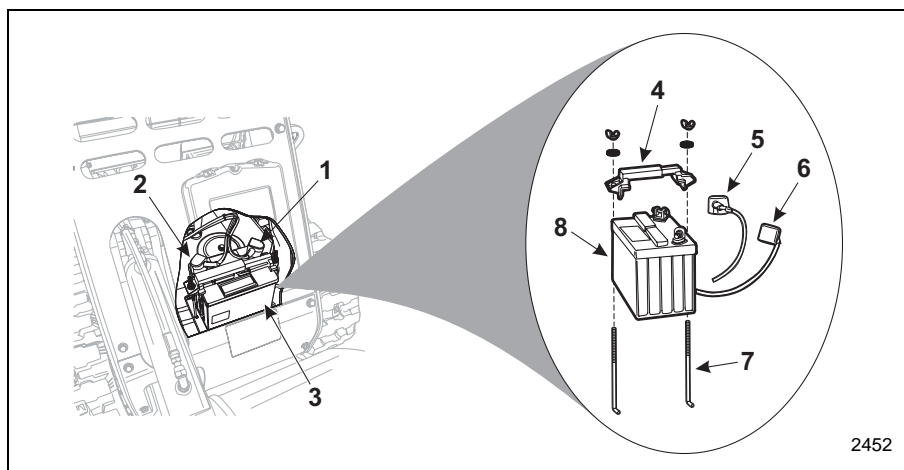

Figure 4-14 Battery and Connections

## Annual Maintenance Procedures

Do the following procedures annually:

1. Do all Daily, Weekly and Monthly maintenance procedures
2. Replace air filter. See [page 4-12](#), Step 3.
3. Check engine idle speed (Refer to engine manual)
4. Replace hydraulic fluid.
  - a. Place a suitable sized container at the left front corner of the Boxer.
  - b. Remove the hydraulic tank drain plug (Item 1, [Figure 4-15](#)) and drain all hydraulic fluid from the machine.

## NOTICE

Make sure to inspect the O-ring (Item 2, [Figure 4-15](#)) on the drain plug. Replace the O-ring if any signs of damage are noted.

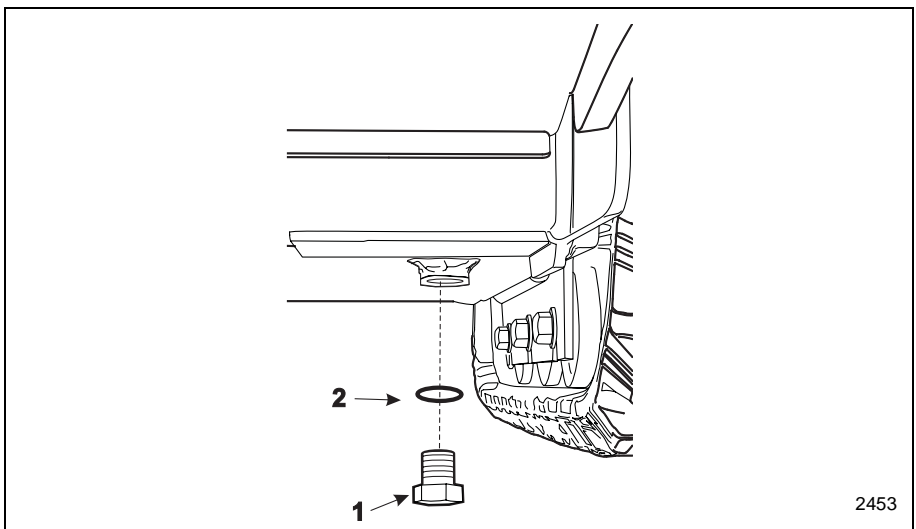

Figure 4-15 Hydraulic Tank Drain Plug

- c. When all of the hydraulic fluid has drained out of the tank, reinstall and secure the drain plug.

## NOTICE

- Make sure to dispose of the used hydraulic fluid in an appropriate manner and according to State and Local regulations.
- The hydraulic filter will be filled with hydraulic fluid. Make sure to dispose of the used hydraulic filter in an appropriate manner and according to State and Local regulations.



d. Replace hydraulic filter. See [page 4-9](#), Step 3.

## NOTICE

The hydraulic dipstick is located underneath the hydraulic filler cap, located on top of the upper hydraulic tank. See [Figure 4-16](#).

- e. Unscrew the dipstick assembly and remove from the machine. (1, [Figure 4-16](#)) and fill the hydraulic tank with the proper hydraulic fluid (Chevron Rykon Premium ISO 46 or equivalent) until the fluid level is at but not above the upper marker hole in the dipstick. Do not over fill the hydraulic system. Damage to the hydraulic system might result.
- f. Start the machine and run the engine at low idle for several minutes. Shut off the engine.
- g. Recheck the hydraulic fluid level as described above.

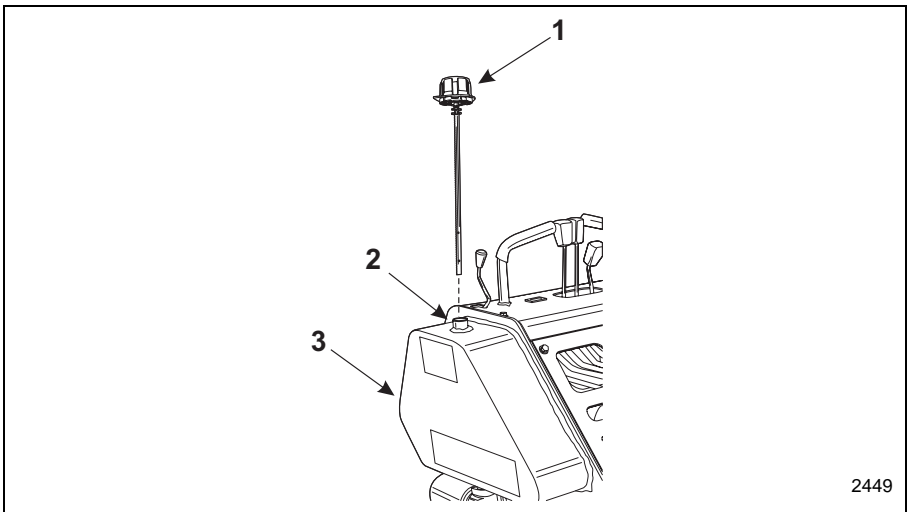

Figure 4-16 Hydraulic Oil Check and Fill

2449

## General Maintenance

### Draining Fuel Tank

**! DANGER**

1. **GASOLINE IS EXTREMELY FLAMMABLE AND HIGHLY EXPLOSIVE.**
- 2) **A FIRE OR EXPLOSION FROM GASOLINE CAN BURN YOU OR OTHERS AND CAUSE PROPERTY DAMAGE.**
- 3) **DRAIN FUEL FROM TANKS WHEN THE ENGINE IS COLD.**
- 4) **FUEL TANKS SHOULD ONLY BE DRAINED IN AN AREA THAT IS WELL VENTILATED.**
5. **WIPE UP ANY GASOLINE THAT SPILLS.**

1. Park the machine on a level surface, to make sure that the fuel tank is completely drained.
2. Lower the trencher boom and stop the engine and remove the key.
3. Allow the engine to cool completely.
4. Shut off fuel using the fuel shut off valve (Item 1, [Figure 4-17](#)) by rotating the valve handle horizontally across the fuel line.

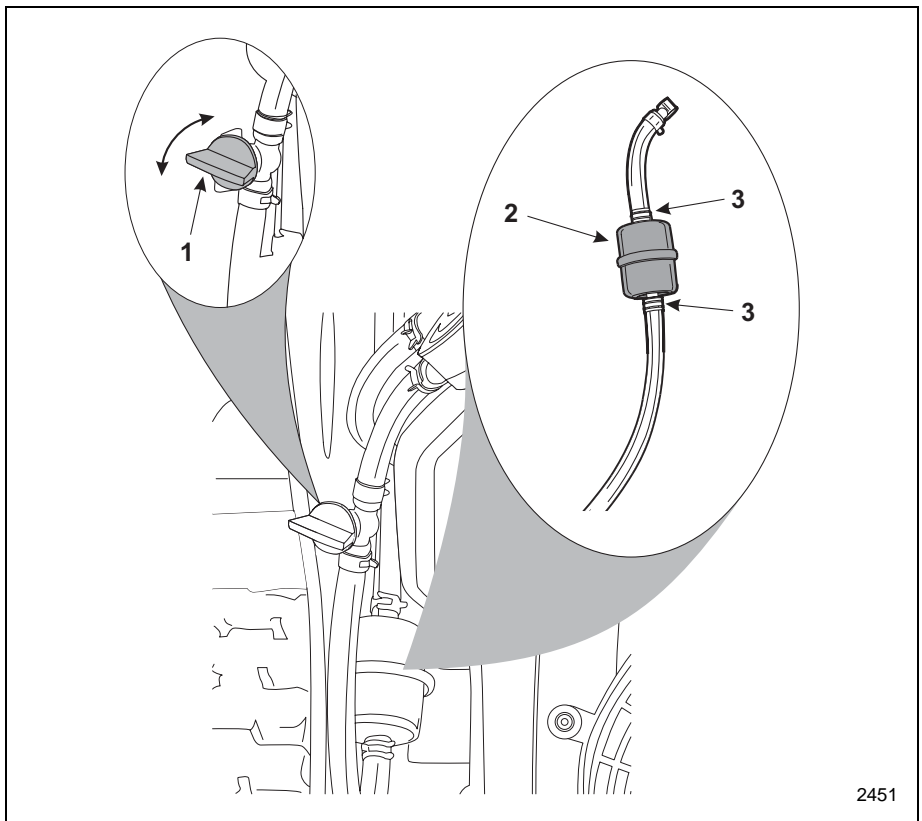

2451

Figure 4-17 Fuel Shut Off Valves

5. Loosen the lower intake hose clamp (Item 3, **Figure 4-17**) at the fuel filter (Item 2, **Figure 4-17**). Slide the clamp along the fuel line (Item 3, **Figure 4-17**), away from the filter.
6. Pull the fuel line off of the fuel filter and position the line in a suitable sized container.

---

## NOTICE

The fuel tank holds approximately 3 gallons of fuel.

---

7. Open the fuel valve (Item 1, **Figure 4-17**) and allow the fuel to drain into the drain container.
8. Remove the upper hose clamp from the fuel filter (Item 3, **Figure 4-17**) and install a new fuel filter (Item 2, **Figure 4-17**) as described earlier in this section.

---

## NOTICE

- The old fuel filter will be filled with gasoline. Make sure to drain the fuel from the filter into an appropriate container.
  - Dispose of the used fuel filter in an appropriate manner and according to State and Local regulations.
- 
9. When the fuel has fully drained, close the fuel valve and install the lower fuel line onto the new fuel filter.
  10. Slide the hose clamp close to the fuel filter to secure the fuel line.
  11. Fill the fuel tank with fresh fuel.
  12. Open the fuel valve.
  13. Start the engine and allow it to idle for several minutes to make sure that all air bubbles are out of the fuel system.

---

## CAUTION

- **Make sure to clean up any spilled fuel from in and around the engine compartment of the machine.**
  - **Spilled fuel may be ignited by a hot engine.**
-

## Adjusting Digging Chain Tension

Adjust the digging chain tension every 25 operating hours. With the trencher parallel to the ground, make sure that there is 1¾" to 2" of chain sag between the bottom of the boom and the top of the bottom chain span. See **Figure 4-18**.

# NOTICE

- For a new chain, check the chain sag after the first hour of operation.
- Depending on working conditions, chain sag adjustments may need to be done more frequently.

If a chain sag adjustment is needed, adjust the chain using the following procedure:

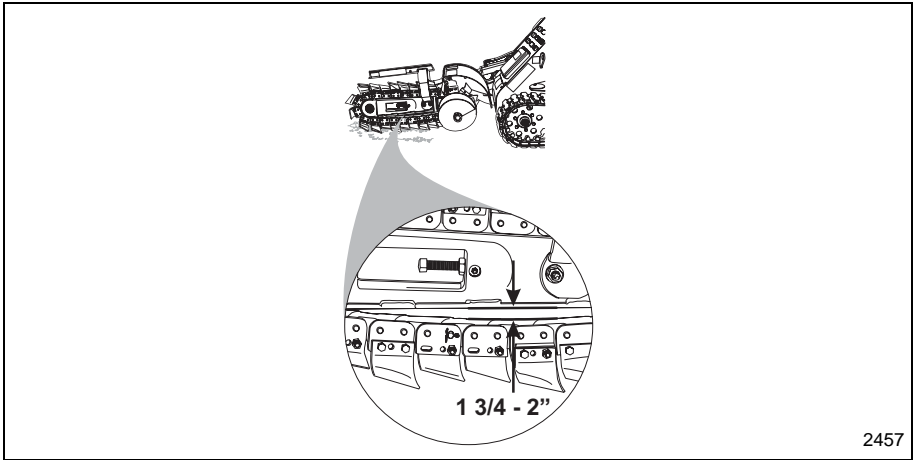

Figure 4-18 Chain Sag

# NOTICE

Do not over tighten the chain. Excess chain tension may damage drive components.

If the chain tension needs to be adjusted:

1. Loosen the adjustment bolt lock nut (Item 2, **Figure 4-19**)
2. Rotate the chain adjustment bolt (Item 3, **Figure 4-19**) to increase or decrease pressure on the boom until the proper chain sag is measured.
3. Tighten the adjustment bolt lock nut.
4. On a monthly basis, lubricate the adjustment bolt using the grease zerk (Item 1, **Figure 4-19**).

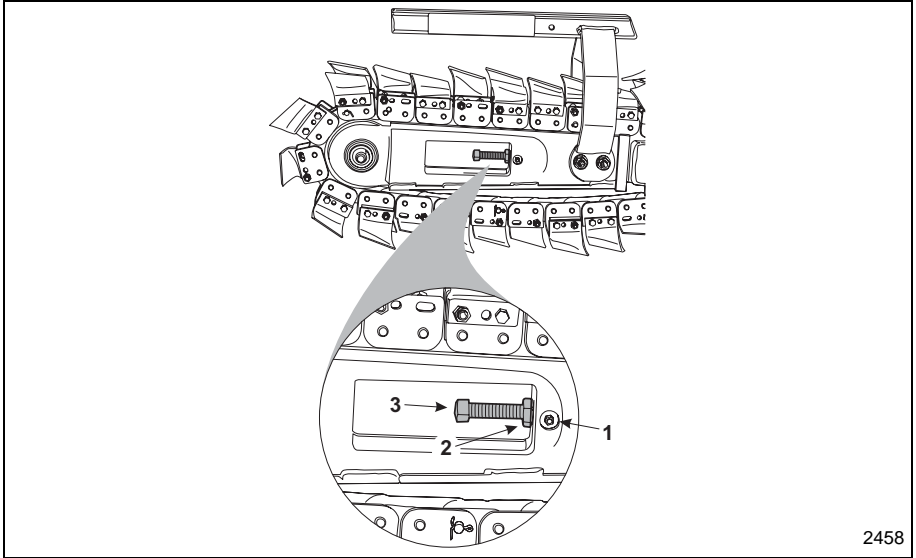

Figure 4-19 Chain Tension Adjustment

2458

## Trencher Boom Replacement

Adjust the digging chain tension every 25 operating hours. With the trencher parallel to the ground, make that there is 1¾" to 2" of chain sag between the bottom of the boom and the top of the bottom chain span. See [Figure 4-20](#).

---

# NOTICE

For this procedure, raise the trencher off the ground a short distance to make working on it easier.

---

# ⚠ CAUTION

**Make sure to shut off the machines engine and remove the key from the ignition.**

---

Inspect the bottom of the boom for wear, if it is worn, complete the following:

---

# NOTICE

Some parts in [Figure 4-20](#) have been removed for clarity.

---

1. Remove the boom guard (Item 1, [Figure 4-20](#)) from the boom assembly.
2. Loosen the Chain Tension Adjustment Bolt lock nut (Item 5, [Figure 4-20](#)) and Chain Tension Adjustment Bolt (Item 4, [Figure 4-20](#)) to fully release the chain tension.
3. Remove the chain from the boom tip sprocket. The trencher chain does not need to be fully removed for this procedure.
4. Slide the boom assembly (Item 3, [Figure 4-20](#)) forward and off the trencher frame (Item 7, [Figure 4-20](#)).
5. Flip the boom assembly over so the bottom becomes the top. If the boom assembly has already been flipped, replace it with a certified BOXER replacement part.
6. Slide the boom assembly back onto the main trencher frame tube.
7. Reinstall the chain onto the trencher nose roller.
8. Adjust the chain tension following the "Adjust the Digging Chain Tension" instruction listed earlier in this manual.
9. Tighten the lock nut (Item 5, [Figure 4-20](#)) to secure the tension adjustment bolt (Item 4, [Figure 4-20](#)) in position.

10. Reinstall the boom guard (Item 1, Figure 4-20)

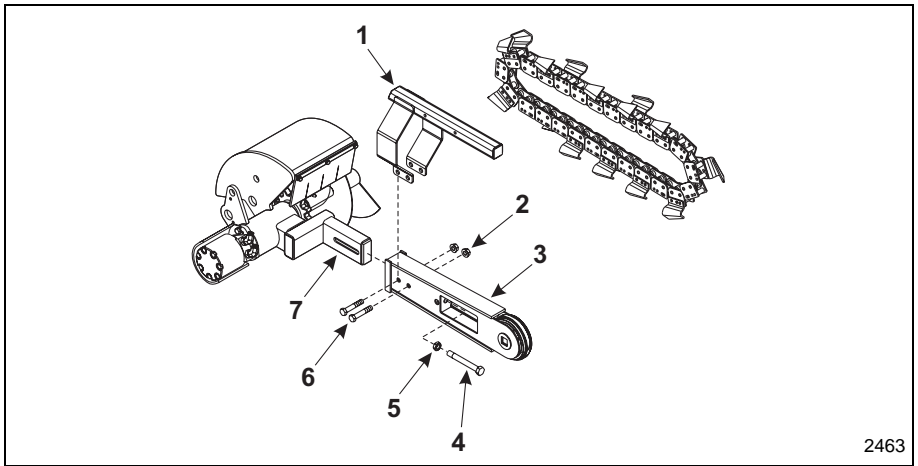

Figure 4-20 Trencher Boom Assembly

## Replacing the Digging Teeth

Due to the high amount of wear placed on the digging teeth, you will need to replace them periodically. To replace a single tooth (Items 3 and 5, [Figure 4-20](#)), remove the bolts and nuts (Item 1 and 2, [Figure 4-21](#)) securing the tooth to remove it, and then install a new tooth in the same position.

# NOTICE

The spacer tubes (Item 4, [Figure 4-21](#)) will fall free. Make sure to reinstall these when the new tooth is installed.

Torque the bolts securing the teeth to 27 to 33 ft.-lb.

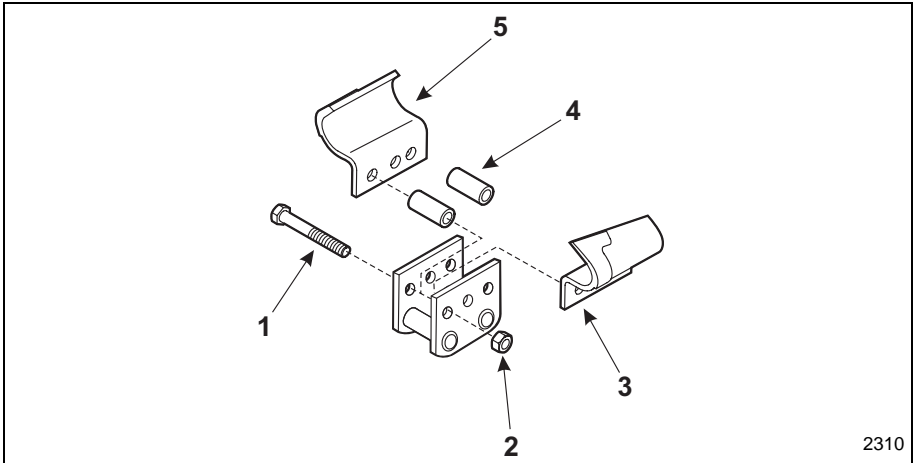

Figure 4-21 Tooth Replacement



## Replacing the Drive Sprocket

Overtime, the drive sprocket will wear, especially when used in sandy or clay soils. When this happens, the digging chain will begin to slip. If the chain slips, replace the drive sprocket, as follows:

1. Raise the trencher a few inches above the ground.
2. Stop the engine and remove the key.
3. Remove the spoils auger (Item 1, [Figure 4-22](#)).
4. Loosen the chain tensioning bolt lock nut (Item 14, [Figure 4-22](#)) and then rotate the chain tensioning bolt (Item 13, [Figure 4-22](#)) to loosen the trencher chain, until you can remove the chain from the boom.
5. Remove the chain (Item 2, [Figure 4-22](#)) from the drive sprocket (Item 4, [Figure 4-22](#)) by removing the master link pivot pin. See Chain Master Link later in this section.
6. Remove and discard the old drive sprocket, making sure to keep the drive key (Item 3, [Figure 4-22](#)).
7. Clean the sprocket mounting surface on the trencher.
8. Slide the new sprocket onto the drive shaft, align the key ways and insert the key locking the sprocket to the shaft.

---

## NOTICE

Inspect the trencher boom for signs of wear. If excessive wear is noted, flip the boom over or replace it as needed. See Trencher Boom Replacement earlier in this section.

---

9. Loop the chain over the auger drive shaft and onto the drive sprocket, making sure that the teeth point forward on the upper span.

10. Install the spoils auger and secure it using the nut removed earlier.
11. Set the upper span of the chain into place on the trencher boom, and then wrap the chain around the roller at the end of the boom. Connect the chain together as shown in the “Chain Master Link” on page 28 for instructions.
12. Tighten the chain tension adjustment bolt until the proper chain tension is set according to the Adjusting Digging Chain Tension instructions shown earlier in this section.

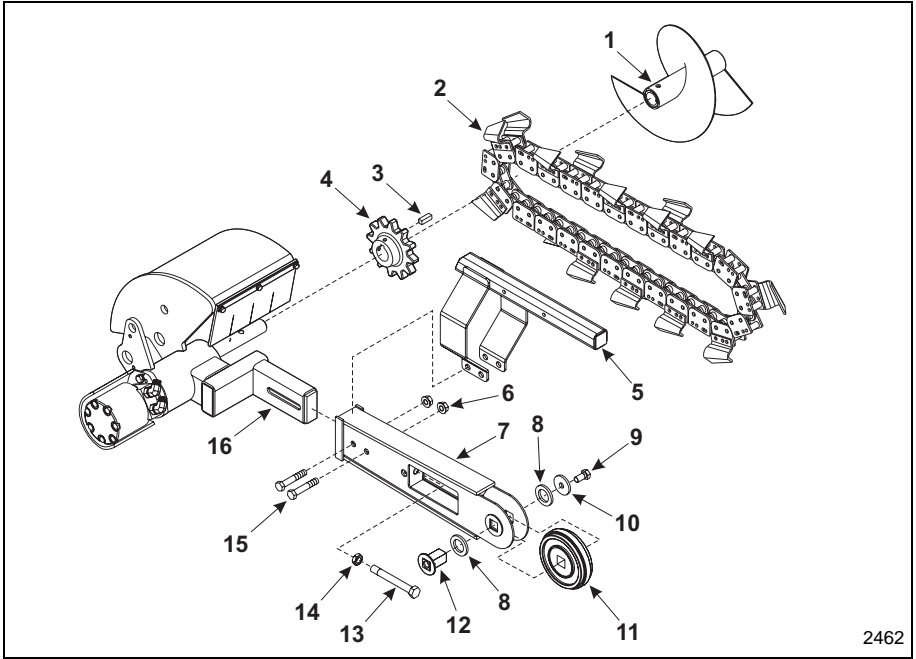

Figure 4–22 Replacing Drive Sprocket

## Chain Configuration

You can set up the chain in different configurations, depending on the width of the trench desired and the soil conditions at the work site. Depending on the size of boom you purchased, you will either have a chain with:

- 24 links (24 inch [60.9 cm] boom)
- 32 links (36 inch [91.4 cm] boom)

Each link can have digging teeth fastened to it and are referred to as a station. At any station, the teeth can be fastened in various configurations with spacers and tubes to vary the width of cut. The station configurations are placed along the chain in an order that maximizes digging efficiency.

There are two types of teeth, cupped and triangular rock teeth. Cupped teeth are designed to cut through and remove soil. Triangular rock teeth cut rock and other hard ground. The teeth are cupped or angled differently depending on which side of the chain they are intended to be fastened (i.e., either left or right). The teeth are fastened to the chain links using bolts, nuts, tubes, and spacers of varying sizes. **Figure 4–23** illustrates the various components of several tooth configurations.

The table on the following page lists some of the chain configurations, detailing which tooth configuration should be installed at each station around the chain for each chain configuration.

## NOTICE

Each table lists the configurations for 32 positions. If you are changing the configuration of a 24 link chain, ignore the positions 25 through 32 in the tables.

- Make sure to orient the tooth in the proper direction. **Figure 4–23** shows the rear of the tooth. If the tooth is installed backwards, the trencher chain will not work properly.

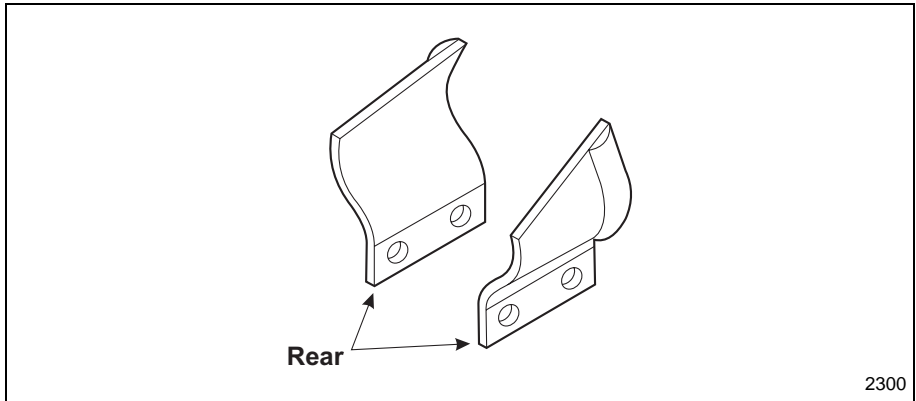

Figure 4–23 Tooth Direction

## Chain Master Link

If the trencher chain needs to be removed from the trencher, it can be broken at the Master Link.

# ⚠ CAUTION

**When the Master Link is removed, the chain could fall off the trencher frame. Keep your hands and feet from underneath the chain to prevent injury.**

To separate the Master Link:

1. Inspect the chain and locate the master link (Item 1, [Figure 4-24](#)), which will have a removable pivot pin and cotter pin instead of two bolts.
2. Support the trencher chain from underneath the trencher frame.
3. Remove the cotter pin (Item 2, [Figure 4-24](#)) from the pivot pin (Item 3, [Figure 4-24](#)) and then remove the pivot pin.
4. Remove the spacer tube (Item 4, [Figure 4-24](#)) from the chain links (Item 5, [Figure 4-24](#)).
5. Using an appropriate lifting device, remove the trencher chain from the trencher frame.
6. Replace the trencher chain and reassemble the master link by reversing Steps 1-5.

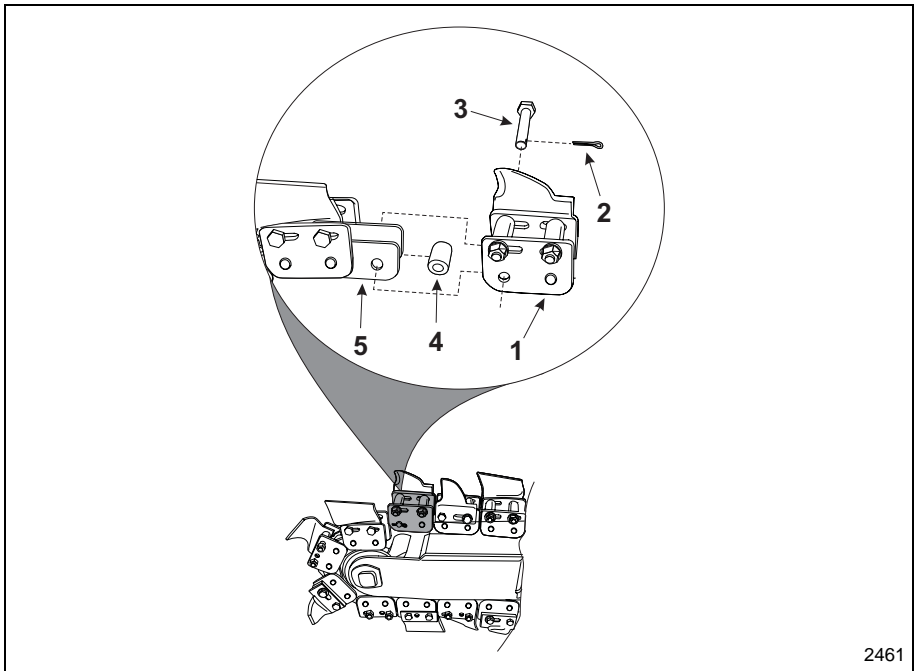

Figure 4-24 Master Link

2461

---

## Configuring the Chain

To configure the chain, complete the following procedures:

Select the chain configuration you want to install from the chain configuration illustrations (Configurations A - E, **Figure 4-22**) and obtain all necessary parts.

1. Lower the trencher boom, stop the engine, and remove the key.
2. Remove the unneeded teeth and other hardware from the links on the top span of the chain.

---

### NOTICE

When removing teeth, keep the components of each tooth set together so you can assemble them later.

- 
3. Install each tooth set across the top span from front to back, in the order listed in the appropriate chain configuration table.

---

### NOTICE

Install the tooth configuration illustrated for station 1 first, followed by the tooth configuration for station 2, and so on.

- 
4. Torque the bolts to 27 to 33 ft.-lb.
  5. When all positions are installed on the top span, start the engine, raise the trencher slightly off the ground using the trencher boom, and slowly run the chain forward to expose a new section of chain.
  6. Stop the engine and remove the key.
  7. Repeat steps 3 through 7 until all chain positions have been changed.

## Parts List

<b>Trencher Chain Parts list</b>			
<b>Item #</b>	<b>Description</b>	<b>Quantity</b>	<b>Part #</b>
1	BOLT, 3/8"-24 X 2 1/4	"12	38242148
2	BOLT, 3/8"-24 X 2 3/4	"24	38242348
3	BOLT, 3/8"-24 X 3	"8	382438
4	BOLT, 3/8"-24 X 2 1/2	"12	38242128
6	BOLT, 3/8"-24 X 3 3/4	"8	38243348
8	LOCK NUT	64	3824
9	FLAT WASHER	16	382S
10	SPACER TUBE, 1 3/8	"52	B135320
11	LEFT TERMINATOR TOOTH	8	T165404L
12	RIGHT TERMINATOR TOOTH	8	T165404R
13	LEFT CUP TOOTH	8	6655760
14	RIGHT CUP TOOTH	8	6655759
15	SPACER TUBE, 1 1/4	"12	6576368
16	FLAT SPACER	4	BL1654-6
17	FLAT SPACER	4	BL1654-5

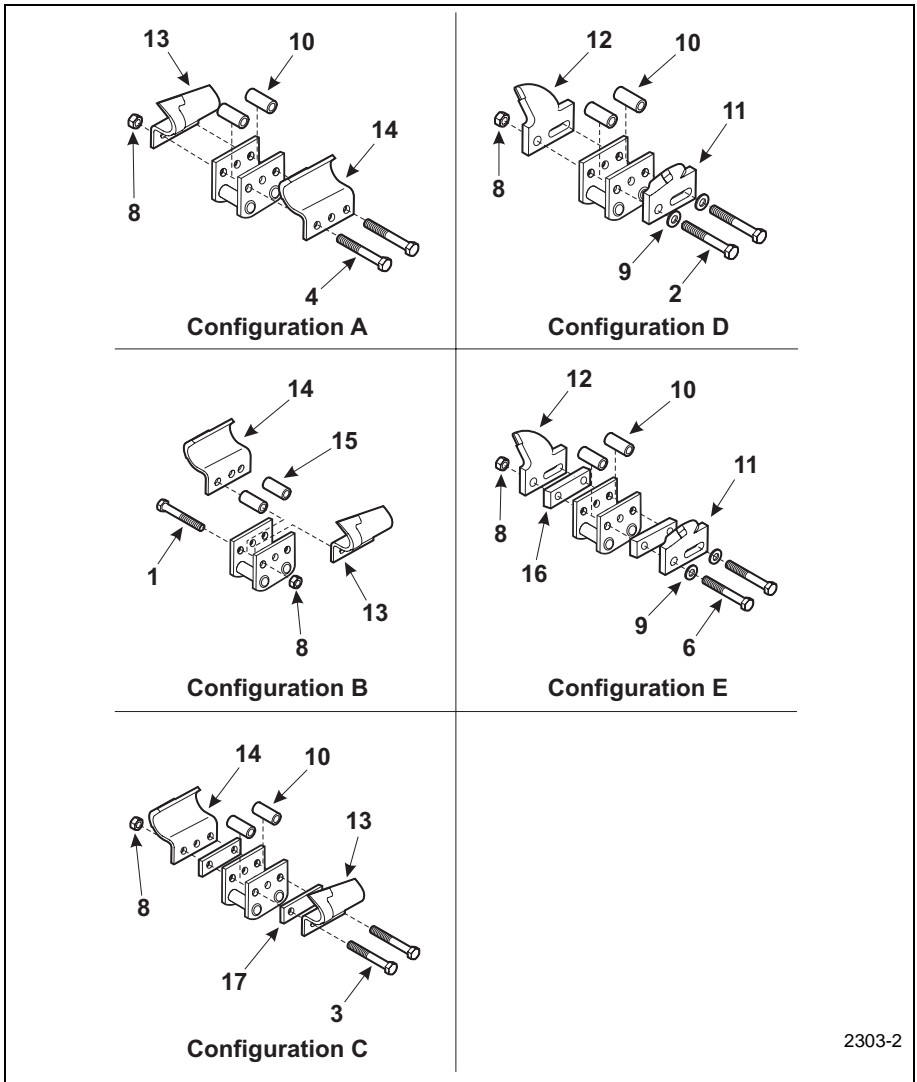

2303-2

Figure 4-25 Chain Configuration

# Boxer 118 Hydraulic Interconnect Diagram

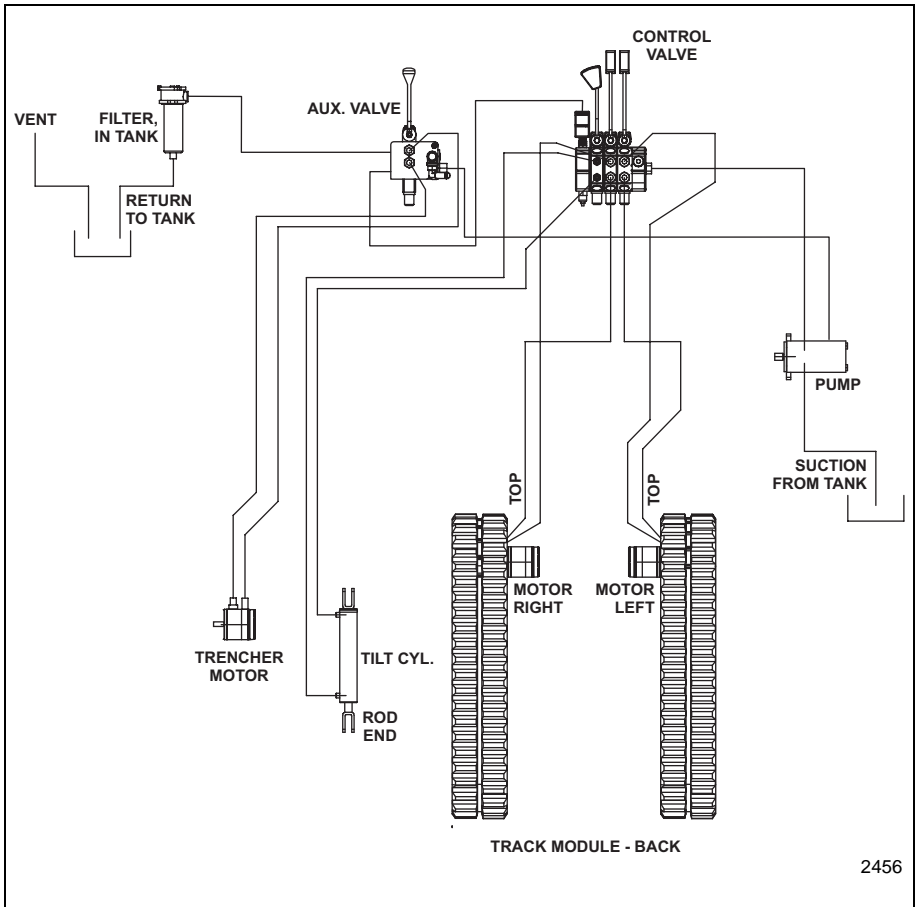

2456

Figure 4-26 Boxer 118 Hydraulic Interconnect Diagram



# Section 5 – Troubleshooting

The following procedures will assist you in determining the potential cause of a machine operating problem.

Problem	Possible Causes	Corrective Action
Starter does not turn the engine over.	<ul style="list-style-type: none"> <li>Trencher control lever is either in Forward or Reverse position and the operator presence control is depressed.</li> </ul>	<ul style="list-style-type: none"> <li>Move lever to neutral position.</li> <li>Release operator presence control.</li> </ul>
	<ul style="list-style-type: none"> <li>Battery is dead.</li> </ul>	<ul style="list-style-type: none"> <li>Charge the battery.</li> <li>If battery does not hold a charge, replace the battery.</li> </ul>
	<ul style="list-style-type: none"> <li>Electrical connections are corroded or loose.</li> </ul>	<ul style="list-style-type: none"> <li>Check electrical connections for good contact.</li> <li>Remove cables from battery terminals and fully clean battery terminals and cable clamps.</li> <li>If the cable clamps cannot be properly cleaned, replace connectors.</li> </ul>
	<ul style="list-style-type: none"> <li>Relay or starter switch is defective.</li> </ul>	<ul style="list-style-type: none"> <li>Contact Authorized Service Dealer.</li> </ul>
	<ul style="list-style-type: none"> <li>Engine is in hydraulic lock due to a cylinder filled with fuel.</li> </ul>	<ul style="list-style-type: none"> <li>Allow engine to cool before attempting this procedure.</li> <li>Remove spark plugs and turn engine over to pump excess fuel from engine cylinder.</li> <li>Make sure to clean up any spilled fuel before attempting to start the engine.</li> </ul>
Engine will not start, starts hard, or fails to keep running.	<ul style="list-style-type: none"> <li>Trencher control lever is not in neutral position.</li> </ul>	<ul style="list-style-type: none"> <li>Move lever to neutral position.</li> </ul>
	<ul style="list-style-type: none"> <li>Fuel tank is empty.</li> </ul>	<ul style="list-style-type: none"> <li>Fill fuel tank with fuel.</li> </ul>
	<ul style="list-style-type: none"> <li>Air cleaner is dirty.</li> </ul>	<ul style="list-style-type: none"> <li>Clean air filter housing and replace the filter elements.</li> </ul>
	<ul style="list-style-type: none"> <li>Spark plug dirty or fouled.</li> </ul>	<ul style="list-style-type: none"> <li>Replace spark plug.</li> </ul>
	<ul style="list-style-type: none"> <li>Dirty or contaminated fuel filter.</li> </ul>	<ul style="list-style-type: none"> <li>Replace fuel filter.</li> </ul>
	<ul style="list-style-type: none"> <li>Dirt, water, or stale fuel is in fuel system.</li> </ul>	<ul style="list-style-type: none"> <li>Drain fuel in tanks into an appropriate storage container and dispose of bad fuel properly.</li> <li>Refill fuel tanks with fresh, clean fuel.</li> <li>Replace fuel filter.</li> </ul>
	<ul style="list-style-type: none"> <li>15 Amp fuse blown.</li> </ul>	<ul style="list-style-type: none"> <li>Replace fuse.</li> </ul>

Problem	Possible Causes	Corrective Action
Engine loses power.	<ul style="list-style-type: none"> <li>• Engine load is excessive.</li> </ul>	<ul style="list-style-type: none"> <li>• Reduce ground speed.</li> <li>• Reduce speed of trencher.</li> </ul>
	<ul style="list-style-type: none"> <li>• Air cleaner is dirty.</li> </ul>	<ul style="list-style-type: none"> <li>• Clean air filter housing and replace the filter elements.</li> </ul>
	<ul style="list-style-type: none"> <li>• Engine oil level in crankcase is low.</li> </ul>	<ul style="list-style-type: none"> <li>• Add the appropriate engine oil to crankcase. See engine manual for oil specifications.</li> </ul>
	<ul style="list-style-type: none"> <li>• Cooling fins and air passages under engine blower housing are plugged.</li> </ul>	<ul style="list-style-type: none"> <li>• Remove obstruction from cooling fins and air passages.</li> </ul>
	<ul style="list-style-type: none"> <li>• Dirty or contaminated fuel filter.</li> </ul>	<ul style="list-style-type: none"> <li>• Replace fuel filter.</li> </ul>
	<ul style="list-style-type: none"> <li>• Dirt, water, or stale fuel is in fuel system.</li> </ul>	<ul style="list-style-type: none"> <li>• Drain fuel in tank into an appropriate storage container and dispose of bad fuel properly.</li> <li>• Refill fuel tank with fresh, clean fuel.</li> <li>• Replace fuel filter.</li> </ul>
Engine overheats.	<ul style="list-style-type: none"> <li>• Engine load is excessive.</li> </ul>	<ul style="list-style-type: none"> <li>• Reduce ground speed.</li> <li>• Reduce speed of trencher.</li> <li>• Engine oil level in crankcase is low.</li> <li>• Add the appropriate engine oil to crankcase. See engine manual for oil specifications.</li> </ul>
	<ul style="list-style-type: none"> <li>• Cooling fins and air passages under engine blower housing are plugged.</li> </ul>	<ul style="list-style-type: none"> <li>• Remove obstruction from cooling fins and air passages.</li> </ul>
Abnormal engine vibration.	<ul style="list-style-type: none"> <li>• Engine mounting bolts are loose.</li> </ul>	<ul style="list-style-type: none"> <li>• Tighten engine mounting bolts.</li> </ul>
With the engine turned off, the boom creeps downward (less than 3" per hour is normal for this machine).	<ul style="list-style-type: none"> <li>• Valve spool leakage.</li> </ul>	<ul style="list-style-type: none"> <li>• Contact Service Dealer.</li> </ul>
	<ul style="list-style-type: none"> <li>• Cylinder seals are leaking.</li> </ul>	<ul style="list-style-type: none"> <li>• Replace cylinder seals.</li> </ul>
With the engine turned off, boom drops downward quickly and then stops.	<ul style="list-style-type: none"> <li>• Cylinder seals are leaking.</li> </ul>	<ul style="list-style-type: none"> <li>• Replace cylinder seals.</li> </ul>

Problem	Possible Causes	Corrective Action
The machine does not travel in either forward or reverse directions.	• Engine is not running at full speed.	• Advance throttle to full engine speed.
	• Hydraulic fluid is cold.	• Fully warm hydraulic fluid.
	• Hydraulic fluid level is low.	• Check and fill the hydraulic fluid tank with the appropriate hydraulic fluid.
	• Fuel tank is empty and engine stops.	• Fill fuel tank with fuel.
	• If all above has been checked.	• Contact authorized service dealer.
Trencher chain does not turn	• Trencher control lever not in the proper position.	• Move trencher control lever in the activation position.
	• Operator presence control not depressed.	• Depress (step on) operator presence control.
	• Engine not at rated speed.	• Move throttle to maximum RPM setting.
	• Power unit is low on hydraulic fluid.	• Refer to power units Operator's Manual
	• Trencher Chain drive motor is leaking hydraulic fluid.	• Replace hydraulic auger drive motor.
Trencher Chain rotates, but not smoothly or stops and starts.	• Soil may contain rocks or other items that are preventing smooth operation.	• Raise trencher chain from the trench to clear contact with the obstruction.
	• Power unit is low on hydraulic fluid.	• Check and fill the hydraulic fluid tank with the appropriate hydraulic fluid.
	• Trencher hydraulic drive motor is failing.	• Replace hydraulic drive motor.
Hydraulic drive motor is turning but the spoils auger does not move	• Spoils auger connection bolt not installed.	• Install and secure connection bolt.
	• Spoils auger connection bolt has sheared off.	• Install and secure connection bolt.
Hydraulic fluid is leaking from trencher drive motor.	• Hydraulic fitting loose.	• Tighten hydraulic fittings.
	• Internal hydraulic motor seals leaking.	• Replace hydraulic drive motor.
Engine starts but does not continue to run when using trencher.	• Too much downward force is being applied to trencher, stalling engine.	• Raise trencher slightly.
	• Power unit low on fuel.	• Refuel power unit.
Poor trencher performance, does not penetrate soil easily.	• Worn trencher chain teeth.	• Replace worn trencher teeth
	• Not enough down pressure on trencher.	• Increase downward pressure on the trencher.



## Section 6 – General Specifications

<b>Engine System</b>				
Type	Kohler Command Pro			
Cooling System	Air Cooled			
HP / KW	18 / 13.4			
Fuel Tank	3.0 Gallons			
Air Cleaner	Standard Air Cleaner			
<b>Hydraulic System</b>				
Reservoir Capacity	13 gallons			
Filter	10 Micron			
<b>Electrical System</b>				
Battery	12 Volt			
<b>Control System</b>				
Starting	Keyed ignition switch.			
Throttle/Choke	Engine Mounted			
Steering	Two spring centered control lever with zero turning type controls.			
<b>Warranty</b>				
Engine Warranty	Two Year			
Product Warranty	One Year			
<b>Ground Drive System-Dimensions</b>				
Units	English		Metric	
Trench Depth	24 - 36	in.	610 - 914	mm
Trench width	4 - 8	in.	101 - 203	mm
Boom travel up	60 Degrees			
Boom travel down	61 Degrees			
Length (Boom Travel Position)	82	in.	2082.8	mm
Width	35	in.	889	mm
Height	49	in.	1245	mm
Wheel Base	32	in.	813	mm
Ground Speed Forward	200	ft/Min.	61	M/Min.
Ground Speed Reverse	70	ft/Min.	21.3	M/Min.
Chain Speed	280	ft/Min.	7112	M/Min.
Trench center to outside left	15.5	in.	394	mm
Trench center to outside right	19.5	in.	495	mm
Total Weight	1652	lbs	749	kg

## Noise Data

Tests were performed in accordance with EU Machinery Directive 98/37/EC EN 474-10:2006 in addition to ISO/DIS 6394:2004. Engine RPM was @ 3600 rpm (max) rpm. The noise measurements were made with the operator present.

The declared value for the operator is 77 dB ( $L_A$ ).

The Guaranteed SWL value is 107 dB ( $L_{WA}$ ).

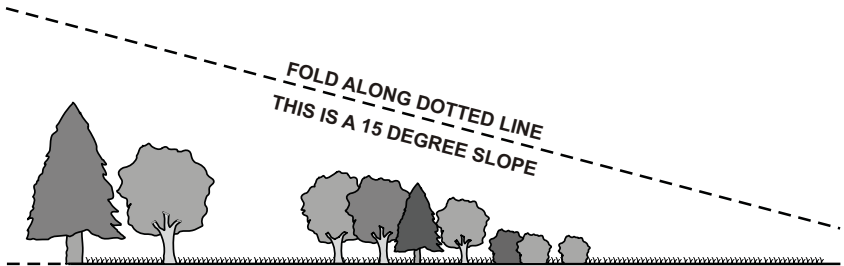

DO NOT TRAVEL ACROSS OR UP AND DOWN A SLOPE GREATER THAN 15 DEGREES.

## SUGGESTED GUIDE FOR SIGHTING SLOPES FOR SAFE OPERATION OF A COMPACT UTILITY LOADER WITH AN ATTACHMENT.

DO NOT REMOVE THIS PAGE FROM THE MANUAL.

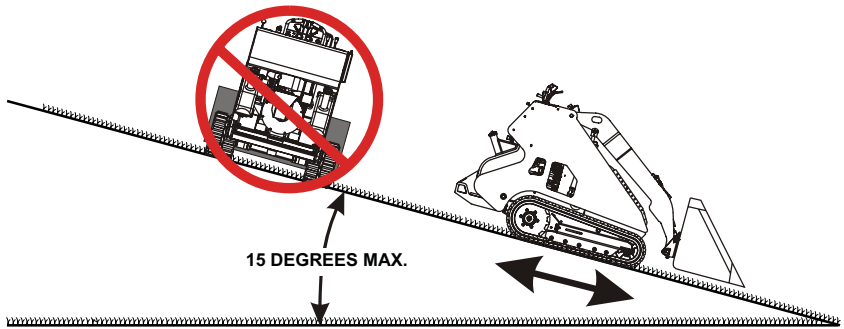

### **⚠ WARNING**

- To avoid serious injury, operate your unit up and down the face of slopes.
- Travel across slopes with great caution.
- Do not operate on slopes greater than 15 degrees.
- Make turns gradually to prevent tipping or loss of control.
- Exercise extreme caution when changing direction on slopes.
- Control of the machine may be affected by installed attachments.
- Reduce travel speed on slopes.
- Read and understand all Warnings and Operating Instructions in the Operator's Manual.

1. Fold this page along dotted line indicated above. DO NOT remove the page from the manual.
2. Hold page before you so that its left edge is vertically parallel to a tree trunk or other upright structure.
3. Sight across the fold in the direction of the hill slope you want to measure.
4. Compare the angle of the fold with the slope of the hill.



---

Compact Power Inc.  
P.O. Box 40 – Fort Mill, SC 29716

Phone: 800-476-9673 – Fax: 803-548-2762  
Web Site: <http://www.cpiequipment.com/>



## Free Manuals Download Website

<http://myh66.com>

<http://usermanuals.us>

<http://www.somanuals.com>

<http://www.4manuals.cc>

<http://www.manual-lib.com>

<http://www.404manual.com>

<http://www.luxmanual.com>

<http://aubethermostatmanual.com>

Golf course search by state

<http://golfingnear.com>

Email search by domain

<http://emailbydomain.com>

Auto manuals search

<http://auto.somanuals.com>

TV manuals search

<http://tv.somanuals.com>