

Owner's Manual

**CRAFTSMAN**<sup>®</sup>

# 10 TON HYDRAULIC LOG SPLITTER

Model No. 486.24540

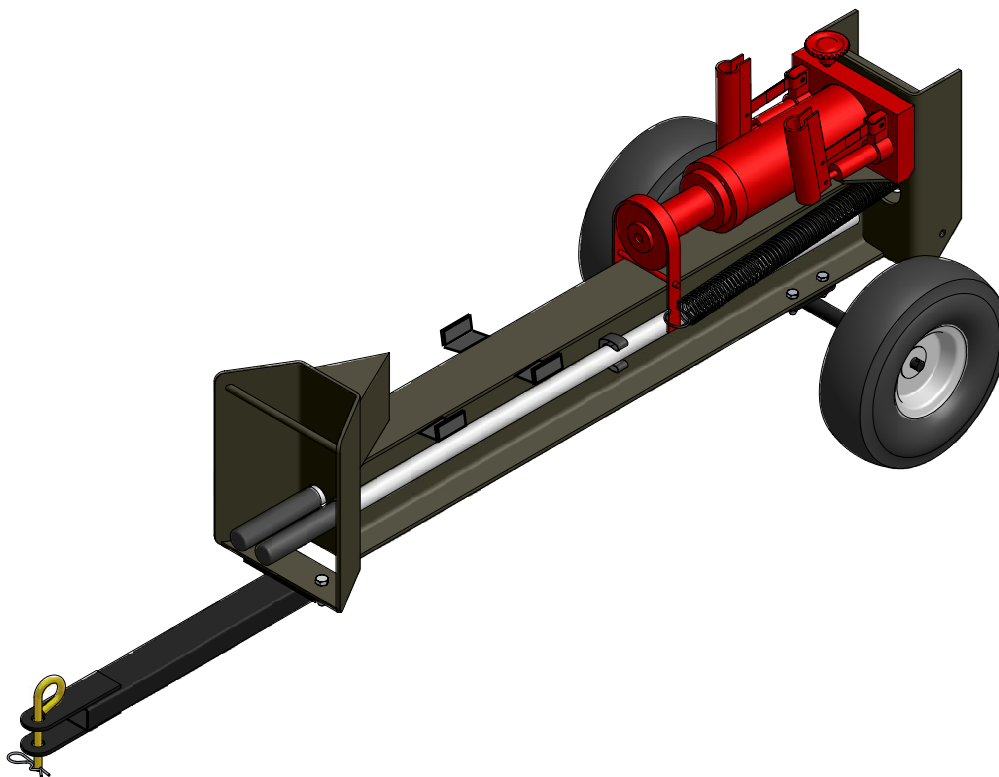

## CAUTION:

Before using this product,  
read this manual and follow  
all Safety Rules and  
Operating Instructions.

## IMPORTANT - READ THIS FIRST!!!

For Missing Parts or Assembly Questions

Please Call 1-866-576-8388

Mon.-Fri. 7am - 5pm CST.

FAX 217-728-2032 or email [info@agri-fab.com](mailto:info@agri-fab.com)

Missing parts will be sent UPS in 24 hours directly to your home.

- **Safety**
- **Assembly**
- **Operation**
- **Maintenance**
- **Parts**

Sears, Roebuck and Co., Hoffman Estates, IL 60179 U.S.A.  
[www.sears.com/craftsman](http://www.sears.com/craftsman)

FORM NO. 49668 (11/1/05)

## TABLE OF CONTENTS

SAFETY RULES	2	OPERATION	6
CARTON CONTENTS	3	MAINTENANCE	6
FULL SIZE HARDWARE CHART	4	REPAIR PARTS LIST	7
ASSEMBLY	5	PARTS ORDERING/SERVICE	8

## WARRANTY

### LIMITED ONE YEAR WARRANTY ON CRAFTSMAN HYDRAULIC LOG SPLITTER

For one year from the date of purchase, when this log splitter is maintained and lubricated according to the operating and maintenance instructions in the owner's manual, Sears will repair any defect in material or workmanship free of charge. If this log splitter is used for commercial or rental purposes, this warranty applies for only 90 days from the date of purchase.

This warranty does not cover repairs necessary because of operator negligence or abuse, including the failure to maintain the equipment according to instructions contained in the owner's manual.

WARRANTY SERVICE IS AVAILABLE BY CONTACTING THE NEAREST SEARS SERVICE CENTER/DEPARTMENT IN THE UNITED STATES.

This warranty applies only while product is in the United States.

This warranty gives you the specific legal rights, and you may also have other rights which vary from state to state.

Sears, Roebuck and Co. D/817 WA. Hoffman Estates, Chicago, IL 60179

## SAFETY RULES

**WARNING:** When using hydraulic equipment, basic safety precautions should always be followed to reduce the risk of personal injury and hazards due to over pressurization. **READ ALL INSTRUCTIONS BEFORE USING THIS TOOL!**

1. **KEEP WORK AREA CLEAN.** Cluttered areas invite injuries.
2. **OBSERVE WORK AREA CONDITIONS.** Do not use tools in damp, wet, or poorly lit locations. Don't expose to rain. Keep work area well lit.
3. **KEEP CHILDREN AWAY.** Children must never be allowed in the work area.
4. **STORE IDLE EQUIPMENT.** When not in use, log splitter should be stored in a dry location to inhibit rust.
5. **DO NOT FORCE THE TOOL.** It will do the job better and more safely at the rate for which it was intended. Do not use inappropriate attachments in an attempt to exceed the tool's capacities.
6. **USE THE RIGHT TOOL FOR THE JOB.** Do not attempt to force a small tool or attachment to do the work of a larger industrial tool. Do not use a tool for a purpose for which it was not intended.
7. **DRESS PROPERLY.** Do not wear loose clothing or jewelry as they can be caught in moving parts.
8. **USE EYE AND EAR PROTECTION.** Wear ANSI approved goggles when operating log splitter.
9. **DO NOT OVERREACH.** Keep proper footing and balance at all times. Do not reach over or across running machines.
10. **MAINTAIN TOOLS WITH CARE.** Keep tools sharp and clean for better and safer performance. The handles must be kept clean, dry, and free from oil and grease at all times.
11. **Keep hands, face and body away from log when it is being split.**

12. **STAY ALERT.** Watch what you are doing, use common sense. Do not operate any tool when you are tired.
13. **CHECK DAMAGED PARTS.** Before using any tool, any part that appears damaged should be carefully checked to determine that it will operate properly and perform its intended function. Check for alignment and binding of moving parts; any broken parts or mounting fixtures; and any other condition that may affect proper operation. Any part that is damaged should be properly repaired or replaced by a qualified technician.
14. **REPLACEMENT PARTS AND ACCESSORIES.** When servicing, use only identical replacement parts. Use of any other parts will void the warranty. Only use accessories intended for use with this tool.
15. **DO NOT OPERATE TOOL IF UNDER THE INFLUENCE OF ALCOHOL OR DRUGS.** Read warning labels on prescriptions to determine if your judgment or reflexes are impaired while taking drugs. If there is any doubt, do not operate the tool.
16. Do Not exceed maximum tire pressure found on side wall of tire.

## CARTON CONTENTS

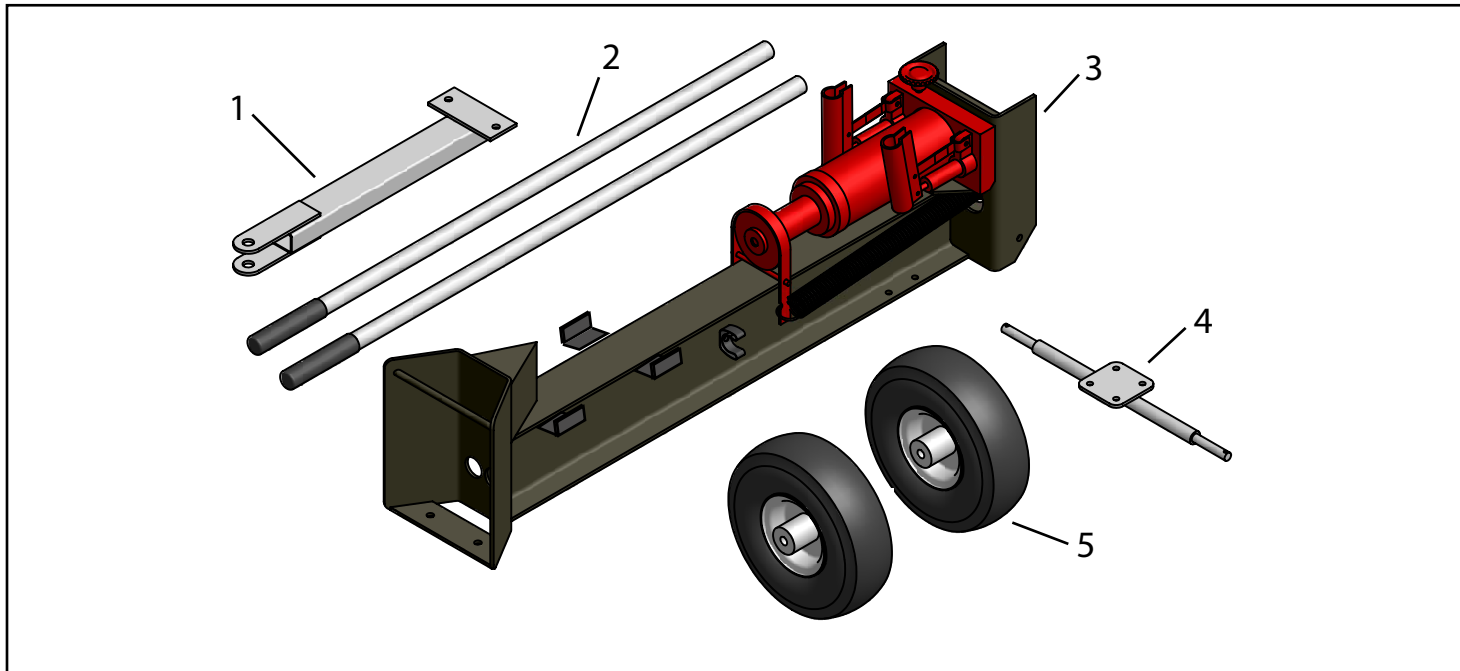

#	PART #	DESCRIPTION	QTY
1	65238	HITCH ASSY	1
2	65240	HANDLE ASSY	2
3	65237	LOG SPLITTER	1
4	65239	AXLE ASSY	1
5	46503	WHEEL	2

# PARTS PACKAGE

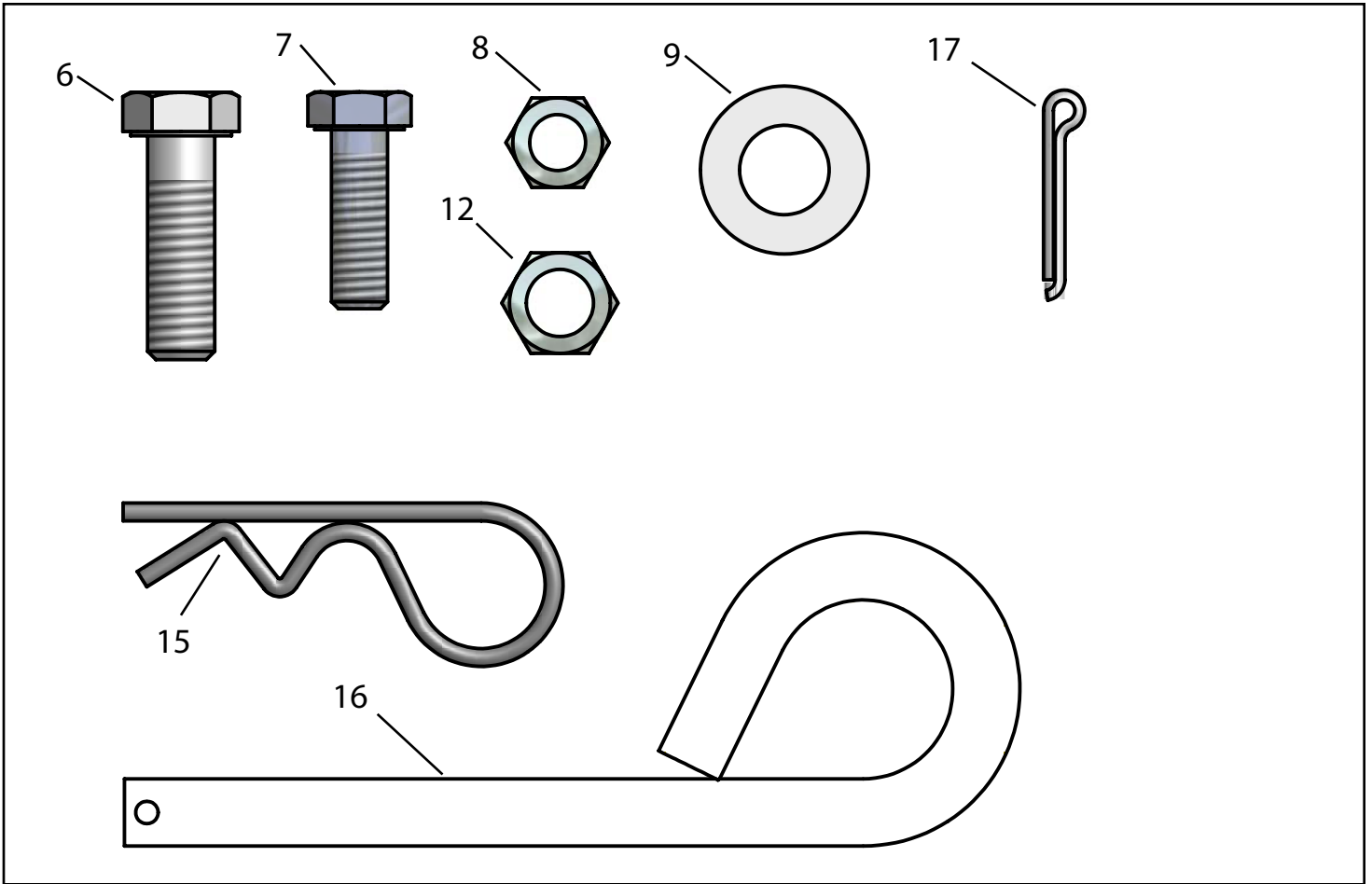

#	PART #	DESCRIPTION	QTY
6	49659	BOLT, HEX M10 x 25	2
7	49664	BOLT, HEX M8 x 25	4
8	49667	NUT, NYLOCK M8	4
9	R19171616	WASHER, FLAT 1/2	2

#	PART #	DESCRIPTION	QTY
12	47810M	NUT, NYLOCK M10	2
15	43343	COTTER, HAIRPIN	1
16	23353	PIN, HITCH	1
17	43010	COTTER, PIN	2

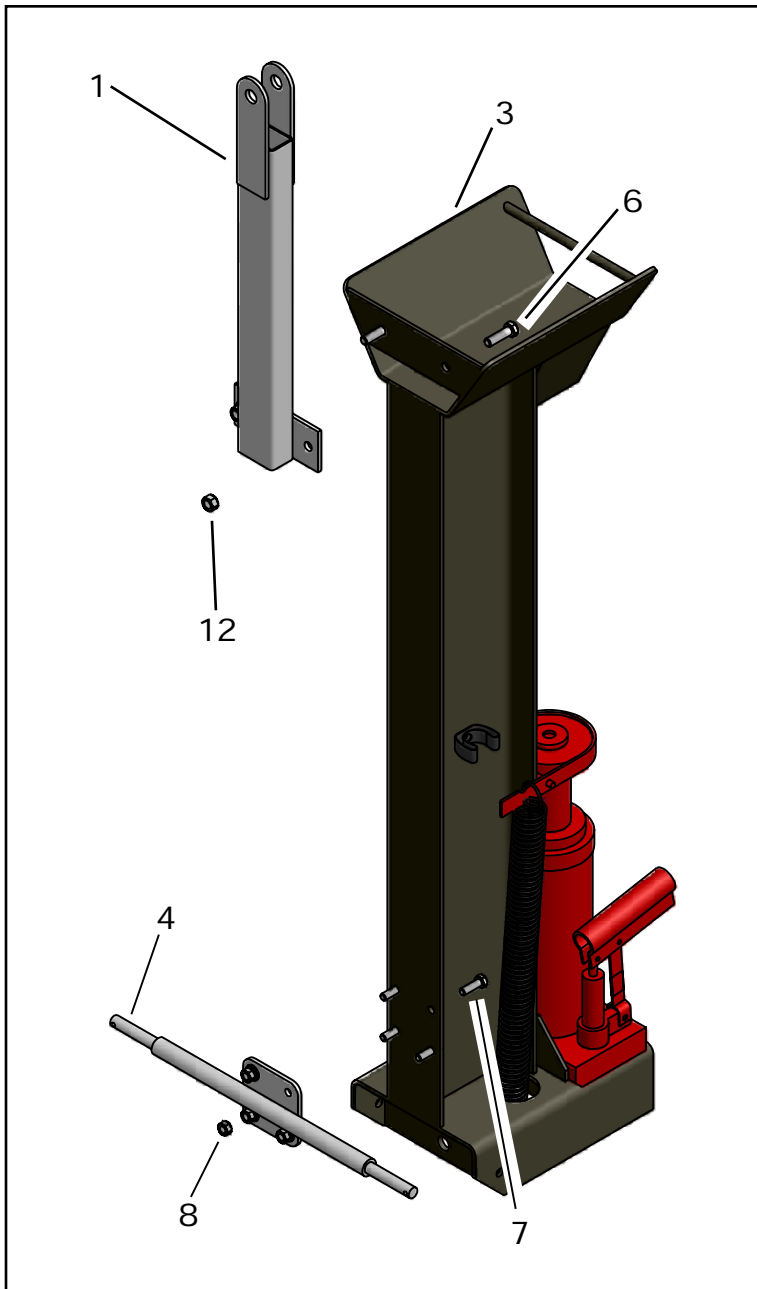

Figure 1

## ASSEMBLY INSTRUCTIONS

### Tools Needed:

- (2) 17mm Open End Wrench
- (1) 14mm Open End Wrench
- (1) 13mm Open End Wrench
- (1) Pliers

1. Verify that all parts and all fasteners (Shown full size) on page 4 are included in the carton and parts bag. Refer to page 4 to identify fasteners used in the following instructions.
2. With the Log Splitter(3) standing on end, attach the Hitch Assy(1) using two M10 x 25 Hex Bolts(6), and secure with two M10 Hex Nuts(12). Be sure that all bolts are tight. (Figure 1)

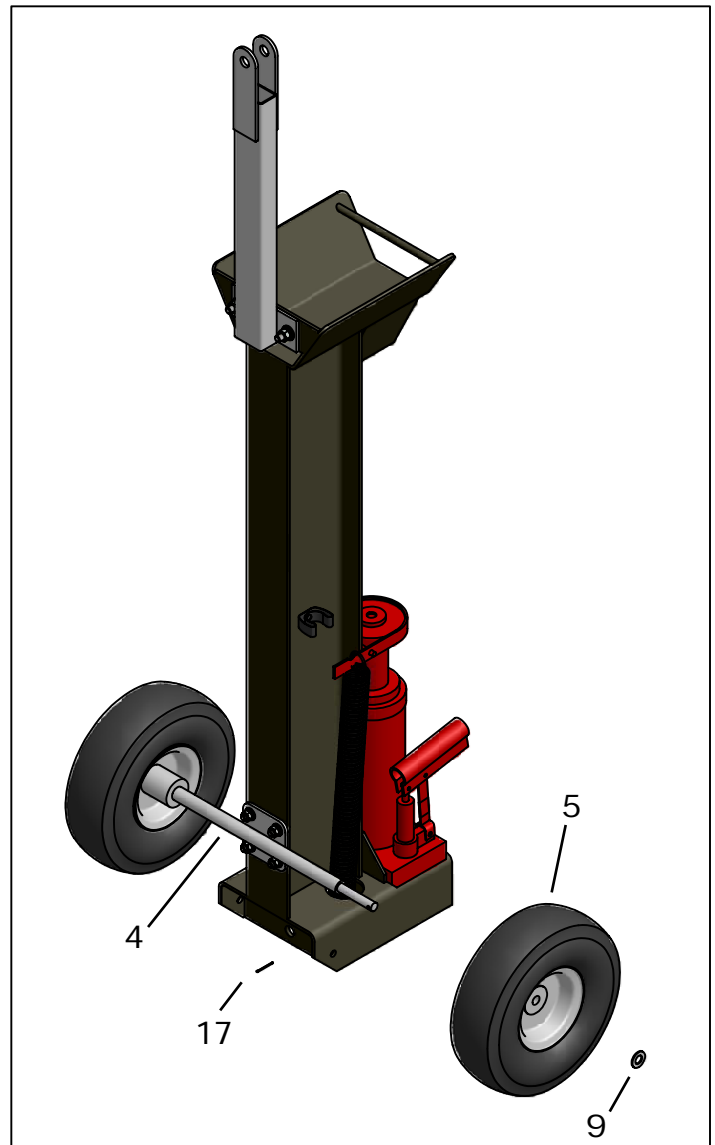

Figure 2

3. Attach Axle Assy(4) to the Log Splitter(3) using four M8 x 25 Hex Bolts(7), and secure with four M8 Hex Nuts(8). Be sure that all bolts are tight. (Figure 1)
4. Slide the Wheel(5) on to the Axle Assy(4) with the long hub facing inwards. Slide a 1/2 Flat Washer(9) onto the outside of the axle. Secure with Cotter Pin(17), bend the ends with a pair of pliers. (Repeat for other wheel) (Figure 2)
5. This Log Splitter will attach and tow behind any standard lawn and garden tractor. Use the supplied Hitch Pin, and Haircotter Pin to attach to tractor. In addition there is a hitch located on the rear of the unit, which allows you to tow a cart behind the Log Splitter.
6. As shown during assembly this unit will stand on its end for easy storage.

## OPERATION

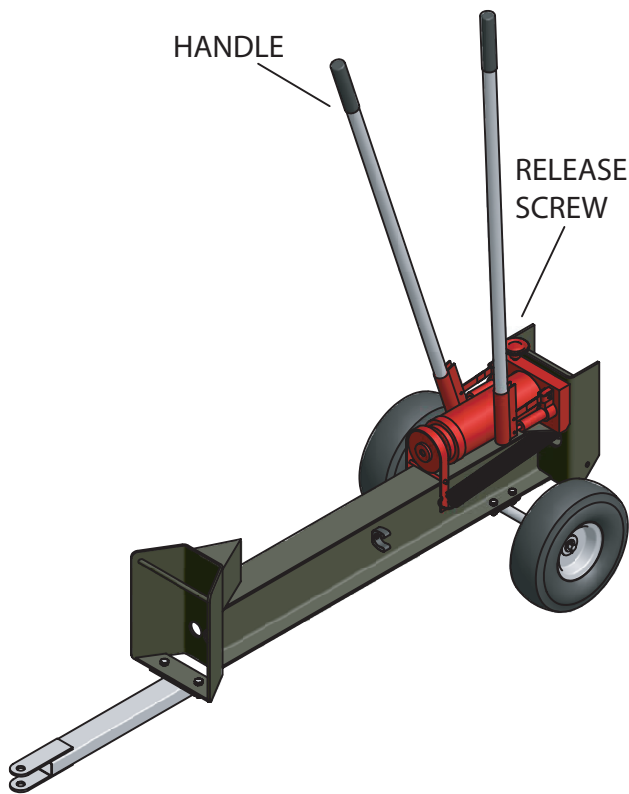

Figure 3

## MAINTENANCE

After every use, wipe down the Hydraulic Log Splitter to remove any tree sap or dirt left behind. This will extend the life of the tool.

### Bleeding The Log Splitter

1. Operate the log splitter to extend the Piston Rod to its maximum length.
2. Remove the Oil Filling Plug.
3. Turn the Release Screw counterclockwise as fast as possible, the Piston Rod will retract and push air from the cylinder out of the Oil Filling Plug.
4. Replace the Oil Filling Plug. Repeat steps 1-4 as necessary.

### Adding Oil



If you should need to add hydraulic oil to the Log Splitter, turn the release screw counterclockwise to retract the piston rod, remove the Oil Filling Plug, and add oil until the oil is 1/2" from top (when log splitter is laying down).

1. Gather the logs you wish to split. Make sure the maximum length of each log does not exceed 18". If the log does exceed that measurement, you must cut the log to fit the maximum length of the tool.
2. Make sure the Piston Rod is fully retracted into the cylinder. If necessary, turn the RELEASE SCREW counterclockwise to release the hydraulic pressure. Tighten the RELEASE SCREW.
3. Place the log between the Wedge and Piston Assembly. Rest the log in the metal bracket Cradle.
4. Wear eye protection (goggles) when operating the Hydraulic Log Splitter
5. It is recommended you operate the Log Splitter in the following manner. Stand behind the log splitter and grip one Handle in each hand and pump the Handles in a back-and-forth motion with one Handle fully forward and one fully rearward as shown in figure 3.
6. Repeat Step "5" to advance the Piston Rod forward. This will push the log against the Wedge and Split it.
7. When you have split the log, remove the split pieces.
8. Turn the RELEASE SCREW counterclockwise to draw the piston rod back into the cylinder. Tighten the RELEASE SCREW when the piston rod has retracted fully.
9. When you are done, it is recommended you store your Hydraulic Log Splitter with the RELEASE SCREW opened to relieve any hydraulic pressure during non-use.

## SPECIFICATIONS

Maximum Log Length:	18"
Ram Stroke:	8-1/16"
Cradle Dimensions:	3-3/4" x 4" x 4"
Base Dimensions:	42-1/8"L x 8-1/16"W x 37"H

## TROUBLE SHOOTING

1. If hydraulic cylinder does not move forward when pumping handles.
  - A. Check to see if Release Screw is tightened in the closed position.
  - B. Check to see if you need to add hydraulic oil.

# REPAIR PARTS FOR HYDRAULIC LOG SPLITTER - MODEL 486.24540

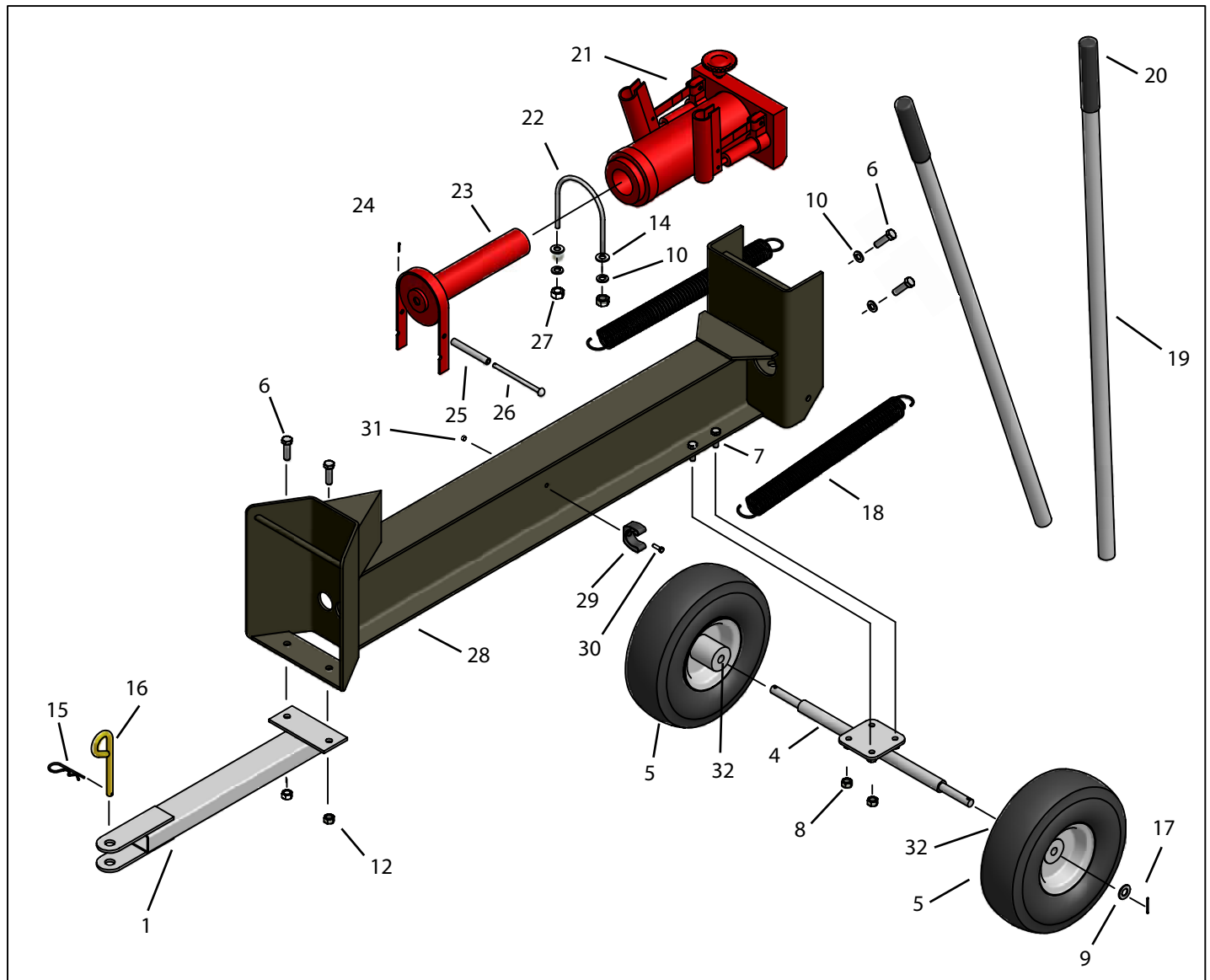

#	PART #	DESCRIPTION	QTY
1	65238	Hitch Assembly	1
4	65239	Axle Assembly	1
5	46503	Wheel	2
6	49659	Hex, Bolt M10 x 25	4
7	49664	Hex, Bolt M8 x 25	4
8	49667	Nut, Nylock M8	4
9	R19171616	Washer, Axle	2
10	43003	Washer, Lock 3/8"	4
12	47810M	Nut, Nylock M10	2
14	43070	Washer, Flat 3/8"	2
15	43343	Hairpin Cotter	1
16	23353	Hitch Pin	1
17	43010	Cotter Pin	2
18	49644	Spring	2

#	PART #	DESCRIPTION	QTY
19	49657	Operating Lever	2
20	49658	Grip	2
21	49642	Ram Assembly	1
22	49645	U-Clamp	1
23	49643	Jack Top Plate	1
24	44101	Cotter Pin, 3/32 x 3/4"	1
25	49647	Spacer	1
26	49648	Clevis Pin	1
27	49660	Hex, Hex M10	2
28	49641	Frame	1
29	47397	Handle Clamp	2
30	49650	Bolt, Hex M5 x 10	1
31	49651	Nut, Hex M5	1
32	49734	Bushing, Wheel	2

# Get it fixed, at your home or ours!

For repair of major brand appliances **in your own home...**  
no matter who made it, no matter who sold it!

**1-800-4-MY-HOME<sup>SM</sup>** Anytime, day or night  
(1-800-469-4663)

[www.sears.com](http://www.sears.com)

To bring in products such as vacuums, lawn equipment and electronics  
for repair, call for the location of your nearest **Sears Parts & Repair Center.**

**1-800-488-1222** Anytime, day or night

[www.sears.com](http://www.sears.com)

For the replacement parts, accessories and owner's manuals  
that you need to do-it-yourself, call **Sears PartsDirect<sup>SM</sup>!**

**1-800-366-PART** 6 a.m. – 11 p.m. CST,  
(1-800-366-7278) 7 days a week

[www.sears.com/partsdirect](http://www.sears.com/partsdirect)

To purchase or inquire about a Sears Service Agreement:

**1-800-827-6655**

7 a.m. – 5 p.m. CST, Mon. – Sat.

Para pedir servicio de reparación a domicilio,  
y para ordenar piezas con entrega a domicilio:

**1-888-SU-HOGAR<sup>SM</sup>**  
(1-888-784-6427)

Au Canada pour service en français:

**1-877-LE-FOYER<sup>SM</sup>**  
(1-877-533-6937)





## Free Manuals Download Website

<http://myh66.com>

<http://usermanuals.us>

<http://www.somanuals.com>

<http://www.4manuals.cc>

<http://www.manual-lib.com>

<http://www.404manual.com>

<http://www.luxmanual.com>

<http://aubethermostatmanual.com>

Golf course search by state

<http://golfingnear.com>

Email search by domain

<http://emailbydomain.com>

Auto manuals search

<http://auto.somanuals.com>

TV manuals search

<http://tv.somanuals.com>