

# **SEARS** OWNER'S MANUAL

**MODEL NO.  
536.885020**

**Caution:  
Read and Follow  
All Safety Rules  
and Instructions  
Before Operating  
This Equipment**

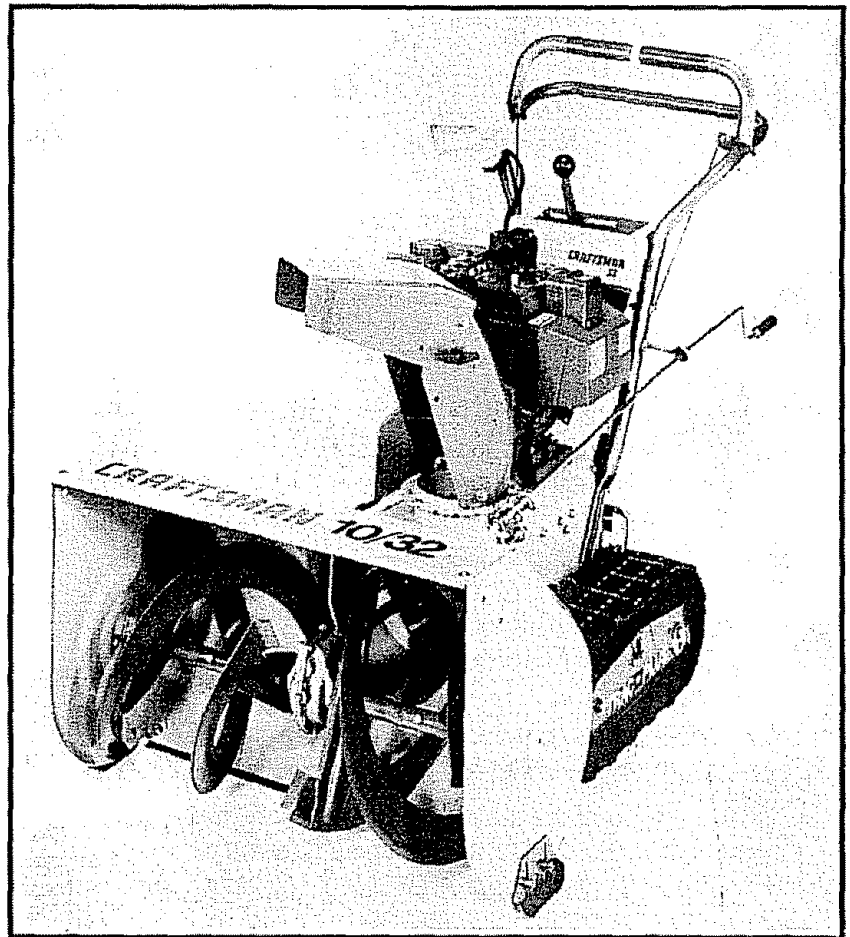

## **CRAFTSMAN®**

**10 HORSEPOWER  
32" DUAL STAGE  
TRAC-PLUS  
120V. ELECTRIC START  
SNOW THROWER**

- Assembly
- Operation
- Maintenance
- Service and Adjustments
- Repair Parts

---

**SEARS, ROEBUCK AND CO., Chicago, IL 60684 U.S.A.**

---

## SAFETY RULES



CAUTION: ALWAYS DISCONNECT SPARK PLUG WIRE AND PLACE WIRE WHERE IT CANNOT CONTACT SPARK PLUG TO PREVENT ACCIDENTAL STARTING WHEN SETTING-UP, TRANSPORTING, ADJUSTING OR MAKING REPAIRS.



### IMPORTANT

SAFETY STANDARDS REQUIRE OPERATOR PRESENCE CONTROLS TO MINIMIZE THE RISK OF INJURY. YOUR SNOW THROWER IS EQUIPPED WITH SUCH CONTROLS. DO NOT ATTEMPT TO DEFEAT THE FUNCTION OF THE OPERATOR PRESENCE CONTROL UNDER ANY CIRCUMSTANCES.

#### BEFORE USE

- Read the Owner's Manual carefully. Be thoroughly familiar with the controls and the proper use of the snow thrower. Know how to stop the snow thrower and disengage the controls quickly.
- Do not operate the snow thrower without wearing adequate winter outer garments. Wear footwear that will improve footing on slippery surfaces.
- Keep the area of operation clear of all persons, particularly small children, and pets.
- Thoroughly inspect the area where the snow thrower is to be used and remove all doormats, sleds, boards, wires, and other foreign objects.
- Use extension cords and receptacles as specified by the manufacturer for all snow throwers with electric drive motors or electric starting motors.
- Use only attachments and accessories approved by the manufacturer of the snow thrower (such as tire chains, electric start kits, etc.)
- Never operate the snow thrower without good visibility or light. Always be sure of your footing, and keep a firm hold on the handles. Walk; never run.
- This snow thrower is for use on sidewalks, driveways, and other ground level surfaces. CAUTION should be exercised while using on steep sloping surfaces. DO NOT USE SNOW THROWER ON SURFACES ABOVE GROUND LEVEL, such as roofs of residences, garages, porches or other such structures or buildings.
- Check shear bolts and other bolts at frequent intervals for proper tightness to be sure the snow thrower is in safe working condition.
- Disengage all clutches and shift into neutral before starting the engine.
- Adjust the snow thrower height to clear gravel or crushed rock surface.
- Let engine and snow thrower adjust to outdoor temperatures before starting to clear snow.

#### FUEL SAFETY

- Handle fuel with care; it is highly flammable.
- Use an approved fuel container.
- Check fuel supply before each use, allowing space for expansion as the heat of the engine and/or sun can cause fuel to expand.
- Fill fuel tank outdoors with extreme care. Never fill fuel tank indoors.
- Replace fuel tank cap securely and wipe up spilled fuel.
- Never remove fuel tank cap or add fuel to a running engine or hot engine.
- Never store fuel or snow thrower with fuel in the tank inside of a building where fumes may reach an open flame or spark.

#### OPERATING SAFETY

- Never allow children or young teenagers to operate the snow thrower and keep them away while it is operating. Never allow adults to operate the snow thrower without proper instruction. Do not carry passengers.
- Always wear safety glasses or eye shields during operation or while performing an adjustment or repair to protect eyes from foreign objects that may be thrown from the snow thrower.
- Exercise extreme caution when operating on or crossing gravel drives, walks, or roads. Stay alert for hidden hazards or traffic.
- Do not put hands or feet near or under rotating parts. Keep clear of the discharge opening at all times.
- Exercise caution to avoid slipping or falling, especially when operating in reverse.
- Do not clear snow across the face of slopes. Exercise caution when changing direction on slopes. Do not attempt to clear steep slopes.
- Never operate the snow thrower without proper guards, plates or other safety protective devices in place.

## SAFETY RULES

- Never operate the snow thrower near glass enclosures, automobiles, window wells, drop-offs, and the like without proper adjustment of the snow discharge angle. Keep children and pets away.
- Never operate the snow thrower at high transport speeds on slippery surfaces. Look behind and use care when backing.
- Never direct discharge at bystanders or allow anyone in front of the snow thrower.
- Do not run the engine indoors, except when starting the engine and for transporting the snow thrower in or out of the building. Open the outside doors; exhaust fumes are dangerous (containing CARBON MONOXIDE, an ODORLESS and DEADLY GAS).
- Take all possible precautions when leaving the snow thrower unattended. Disengage the auger/impeller, shift to neutral, stop engine, and remove key.
- Do not overload the machine capacity by attempting to clear snow at too fast a rate.

### SAFE STORAGE

- Always refer to Owner's Manual instructions for important details if the snow thrower is to be stored for an extended period.
- Disengage power to the auger/impeller when snow thrower is transported or not in use.
- Never store the snow thrower with fuel in the fuel tank inside a building where ignition sources are present such as hot water and space heaters, clothes dryers, and the like. Allow the engine to cool before storing in any enclosure.

### REPAIR/ADJUSTMENTS SAFETY

- After striking a foreign object, stop the engine (motor), remove the wire from the spark plug, disconnect the cord on electric motors, thoroughly inspect the snow thrower for any damage, and repair the damage before restarting and operating the snow thrower.
- If the snow thrower should start to vibrate abnormally, stop the engine (motor) and check immediately for the cause. Vibration is generally a warning of trouble.
- Stop the engine (motor) whenever you leave the operating position, before unclogging the auger/impeller housing or discharge guide, and when making any repairs, adjustments, or inspections.
- When cleaning, repairing, or inspecting, make certain the auger/impeller and all moving parts have stopped. Disconnect the spark plug wire and keep the wire away from the plug to prevent accidental starting.
- Never attempt to make any adjustments while the engine is running (except when specifically recommended by manufacturer).
- Maintain or replace safety and instruction labels, as necessary.
- Run the snow thrower a few minutes after throwing snow to prevent freeze-up of the auger/impeller.

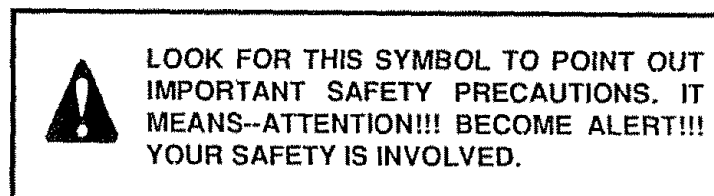
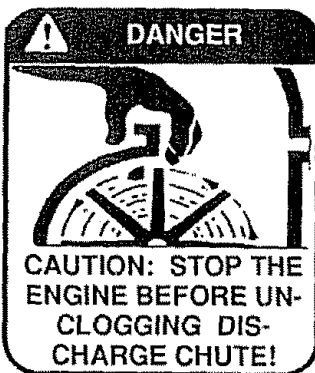

**CONGRATULATIONS** on your purchase of a Sears Craftsman Snow Thrower. It has been designed, engineered and manufactured to give you the best possible dependability and performance.

Should you experience any problem you cannot easily remedy, please contact your nearest Sears Service Center/Department. We have competent, well-trained technicians and the proper tools to service or repair this unit.

Please read and retain this manual. The instructions will enable you to assemble and maintain your snow thrower properly. Always observe the "SAFETY RULES."

MODEL  
NUMBER 536.885020

SERIAL  
NUMBER \_\_\_\_\_

DATE OF  
PURCHASE \_\_\_\_\_

THE MODEL AND SERIAL NUMBERS WILL BE FOUND ON A DECAL ATTACHED TO THE REAR OF THE SNOW THROWER HOUSING.

YOU SHOULD RECORD BOTH SERIAL NUMBER AND DATE OF PURCHASE AND KEEP IN A SAFE PLACE FOR FUTURE REFERENCE.

## PRODUCT SPECIFICATIONS

<b>HORSE POWER:</b>	10 hp
<b>DISPLACEMENT:</b>	21.82 cu. in.
<b>GASOLINE CAPACITY:</b>	4 quarts Unleaded
<b>OIL (26 oz. Capacity):</b>	10W-30 (5W - 30) *
<b>SPARK PLUG :</b> (GAP .030 in.)	Champion J8C
<b>VALVE CLEARANCE:</b>	Intake: .010 In. Exhaust: .010 In.

\* S.A.E. 5W-30 motor oil may be used to make starting easier in areas where temperature is consistently 20° F. or lower.

## MAINTENANCE AGREEMENT

A Sears Maintenance Agreement is available on this product. Contact your nearest Sears Store for details.

## CUSTOMER RESPONSIBILITIES

- Read and observe the safety rules.
- Follow a regular schedule in maintaining, caring for and using your snow thrower.
- Follow the instructions under "Maintenance" and "Storage" sections of this owner's manual.

## TWO YEAR LIMITED WARRANTY ON CRAFTSMAN SNOW THROWER

For two years from the date of purchase, when this Craftsman Snow Thrower is maintained, lubricated and tuned-up according to the instructions in the owner's manual, Sears will repair, free of charge, any defect in material and workmanship.

If this Craftsman Snow Thrower is used for commercial or rental purposes, this warranty applies for only 90 days from the date of purchase.

This warranty does not cover the following:

- Expendable items which become worn during normal use, such as spark plugs, tire chains, drive belts and shear pins.
- Repairs necessary because of operator abuse or negligence, including bent crankshafts and the failure to maintain the equipment according to the instructions contained in the owner's manual.

WARRANTY SERVICE IS AVAILABLE BY RETURNING THE CRAFTSMAN SNOW THROWER TO THE NEAREST SEARS SERVICE CENTER/DEPARTMENT IN THE UNITED STATES. THIS WARRANTY APPLIES ONLY WHILE THIS PRODUCT IS IN USE IN THE UNITED STATES.

This warranty gives you specific legal rights, and you may also have other rights which may vary from state to state.

SEARS, ROEBUCK AND CO. Department 731CR-W Sears Tower, Chicago, IL 60684

## TABLE OF CONTENTS

SAFETY RULES .....	2,3	MAINTENANCE .....	17,18
PRODUCT SPECIFICATIONS .....	4	SERVICE AND ADJUSTMENTS .....	19-25
CUSTOMER RESPONSIBILITIES .....	4	STORAGE .....	26
WARRANTY .....	4	SERVICE RECOMMENDATIONS .....	27
TABLE OF CONTENTS .....	5	TROUBLE SHOOTING .....	28
INDEX .....	5	REPAIR PARTS (SNOW THROWER) .....	30-38
ASSEMBLY .....	6-10	REPAIR PARTS (ENGINE) .....	39-42
OPERATION .....	11-16	PARTS ORDERING/SERVICE .....	Back Cover

## INDEX

<p style="text-align: center;"><b>A</b></p> <p>Adjustment:</p> <ul style="list-style-type: none"> <li>Auger ..... 20</li> <li>Belt ..... 20</li> <li>Belt Guide ..... 22</li> <li>Cable ..... 20</li> <li>Carburetor ..... 25</li> <li>Friction Wheel ..... 22</li> <li>Spark Plug ..... 25</li> <li>Track ..... 24</li> <li>Traction and Auger ..... 20</li> </ul> <p>Assembly:</p> <ul style="list-style-type: none"> <li>Crank Assembly ..... 8</li> <li>Headlight ..... 9</li> <li>Shifter Lever ..... 9, 19</li> <li>Skid Height Adjustment ..... 19</li> <li>Unpacking ..... 7</li> </ul> <p style="text-align: center;"><b>B</b></p> <p>Belts:</p> <ul style="list-style-type: none"> <li>Adjust Belts ..... 20</li> <li>Belt Guide Adjustment ..... 22</li> <li>Belt Maintenance ..... 17</li> <li>Replace Belts ..... 21, 22</li> </ul> <p style="text-align: center;"><b>C</b></p> <p>Cables, Clutch ..... 7, 9, 12</p> <p>Carburetor: ..... 25, 26</p> <ul style="list-style-type: none"> <li>Chain ..... 17</li> <li>Choke ..... 11, 12, 14, 15</li> <li>Clutch, Levers ..... 11, 12</li> </ul> <p>Controls:</p> <ul style="list-style-type: none"> <li>Engine ..... 11, 12, 14</li> <li>Snow Thrower ..... 11</li> </ul> <p>Crank:</p> <ul style="list-style-type: none"> <li>Adjusting Rod ..... 19</li> <li>Assembly ..... 8</li> <li>Operation ..... 12</li> </ul> <p>Customer Responsibilities ..... 4</p> <p style="text-align: center;"><b>D</b></p> <ul style="list-style-type: none"> <li>Drive, Auger ..... 12, 21</li> <li>Drive, Traction ..... 12, 20</li> <li>Deflector, Snow Chute ..... 11, 12</li> </ul> <p style="text-align: center;"><b>E</b></p> <p>Engine:</p> <ul style="list-style-type: none"> <li>Control ..... 11, 12, 14, 15</li> <li>Oil Cap ..... 4, 13, 18</li> <li>Oil Change ..... 18</li> <li>Oil Level ..... 13, 18</li> <li>Oil Type ..... 4, 13, 18</li> <li>Speed Governor ..... 26</li> <li>Starting, Electrically ..... 14</li> <li>Starting, Manually ..... 15</li> <li>Storage ..... 26</li> </ul>	<p style="text-align: center;"><b>F</b></p> <ul style="list-style-type: none"> <li>Fuel, Type ..... 4, 13</li> <li>Fuel, Storage ..... 13, 26</li> </ul> <p>Friction Wheel:</p> <ul style="list-style-type: none"> <li>Adjustment ..... 22</li> <li>Replacement ..... 23</li> </ul> <p style="text-align: center;"><b>G</b></p> <p>Gears:</p> <ul style="list-style-type: none"> <li>Auger Gear Box ..... 17-18</li> <li>Hex Shaft ..... 17</li> </ul> <p style="text-align: center;"><b>H</b></p> <ul style="list-style-type: none"> <li>Handle, Upper and Lower ..... 7</li> <li>Headlight ..... 9, 11</li> <li>Height Adjust Skids ..... 7, 19</li> <li>Hex Shaft ..... 17</li> </ul> <p style="text-align: center;"><b>I</b></p> <ul style="list-style-type: none"> <li>Ignition, Key ..... 11, 12, 14, 15</li> <li>Index ..... 5</li> </ul> <p style="text-align: center;"><b>L</b></p> <p>Levers:</p> <ul style="list-style-type: none"> <li>Auger Drive Clutch ..... 7, 11, 12, 20</li> <li>Choke ..... 11, 12, 14, 15</li> <li>Shifter ..... 10-12</li> <li>Throttle Control ..... 11, 12, 14, 15</li> <li>Traction Drive Clutch ..... 7, 11, 12, 20</li> </ul> <p>Lubrication:</p> <ul style="list-style-type: none"> <li>Auger Gear Box ..... 17, 18</li> <li>Auger Shaft ..... 17, 27</li> <li>Chain and Sprockets ..... 17, 27</li> <li>Engine ..... 4, 13, 18</li> <li>Hex Shaft and Gears ..... 17</li> <li>Weight Transfer System ..... 13, 17, 18</li> </ul> <p style="text-align: center;"><b>M</b></p> <p>Maintenance:</p> <ul style="list-style-type: none"> <li>Agreement ..... 4</li> <li>Auger Gear Box ..... 17, 18</li> <li>Auger Shaft ..... 17</li> <li>Chain and sprockets ..... 17</li> <li>Engine ..... 18</li> <li>General Recommendations ..... 17</li> <li>Hex Shaft and Gears ..... 17</li> <li>Weight Transfer System ..... 13, 19</li> </ul> <p style="text-align: center;"><b>O</b></p> <p>Oil:</p> <ul style="list-style-type: none"> <li>Engine ..... 4, 13, 18</li> <li>Extreme Cold Weather ..... 14, 15</li> <li>Storage ..... 13, 26</li> <li>Type ..... 4, 13, 18</li> </ul>	<p>Operation:</p> <ul style="list-style-type: none"> <li>Engine Controls ..... 11, 12, 14, 15</li> <li>Operating Snow Thrower ..... 11-16</li> <li>Operating Tips ..... 16</li> <li>Starting the Engine, Electric ..... 14</li> <li>Starting the Engine, Recoil ..... 15</li> <li>Snow Thrower Controls ..... 11, 12, 13</li> <li>Weight Transfer System ..... 13, 17, 19</li> </ul> <p style="text-align: center;"><b>P</b></p> <ul style="list-style-type: none"> <li>Parts ..... 30-42</li> <li>Primer Button ..... 11, 14, 15</li> </ul> <p style="text-align: center;"><b>R</b></p> <ul style="list-style-type: none"> <li>Repair/Replacement Parts ..... 30-42</li> <li>Recoil Starter ..... 15</li> </ul> <p>Replacements:</p> <ul style="list-style-type: none"> <li>Auger Shear Bolt ..... 24</li> <li>Belts ..... 20</li> <li>Friction Wheel ..... 22, 23</li> </ul> <p style="text-align: center;"><b>S</b></p> <ul style="list-style-type: none"> <li>Safety Rules ..... 2, 3</li> </ul> <p>Service and Adjustments:</p> <ul style="list-style-type: none"> <li>Auger Housing Height ..... 7, 19</li> <li>Auger Shear Bolt ..... 24</li> <li>Belts ..... 20</li> <li>Belt Guide ..... 22</li> <li>Belt Replacements ..... 21, 22</li> <li>Cable ..... 7, 10, 20</li> <li>Carburetor ..... 25, 26</li> <li>Friction Wheel ..... 22, 23</li> <li>Spark Plug ..... 25</li> <li>Track ..... 24</li> </ul> <p>Service Recommendations ..... 27</p> <ul style="list-style-type: none"> <li>Spark Plug ..... 18, 25</li> </ul> <p>Specifications ..... 4</p> <p>Speed Governor ..... 25</p> <p>Starting the Engine:</p> <ul style="list-style-type: none"> <li>Electric Start ..... 14</li> <li>Recoil Start ..... 15</li> </ul> <p>Stopping the Snow Thrower ..... 12</p> <ul style="list-style-type: none"> <li>Shipping Carton ..... 6, 7</li> <li>Skid Height ..... 7, 19</li> <li>Shifter Lever ..... 9, 11, 12</li> <li>Shear Bolts ..... 17, 24</li> </ul> <p>Storage ..... 26</p> <p style="text-align: center;"><b>T</b></p> <ul style="list-style-type: none"> <li>Table of Contents ..... 5</li> <li>Trouble Shooting Chart ..... 28</li> <li>Tools for Assembly ..... 6</li> <li>Traction Drive Belt ..... 20, 21, 22</li> <li>Track Adjustment ..... 6, 17, 24</li> </ul> <p style="text-align: center;"><b>W</b></p> <ul style="list-style-type: none"> <li>Warranty ..... 4</li> <li>Weight Transfer System ..... 13, 17, 19</li> </ul>
--	---	---

# ASSEMBLY

## THIS SNOW THROWER IS EQUIPPED WITH "TRAC-PLUS" AND ONLY MOVES EFFECTIVELY WHEN ENGINE IS RUNNING

If your snow thrower must be moved without the aid of the engine, it will be easier to pull the snow thrower backward by the handles, rather than pushing.

On start up, the track drive system may be tight and will loosen up as the snow thrower is used. After first use, check the track for tension and adjust if necessary. See the Track Adjustment paragraph in the Service and Adjustments section of this manual. Check track adjustment and fasteners regularly.

### CONTENTS OF SHIPPING CARTON

- 1 - Snow thrower completely assembled except for the crank assembly, shifter lever knob, the upper handle, and the chute deflector assembly.
- 1 - Parts Bag Containing:
  - 1 - Owner's Manual (Not Shown)
  - 1 - Electric Starter Cord 9.5 Ft. (Not Shown)

### TOOLS REQUIRED FOR ASSEMBLY

- 1 - Knife (to cut carton and plastic ties)
- 2 - 1/2 inch Wrenches (or adjustable wrenches)
- 2 - 9/16 inch Wrenches (or adjustable wrenches)
- 2 - 3/4 inch Wrenches (or adjustable wrenches)
- 1 - Pair Pliers or Screwdriver (to spread cotter pin)

### CONTENTS OF PARTS BAG

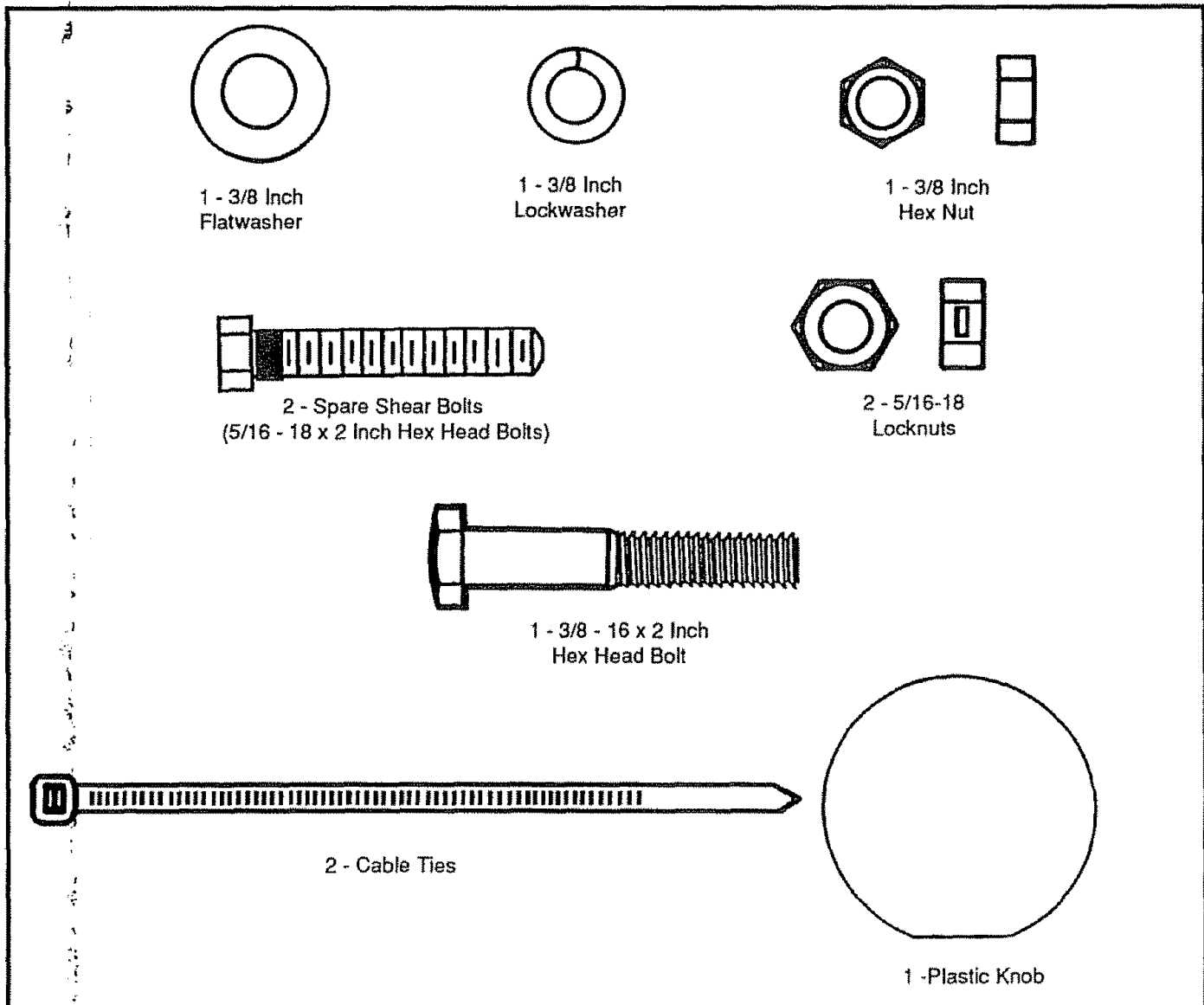

# ASSEMBLY

Figure 1 shows the snow thrower in the shipping position. Figure 2 shows the snow thrower completely assembled. Reference to the right and left hand side of the snow thrower is from the operator's position at the handle.

## TO REMOVE SNOW THROWER FROM CARTON (See Fig 1)

- Cut all four corners of the carton from top to bottom and lay the panels flat.
- Cut the cable ties attached to the augers.
- Cut and discard the ties that secure the crank assembly and place the assembly aside.
- Remove the packing material from the control panel.
- Cut and discard the packing securing the clutch cables to the lower handle.
- With two 9/16 inch wrenches, loosen (do not remove) both bolts securing the upper and lower handles. Swing the upper handle into the operating position.

**NOTE:** If the cables have become disconnected from the clutch levers, reinstall the cables as shown in Figure 3.

- Tighten both bolts securely.
- Roll the snow thrower off the skid by pulling on the handle.

**NOTE:** This snow thrower is equipped with a track drive and can be hard to push when the engine is not running. It is easier to pull the snow thrower backward if it must be moved without the engine running.

The drive system may be tight when you first use your snow thrower. It loosens up as you use it.

## HOW TO SET UP YOUR SNOW THROWER

### TO SET THE SKID HEIGHT

For shipping, the height adjust skids are reversed. To use your snow thrower, you need to remove the height adjust skids and reinstall as shown in Fig. 2. Then adjust the height adjust skids for surface conditions as follows:

- Loosen the mounting nuts on the skids (See Fig. 2).
- Place the extra shear bolts (in the parts bag) under each end of the scraper bar near but not under the skids.
- Push each skid up or down until it touches the ground and the scraper bar is resting on each shear bolt. Be sure the skids are set at the same height on both sides.
- Tighten the mounting nuts.

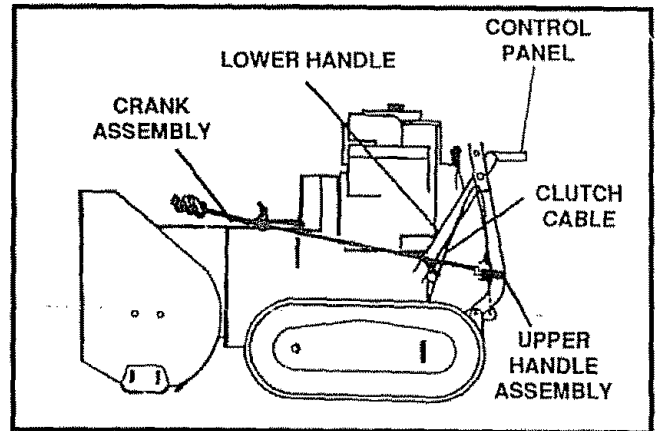

FIG. 1

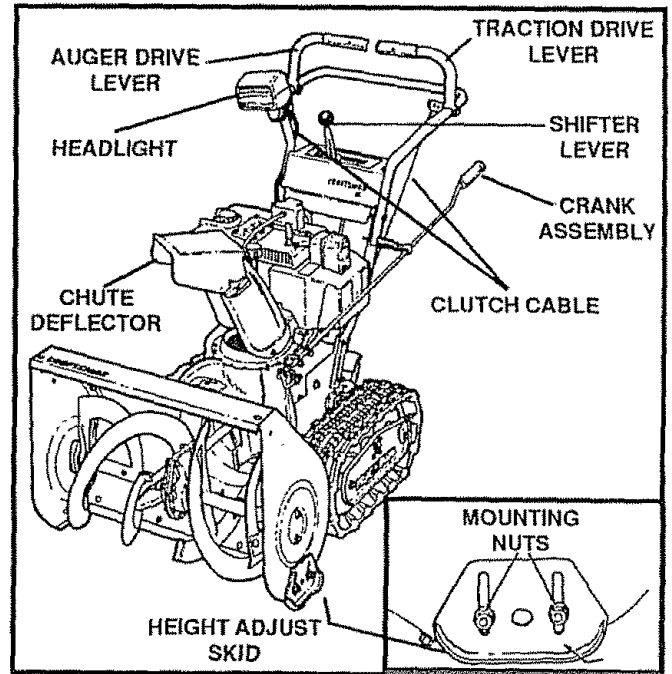

FIG. 2

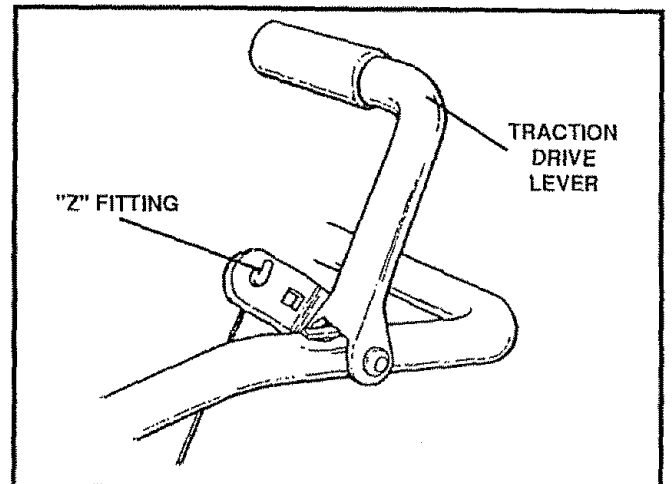

FIG. 3

# ASSEMBLY



**CAUTION: IF YOU ARE REMOVING SNOW FROM ANY ROCKY OR UNEVEN SURFACES, RAISE THE FRONT OF THE SNOW THROWER BY MOVING THE SKIDS DOWN. THIS WILL HELP TO PREVENT ROCKS AND OTHER DEBRIS FROM BEING PICKED UP AND THROWN BY THE AUGER.**

## TO INSTALL UPPER HANDLE AND CRANK ASSEMBLY

- On the right side of the handle, install and secure the following parts (found in parts bag) in the lower handle hole as shown in figure 4A:
  - 1 - 3/8" x 2" bolt
  - 1 - 3/8" flatwasher & 3/8" lockwasher
  - 1 - 3/8" nut
- Remove the 3/8" nylon locknut and flatwasher from the eye bolt assembly (on the chute crank assembly) and adjust the two remaining 3/8" jam nuts, the flatwasher and the adapter on the eye bolt about half way up the thread.
- Install eye bolt through the lower hole on the left hand side of the handle.
- Install the 3/8" flatwasher and 3/8" nylon locknut loosely on the eye bolt, as shown.
- Remove the plastic cap, the cotter pin and the flatwasher from the wormed end of the crank assembly and set aside (See Fig. 5).
- Rotate the notched section of the discharge chute toward the crank-adjusting rod.
- Install the wormed end of the crank through the hole in the adjusting rod and secure the end with the flat washer and cotter pin, as shown in Figure 5.
- Bend the ends of the cotter pin around the rod and re-install the plastic cap.
- Tighten the eye bolt installed earlier. Keep the eye in line with the rod while tightening the inside nut securely.
- Tighten the outside 3/8" jam nut up against the other 3/8" jam nut (See Fig. 4B).
- Rotate the chute crank fully clockwise and fully counter-clockwise. The discharge chute should rotate fully to the outer diameter of the worm and should clear approximately 1/8" (See Fig 5). If the chute crank needs to be adjusted, go to the Service and Adjustments section on page 18.

**NOTE:** Be sure the crank does not touch the side of the engine or the cover will be scratched.

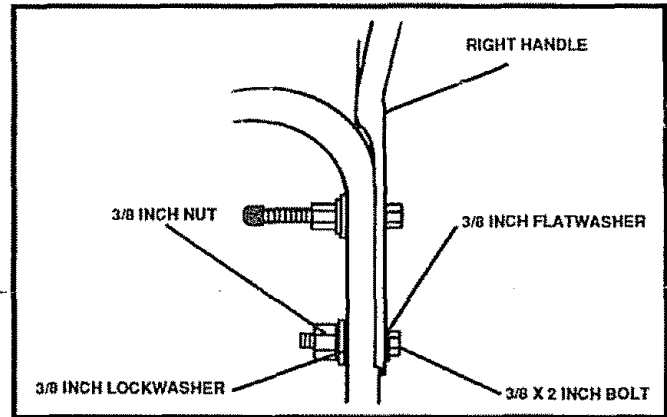

FIG. 4A

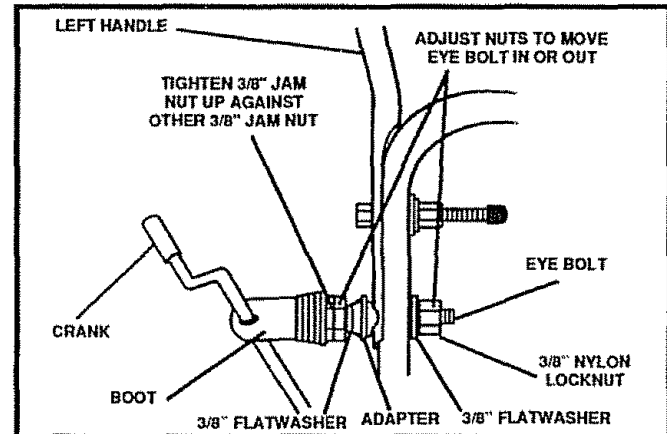

FIG. 4B

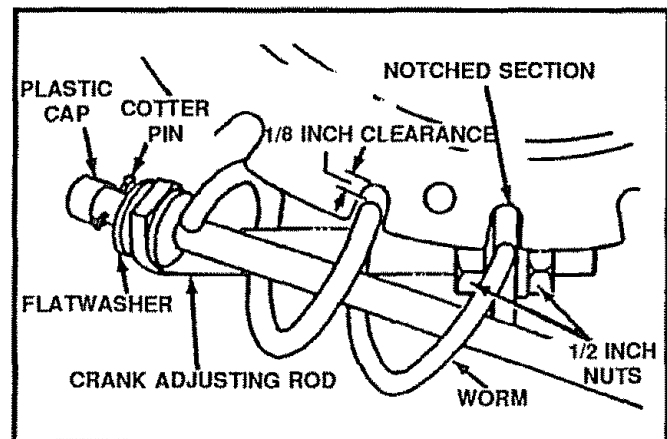

FIG. 5

## TO CHECK/ADJUST CONTROL CABLES

The control cables attached to the auger drive lever and traction drive lever may need to be adjusted before you use your snow thrower.

For instructions on checking or adjusting the control cables, see To Adjust The Clutch Control Cables paragraph on page 19.



# ASSEMBLY

## TO INSTALL THE SHIFTER LEVER KNOB

- Stand the snow thrower up on the front of the auger housing, as shown in Fig. 6A.
- Cut the plastic tie which holds the shifter lever assembly to the shift bracket (Fig. 6B).
- Remove the locknut, washer, spring and bolt (Fig. 6D).
- Reposition the shifter lever into the slot in the control panel, as shown in Fig. 6C and reinstall the bolt, spring, washer and locknut.
- Tighten the locknut until 1/8" to 3/16" (2 or 3 threads) of the bolt protrude past the locknut.
- Thread the shifter lever knob onto the threaded end of the shifter lever until it is tight (Fig. 6D).
- Move the shifter lever through all the speeds to ensure proper tension of the spring. If the shifter lever sticks in any of the notches, loosen the locknut 1/4 turn at a time until the shifter lever moves freely.

## TO INSTALL HEADLIGHT

The headlight is mounted on right side of upper handle and is installed upside down for shipping purposes.

- Remove the pivot bolt (Fig. 7A), place headlight in correct position (as shown in Fig. 7B and in Fig. 2) and retighten nut.
- Tie the headlight cable to upper and lower handles with the plastic cable ties supplied in the parts bag by threading the pointed ends of each tie through the square ends and pulling tightly around the headlight cable and the handle.

**NOTE:** One side of the plastic tie has small notches in it, while the other side is smooth. The notched side must be on the inside of the loop which is formed when the ends are put together.

- Try to loosen the cable tie. If it can be loosened, it has been attached with the smooth side on the inside of the loop. Remove the cable tie and reverse its direction.
- Cut off excess cable tie.

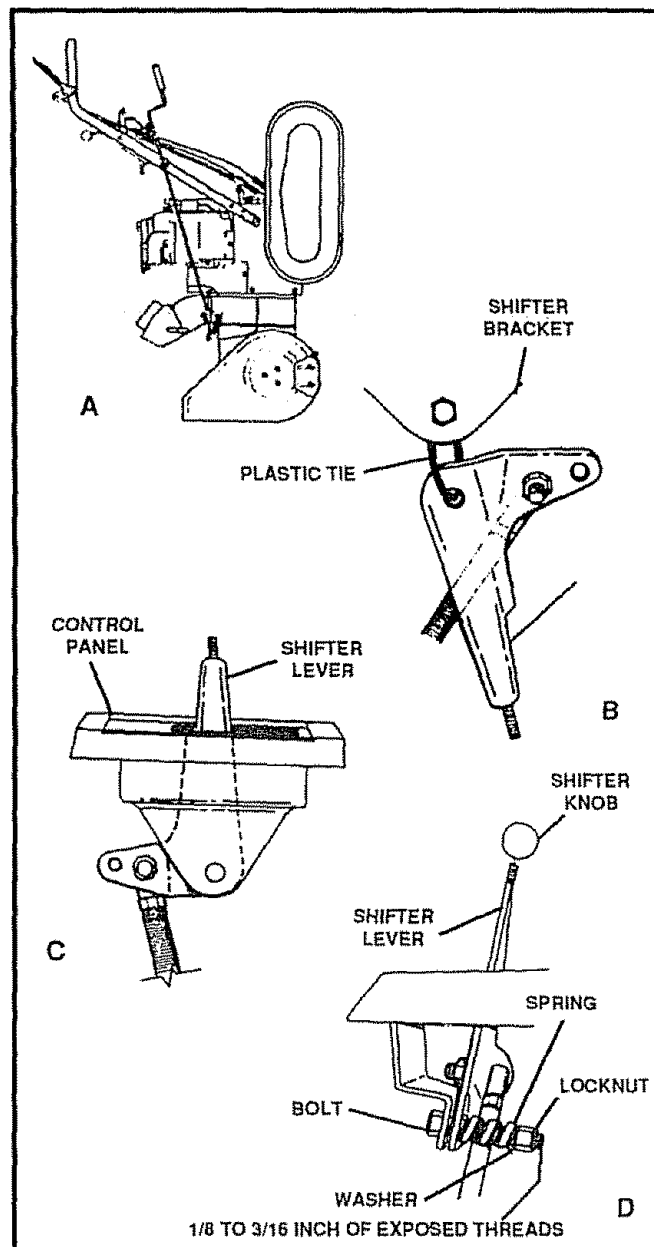

FIG. 6

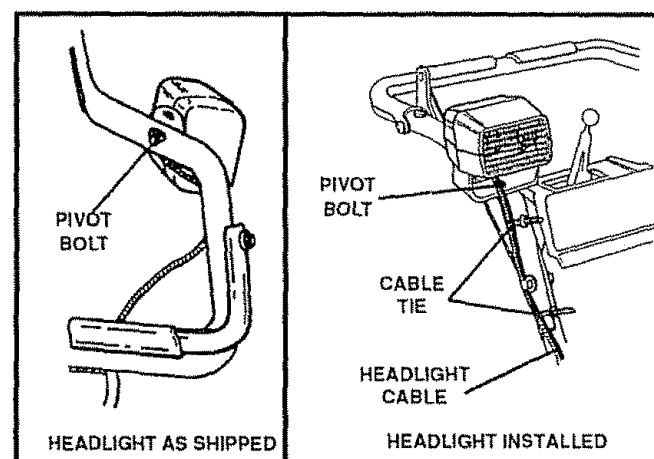

FIG. 7A

FIG. 7B

# ASSEMBLY

## TO INSTALL CHUTE ASSEMBLY TO CHUTE FLANGE

- Remove the chute assembly from the carton.
- Using a 1/2 inch wrench or adjustable wrench, remove the three (3) nuts, lockwashers, flatwashers and carriage bolts from the chute flange.
- Place the chute assembly over the outside of the chute flange so that the "A" on the chute assembly is next to the "A" on the chute flange. This will align all three holes correctly.
- From the inside of the chute flange, insert the three (3) carriage bolts (removed earlier) through the three square holes. The square part of the carriage bolts should fit into the square holes in the chute flange.
- Install the three (3) flatwashers, lockwashers and nuts (removed earlier) on the carriage bolts.

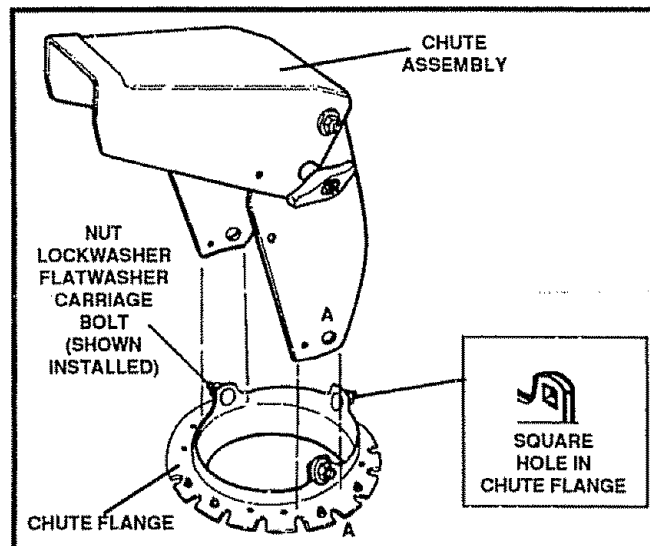

FIG. 8



**CAUTION: IF ALL THE THREE (3) CARRIAGE BOLTS CANNOT BE MOUNTED, THE HOLES ARE NOT ALIGNED CORRECTLY. CHECK THE POSITION OF THE LETTER "A's" ON THE CHUTE ASSEMBLY AND CHUTE FLANGE. THEY MUST BE NEXT TO EACH OTHER. IF LESS THAN THREE (3) HOLES LINE UP, YOU HAVE MOUNTED THE CHUTE ASSEMBLY INCORRECTLY AND SNOW COULD BE DISCHARGED TOWARD THE OPERATOR. RE-INSTALL THE CHUTE ASSEMBLY IF NECESSARY.**

# OPERATION

## KNOW YOUR SNOW THROWER

READ THIS OWNER'S MANUAL AND SAFETY RULES BEFORE OPERATING YOUR SNOW THROWER. Compare the illustrations with your snow thrower to familiarize yourself with the location of various controls and adjustments. Save this manual for future reference.

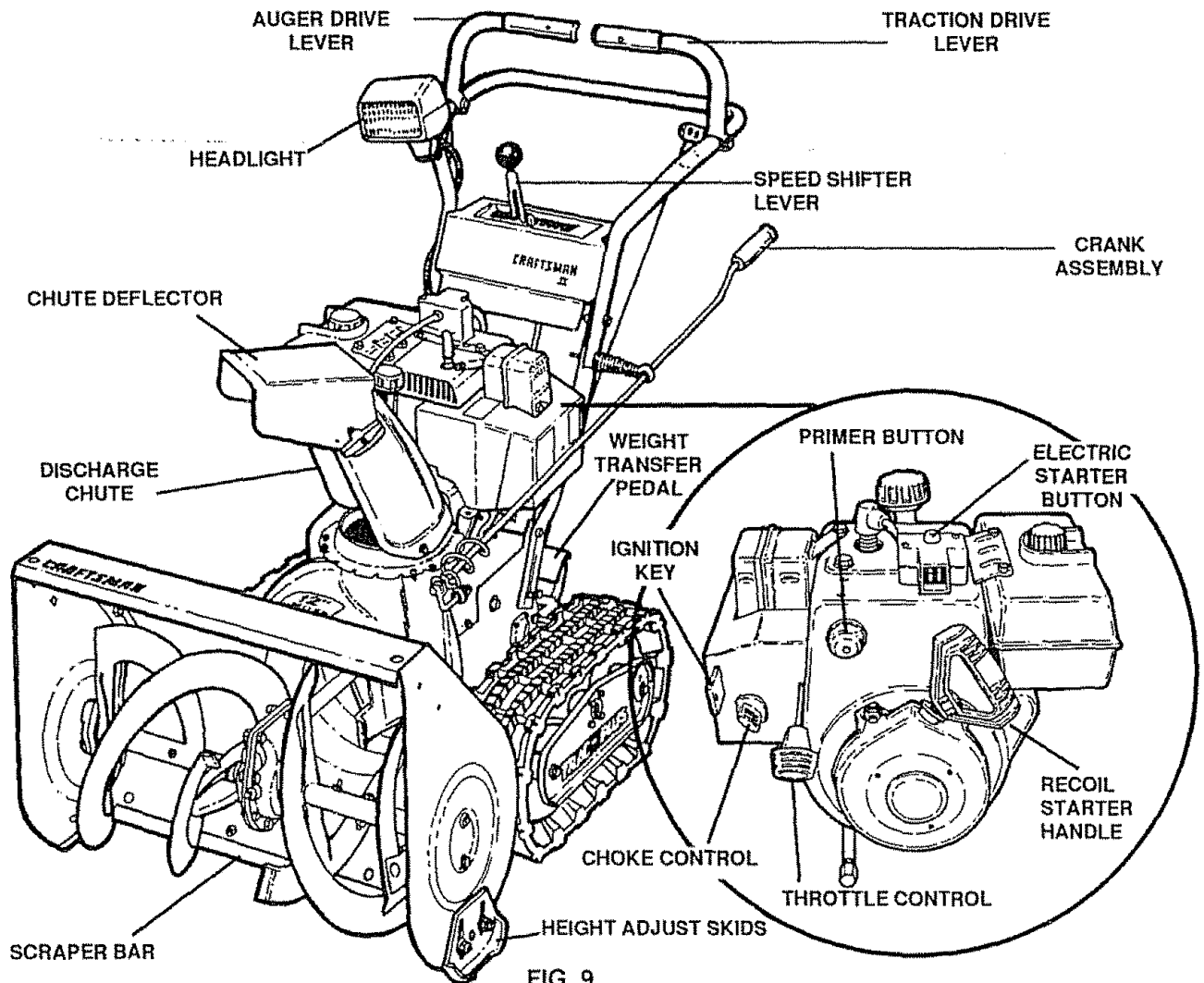

FIG. 9

SEARS TRAC-PLUS SNOW THROWERS conform to the safety standards of the American National Standards Institute.

**AUGER DRIVE LEVER** - Starts and stops the auger and impeller (snow gathering and throwing).

**TRACTION DRIVE LEVER** - Propels the snow thrower forward and in reverse.

**SPEED SHIFTER LEVER** - Selects the speed of the snow thrower (6 speeds forward and 2 speeds reverse).

**HEADLIGHT** - Turns on whenever the engine is running.

**CRANK ASSEMBLY** - Changes the direction of snow throwing through the discharge chute.

**CHUTE DEFLECTOR** - Changes the distance the snow is thrown.

**DISCHARGE CHUTE** - Changes the direction the snow is thrown.

**WEIGHT TRANSFER PEDAL** - Engage for heavy snow conditions, to keep the snow thrower from climbing drifts and hard-packed snow. When released, it eases transport of the snow thrower.

**HEIGHT ADJUST SKIDS** - Adjusts the ground clearance of the auger housing.

**IGNITION KEY** - Must be inserted to start the engine.

**ELECTRIC STARTER BUTTON** - Used to start the engine using the 120 V electric starter.

**RECOIL STARTER HANDLE** - Starts the engine manually.

**CHOKE CONTROL** - Used to start a cold engine.

**PRIMER BUTTON** - Injects the fuel directly into the carburetor or manifold for fast starts in cold weather.

**THROTTLE CONTROL** - Controls the engine speed.

# OPERATION



The operation of any snow thrower can result in foreign objects being thrown into the eyes, which can result in severe eye damage. Always wear safety glasses or eye shields while operating the snow thrower. We recommend standard safety glasses or wide vision safety mask for over your glasses available at SEARS Retail or Catalog Stores.

## HOW TO USE YOUR SNOW THROWER

### TO CONTROL SNOW DISCHARGE

- Turn the crank assembly to set the **direction** of the snow throwing.
- Loosen the wing knob on the chute deflector and move the deflector to set the **distance**. Move the deflector **UP** for more distance, **DOWN** for less distance. Then tighten the wing knob (Fig. 10).

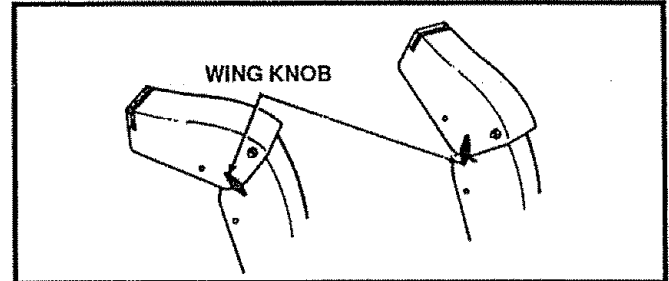

FIG. 10

### TO STOP YOUR SNOW THROWER

- To stop throwing snow, release the auger drive lever (See Fig. 12).
- To stop the track, release the traction drive lever.
- To stop the engine, push the throttle control lever to off and pull out the ignition key (See Fig. 11).

### TO MOVE FORWARD AND BACKWARD

- To shift, release the traction drive lever and move the speed shifter lever to the speed you desire. Ground speed is determined by snow conditions. Select the speed you desire by moving the speed shifter lever into the appropriate colored area on the control panel.

- Red - Wet, Heavy, Slushy, Extra Deep
- Amber - Moderate
- White - Very Light
- Green - Transport only

- Engage the traction drive lever (See Fig 12, left hand). As the snow thrower starts to move, maintain a firm hold on the handles, and guide the snow thrower along the clearing path. Do not attempt to push the snow thrower.
- To move the snow thrower backward, move the speed shifter lever into first or second reverse and engage the traction drive lever (left hand).

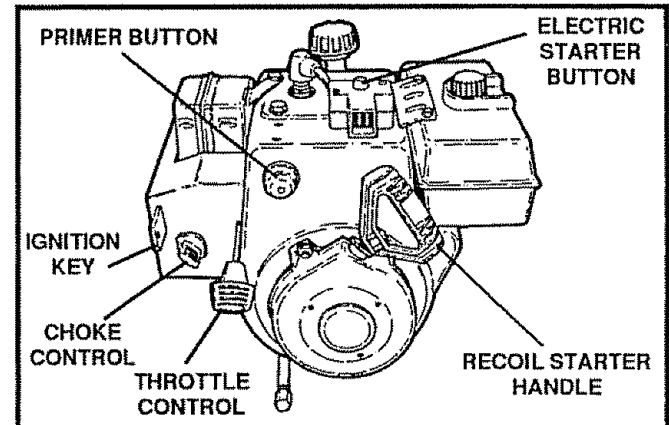

FIG. 11

**IMPORTANT:** DONOTMOVE THE SPEED SHIFTER LEVER WHILE THE TRACTION LEVER IS DOWN.

### TO THROW SNOW

- Push down the auger drive lever (See Fig. 12, right hand).
- Release to stop throwing snow.

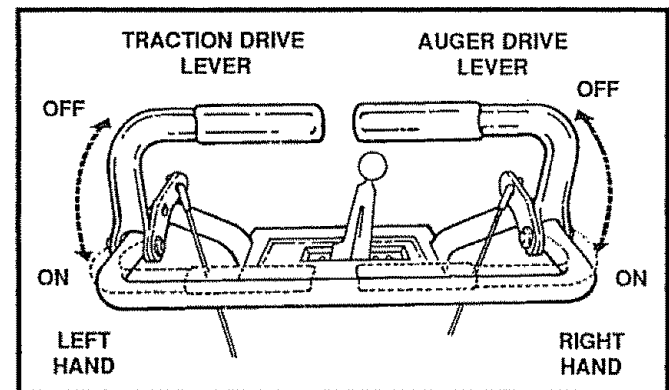

FIG. 12



**CAUTION: READ OWNER'S MANUAL BEFORE OPERATING MACHINE. NEVER DIRECT DISCHARGE TOWARD BYSTANDERS. STOP THE ENGINE BEFORE UNCLOGGING DISCHARGE CHUTE OR AUGER HOUSING AND BEFORE LEAVING THE MACHINE.**

# OPERATION

## TO USE WEIGHT TRANSFER SYSTEM

In hard packed or heavy snow conditions, conventional snow throwers tend to ride up and leave uneven mounds of snow behind. For these conditions, your new tracked snow thrower has a unique weight transfer system (See Fig. 13) designed to minimize ride-up.

Stepping on the weight transfer pedal shifts more weight to the auger housing. This weight transfer keeps the snow thrower in contact with the ground and reduces ride-up on ice and snow.

In lighter snow conditions or when transporting, you should release the weight transfer system for easier steering.

- To use the weight transfer, hold the upper handle firmly and push down on the weight transfer pedal (See Fig. 13) with the ball of your foot.
- To release, pull up on the weight transfer pedal with the top of your foot.

**NOTE:** The weight transfer system will not work if the auger housing height adjust skids are adjusted to the highest position.

## BEFORE STARTING THE ENGINE

### FILL/ ADD OIL:

The engine on this snow thrower was shipped **without oil**. Add oil before you start the engine. Remove the oil fill cap/dipstick and fill the crank case to **FULL** line on dipstick (26 ounces) (See Fig. 14) with S.A.E. 10 W-30 motor oil (or equivalent). **Do not overfill**. Tighten the fill cap/dipstick securely each time you check the oil level.

**NOTE:** S.A.E. 5W-30 motor oil may be used to make starting easier in areas where temperature is consistently 20° F or lower.

### FILL GAS:

**WARNING:** Experience indicates that alcohol blended fuels (called gasohol or using ethanol or methanol) can attract moisture which leads to separation and formation of acids during storage. Acidic gas can damage the fuel system of an engine while in storage.

To avoid engine problems, the fuel system should be emptied before storage for 30 days or longer. Start the engine and let it run until the fuel lines and carburetor are empty. Use the carburetor bowl drain to empty residual gasoline from the float chamber (See Fig. 42). Use fresh fuel next season. (See Storage instructions for additional information.)

Never use engine or carburetor cleaner products in the fuel tank or permanent damage may occur.

Fill the fuel tank with clean, fresh, unleaded grade automotive gasoline. Be sure that the container you pour the gasoline from is clean and free from rust or other

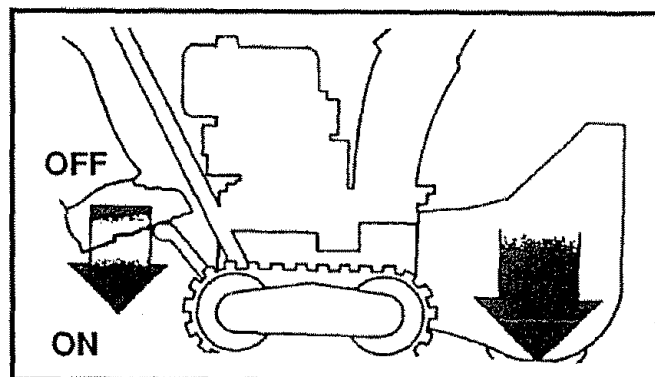

FIG.13

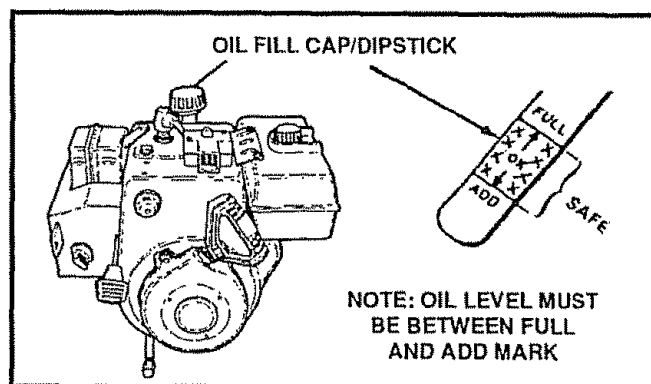

FIG.14

foreign particles. Never use gasoline that may be stale from long periods of storage in the container.



**CAUTION: GASOLINE IS FLAMMABLE AND CAUTION MUST BE USED WHEN HANDLING OR STORING IT.**

**DO NOT FILL FUEL TANK WHILE SNOW THROWER IS RUNNING, WHEN IT IS HOT, OR WHEN SNOW THROWER IS IN AN ENCLOSED AREA.**

**KEEP AWAY FROM OPEN FLAME OR AN ELECTRICAL SPARK AND DO NOT SMOKE WHILE FILLING THE FUEL TANK.**

**NEVER FILL THE TANK COMPLETELY. FILL THE TANK TO WITHIN 1/4" - 1/2" FROM THE TOP TO PROVIDE SPACE FOR EXPANSION OF FUEL.**

**ALWAYS FILL FUEL TANK OUTDOORS AND USE A FUNNEL OR SPOUT TO PREVENT SPILLING.**

**MAKE SURE TO WIPE UP ANY SPILLED FUEL BEFORE STARTING THE ENGINE.**

**STORE GASOLINE IN A CLEAN, APPROVED CONTAINER AND KEEP THE CAP IN PLACE ON THE CONTAINER.**

# OPERATION

## TO STOP ENGINE

- To stop engine, move the throttle control lever to STOP position and remove key. Keep the key in a safe place. The engine will not start without the key.

## TO START ENGINE (Electric Starter)

Be sure that the engine has sufficient oil. The snow thrower engine is equipped with a 120 volt A.C. electric starter and recoil starter. Before starting the engine, be certain that you have read the following information:

### COLD START (See Fig. 15)

- Be sure the auger drive and traction drive levers are in the disengaged RELEASED position.
- Move the throttle control up to FAST position.
- Remove the keys from the plastic bag. Insert one key into the ignition slot. Be sure it snaps into place. DO NOT TURN KEY. Keep the second key in a safe place.
- Rotate the choke knob to FULL choke position.
- Connect the power cord to the switch box on the engine.
- Plug the other end of the power cord into a three hole, grounded 120 volt A.C. receptacle.
- Press primer button in cold weather. Press two-three times while keeping your finger over the vent hole on the primer button. Additional priming may be necessary for the first start if the temperature is below 15° F.
- Push down on the starter button until the engine starts. Do not crank for more than 10 seconds at a time. This electric starter is thermally protected. If overheated it will stop automatically and can be restarted only when it has cooled to a safe temperature (a wait of about 5 to 10 minutes is required).
- When the engine starts, release the starter button and slowly rotate the choke to OFF position. If the engine falters, rotate the choke to FULL and then gradually to OFF.
- Disconnect the power cord from the receptacle first and then from switch box on engine.

**NOTE:** Allow the engine to warm up for a few minutes because the engine will not develop full power until it reaches operating temperature.

- Run the engine at full throttle (FAST) speed when throwing snow.

### WARM START

If restarting a warm engine after a short shutdown, leave choke at OFF and do not push the primer button.

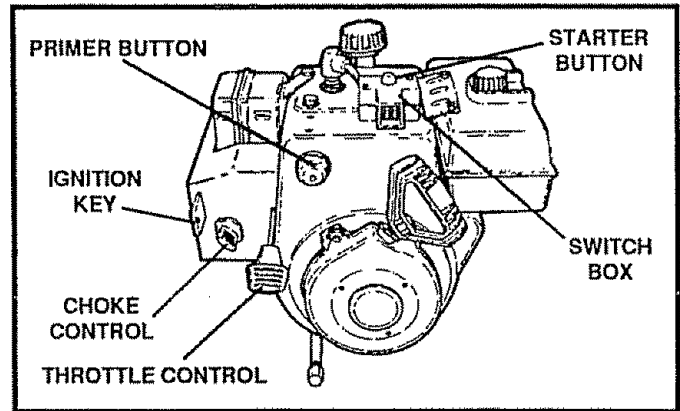

FIG.15



**CAUTION: THIS STARTER IS EQUIPPED WITH A THREE-WIRE POWER CORD AND PLUG AND IS DESIGNED TO OPERATE ON 120 VOLT AC HOUSEHOLD CURRENT. IT MUST BE PROPERLY GROUNDED AT ALL TIMES TO AVOID THE POSSIBILITY OF ELECTRICAL SHOCK, WHICH MAY BE INJURIOUS TO OPERATOR. FOLLOW ALL INSTRUCTIONS CAREFULLY AS SET FORTH IN THE "TO START ENGINE" SECTION. DETERMINE THAT YOUR HOUSE WIRING IS A THREE-WIRE GROUNDED SYSTEM. ASK A LICENSED ELECTRICIAN IF YOU ARE NOT SURE. IF YOUR HOUSE WIRE SYSTEM IS NOT A THREE-WIRE SYSTEM, DO NOT USE THIS ELECTRIC STARTER UNDER ANY CONDITIONS. IF YOUR SYSTEM IS GROUNDED AND A THREE-HOLE RECEPTACLE IS NOT AVAILABLE AT THE POINT YOUR STARTER WILL NORMALLY BE USED, ONE SHOULD BE INSTALLED BY A LICENSED ELECTRICIAN.**

**WHEN CONNECTING 120 VOLT AC POWER CORD, ALWAYS CONNECT THE CORD TO THE SWITCH BOX ON THE ENGINE FIRST, THEN PLUG THE OTHER END INTO THE THREE-HOLE GROUNDED RECEPTACLE.**

**WHEN DISCONNECTING POWER CORD, ALWAYS UNPLUG THE END IN THE THREE-HOLE GROUNDED RECEPTACLE FIRST.**

# OPERATION



**CAUTION: NEVER RUN ENGINE INDOORS OR IN ENCLOSED, POORLY VENTILATED AREAS. ENGINE EXHAUST CONTAINS CARBON MONOXIDE, AN ODORLESS AND DEADLY GAS. KEEP HANDS, FEET, HAIR AND LOOSE CLOTHING AWAY FROM ANY MOVING PARTS ON ENGINE AND SNOW THROWER.**

**WARNING: TEMPERATURE OF MUFFLER AND NEARBY AREAS MAY EXCEED 150° F. AVOID THESE AREAS.**

**DO NOT ALLOW CHILDREN OR YOUNG TEENAGERS TO OPERATE OR BE NEAR SNOW THROWER WHILE IT IS OPERATING.**

## TO STOP ENGINE

- To stop engine, move the throttle control lever to STOP position and remove key. Keep the key in a safe place. The engine will not start without the key.

## TO START ENGINE (Recoil Starter)

Be sure that the engine has sufficient oil. Before starting the engine, be certain that you have read the following information:

### COLD START (See Fig. 16)

- Be sure the auger drive and the traction drive levers are in the disengaged RELEASED position.
- Move the throttle control up to FAST position.
- Push the key into the ignition slot. Be sure it snaps into place. Do not turn key. Remove plastic bag and extra key.
- Rotate choke control to FULL choke position.
- Press the primer button two or three times, while keeping your finger over the vent hole on the primer button. Additional priming may be necessary for the first start if the temperature is below 15° F.
- Pull the starter handle rapidly. Do not allow the handle to snap back, but allow it to rewind slowly while keeping a firm hold on the starter handle.
- As the engine warms up and begins to operate evenly, rotate the choke knob slowly to OFF position. If the engine falters, return to FULL choke, then slowly move to OFF choke position.

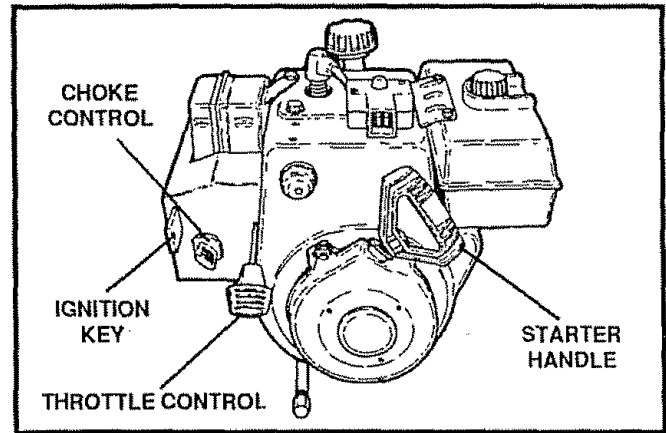

FIG.16

**NOTE:** Allow the engine to warm up for a few minutes because the engine will not develop full power until it reaches operating temperature.

- Run the engine at or near the top speed when throwing snow.

## WARM START

If restarting a warm engine after a short shutdown, leave choke at OFF and do not push the primer button.

## FROZEN RECOIL STARTER

If the starter is frozen and will not turn engine:

- Pull as much rope out of the starter as possible.
- Release the starter handle and let it snap back against the starter.

If the engine still fails to start, repeat. If continued attempts do not free starter, follow the electric cold start procedures to start.

To help prevent possible freeze-up of recoil starter and engine controls, proceed as follows after each snow removal job.

- **With the engine running**, pull the starter rope hard with a continuous full arm stroke three or four times. Pulling of starter rope will produce a loud clattering sound. This is not harmful to the engine or starter.
- **With the engine not running**, wipe all snow and moisture from the carburetor cover in area of control levers. Also move throttle control, choke control, and starter handle several times and leave in off position. Leave choke in Full position.

# OPERATION

## SNOW THROWING TIPS

- For maximum snow thrower efficiency, adjust ground speed, not throttle. If the track slips, reduce forward speed. The engine is designed to deliver maximum performance at full throttle and should be run at this power setting at all times.
- Most efficient snow throwing is accomplished when the snow is removed immediately after it falls.
- For complete snow removal, slightly overlap each path previously taken.
- The snow should be discharged down wind whenever possible.
- For normal usage, set the skids so that the scraper bar is 1/8" above the skids. For extremely hard-packed snow surfaces, adjust the skids upward so that the scraper bar touches the ground.
- On gravel or crushed rock surfaces, set the skids at 1-1/4" below the scraper bar (see To Adjust Skids Height paragraph on page 19). Rocks and gravel must not be picked up and thrown by the machine.
- If the front of the snow thrower has a tendency to raise, reduce the ground speed and engage the weight transfer system.
- After the snow throwing job has been completed, allow the engine to idle for a few minutes, which will melt snow and accumulated ice off the engine.
- Clean the snow thrower thoroughly after each use.
- Remove ice and snow accumulation and all debris from the entire snow thrower, and flush with water (if possible) to remove all salt or other chemicals. Wipe snow thrower dry.



**CAUTION: DO NOT ATTEMPT TO REMOVE ANY ITEM THAT MAY BECOME LODGED IN AUGER WITHOUT TAKING THE FOLLOWING PRECAUTIONS:**

- **RELEASE AUGER DRIVE AND TRACTION DRIVE LEVERS.**
- **MOVE THROTTLE LEVER TO STOP POSITION.**
- **REMOVE (DO NOT TURN) IGNITION KEY.**
- **DISCONNECT SPARK PLUG WIRE.**
- **DO NOT PLACE YOUR HANDS IN THE AUGER OR DISCHARGE CHUTE. USE A PRY BAR.**



# MAINTENANCE

## GENERAL RECOMMENDATIONS

The warranty on this snow thrower does not cover items that have been subjected to operator abuse or negligence. To receive full value from the warranty, operator must maintain snow thrower as instructed in this manual.

Some adjustments will need to be made periodically to properly maintain your snow thrower.

All adjustments in the Service and Adjustments section of this manual should be checked at least once each season.

### AFTER FIRST USE

- Check the tracks for tension and adjust if necessary (See To Adjust Track paragraph on page 24). Check the track adjustment and fasteners regularly.
- Be sure that all fasteners are tight.

### AS REQUIRED

The following adjustments should be performed more than once each season.

- Auger and Track Drive Belts should be adjusted after the first 2 to 4 hours of use, again about mid-season and twice each season thereafter. See To Adjust Belts paragraph on page 20.
- All screws and nuts should be checked often to make sure they are tight, preferably after each use.

## SNOW THROWER

### LUBRICATION - EVERY TEN HOURS

- Chain and Sprockets - Oil chains and sprockets (See Fig 17) with 10W-30 oil (or equivalent) after 10 hours use and at the end of each season.
- Weight Transfer System - Coat weight transfer plate (See Fig. 18) with clinging type grease, such as Lubriplate, every ten (10) hours and before storage.
- Auger Shaft - Using a hand grease gun, lubricate the auger shaft zerk fittings (See A, Fig. 19) every ten (10) operating hours. Each time a shear bolt is replaced (see To Replace the Auger Shear Bolt (on page 24), the auger shaft MUST be greased.
- For storage or when replacing shear bolts, remove shear bolts and lubricate auger shaft zerks. Rotate auger several times on shaft and reinstall shear bolts.

### LUBRICATION - NOT REQUIRED

- Hex Shaft and Gears - Hex shaft and gears require no lubrication. All bearings and bushings are lubricated for lifetime and require no maintenance (See Fig. 20).

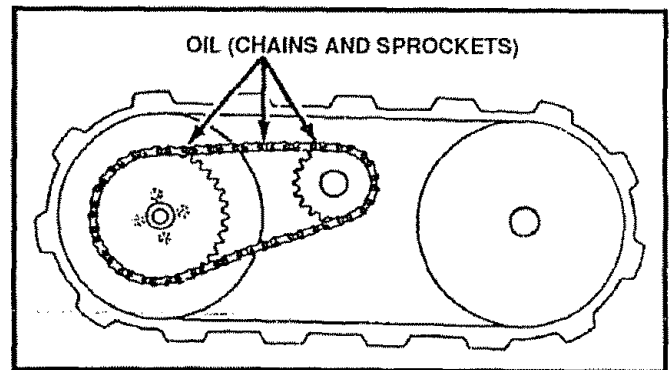

FIG. 17

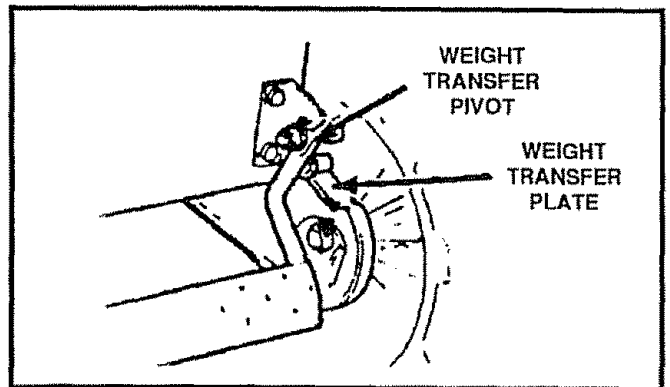

FIG. 18

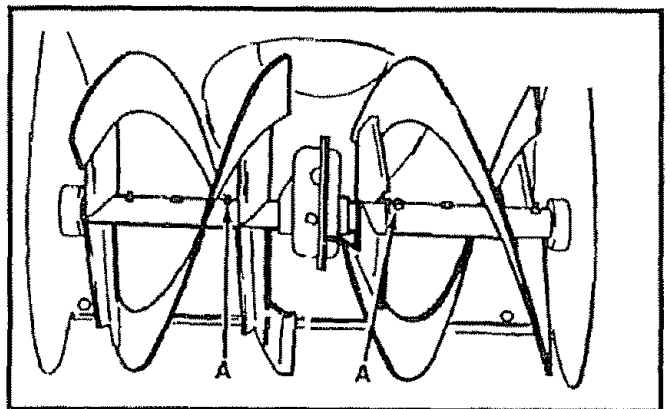

FIG. 19

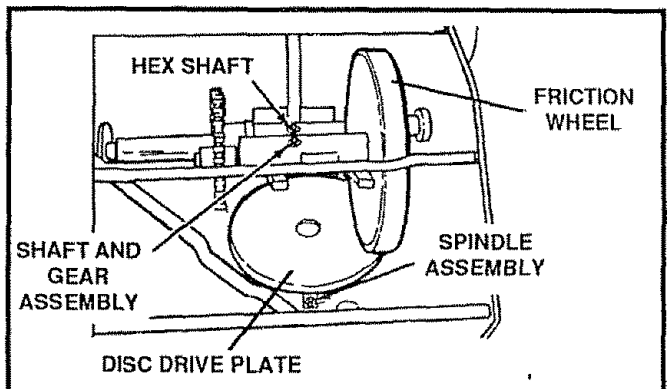

FIG. 20

# MAINTENANCE

**NOTE:** Any greasing or oiling of the above components can cause contamination of the friction wheel. If the disc drive plate or friction wheel come in contact with grease or oil, damage to the friction wheel will result.

Should grease or oil come in contact with the disc drive plate or friction wheel, be sure to clean the plate and wheel thoroughly.

**NOTE:** For storage, the hex shaft and gears should be wiped with 10W-30 motor oil to prevent rusting (See Fig. 19).

- Auger Gear Box - The auger gear box has been factory lubricated for life. If for some reason lubricant should leak out, have auger gear case checked by a competent repairman.

## ENGINE LUBRICATION

Check the crankcase oil level (See Fig. 21) before starting the engine and after each five (5) hours of continuous use. Add S.A.E. 10W-30 motor oil or equivalent. Tighten fill cap/dipstick securely each time you check the oil level. S.A.E. 5W-30 motor oil may be used to make starting easier in areas where temperature is consistently 20° F or lower.

Change the oil after first two hours of operation and every 25 hours thereafter or at least once a year if the snow thrower is not used for 25 hours (See Fig. 22).

- Position snow thrower so that the oil drain plug is lowest point on the engine. Remove oil drain plug and oil fill cap/dipstick. Drain oil into a suitable container. Oil will drain more freely when warm.
- Replace oil drain plug and tighten securely. Refill crankcase with S.A.E. 10W-30 motor oil (or equivalent). S.A.E. 5W-30 motor oil may be used to make starting easier in areas where temperature is consistently 20° F or lower.

## SPARK PLUG

- Make sure that the spark plug is tightened securely into the engine and the spark plug wire is attached to the spark plug.
- If a torque wrench is available, torque plug to 18 to 23 foot pounds.
- Clean the area around the spark plug base before removal to prevent dirt from entering the engine.
- Clean the spark plug and reset the gap periodically.

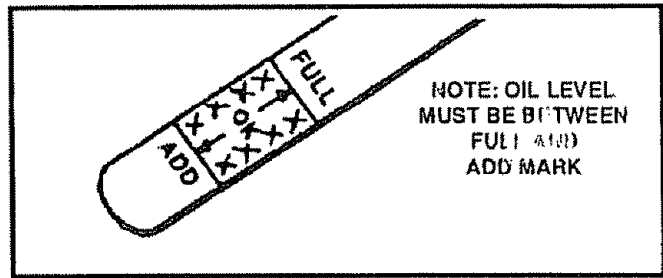

FIG. 21

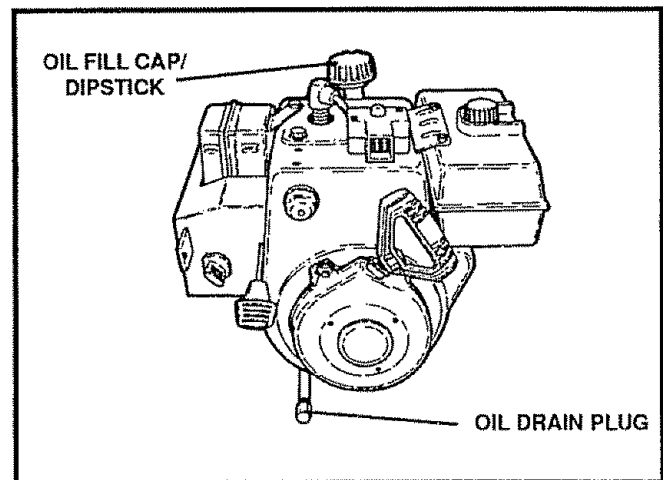

FIG. 22

# SERVICE AND ADJUSTMENTS



**CAUTION: ALWAYS DISCONNECT THE SPARK PLUG WIRE AND TIE BACK AWAY FROM THE PLUG BEFORE MAKING ANY ADJUSTMENTS OR REPAIRS.**

## TO ADJUST SKIDS HEIGHT

This snow thrower is equipped with two height adjustment skids, located on the outside of the auger housing (See Fig. 23). These skids elevate the front of the snow thrower.

For normal hard surfaces, adjust the skids as follows:

- Make sure the snow thrower is on a hard, level surface and the weight transfer system lever is released. See page 13.
- Place extra shear bolts supplied (found in parts bag) under each end of the scraper bar near but not under the skids.
- Loosen the skid mounting nuts (See Fig. 23) and push the skids down until they touch the ground. Retighten the mounting nuts.

For rocky or uneven surfaces, raise the front of the snow thrower by moving the skids down. This will help prevent rocks and other debris from being picked up and thrown by the auger.

**NOTE:** If the skids are at the maximum height, the weight transfer system will not work.

## TO ADJUST SCRAPER BAR

After considerable use, the metal scraper bar will have a definite wear pattern. The scraper bar in conjunction with the skids should always be adjusted to allow 1/8" between the scraper bar and the sidewalk or area to be cleaned.

- Position the snow thrower on a level surface
- Loosen the carriage bolts and nuts securing the scraper bar to the auger housing.
- Adjust the scraper bar to the proper position.
- Tighten the carriage bolts and nuts, making sure that the scraper bar is parallel with the working surface.
- After extended operation, the scraper bar may be reversed. If the scraper bar must be replaced due to wear, remove the carriage bolts and nuts and install a new scraper bar.

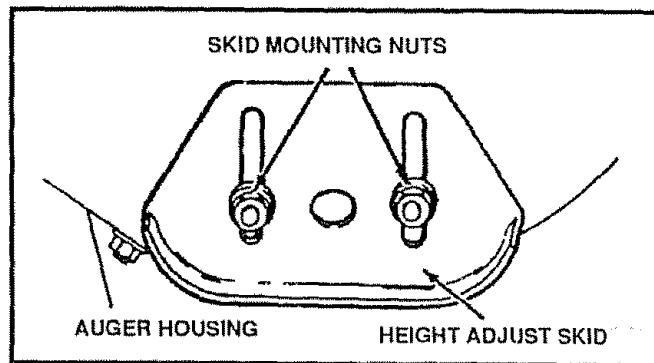

FIG. 23



**CAUTION: BE CERTAIN TO MAINTAIN PROPER GROUND CLEARANCE FOR YOUR PARTICULAR AREA TO BE CLEARED. OBJECTS SUCH AS GRAVEL, ROCKS OR OTHER DEBRIS, IF STRUCK BY THE IMPELLER, MAY BE THROWN WITH SUFFICIENT FORCE TO CAUSE PERSONAL INJURY, PROPERTY DAMAGE OR DAMAGE TO THE SNOW THROWER.**

## TO ADJUST CHUTE CRANK ASSEMBLY

If you cannot rotate the chute crank fully to the left and to the right, you need to adjust the chute crank (See Fig. 24).

- Loosen both 1/2" nuts on the crank adjusting rod (using 3/4" wrenches).
- Rotate the adjusting rod in or out to allow about 1/8" clearance between the notch in the flange and the outer diameter of the worm.
- Once this clearance is set, tighten the nuts.

**NOTE:** Be sure the crank does not touch the side of the engine or the cover will be scratched

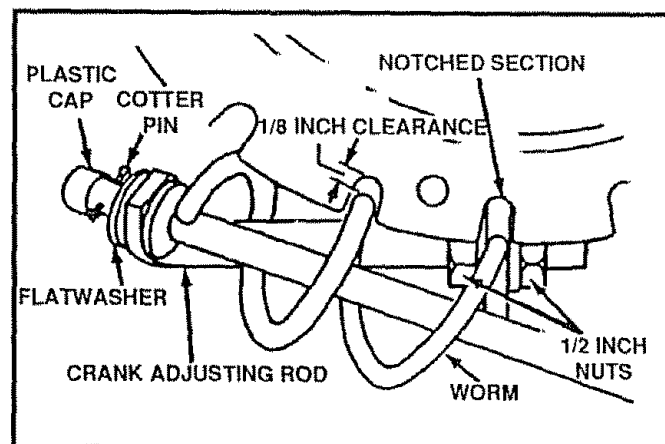

FIG. 24

# SERVICE AND ADJUSTMENTS

## TO ADJUST THE CLUTCH CONTROL CABLES

Periodic adjustment of the cables may be required due to normal stretch and wear on the belts. To check for correct adjustment, the control lever must be in the full forward position, resting on the plastic bumper. The control cables are correctly adjusted when the center of the "Z" fitting is in the center of the hole and there is no droop in the cable (See Fig. 25).

If adjustment is necessary:

- Push the cable through the spring (See Fig. 26) to expose the threaded portion of the cable.
- Hold the square end of the threaded portion with pliers and adjust the locknut in or out until the excess slack is removed.
- Pull the cable back through the spring and connect the cable.
- Do the same for the other lever cable.

**NOTE:** Whenever the traction drive or auger belts are adjusted or replaced, the cables will need to be adjusted.

## TO ADJUST BELTS

Belts stretch during normal use. If you need to adjust the belts due to wear or stretch, proceed as follows:

### TRACK DRIVE BELT (See Fig. 28)

The track drive belt has constant spring pressure and does not require adjustment. Check the clutch control cable adjustment before replacing the belt.

Replace the track drive belt if it is still slipping (see To Replace Belts paragraph on page 22).

### AUGER DRIVE BELT (See Fig. 28)

If your snow thrower will not discharge snow, check the control cable adjustment. If it is correct then check the condition of the auger drive belt. It may be loose or damaged. If it is damaged, replace it. See To Replace Belts paragraph on page 21. If the auger drive belt is loose, adjust as follows:

- Disconnect the spark plug wire.
- Remove the belt cover.
- Loosen the nut on the idler pulley (See Fig. 27) and move the pulley toward the belt about 1/8".
- Tighten the nut.
- Press the auger drive lever. Check the tension on the belt (opposite idler pulley). The belt should deflect about 1/2" with moderate pressure (See Fig. 27).

**NOTE:** You may have to move the idler pulley more than once to obtain the correct tension.

- Replace the belt cover.
- Check the clutch control cable adjustment.
- Reconnect the spark plug wire.

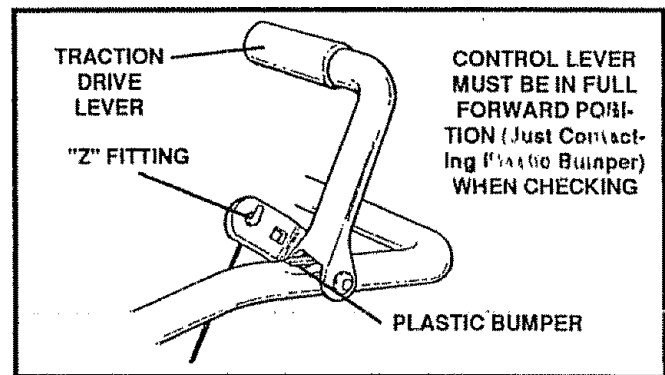

FIG. 25

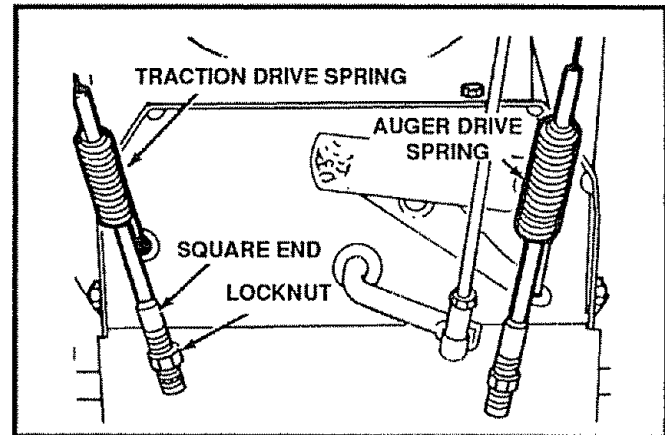

FIG. 26

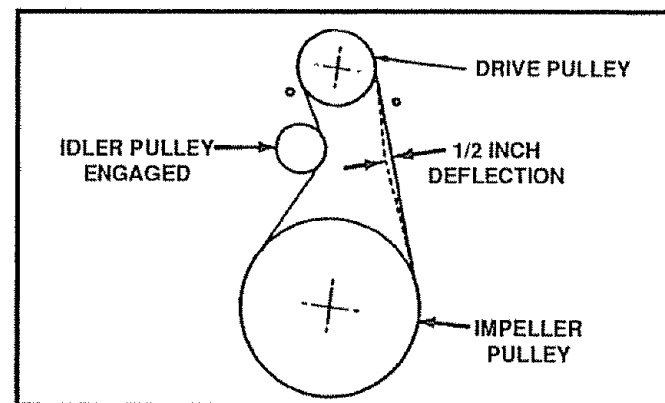

FIG. 27

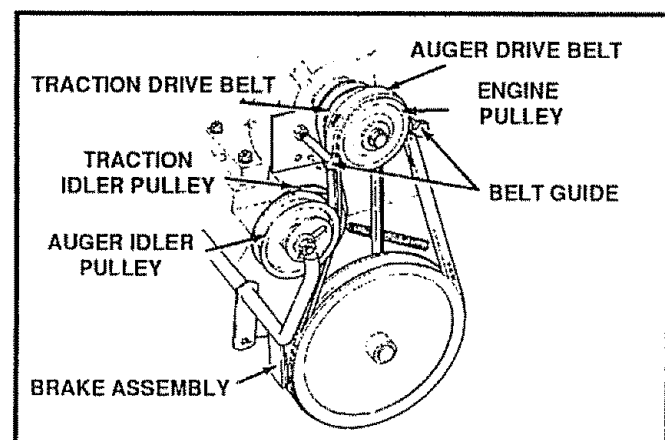

FIG. 28

# SERVICE AND ADJUSTMENTS

## TO REPLACE BELTS

The drive belts on this snow thrower are of special construction and should be replaced with original equipment belts available from your nearest SEARS Store or Service Center.

You will need the assistance of a second person while replacing the belts.

Drain the gasoline from the fuel tank by removing the fuel line. Drain the gas and reinstall fuel line.



**CAUTION: DRAIN THE GASOLINE OUT DOORS, AWAY FROM FIRE OR FLAME.**

## AUGER DRIVE BELT

If your snow thrower will not discharge snow, and the auger drive belt is damaged, replace it as follows:

- Disconnect the spark plug wire.
- Remove the belt cover (See Fig. 29)
- Remove the auger drive engine pulley. Removing the engine pulley allows you to remove the belt without removing the belt guides (See Fig. 30).
- Remove plastic cap, cotter pin and washer from the wormed end of crank assembly (See Fig. 24).
- Remove crank assembly from adjusting rod and slide crank out of the way.
- Have someone hold up on the upper handles.
- Remove the top two bolts (See Fig. 29) holding the auger housing to the motor mount frame.
- The auger housing and motor frame will separate (pivoting on lower bolts).

**NOTE:** It may be necessary to slightly loosen the bottom nuts (See Fig. 29) to get the auger housing and motor mount to pivot.

- Bend the belt retainer tabs (See Fig. 31) away from the auger pulley.
- Remove the old auger belt and install new one.
- Pull up on the belt to hold it firmly in the "V" of the pulley and bend the belt retainers back into position leaving 1/16 to 1/8 inch clearance between the belt and the belt retainer tabs.
- Standing on the right side of the snow thrower, pull up the auger drive belt.
- Have someone engage the auger drive lever and pivot the motor mount frame back into position.

**NOTE:** Engaging the auger drive lever moves the auger brake out of the way.

- Reinstall the top two bolts that hold the auger housing to the motor mount frame and tighten the bottom two nuts if they were loosened.
- Place the auger drive belt on the engine pulley and reinstall the auger drive engine pulley.

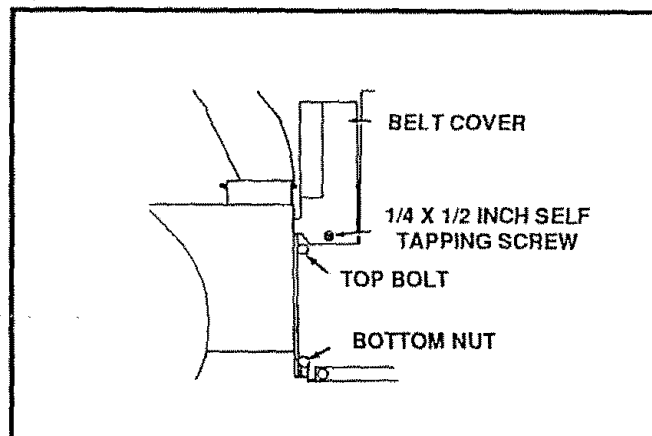

FIG. 29

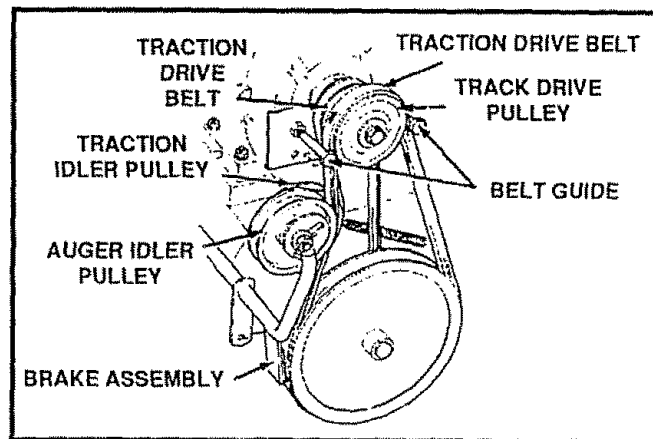

FIG. 30

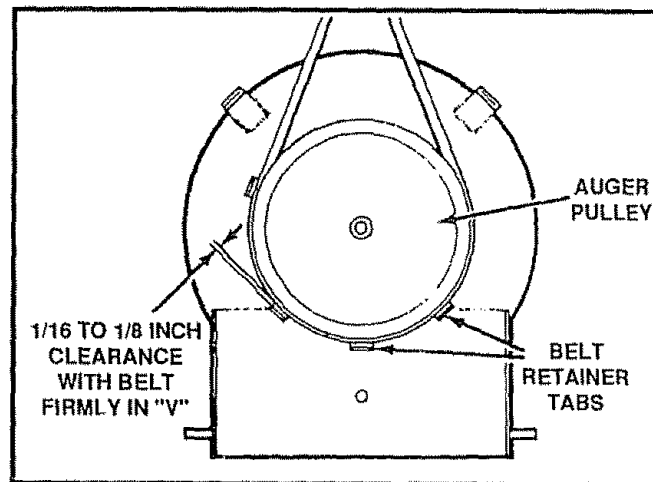

FIG. 31

- Adjust drive belt, see To Adjust Belts paragraph on page 20.
- Reinstall the removed parts in reverse order of removal.

# SERVICE AND ADJUSTMENTS

## TRACK DRIVE BELT

If your snow thrower will not move forward check the track drive belt for wear. If the track drive belt needs to be replaced, proceed as follows:

- Disconnect the spark plug wire.
- Remove the belt cover.
- Follow steps 4 through 9 of the Auger Drive Belt Replacement paragraph on page 21.
- Pull the spring loaded traction drive idler pulley (See Fig. 30) away from the traction drive belt.
- Remove the traction drive belt from the engine pulley.

**NOTE:** You may have to move the auger brake assembly (See Fig. 30) to remove the belt from the traction drive pulley.

- Install the replacement belt and reinstall the removed parts in reverse order of removal.

## TO ADJUST THE FRICTION WHEEL

If the snow thrower will not move forward, you need to check the track drive belt, the traction drive cable or the friction wheel. If the friction wheel is damaged, it will need to be replaced. See the To Replace Friction Wheel paragraph on page 23. If the friction wheel is not worn, check the adjustment, as follows:

- Disconnect spark plug wire.
- Drain the gasoline from the gas tank.
- Stand snow thrower on end.
- Remove the bottom panel (See Fig. 32).
- Position the shifter lever in first (1) gear.
- Note the position of the friction wheel on the disc drive plate. The right side of the friction wheel should be 2-5/8" from the left outer side of the disc drive plate (See Fig. 33).

If adjustment is necessary:

- Loosen the jam nut "A" on the speed select rod. Remove the ball joint from the shifter bracket. Lengthen or shorten the rod by turning the adaptor to obtain the correct friction wheel position (See Fig. 34).
- Reinstall the ball joint and tighten the jam nut.
- Reinstall the bottom panel.

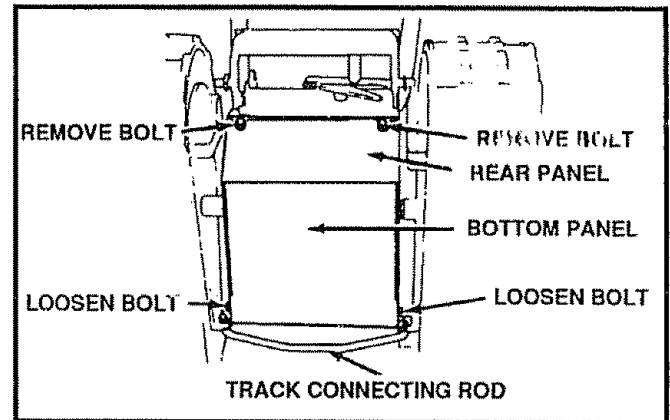

FIG. 32

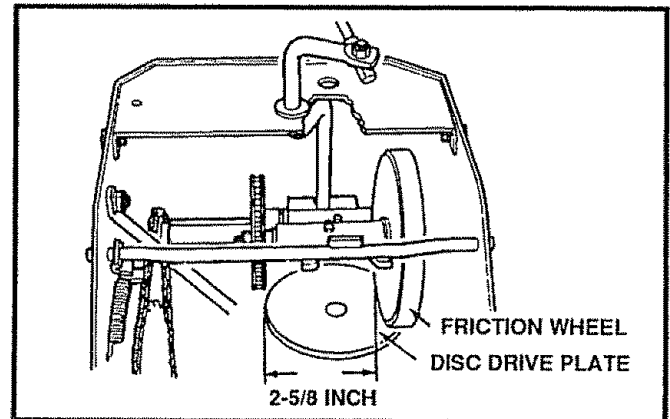

FIG. 33

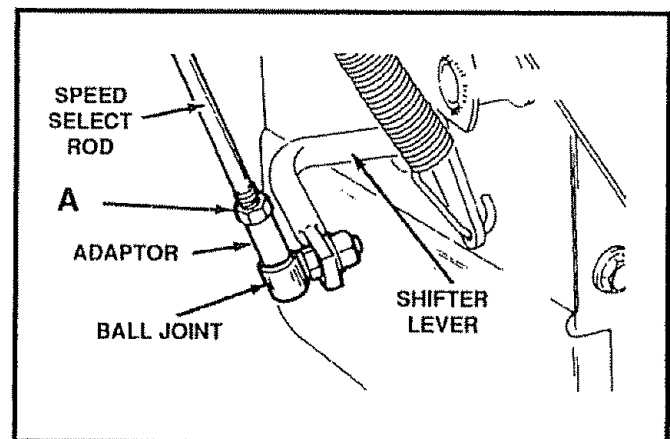

FIG. 34

# SERVICE AND ADJUSTMENTS

## TO REPLACE FRICTION WHEEL

If the snow thrower will not move forward, and the friction wheel is worn or damaged, you need to replace it, as follows: (First allow the engine to cool.)



**CAUTION: DRAIN GASOLINE OUTDOORS AWAY FROM FIRE OR FLAME.**

- Drain the gasoline from the fuel tank by removing the fuel line. Drain the fuel and reinstall the fuel line.
- Disconnect the spark plug wire.
- Stand the snow thrower up on the auger housing end (See Fig. 35).
- Remove the rear and bottom panels (See Fig. 35).

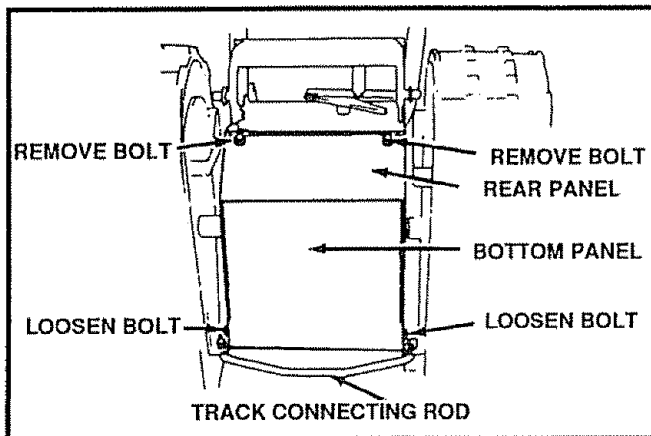

FIG. 35

- Hold the hex shaft with an 11/16 inch wrench (or an adjustable wrench) Place the wrench on the extreme right hand side of the hex shaft (See Fig. 36).
- Remove the 3/8 inch nut, lockwasher and flat-washer holding the wheel and hub assembly to the shaft.
- Remove the hub and wheel assembly and replace the friction wheel.

**NOTE:** Be sure the friction wheel is installed as it was removed. The hub should be inside recessed or cupped end and facing away from the clutch assembly. Be sure the 1/8 inch square key is in place and the thrust washer is completely on the shoulder of the shaft, NOT trapped between the shoulder and the thread.

- Reinstall the removed parts in reverse order of removal.

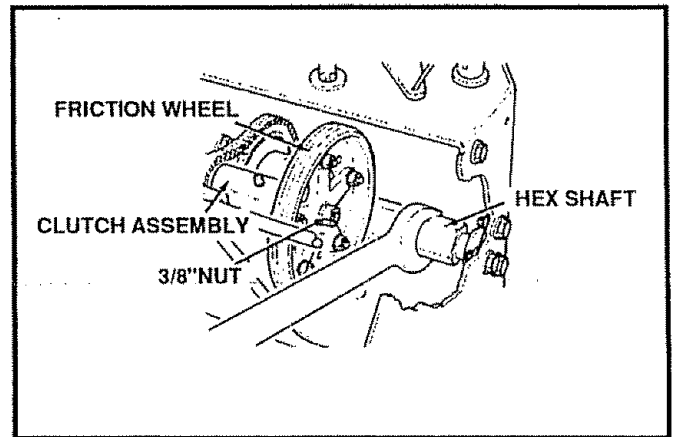

FIG. 36

# SERVICE AND ADJUSTMENTS

## TO REPLACE AUGER SHEAR BOLT

The augers are secured to the auger shaft with special bolts (See Fig. 37) that are designed to break (to protect the machine) if an object becomes lodged in the auger housing. Use of a harder bolt will destroy the protection provided by the shear bolt.

**IMPORTANT:** TO INSURE SAFETY AND PERFORMANCE LEVELS, ONLY ORIGINAL EQUIPMENT SHEAR BOLTS SHOULD BE USED.

To replace a broken shear bolt, proceed as follows:

- Move the throttle to STOP and turn off all controls.
- Disconnect the spark plug wire. Be sure all moving parts have stopped.
- Lubricate the auger shaft zerk fitting (see the Maintenance section, on pages 17-18).
- Align the hole in the auger with the hole in the auger shaft. Install the new shear bolt and locknut provided.
- Reconnect the spark plug wire.

## TO ADJUST TRACK

If the snow thrower does not move forward evenly and the track slips slightly, you need to check the track as follows:

- Measure the distance between the top of the side plate and the inside of the track. The distance should not be more than two (2) inches.

If the distance is greater, you need to adjust the track, as follows:

- Loosen the bolts (See Fig. 38, A) on both sides of the track assembly.
- Turn the cam washers equally on both sides.
- Adjust the track to reduce slack, so that the distance between the top of the side plate and the inside of the track is not greater than two (2) inches. Be sure the cam washers are adjusted evenly or the track will be twisted (See Fig 39). If the track becomes twisted, readjust the cam washers to the correct adjustment.

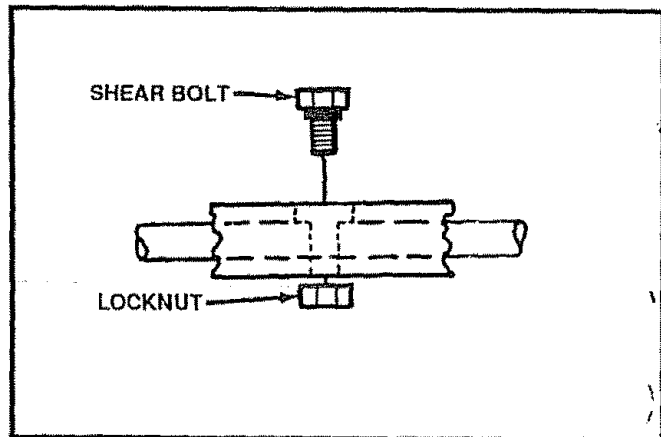

FIG. 37

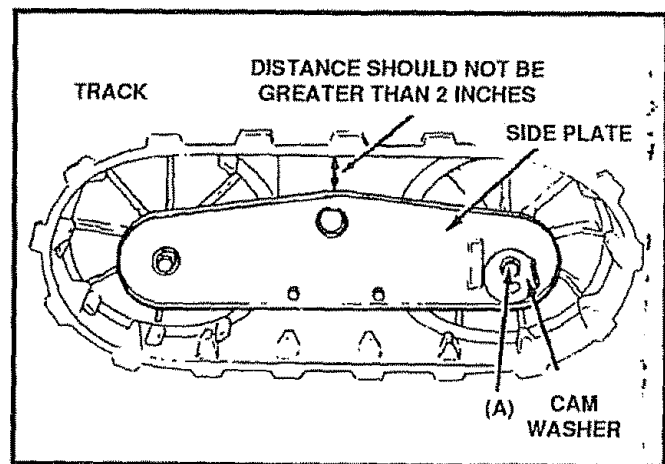

FIG. 38

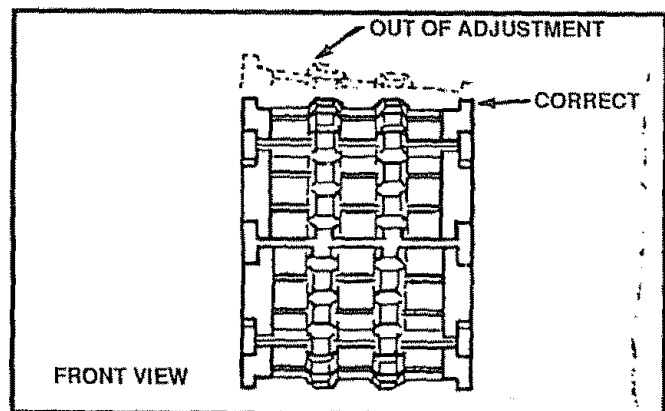

FIG. 39



# SERVICE AND ADJUSTMENTS

## TO ADJUST CARBURETOR

The carburetor (See Fig. 40 and Fig. 42) has been pre-set at the factory and readjustment should not be necessary. However, if the carburetor does need to be adjusted, proceed as follows:

- Close the high speed adjusting screw by hand.
- Do not overtighten.
- Then open it 1-1/4 to 1-1/2 turns.
- Close the idle adjusting screw by hand. Do not overtighten.
- Then open it 1-1/4 to 1-1/2 turns.
- Start the engine and let it warm up.
- Set the throttle control to FAST. Adjust the high speed adjusting screw **in** until the engine speed or sound alters. Adjust the screw **out** until the engine speed sound alters. Note the difference between the two limits and set the screw in the middle of the range.
- Set the throttle control to SLOW. Adjust the idle adjusting screw **in** until the engine speed drops, then adjust the screw **out** until the engine speed drops. Note the difference between the two limits and set the screw in the middle of the range.
- If the engine tends to stall under load or not accelerate from low speed to high speed properly, adjust the high speed screw out in 1/8 turn increments until the problem is resolved.
- Let the engine run undisturbed for 30 seconds between each setting to allow the engine to react to the previous adjustments.

**IMPORTANT:** NEVER TAMPER WITH THE ENGINE GOVERNOR, WHICH IS FACTORY SET FOR PROPER ENGINE SPEED. OVERSPEEDING THE ENGINE ABOVE THE FACTORY HIGH SPEED SETTING CAN BE DANGEROUS. IF YOU THINK THE ENGINE - GOVERNED HIGH SPEED NEEDS ADJUSTING, CONTACT YOUR NEAREST SEARS SERVICE CENTER, WHICH HAS THE PROPER EQUIPMENT AND EXPERIENCE TO MAKE ANY NECESSARY ADJUSTMENTS.

## TO ADJUST OR REPLACE THE SPARK PLUG

If you have difficulty starting your snow thrower, you may need to adjust or replace the spark plug. Follow the instructions below.

Replace the spark plug if electrodes are pitted or burned or if the porcelain is cracked.

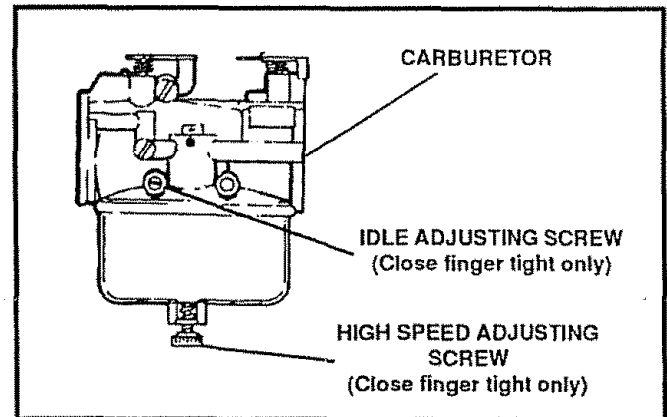

FIG. 40

### TO ADJUST:

- Clean the spark plug by carefully scraping electrodes (do not sand blast or use a wire brush).
- Be sure the spark plug is clean and free of foreign material. Check electrodes gap (See Fig. 41) with a wire feeler gauge and reset the gap to .030 inch if necessary.

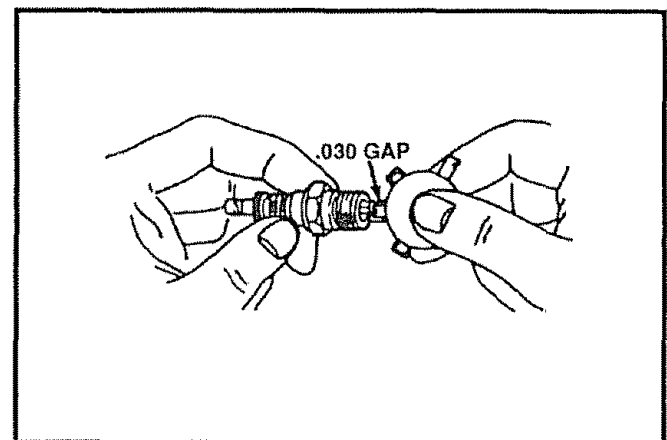

FIG. 41

### TO REPLACE:

- If you need a new spark plug, use only the proper replacement spark plug (See page 4).
- Set the gap to .030.
- Before installing the spark plug, coat its threads lightly with graphite grease to insure easy removal.
- Tighten the plug firmly into the engine.
- If a torque wrench is available, torque the plug to 18 to 23 ft - lbs.

# STORAGE



**CAUTION: NEVER STORE YOUR SNOW THROWER INDOORS OR IN AN ENCLOSED, POORLY VENTILATED AREA IF GASOLINE REMAINS IN THE TANK. FUMES MAY REACH AN OPEN FLAME, SPARK OR PILOT LIGHT FROM A FURNACE, WATER HEATER, CLOTHES DRYER, CIGARETTE, ETC.**

To prevent engine damage (if snow thrower is not used for more than 30 days) follow the steps below.

## ENGINE STORAGE

Gasoline must be removed or treated to prevent gum deposits from forming in the tank, filter, hose, and carburetor during storage. Also during storage, alcohol blended gasoline that uses ethanol or methanol (sometimes called gasohol) attracts water. It acts on the gasoline to form acids which damage the engine.

- To remove gasoline, run the engine until the tank is empty and the engine stops. Then drain remaining gasoline from carburetor by pressing upward on bowl drain located on the bottom of carburetor (See Figure 42).
- If you do not want to remove gasoline, a fuel stabilizer (such as Craftsman Fuel Stabilizer No. 33500) may be added to any gasoline left in the tank to minimize gum deposits and acids. If the tank is almost empty, mix stabilizer with fresh gasoline in a separate container and add some to the tank. **ALWAYS FOLLOW INSTRUCTIONS ON STABILIZER CONTAINER. THEN RUN ENGINE AT LEAST 10 MINUTES AFTER STABILIZER IS ADDED TO ALLOW MIXTURE TO REACH CARBURETOR. STORE SNOW THROWER IN A SAFE PLACE. SEE WARNING ABOVE.**

You can keep your engine in good operating condition during storage by:

- Changing oil.
- Lubricating the piston/cylinder area. This can be done by first removing the spark plug and squirting clean engine oil into the spark plug hole. Then cover the spark plug hole with a rag to absorb oil spray. Next, rotate the engine by pulling the starter two or three times. Finally, reinstall spark plug and attach spark plug wire.

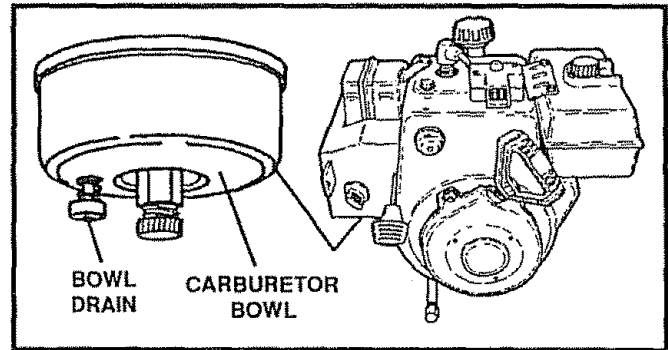

FIG. 42

## SNOW THROWER STORAGE

- Thoroughly clean the snow thrower.
- Lubricate all lubrication points (see the Maintenance section on pages 17-18).
- Be sure that all nuts, bolts and screws are securely fastened. Inspect all visible moving parts for damage, breakage and wear. Replace if necessary.
- Touch up all rusted or chipped paint surfaces; sand lightly before painting.
- Cover the bare metal parts of the blower housing auger and the impeller with rust preventative, such as sprayable lubricant.

**NOTE:** A yearly checkup or tuneup by a SEARS Service Center is a good way to insure that your snow thrower will provide maximum performance for the next season.

## OTHER

- If possible, store your snow thrower indoors and cover it to give protection from dust and dirt.
- If the machine must be stored outdoors, block up the snow thrower to be sure the entire machine is off the ground.
- Cover the snow thrower with a suitable protective cover that does not retain moisture. Do not use plastic.

**IMPORTANT:** NEVER COVER SNOW THROWER WHILE ENGINE AND EXHAUST AREAS ARE STILL WARM.

# SERVICE RECOMMENDATIONS

SERVICE RECORDS Fill in dates as you complete regular service	SCHEDULE							SERVICE DATES					
	After First 2 hours	Before Each Use	Often	Every 10 Hours	Every 25 Hours	First of Each Season	Before Storage						
Check Engine Oil Level		✓				✓							
Change Engine Oil	✓				✓	✓							
Tighten All Screws and Nuts	✓		✓										
Check Traction Clutch Cable Adjustment (See Cable Adjustment)						✓							
Replace Spark Plug					✓	✓							
Adjust Drive Belts	✓				✓	✓							
Lubricate All Pivot Points				✓			✓						
Lubricate Auger Shaft (See Shear Bolt Replacement)							✓						
Lubricate Sprockets and Chains Sparingly (Track Assembly)				✓			✓						
Drain Fuel							✓						
Check Auger Clutch Cable Adjustment (See Cable Adjustment)						✓							
Friction Wheel Zerk Fitting (See Maintenance)				✓									

## LUBRICATION CHART

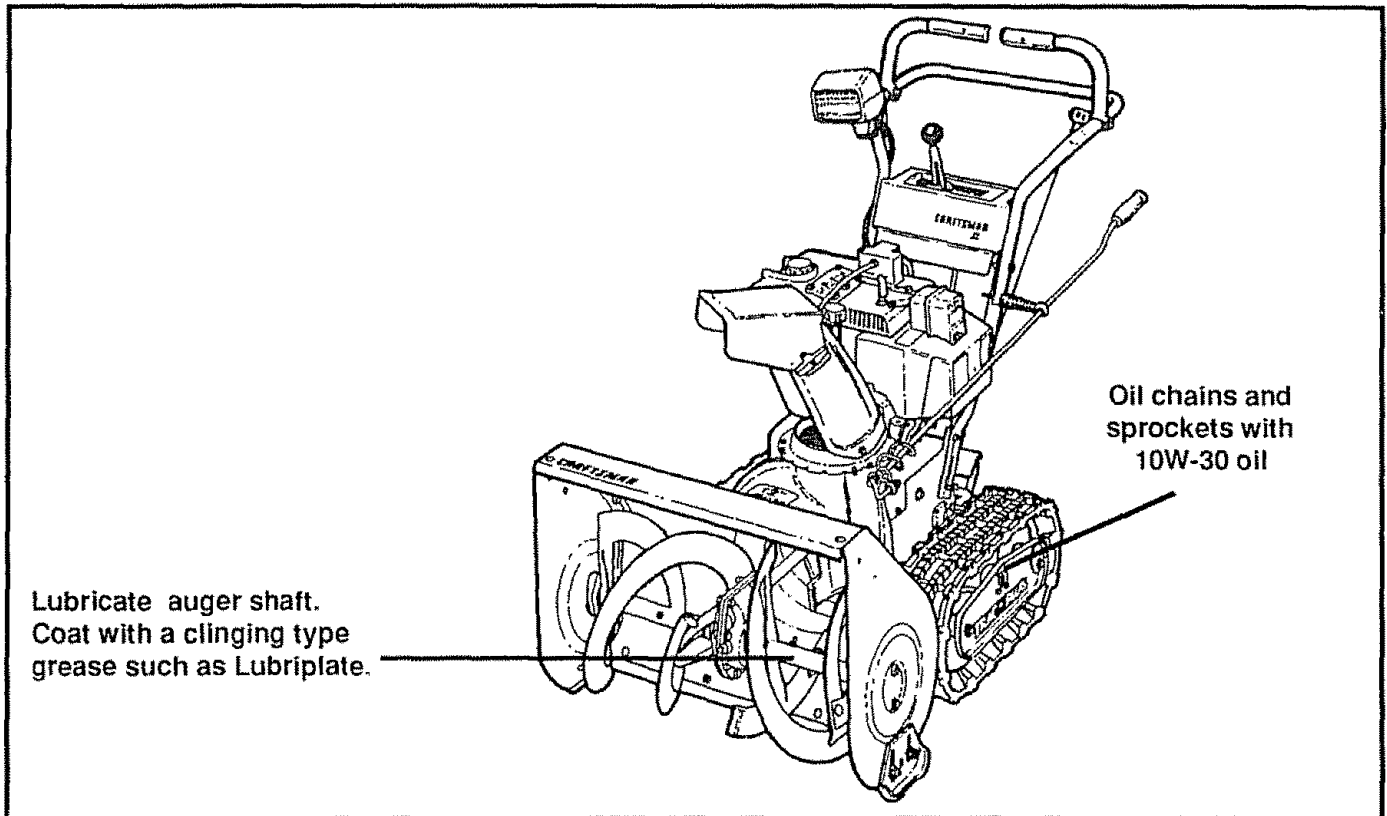

# TROUBLE SHOOTING POINTS

TROUBLE	CAUSE	CORRECTION
Difficult starting	Defective spark plug	Replace defective plug.
	Water or dirt in fuel system	Use carburetor bowl drain to flush and refill with fresh fuel.
Engine runs erratic	Blocked fuel line or low on fuel	Clean fuel line; check fuel supply; add fresh fuel (gasoline/oil mixture if 2 cycle engine).
Engine stalls	Unit running on CHOKE	Set choke lever to RUN position.
Engine runs erratic; Loss of power	Water or dirt in fuel system	Use carburetor bowl drain to flush and refill with fresh fuel.
	Carburetor out of adjustment	Adjust carburetor.
Excessive vibration	Loose parts; damaged impeller	Stop engine immediately and disconnect spark plug wire. Tighten all bolts and make all necessary repairs. If vibration continues, have the unit serviced by a competent repairman.
Unit fails to propel itself	Drive belt loose or damaged	Replace drive belt.
	Incorrect adjustment of traction drive cable	Adjust traction drive cable.
	Worn or damaged friction wheel	Replace friction wheel.
Unit fails to discharge snow	Auger drive belt loose or damaged	Adjust auger drive belt; replace if damaged.
	Auger control cable not adjusted correctly	Adjust auger control cable.
	Shear bolt broken	Replace shear bolt.
	Discharge chute clogged	Stop engine immediately and disconnect spark plug wire. Clean discharge chute and inside of auger housing.
	Foreign object lodged in auger	Stop engine immediately and disconnect spark plug wire. Remove object from auger.
Unit rides up	Weight transfer disengaged	Engage weight transfer pedal.

# NOTES

# CRAFTSMAN 32" TRAC-PLUS SNOW THROWER 536.885020

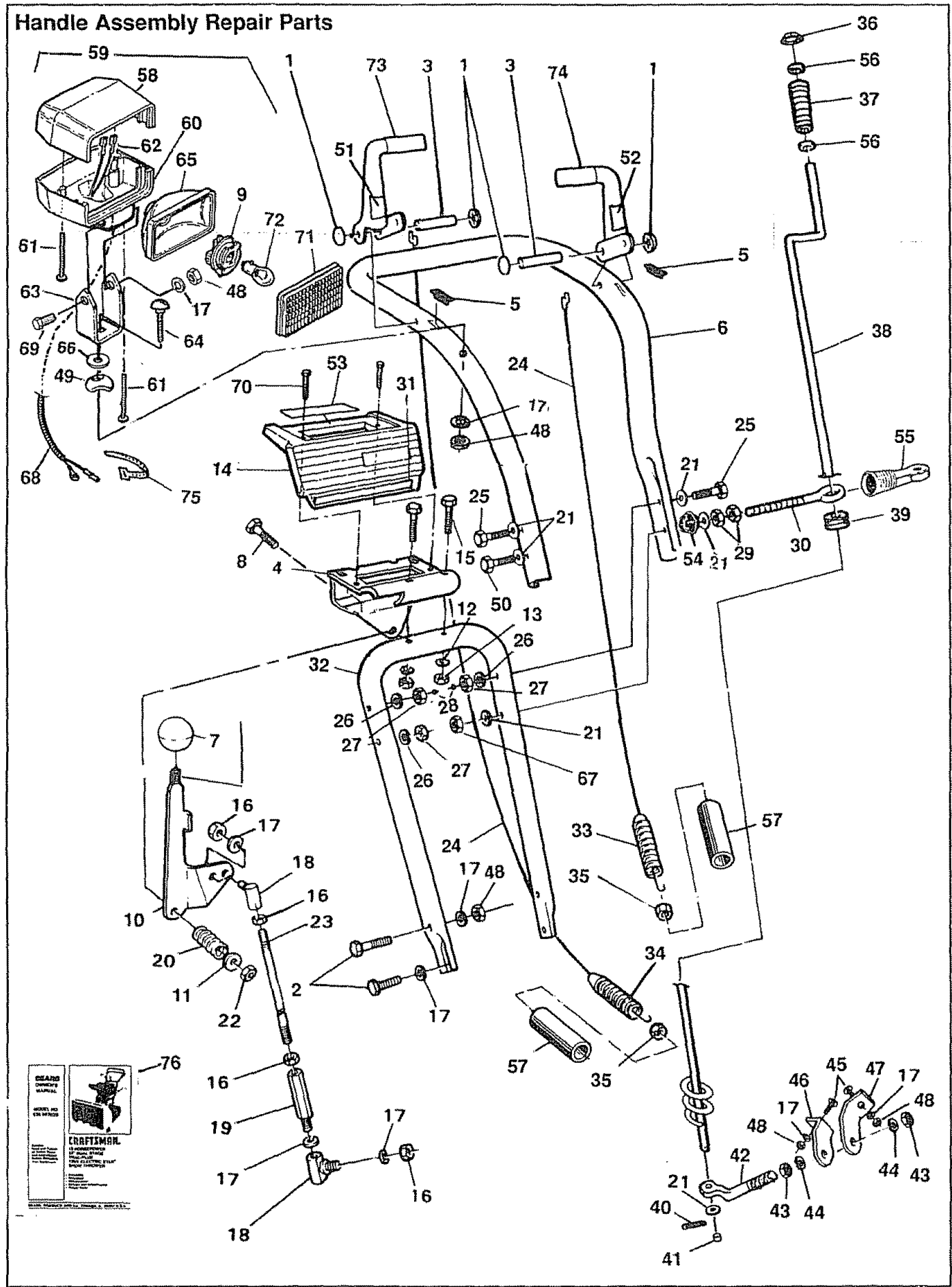

# CRAFTSMAN 32" TRAC-PLUS SNOW THROWER 536.885020

REF. NO.	PART NO.	PART NAME
1	3535	Cap, Push, 5/6 In.
2	70985	Screw, 5/16-18 x 3/4 In.
3	3538	Pivot Pin
4	310421	Support, Control Panel Assembly
5	4049	Bumper
6	308012	Upper Handle
7	53861	Control Knob
8	70990	Screw, 5/16-18 x 1-3/4 In.
9	309793	Socket, Headlight
10	308037	Shift Lever
11	71071	Flatwasher, 11/32 In.
12	71059	Lockwasher, 1/4 In.
13	71034	Hex Nut, 1/4-20
14	306523	Control Panel
15	310391	Carriage Bolt, 1/4-20 x 2 In.
16	71042	Hex Nut, 5/16-24
17	71060	Lockwasher, 5/16 In.
18	50782	Ball Joint
19	6352	Adaptor, Speed Control Rod
20	50786	Spring
21	71072	Flatwasher, 3/8 In.
22	71038	Locknut, Hex, 5/16-18
23	1668	Rod, Speed Control
24	1578	Clutch Cable
25	7288	Screw, 3/8-16 x 3 In.
26	71062	Lockwasher, Split, 3/8 In.
27	71044	Hex Nut, 3/8-16
28	7289	Plastic Stop, 3/8 In.
29	71045	Nut, Hex Jam, 3/8-16
30	71457	Eye Bolt, 3/8-16 x 5 In.
31	308789	Decal, Control Panel
32	307913	Lower Handle
33	1671	Spring, Drive Clutch
34	1673	Spring, Auger Clutch
35	71035	Locknut, 1/4-20
36	304872	Retainer Ring
37	307399	Handle, Chute Crank
38	85192	Crank Assembly
39	148	Grommet, Eye Bolt
40	71081	Cotter Pin, 3/32 x 3/4 In.

REF. NO.	PART NO.	PART NAME
41	104	Plastic Cap
42	7055	Rod, Chute Control
43	7058	Jam Nut, 1/2-20
44	7059	Lockwasher, Split, 1/2 In.
45	70993	Carriage Bolt, 5/16-18 x 3/4 In.
46	7052	Bracket, Chute Rotate L. H.
47	7053	Bracket, Chute Rotate R. H.
48	71037	Hex Nut, 5/16-18
49	580527	Saddlewasher, 5/16 In.
50	71007	Hex Head Bolt, 3/8-16 x 2 In.
51	3903	Auger Drive Control Decal
52	3902	Traction Drive Control Decal
53	6300	Gear Selector Decal
54	309344	Adaptor For Boot
55	308145	Eyeboll Boot
56	309312	Flatwasher, 3/8 In.
57	308146	Clutch Spring Boot
58	307395	Upper Housing, Headlight
59	305025	Headlight Assembly
60	580530	Lower Housing, Headlight
61	307781	Screw, #10 x 1-3/4 In.
62	307767	Wiring Harness
63	580532	Bracket, Headlight Mounting
64	4160	Bolt, Carriage, 5/16-18 x 1-3/4 In.
65	309792	Metalized Back
66	71061	Washer, External Lock
67	71046	Locknut, Nylon, 3/8-16
68	6636	Conduit, Plastic
69	235	Screw Hex Head, 5/16-18 x 2 In.
70	308909	Screw, 10-24 x 5/8 In.
71	309789	Lens, Headlight
72	309791	Bulb, Headlight
73	307918	Auger Drive Lever
74	307920	Traction Drive Lever
75	57444	Cable Tie
76	307251	Owner's Manual

# CRAFTSMAN 32" TRAC-PLUS SNOW THROWER 536.885020

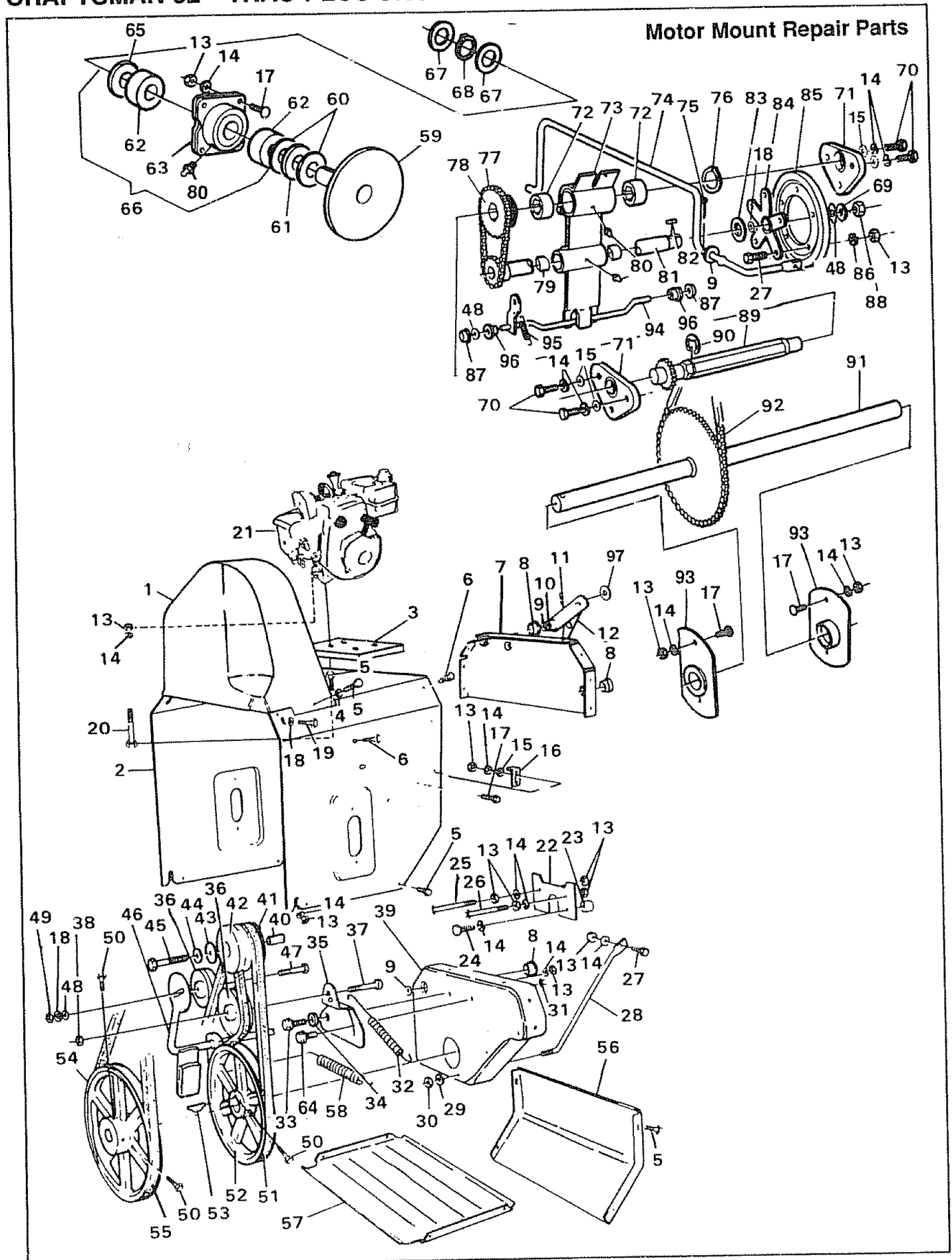



# CRAFTSMAN 32" TRAC-PLUS SNOW THROWER 536.885020

REF. NO.	PART NO.	PART NAME
1	307923	Belt Cover
2	5507	Motor Mount Frame
3	307968	Engine Riser
4	71067	Flatwasher, 1/4 In.
5	70978	Screw, Self-Tap, 1/4-20 x 1/2 In.
6	70982	Screw, Self-Tap, 5/16-18 x 1/2 In.
7	5513	End Plate
8	53703	Flanged Bearing
9	71074	Flatwasher, 1/2 In.
10	73801	Roll Pin, 5/32 x 7/8 In.
11	85492	Lever, Auger Clutch
12	85494	Lever, Clutch Cable
13	71037	Hex Nut, 5/16-18
14	71060	Lockwasher, 5/16 In.
15	71071	Flatwasher, 5/16 In.
16	53713	Bracket, Clutch Adjustment
17	70993	Carriage Bolt, 5/16-18 x 3/4 In.
18	71062	Lockwasher, 3/8 In.
19	71012	Screw, Self-Tap, 3/8-16 x 1 In.
20	8220	Bolt, 5/16-18 x 2-1/2 In.
21	307964	Engine, Craftsman, Model No. 143.816012 (See Engine Repair Parts List)
22	85187	Belt Guard Plate
23	51438	Spacer
24	71393	Bolt, 5/16-24 x 1 In.
25	70991	Bolt, 5/16-18 x 3 In.
26	71362	Bolt, 5/16-18 x 2-3/4 In.
27	70985	Bolt, 5/16-18 x 3/4 In.
28	51445	Rod, Spindle Support
29	71059	Lockwasher, 1/4 In.
30	71034	1/4-20 Hex Nut
31	71391	Nut, 5/16-18
32	51477	Spring, Drive Idler
33	50740	Shoulder Bolt, 5/16-18
34	71073	Flatwasher, 7/16 In.
35	1110	Idler Drive Belt Bracket
36	51448	Idler Pulley, 3 In.
37	71006	Bolt, 3/8-16 x 1-1/4 In.
38	590	Nut, Jam, 3/8-16
39	53696	Spindle Plate
40	50747	Engine Pulley Spacer
41	53720	Pulley, Traction Drive
42	53721	Pulley, Auger Drive
43	50677	Washer
44	71063	Lockwasher, 3/8 In.
45	71128	Bolt, 3/8-24 x 1-1/4 In.
46	169	Auger Clutch Rod Assembly
47	71010	Bolt, 3/8-16 x 1-1/2 In.
48	71072	Flatwasher, 3/8 In.

REF. NO.	PART NO.	PART NAME
49	71045	Jam Nut, 3/8-16
50	130	Screw, 5/16-18 x 3/4 In.
51	51458	Belt, Traction Drive, Special
52	50794	Traction Pulley
53	20556	Square Key
54	50796	Auger Pulley 8.4 In.
55	51224	Belt, Auger Drive, Special
56	307951	Rear Panel
57	304129	Bottom Panel
58	4293	Spring, Auger Brake
59	85214	Friction Disc Assembly
60	50683	Flatwasher
61	50684	Bearing, Roller
62	50689	Needle Bearing
63	50690	Housing, Blade Shaft
64	70984	Screw, Self-Tap, 5/16-18 x 3/4 In.
65	50654	Seal, Oil
66	85095	Housing, Disc Drive
67	50666	Flatwasher
68	50688	Ring Retainer, 3/4 In.
69	4051	Spring Washer
70	3134	Screw, 5/16-18 x 1/2 In.
71	1413	Bearing and Retainer Assembly
72	50705	Drive Shaft Bearing
73	85204	Clutch Plate
74	51446	Yoke, Speed
75	71081	Cotter Pin, 3/32 x 3/4 In.
76	50707	Retainer
77	50798	Chain
78	50706	Drive Sprocket
79	50700	Bearing, Clutch
80	30440	Grease Fitting
81	6550	Shaft & Gear Assembly
82	71203	Key, 1/8 In.
83	50704	Washer
84	5892	Hub, Friction Wheel
85	5898	Friction Wheel
86	71061	Lockwasher, Ext, Tooth, 5/16 In.
87	1795	Cap Retainer, 3/8 In.
88	71048	Hex Nut, 3/8-24
89	4062	Hex Shaft
90	50884	Retainer
91	6177	Axle
92	50797	Chain
93	5954	Bearing and Plate
94	85421	Yoke, Drive
95	53710	Spring, Clutch Yoke Return
96	50712	Bushing
97	73795	Flatwasher

# CRAFTSMAN 32" TRAC-PLUS SNOW THROWER 536.885020

## Track Assembly Repair Parts

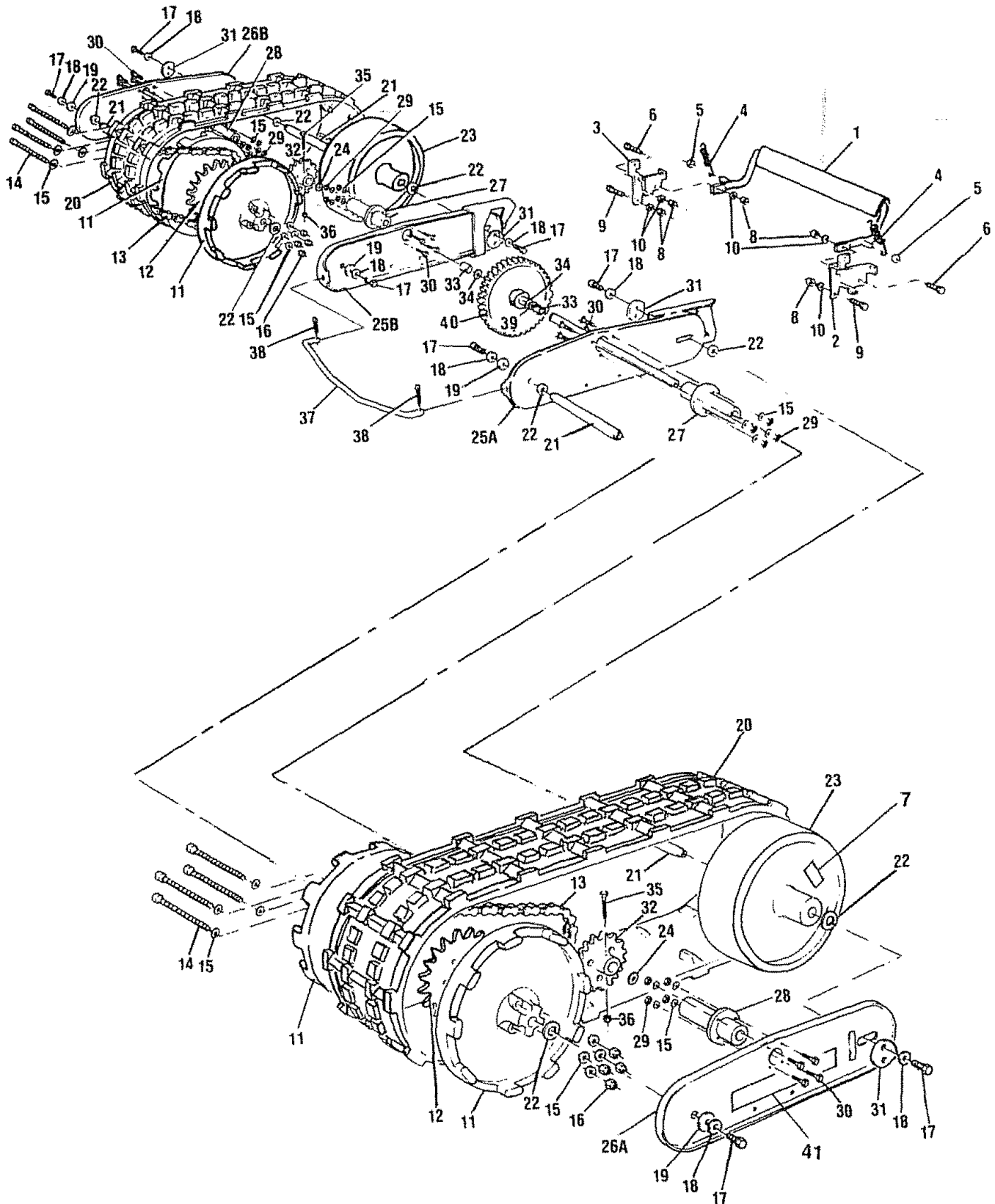

# CRAFTSMAN 32" TRAC-PLUS SNOW THROWER 536.885020

REF. NO.	PART NO.	PART NAME	REF. NO.	PART NO.	PART NAME
1	308161	Foot Pedal Assembly	23	7087	Idler Wheel
2	10900	Bracket, L.H.	24	305299	Flatwasher, 3/4 In.
3	10901	Bracket, R.H.	25A	308914	Track Plate, Inner L.H.
4	6025	Spring, Tension	25B	308915	Track Plate, Inner R.H.
5	518	Pal Nut, 1/2"	26A	308034	Track Plate, Outer L.H.
6	6001	Shoulder Bolt, 5/16-18	26B	308036	Track Plate, Outer R.H.
7	6888	Light Blue Decal	27	7048	Hub - Inner Bearing
8	71037	Hex Nut, 5/16-18	28	7049	Hub - Outer Bearing
9	70985	Screw, 5/16-18 x 3/4 In.	29	71035	Locknut, 1/4-20
10	71060	Lockwasher, 5/16 In.	30	70969	Bolt, 1/4-20 x 1 In.
11	7089	Wheel, Track Drive	31	6403	Cam Washer
12	5927	Sprocket Plate	32	304133	Hub Sprocket Assembly
13	5916	Chain	33	7106	Spacer
14	5947	Screw, 1/4-28 x 3-3/4 In.	34	73840	Flatwasher
15	71067	Flatwasher, 1/4 In.	35	7285	Screw, 1/4-20 x 1-1/2 In.
16	6108	Locknut, 1/4-28	36	73826	Locknut, 1/4-20
17	71348	Screw, 5/16-18 x 1/2 In.	37	6049	Connecting Rod
18	5951	Bell Washer	38	20465	Hair Pin
19	5950	Washer	39	239	Retaining Ring
20	5949	Track	40	6177	Axle & Sprocket Assembly
21	7086	Shaft, Track Wheel	41	308784	Trac-Plus Decal
22	7074	Hardened Washer, 1/2 In.			

# CRAFTSMAN 32" TRAC-PLUS SNOW THROWER 536.885020

## Auger Housing Assembly Repair Parts

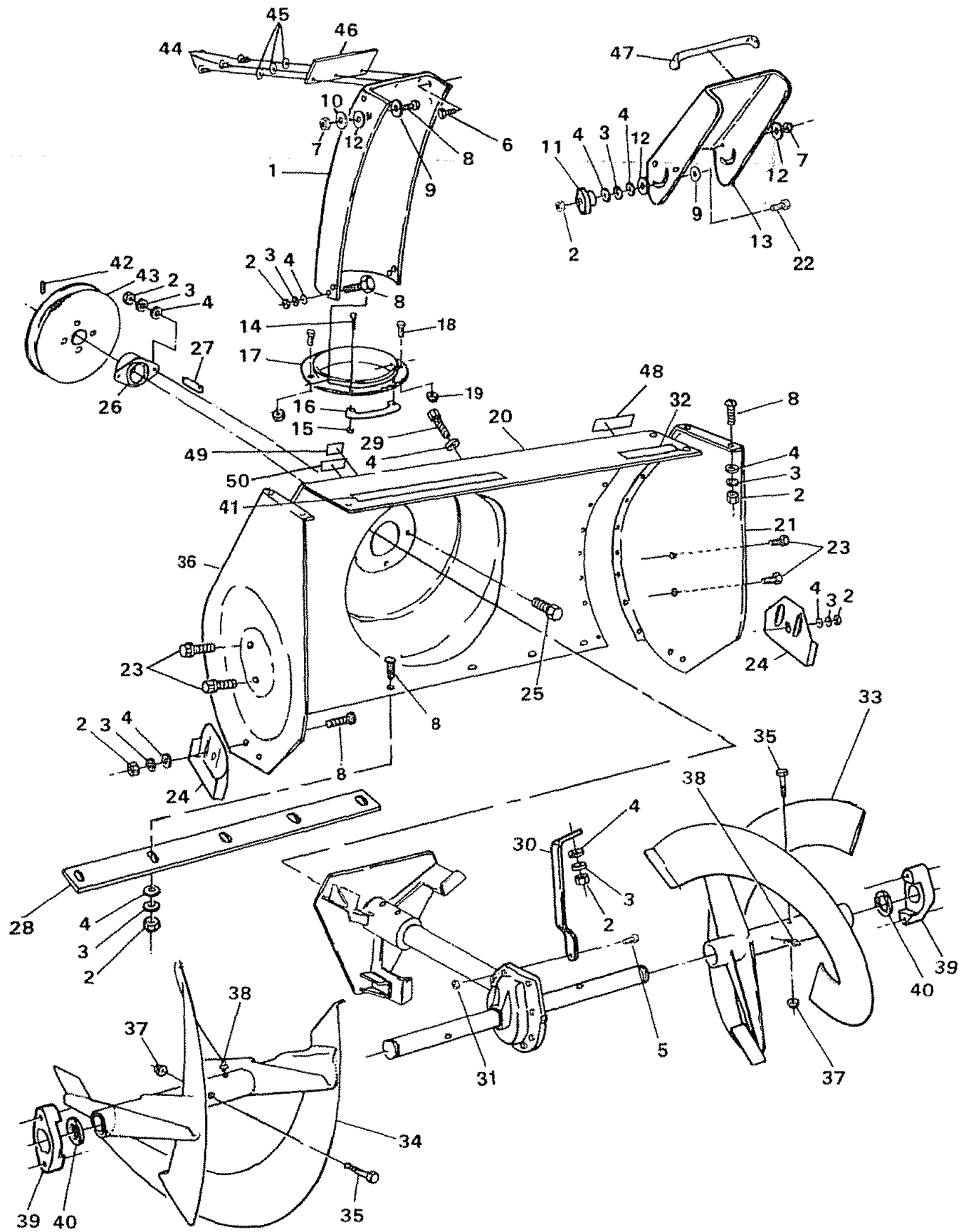

# CRAFTSMAN 32" TRAC-PLUS SNOW THROWER 536.885020

REF. NO.	PART NO.	PART NAME	REF. NO.	PART NO.	PART NAME
1	307921	Chute Extension	26	308059	Bearing, 7/8 In.
2	71037	Hex Nut, 5/16-18	27	20556	Square Key
3	71060	Lockwasher, 5/16 In.	28	85104	32" Scraper Bar
4	71071	Flatwasher, 11/32"	29	70986	Bolt, 5/16-18 x 1 In.
5	1441	Screw, 5/16-24 x 1-3/4 In.	30	308860	Gear Box Brace
6	71147	Pan Head Slotted Bolt, 5/16-18 x 3/4 In.	31	71100	Nut, 5/16-24
7	71038	Locknut, 5/16-18	32	308790	Size Decal
8	70993	Carriage Bolt, 5/16-18 x 3/4 IN	33	307911	32 In. Auger, L.H.
9	71073	Flatwasher, 7/16 In.	34	307910	32 In. Auger, R.H.
10	71072	Flatwasher, 3/8 In.	35	578647	Bolt, 5/16-18 x 2 In.
11	57171	Wing Knob	36	308121	Side Plate, R.H.
12	6711	Plastic Washer	37	71391	Locknut, 5/16-18
13	307725	Chute Deflector	38	10104	Grease Fitting
14	71032	Screw, #8-32 x 1/2 In.	39	53757	Bearing, Auger Shaft
15	71058	Locknut, #8-32	40	50748	Washer
16	85113	Retainer Ring	41	308766	Name Decal
17	309321	Flange, Chute Ring	42	130	Screw, 5/16-18 x 3/4 In.
18	70969	Screw, 1/4-20 x 1 In.	43	50796	Auger Pulley 8.4 In.
19	71035	Locknut, 1/4-20	44	3362	Rivet, 3/16 In.
20	5500	Auger Housing 32 In.	45	71076	Flatwasher, 3/16 In.
21	308120	Side Plate, L. H.	46	3194	Skirt
22	3316	Bolt, 5/16-18 x 1 In.	47	7679	Chute, Striped Danger Decal
23	70984	Screw, Self-Tap, 5/16-18 x 3/4 In.	48	70141	Auger, Danger Decal
24	307912	Height Adjustor Skid	49	7376	Impeller, Danger Decal
25	70983	Screw, 5/16-18 x 5/8 In.	50	70142	Chute, Danger Decal

# CRAFTSMAN 32" TRAC-PLUS SNOW THROWER 536.885020

## Gear Box Repair Parts

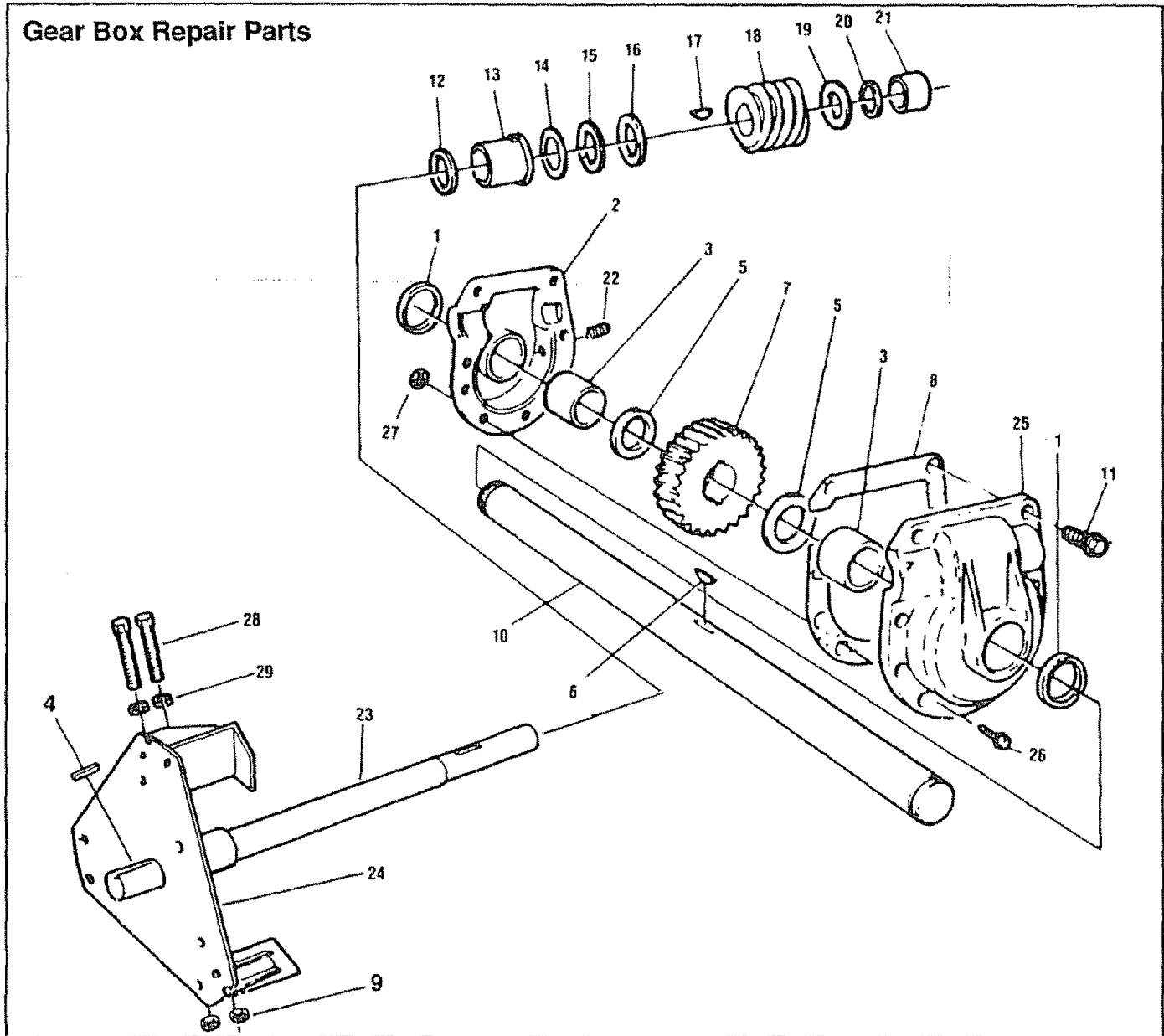

REF. NO.	PART NO.	PART NAME
1	1065	Seal
2	895	Housing L.H.
3	53743	Bearing, Auger Gear Box
4	20556	Square Key
5	53748	Flatwasher, 1"
6	73905	Woodruff #91 Key
7	53730	Worm Gear
8	897	Gasket, Gear Box
9	73826	Locknut, 1/4-20
10	1403	32" Auger Shaft
11	1441	Screw, 5/16-24 x 1-3/4"
12	53737	Ring Quad
13	53736	Bearing, Impeller Shaft
14	53735	Flatwasher, 7/8"
15	53734	Bearing, Roller

REF. NO.	PART NO.	PART NAME
16	53733	Flatwasher, 7/8"
17	50795	Key, Hi-Pro 606
18	53732	Worm Gear
19	50683	Flatwasher
20	50688	Ring Retainer
21	53731	Bearing, Impeller Shaft
22	53749	Grease Plug
23	1401	Shaft, Gear Box Input
24	307909	Impeller
25	896	Housing, R.H.
26	71393	Screw, 5/16-24 x 1"
27	71100	Flange Locknut, 5/16-24
28	73839	Screw, 1/4-20 x 2-1/4"
29	71067	Flatwasher, 1/4"

REWIND STARTER NO. 590630

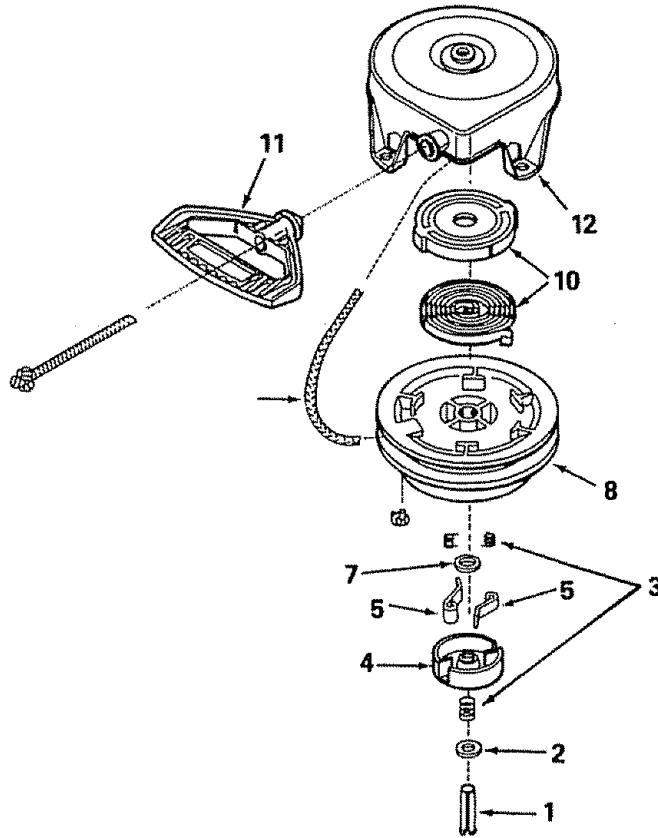

Ref. No.	Part No.	Part Name
	590630	Starter, Rewind
1	590599A	Pin, Spring (Incl. No. 7)
2	590600	Washer
3	590651	Spring Assy., Brake & Dog
4	590627	Retainer
5	590641	Dog, Starter
7	590601	Washer
8	590628	Pulley
9	590451A	Rope, Starter
10	590629	Spring & Keeper Assy.
11	590574	Handle, Mitten Grip (Not included with starter)
12	590631	Housing Assy., Starter

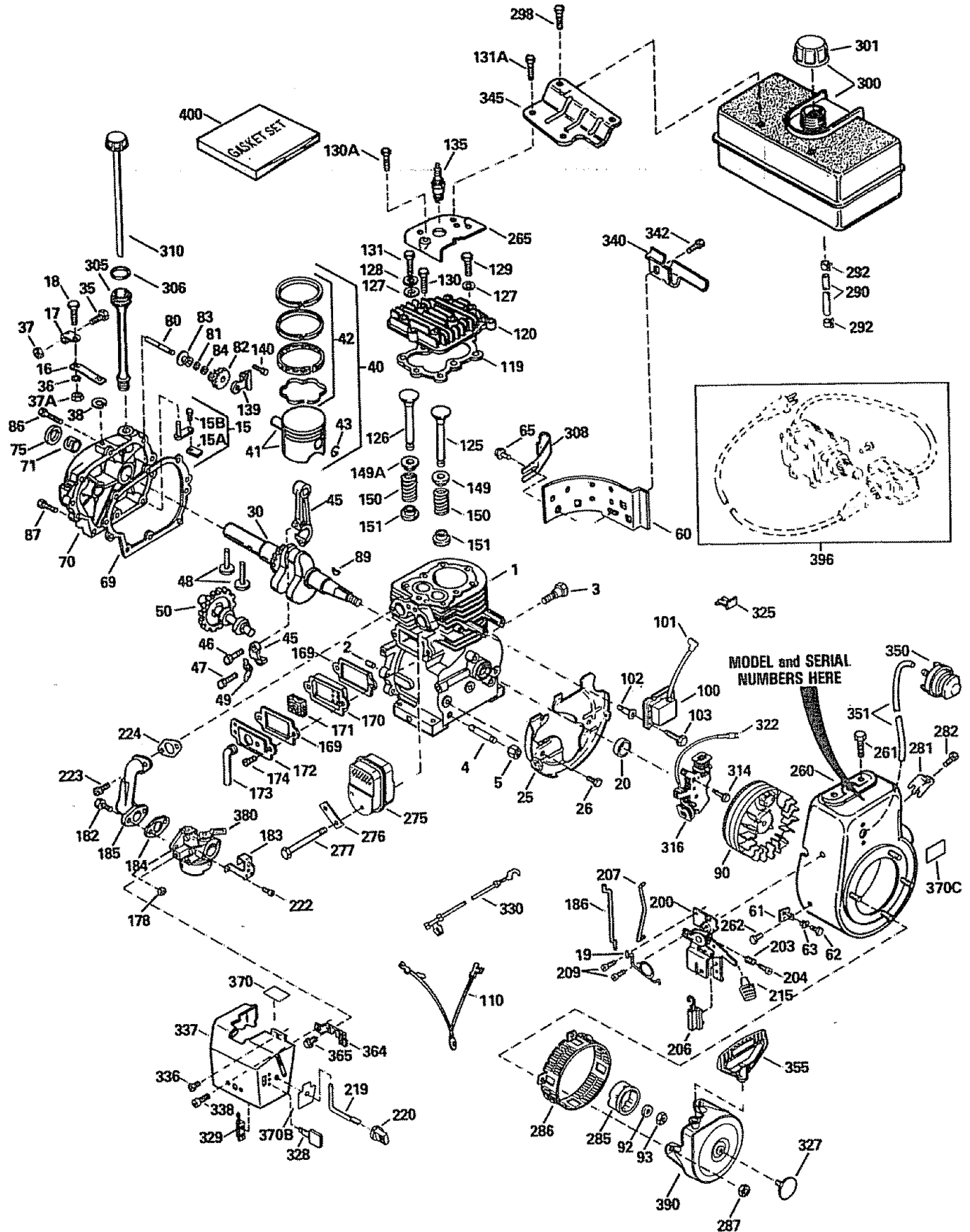



# CRAFTSMAN 4-CYCLE ENGINE

MODEL:143.816012

Ref. No.	Part No.	Part Name	Ref. No.	Part No.	Part Name
1	35371	Cylinder (Incl. Nos. 3, 4 & 5)	66	27880A	Valve, Exhaust (Incl. No. 70) (1/32" oversize)
2	650820	Screw, Hex hd. shoulder, 1/4-20 x 1/2			Valve, Intake (Incl. No. 70) (Std.)
3A	34171	Nipple, Pipe, 5-1/2"	67	34035	Valve, Intake (Incl. No. 70) (1/32" oversize)
3B	30969	Cap, Oil drain	67	34036	Valve, Intake (Incl. No. 70) (1/32" oversize)
4	35319	Seal, Oil			Cap, Upper valve spring
5	27652	Pin, Dowel	68	27882	Seal Assy., Intake valve
6	35326	Baffle, Blower housing	68A	34689	Spring, Valve
7	650561	Screw, Hex washer hd. Durlok, 1/4-20 x 5/8	69	27881	Cap, Lower valve spring
			70	32581	Key, Flywheel
8	35443	Crankshaft	76	32589	Clip, Spring
9	34860A	Piston, Pin & Ring Assy. (Incl. Nos. 9A, 10 & 11) (std.)	77	29443	Flywheel (w/ring gear)
			78	611093	Washer, Lock
9	34861	Piston, Pin & Ring Assy. (Incl. Nos. 9A, 10 & 11) (.010 oversize)	79	650880	Nut, Flywheel
			80	650881	Stud, Solid state mounting
9	34862	Piston, Pin & Ring Assy. (Incl. Nos. 9A, 10 & 11) (.020 oversize)	81	650872	Solid, State Assy.
			82	35135	Cover, Spark plug
9A	34863	Piston & Pin Assy. (Incl. No. 10) (Std.)	82A	610118	Screw, Torx Hex washer hd. Sems, 10-24 x 1
9A	34864	Piston & Pin Assy. (Incl. No. 10) (.010 oversize)	83	650814	Screw, Hex hd. Sems, 1/4-20 x 3/4
					Coil Assy., Alternator (18 Watt)
9A	34865	Piston & Pin Assy. (Incl. No. 10) (.020 oversize)	85	650873	Wire, Ground
			86	611111	Gasket, Cylinder head
10	27888	Ring, Piston pin retaining	95	35253	Head, Cylinder
11	34866A	Ring Set, Piston (Std.)	96	34923A	Screw, Hex flange hd., 5/16-18 x 1-1/2
11	34867	Ring Set, Piston (.010 oversize)	97	34030	Spark Plug (Champion J-8C or equivalent)
11	34868	Ring Set, Piston (.020 oversize)	98	6021A	Washer, Flat
17	35373A	Rod Assy., Connecting (Incl. Nos. 18, 19 & 19A)	99	33636	Screw, Special hex hd. tapped, 5/16-18 x 1-3/4
18	35374	Dipper, Oil	100	650691	Washer, Belleville
19	650908	Bolt, Connecting rod	101	650727	Screw, Hex flange hd., 5/16-18 x 2
19A	650882	Bolt, Connecting rod			Gasket, Breather
20	34034	Lifter, Valve	102	650690	Body, Breather
21	35375	Camshaft (Mechanical Compression Release)	103	650694A	Element, Breather
			104	*27896A	Cover, Breather
22	33273A	Extension, Blower housing	105	28423	Tube, Breather
23	650128	Screw, Hex hd. Sems, 10-24 x 1/2	106	28424	Screw, Hex hd. Sems, 10-24 x 1/2
24	*35262	Gasket, Cylinder cover	107	28425	Nut & Lockwasher, 1/4-2B
25	35376	Cover Assy., Cylinder (Incl. Nos. 26, 27 & 37)	108	35350	Gasket, Carburetor
			109	650128	Pipe, Intake
26	35377	Bushing, Cylinder cover	114	29752	Screw, Fil. hd. Sems, 1/4-28 x 1
27	35319	Seal, Oil	115	*33263	Screw, Torx fil. hd. Sems, 5/16-18 x 1-1/8
33	30699C	Rod Assy., Governor (Incl. Nos. 34 & 35)	117	33877	Gasket, Intake pipe
			118	30088A	Bracket, Choke
34	30700	Yoke, Governor	119	650378	Screw, Fil. hd. Sems, 10-32 x 1/2
35	650494	Screw, Fil. hd. Sems, 6-40 x 5/16			Bracket, Carburetor cover mounting
36	29642	Ring, Retaining	120	*27915A	Screw, Hex washer hd. Sems, taptite, 8-36 x 5/8
37	31845	Shaft, Governor	121	34587	Housing, Blower
38	30588A	Spool, Governor	122	28820	Primer Assy.
39	35479	Washer, Flat	123	33377	Line, Primer
40	29193	Ring, Retaining	124	650767	Bracket Assy., Control (Incl. Nos. 134, 135, 136 & 138)
41	35378	Gear, Governor (Incl. No. 39)			Spring, Compression
42	33369	Bracket, Governor gear	130	35447	Screw, Fil. hd., 5-40 x 7/16
43	650836	Screw, Hex washer hd. thread forming, 10-24 x 1/2	131	570682	Terminal Assy.
			132	32180C	Screw, Hex washer hd. thread cutting, 10-32 x 1/2
49	29916	Clamp, Governor lever	133	34677	Spring, Speed control
50	29826	Screw, Hex washer hd., 10-32 x 3/4			Link, Governor
51	29216	Locknut, Hex "Keps", 10-32	134	31342	Link, Governor-to-throttle
52	33454	Lever, Governor	135	650549	
53	29918	Washer, E.T. Lock	136	610973	
54	650548	Screw, Hex washer hd., 8-32 x 5/16	137	650821	
55	30322	Locknut, Hex "Keps", 8-32			
56	650832	Screw, Hex washer hd. Powerlok, 1/4-20 x 1-11/16	138	34663	
			139	34667	
57	650833	Screw, Hex washer hd. Powerlok, 1/4-20 x 1-3/16	140	33878	
58	35555	Dipstick, Oil			
59	35499	"O" Ring			
60	35554	Tube, Oil fill			
62	35540	Clip, Fill tube			
66	27878A	Valve, Exhaust (Incl. No. 70) (Std.)			

\*Indicates Parts Included in Gasket Set, Ref. No. 215.

# CRAFTSMAN 4-CYCLE ENGINE

MODEL:143.816012

Ref. No.	Part No.	Part Name	Ref. No.	Part No.	Part Name
281	33013	Cover, Starter hole	340	34155	Bracket, Fuel tank
282	650760	Screw, Pan hd. taptite, 8-32 x 3/8	342	650561	Screw, Hex washer hd. Durllok, 1/4-20 x 5/8
285	35287	Hub, Starter	345	34154	Plate, Fuel tank mounting
286	35446	Screen, Starter	350	570682	Primer Assy.
287	29752	Nut & Lockwasher, 1/4-28	351	32180C	Line, Primer
290	30705	Line, Fuel	355	590574	Starter Handle, Mitten grip
292	26460	Clamp, Fuel line	364	33377	Bracket, Carburetor cover mounting
298	650665	Screw, Hex washer hd. thread cutting, 1/4-15 x 7/8	365	650767	Screw, Hex washer hd. Sems, taptite, 8-32 x 27/64
300	34156A	Tank, Fuel (Incl. Nos. 292 & 301)	370	35878	Decal, Instruction
301	35355	Cap, Fuel tank	370B	35077	Decal, Choke
305	35554	Tube, Oil fill	370C	34144	Decal, Primer
306	35499	"O" Ring	380	632370A	Carburetor (Incl. No. 224)
308	35540	Clip, Fill tube	390	590630	Starter, Rewind
310	35555	Dipstick, Oil	396		Electric Starter Kit No. 143.88924 (Optional) Order as Accessory.
314	650873	Screw, Hex hd. Sems, 1/4-20 x 3/4	400	33279G	Gasket Set (Incl. items marked *)
316	611111	Coil Assy., Alternator (18 Watt)			RPM Settings: High Speed: 3550 - 3850 Low Speed: 1700
322	611118	Body Connector			*Indicates Parts Included in Gasket Set, Ref. No. 400.
325	29443	Clip, Spring			
327	35392A	Plug, Starter			
328	35593	Key, Ignition			
329	610973	Terminal Assy.			
330	35305	Wire, Ground			
336	650765	Screw, Hex washer hd. self-drilling, 10-32 x 1/2			
337	35057A	Cover, Carburetor			
338	28942	Screw, Hex washer hd. Sems, 10-32 x 3/8			

## CARBURETOR NO. 632370A

Ref. No.	Part No.	Part Name
	632370A	Carburetor
1	631776A	Shaft & Lever Assy., Throttle
2	631970	Spring, Throttle return
3	631778	Shutter, Throttle
4	650506	Screw, Throttle & Choke shutter
5	630766	Spring, Regulating screw
5A	630738	Spring, Main adjustment screw
6	650417	Screw, Idle regulating
7	632112	Shaft & Lever Assy., Choke
8	630735	Spring, Choke positioning
9	632174	Shutter, Choke
10	*630748	Plug, Welch
11	*631027	Plug, Welch
12	*631021	Inlet Needle, Seat & Clip Assy. (Incl. No. 13)
13	631022	Clip, Inlet needle
14	632019	Float, Carburetor
15	*631024	Shaft, Float
16	631951	Bowl, Float (Incl. Nos. 17 & 18)
17	27136A	Plunger Assy., Drain (Incl. No. 18)
18	27554	Gasket, Drain
20	*632239	Adjustment Screw Assy., Main (Incl. Nos. 5A, 21, 23 & 27)
21	27110	Gasket, Bowl-to-body
23	*630740	"O" Ring, Adjustment screw
24	632281	Screw, Idle adjustment
25	*631028	Gasket, Bowl-to-body
26	632164	Fitting, Fuel inlet
27	630739	Washer
28	632347	Repair Kit (Incl. items marked *)

# NOTES

# SEARS

## OWNER'S MANUAL

**MODEL NO.  
536.885020**

## HOW TO ORDER REPAIR PARTS

# CRAFTSMAN®

## 10 HORSEPOWER 32" DUAL STAGE TRAC-PLUS 120V. ELECTRIC START SNOW THROWER

Each SNOW THROWER has its own MODEL NUMBER found on the motor mount frame.

Each ENGINE has its own MODEL NUMBER found on the BLOWER HOUSING.

Always mention these MODEL NUMBERS when requesting service or Repair Parts for your SNOW THROWER.

All parts listed herein may be ordered through any Sears Service Center/Departments and most Sears Stores.

### WHEN ORDERING REPAIR PARTS, ALWAYS GIVE THE FOLLOWING INFORMATION:

- \* PRODUCT - "SNOW THROWER"
- \* MODEL NUMBER - 536.885020
- \* ENGINE MODEL NUMBER 143.816012
- \* PART NUMBER
- \* PART DESCRIPTION

"Your Sears merchandise has added value when you consider that Sears has service units nationwide staffed with Sears trained technicians...Professional technicians specifically trained on Sears Products, having the parts, tools and equipment to insure that we meet our pledge to you...we service what we sell."

SEARS, ROEBUCK AND CO., Chicago, IL 60684

307251 08/27/90

Printed in U.S.A.

## Free Manuals Download Website

<http://myh66.com>

<http://usermanuals.us>

<http://www.somanuals.com>

<http://www.4manuals.cc>

<http://www.manual-lib.com>

<http://www.404manual.com>

<http://www.luxmanual.com>

<http://aubethermostatmanual.com>

Golf course search by state

<http://golfingnear.com>

Email search by domain

<http://emailbydomain.com>

Auto manuals search

<http://auto.somanuals.com>

TV manuals search

<http://tv.somanuals.com>