



FCC Compliance Statement

This device complies with part 15 and part 18 of the FCC rules. Operation is subject to the following two conditions: (1) This device must not cause harmful interference, and (2) This device must accept any interference received, including interference that may cause undesired operation.

Further Inquiries

If you cannot locate specific information or have questions after reviewing this guide, please take advantage of Crestron's award winning customer service team by calling Crestron at 1-888-CRESTRON [1-888-273-7876]. You can also log onto the online help section of the Crestron website (www.crestron.com/onlinehelp) to ask questions about Crestron products. First-time users will need to establish a user account to fully benefit from all available features.

Future Updates

As Crestron improves functions, adds new features and extends the capabilities of the GLS-LCL units, additional information may be made available as manual updates. These updates are solely electronic and serve as intermediary supplements prior to the release of a complete technical documentation revision. Check the Crestron website periodically for manual update availability and its relevance. Updates are identified as an "Addendum" in the Download column.

Crestron Electronics, Inc.
15 Volvo Drive Rockleigh, NJ 07647
Tel: 888.CRESTRON
Fax: 201.767.7576
www.crestron.com

Operations & Installation Guide-DOC. 6773A
(2023020)
12.08
Specifications subject to
change without notice.

WARNINGS, CAUTIONS & NOTES

WARNING: To avoid fire, shock, or death; turn off power at circuit breaker or fuse and test that power is off before wiring!

CAUTION: Insufficient power can lead to unpredictable results or damage to the equipment. Please use the Crestron Power Calculator to help calculate how much power is needed for the system. (www.crestron.com/calculators).

NOTES: Observe the following points regarding sensor installation.

- To be installed and/or used in accordance with appropriate electrical codes and regulations.
- If you are unsure about any part of these instructions, consult a qualified electrician.

NETWORK WIRING

When wiring the Cresnet® network, consider the following:

- Use Crestron Certified Wire.
- Use Crestron power supplies for Crestron equipment.
- Provide sufficient power to the system.

PREPARING AND CONNECTING WIRES

Strip the ends of the wires approximately 1/2". Use care to avoid nicking the conductors. Twist together the ends of the wires that share a connection and tin the twisted connection. Apply solder only to the ends of the twisted wires. Avoid tinning too far up the wires or the end becomes brittle.

DESCRIPTION

The GLS-LCL Closed-Loop Photocell responds to ambient light levels within an occupied space and provides an analog voltage proportionate to the ambient light level.

The ambient light measured is the light from any light source in the visible spectrum. The photocell does not distinguish between natural sunlight and artificial light. It contains a sensor which is color and spatially corrected to provide a true representation of changes in lighting levels that the human eye perceives.

The sensor measures the ambient light that actually falls upon it within a 60° cone extending downward from the sensor (refer to "Field of View" illustration on the second page). This is the light that gets reflected to the ceiling from the walls, floor and furniture.

GLS-LCL Specifications

SPECIFICATION	DETAILS
Power Consumption	1W (42mA @ 24VDC)
Output	0 - 10VDC (0 - 70 footcandles)
Recommended Mounting Location	Directly above work space
Field of View Coverage	60° Cone

MOUNTING

NOTE: Care must be taken when choosing the mounting location.

It is recommended that the sensor be mounted directly above the work space, such as a desk, conference table or computer terminal.

Mounting location is important because the ambient light level will be different at different points in the room, depending on the location of the windows, lighting fixtures, wall colors, etc. The ambient light at the doorway can be much less than that at the windows, corners of the room, or especially on the ceiling. Therefore, it is important to measure the ambient light level over the workplace.

INSTALLATION

The GLS-LCL can either be fastened onto the ceiling surface, flush mounted into the ceiling, or installed in a 4 inch (10.2 cm) round or octagonal outlet box, depending on ceiling material and local codes.

1. To fasten the photocell to the ceiling surface, attach the outer shell provided to the ceiling at the desired location using two #4 screws and appropriate anchor hardware, where necessary. For concealed wiring, access to the space above the ceiling is required, as well as a hole in the ceiling above the photocell to connect the wires from the optional GLS-SIM or other Crestron interface device.

Make all connections as described in Steps 3 through 8. Carefully feed the wires into the hole and press the Photocell body into the outer shell until the rim is flush with the shell.

NOTE: If wiring is to be run exposed along the ceiling, carefully trim the plastic from the indentation in the side of the outer shell and lay the photocell wires through it before tightening the shell onto the ceiling.

2. To flush mount into the ceiling (only allows concealed wiring, the outer shell is not used), cut a 2 inch (5.1 cm) diameter hole through the ceiling. Make all connections as described in Steps 3 through 8. Carefully feed the wires back through the hole and press the GLS-LCL into the hole until the rim is flush with the ceiling.

INSTALLATION (Continued)

- Prepare the photocell lead wires by removing 3/4" (1.9 cm) of insulation from each lead to expose bare copper wire. Make sure the ends of wires are straight.
- Determine the length of low voltage wires needed to connect power to photocell. Use wires suitable for low-voltage wiring according to local electrical codes.
- Route low-voltage wires from GLS-LCL location(s) to interface device location(s). (Refer to the wiring diagrams in the next column.)
- Prepare low-voltage wires by removing 3/4 inch (1.9 cm) of insulation from each lead to expose bare copper wire. Make sure the ends of the wires are straight.
- Connect low voltage wires as shown in Figure 2 (black to ground, red to power, and orange to the interface device). Twist strands of each separate wire connection tightly, and push firmly into appropriate wire connector. Screw connector on clockwise ensuring no bare conductor shows below the wire connectors. Secure each connector with electrical tape.
- Mount GLS-LCL to the ceiling. **INSTALLATION IS COMPLETE.**

TROUBLESHOOTING

PROBLEM	POSSIBLE CAUSE	CORRECTIVE ACTION
Lights don't respond to change in ambient light level.	Incorrect wiring between sensor and GLS-SIM (or other compatible interface).	Refer to the wiring diagrams in the right column.
	Improper sensor location.	Verify that sensor is located such that it can detect the desired workspace light levels.
	Improper control system programming.	Check logic in control processor, or contact Crestron for assistance.

Field-of-View

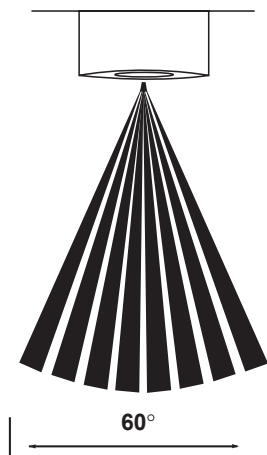

TYPICAL APPLICATION DIAGRAMS

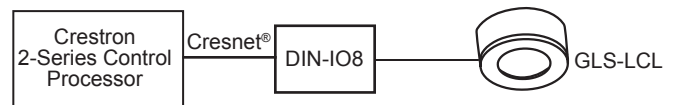

WIRING DIAGRAMS

Connecting Sensors to the GLS-SIM

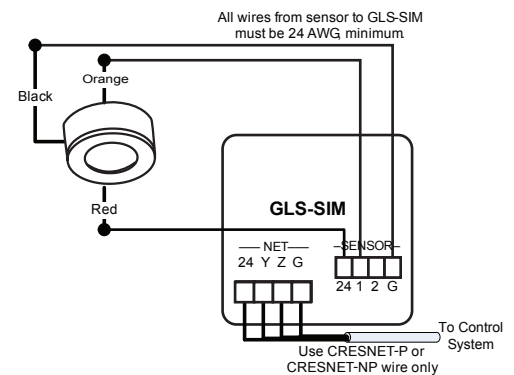

Connecting Sensors to the DIN-IO8 or Equivalent*

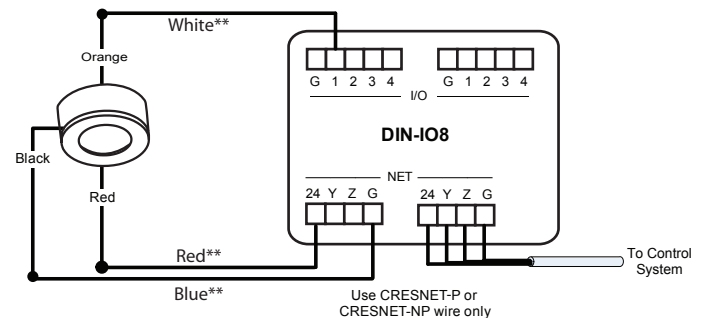

*The following Crestron devices may be used to integrate the sensors into a Cresnet system by following the schematic shown here:

DIN-IO8 DIN-AP2 PAC2 PRO2
 AV2 CP2E MP2E CNXIO16

** 250 feet max.

NOTE: The same Crestron power supply **MUST** be used to power both the sensors and the interface device (e.g., DIN-IO8). Otherwise, there is a risk of damage to the interface device.

Free Manuals Download Website

<http://myh66.com>

<http://usermanuals.us>

<http://www.somanuals.com>

<http://www.4manuals.cc>

<http://www.manual-lib.com>

<http://www.404manual.com>

<http://www.luxmanual.com>

<http://aubethermostatmanual.com>

Golf course search by state

<http://golfingnear.com>

Email search by domain

<http://emailbydomain.com>

Auto manuals search

<http://auto.somanuals.com>

TV manuals search

<http://tv.somanuals.com>