

Crestron Green Light™

DIN-1DIMU4

DIN Rail Universal Dimmer

Operations & Installation Guide



This document was prepared and written by the Technical Documentation department at:



Crestron Electronics, Inc.

15 Volvo Drive

Rockleigh, NJ 07647

1-888-CRESTRON

All brand names, product names and trademarks are the property of their respective owners.
©2008 Crestron Electronics, Inc.

Contents

Crestron Green Light™ DIN Rail Universal Dimmer: DIN-1DIMU4	1
Introduction	1
Features and Functions	1
Applications.....	4
Specifications	5
Physical Description.....	7
Industry Compliance	12
Setup.....	13
Network Wiring.....	13
Identity Code	13
Installation.....	14
Hardware Hookup	16
Programming Software.....	18
Earliest Version Software Requirements for the PC	18
Programming with Crestron SystemBuilder.....	18
Programming with D3 Pro.....	19
Programming with SIMPL Windows	19
Example Program	21
Uploading and Upgrading.....	22
Establishing Communication.....	22
Programs and Firmware	23
Program Checks	23
Operation	24
Problem Solving	26
Troubleshooting.....	26
Check Network Wiring.....	28
Reference Documents.....	29
Further Inquiries	29
Future Updates	30
Return and Warranty Policies.....	31
Merchandise Returns / Repair Service	31
CRESTRON Limited Warranty.....	31

Crestron Green Light™ DIN Rail Universal Dimmer: DIN-1DIMU4

Introduction

The DIN-1DIMU4 is a four channel universal lighting control module designed to support dimming of both forward and reverse phase type loads. A single model supports both 120 and 220-240 Volt electronic and magnetic low-voltage, incandescent, neon/cold cathode, two wire dimmable fluorescent and non-dimmable lighting loads up to 5 Amps per channel, 10 Amps total.

Features and Functions

- Four channels of forward or reverse phase dimming
- Auto load detection
- 120-240 Volt 50/60 Hz operation
- Selectable non-dim mode
- “Wilson” filter eliminates lamp flicker
- Short circuit and overload protection
- Master air gap relay
- Override input
- Cresnet® communications
- Setup via front panel or software
- Programmable functionality via DIN-AP2 or other 2-Series control system
- 12M wide DIN rail mounting

Auto Load Detection

Each channel of the DIN-1DIMU4 is capable of auto-detecting the dimmable load type connected to it and selecting the appropriate operating mode to control that load. Reverse phase (trailing edge) mode supports incandescent and electronic low-voltage load types, while forward phase (leading edge) mode handles magnetic low-voltage, neon and other inductive load types. A non-dim mode is also selectable for switching of non-dimmable lighting fixtures. Any channel may be set for any mode, allowing one dimmer module to handle any combination of lighting types on four separately controlled circuits.

Wilson Filter

A Crestron[®] proprietary zero cross filter technology, known as a Wilson filter, provides superior immunity to noise on the power line, eliminating lamp flicker and compensating for variations in the line voltage and frequency.

Short Circuit Protection

Built-in OCP (over current protection) prevents failure of the DIN-1DIMU4 caused by excessive loads or improper wiring of the outputs.

Master Air Gap Relay

When all four channels are turned fully off, the internal master relay automatically opens providing air gap isolation to allow safe servicing and changing of light bulbs on all four controlled circuits.

DIN Rail Installation

The DIN-1DIMU4 is designed to snap onto a standard DIN rail for installation in a wall mount enclosure. Wiring connections are made using detachable screw terminals and captive screws positioned along the bottom, clearly accessible from the front for easy installation and servicing. All setup controls and indicators are positioned on the center front panel. When installed in an enclosure utilizing 45 mm cutouts, the DIN-1DIMU4's front panel stays accessible while the connections are concealed.

Cresnet[®]

The DIN-1DIMU4 communicates with a DIN-AP2 2-Series Automation Processor or other Crestron 2-Series control system via the Cresnet control network. A pair of Cresnet ports is provided on the DIN-1DIMU4 allowing for easy daisy chaining of several DIN Rail Series automation control modules.

Override Input

An override input is provided to allow an external contact closure to momentarily override the control system program and set each channel output to its override preset level. Levels can be adjusted and saved locally from the front panel or remotely via software.

Applications

The following diagram shows a DIN-1DIMU4 in a typical application.

DIN-1DIMU4 in a Typical Application

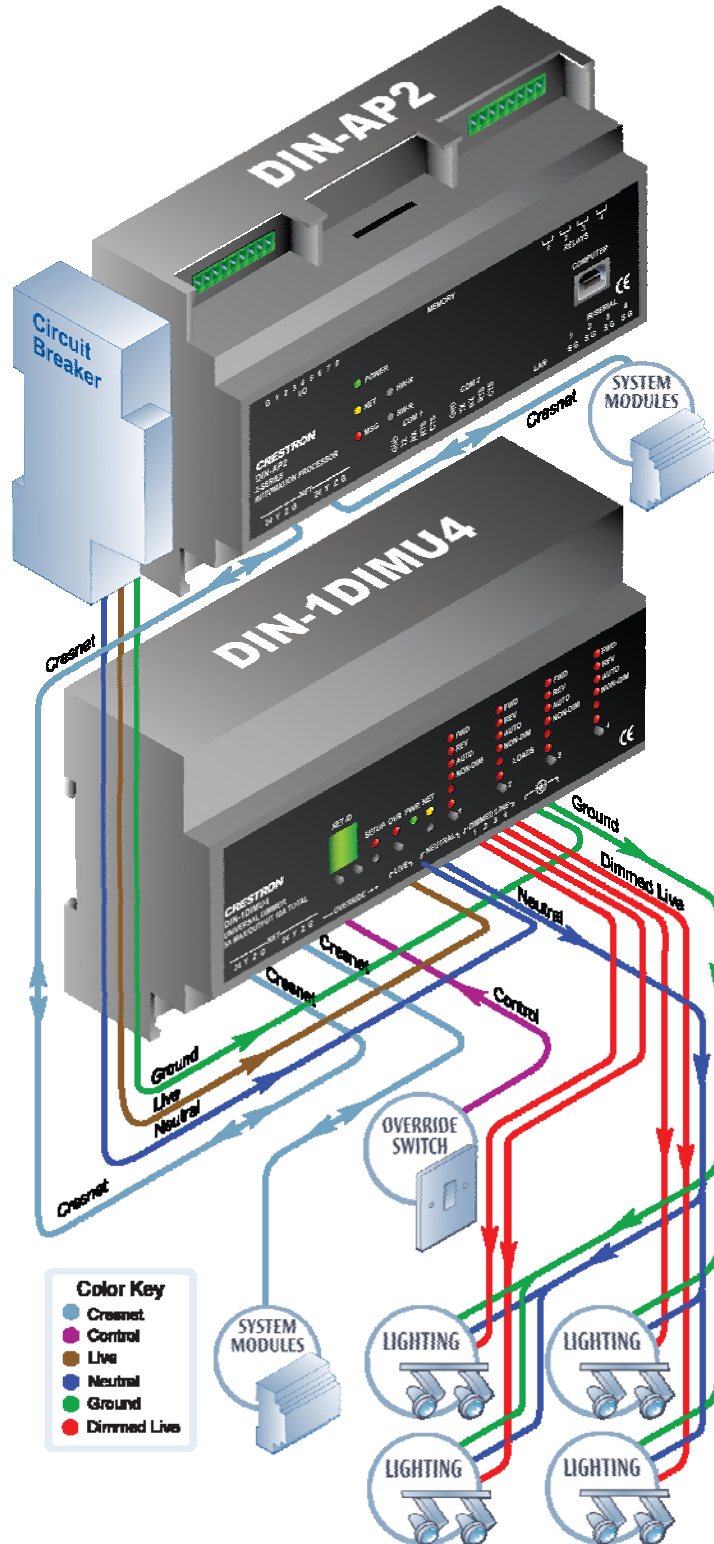

Specifications

Specifications for the DIN-1DIMU4 are listed in the following table.

DIN-1DIMU4 Specifications

SPECIFICATION	DETAILS
Load Ratings	
Dimmer Channels	4
Maximum Per Channel	5 Amps @ 120-240 Volts AC, 50/60 Hz; 600 Watts @ 120 Volts AC, 1150 Watts @ 230 Volts AC, 1200 Watts @ 240 Volts AC
Module Total	10 Amps @ 120-240 Volts AC, 50/60 Hz; 1200 Watts @ 120 Volts AC, 2300 Watts @ 230 Volts AC, 2400 Watts @ 240 Volts AC
Load Types	Forward phase (leading edge) or reverse phase (trailing edge) electronic low-voltage, incandescent, neon/cold cathode, magnetic low-voltage, dimmable two wire fluorescent and non-dim lighting
Input Voltages	
Line Power	120-240 Volts AC, 50/60 Hz
Power Requirements	
Cresnet Power Usage	0.6 Watts (25 mA @ 24 Volts DC)
Default Net ID	86
Minimum 2-Series Control System Update File ^{1,2}	Version 4.000.0226 or later

(Continued on following page)

DIN-1DIMU4 Specifications (Continued)

SPECIFICATION	DETAILS
Environmental Temperature Humidity Heat Dissipation	0° to 40° C (32° to 104° F) 10% to 90% RH (non-condensing) 60 BTU/Hr @ 240 Volts with two channels @ 5A 50 BTU/Hr @ 120 Volts with two channels @ 5A
Enclosure	Aluminum with polycarbonate label overlay, 35 mm DIN EN 60715 rail mount, DIN 43880 form factor for enclosures with 45 mm front panel cutout, occupies 12 DIN module spaces (216 mm) ³
Dimensions Height Width Depth	94.2 mm (3.71 in) 215.5 mm (8.49 in) 59.5 mm (2.35 in)
Weight	912 g (32 oz)
Available Accessories DIN-BLOCK DIN-HUB DIN-PWS50	DIN Rail Cresnet Distribution Block DIN Rail Cresnet Distribution Hub DIN Rail 50 Watt Cresnet Power Supply

1. The latest software versions can be obtained from the Crestron website. Refer to the NOTE following these footnotes.
2. Crestron 2-Series control systems include the AV2 and PRO2. Consult the latest Crestron Product Catalog for a complete list of 2-Series control systems.
3. The DIN-1DIMU4 dissipates significant heat when fully loaded and should be mounted in a suitably ventilated enclosure. Maintain 10 cm (4 in) minimum spacing above and below for proper ventilation and heat dissipation, 15 cm (6 in) spacing recommended. When mounting multiple DIN1DIMU4 modules, the ambient temperature within the enclosure must not exceed 40° C (104° F).

Operating the module above its maximum operating temperature may result in the unit overheating and shutting down.

NOTE: Crestron software and any files on the website are for authorized Crestron dealers and Crestron Authorized Independent Programmers (CAIP) only. New users may be required to register to obtain access to certain areas of the site (including the FTP site).

Physical Description

This section provides information on the connections, controls and indicators available on your DIN-1DIMU4.

DIN-1DIMU4 Physical View



DIN-1DIMU4 Overall Dimensions

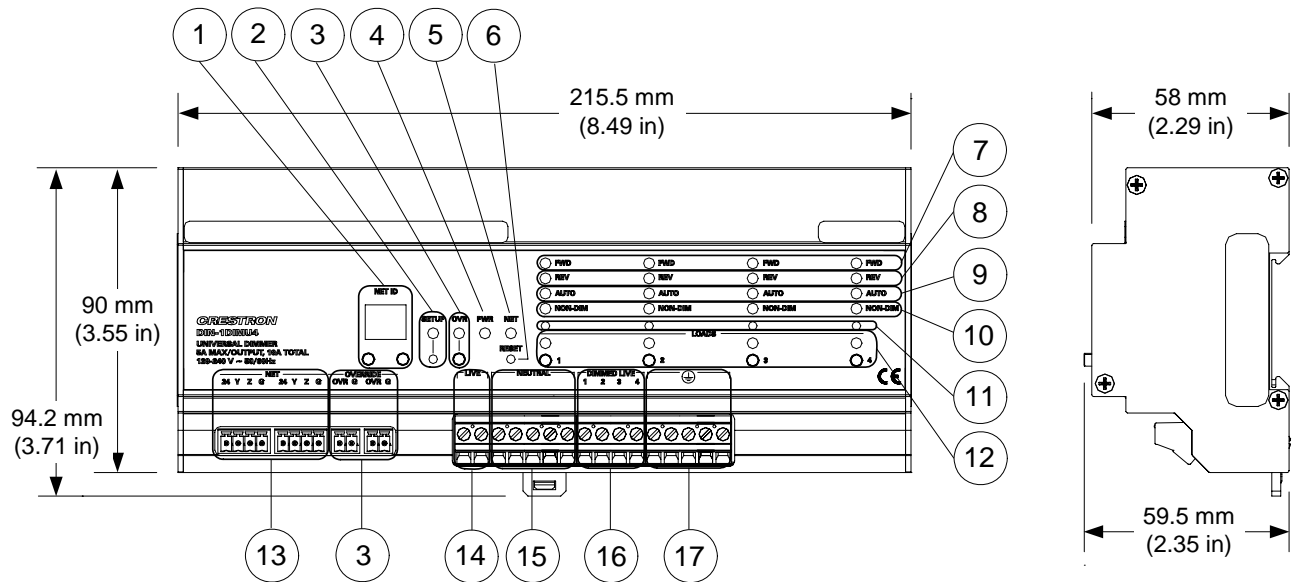

Connectors, Controls & Indicators

#	CONNECTORS ¹ , CONTROLS & INDICATORS	DESCRIPTION
1	<p>NET ID DISPLAY and CONTROL</p> <p>NET ID</p>	(2) 7-Segment green LED digits and (2) miniature pushbuttons for setting Cresnet ID, display output levels and indicating errors
2	<p>SETUP (LED and BUTTON)</p>	(1) Red LED and (1) recessed miniature pushbutton for enabling setup mode and touch-settable ID

(Continued on following page)

Connectors, Controls & Indicators (Continued)

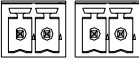
#	CONNECTORS ¹ , CONTROLS & INDICATORS	DESCRIPTION
3	<p style="text-align: center;">OVERRIDE with LEDs and BUTTON</p> <p style="text-align: center;">—OVERRIDE— OVR G OVR G</p> 	<p>(2) 2-pin 3.5 mm detachable terminal blocks, paralleled; Maximum wire size: 1.5 mm² (16 AWG) Sensing input for external low-voltage contact closure; Activates <i>Override</i> mode when a closure is present; Minimum closure rating: 10 mA (per module) at 24 Volts (1) Red LED and (1) miniature pushbutton for enabling <i>Override</i> mode and saving override presets. For more information, refer to “Operation” which starts on page 24.</p>
4	PWR	(1) Green LED, solid on indicates AC line power is connected to either LIVE terminal, blinking indicates power from Cresnet but no AC power
5	NET	(1) Yellow LED, indicates communication with the control processor
6	RESET	(1) Recessed miniature pushbutton, resets internal processor
7	FWD (1 – 4)	(4) Red LEDs, illuminate when a corresponding channel is operating in a forward phase mode

(Continued on following page)

Connectors, Controls & Indicators (Continued)

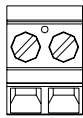
#	CONNECTORS ¹ , CONTROLS & INDICATORS	DESCRIPTION
8	REV (1 – 4)	(4) Red LEDs, illuminate when a corresponding channel is operating in a reverse phase mode
9	AUTO (1 – 4)	(4) Red LEDs, illuminate when a corresponding channel is set to auto-detect the load type
10	NON-DIM (1 – 4)	(4) Red LEDs, illuminate when a corresponding channel is operating in non-dim mode
11	CHANNEL MODE SELECT (1 – 4)	(4) Recessed miniature pushbuttons, used to select each channel's operating mode
12	LOADS (1 – 4)	(4) Red LEDs and (4) miniature pushbuttons for status indication and local control of each channel
13	<p>NET</p> <p>NET</p> <p>24 Y Z G 24 Y Z G</p> 	<p>(2) 4-pin 3.5 mm detachable terminal blocks, paralleled Cresnet slave port</p> <p>Connects to Cresnet control network.</p> <p>Maximum wire size: 1.5 mm² (16 AWG)</p> <p>24: Power (24 Volts DC)</p> <p>Y: Data</p> <p>Z: Data</p> <p>G: Ground</p>
14	<p>LIVE</p> <p>LIVE</p> 	<p>(2) Captive screw terminals², brown;</p> <p>Line power input</p>

(Continued on following page)

Connectors, Controls & Indicators (Continued)

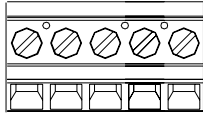
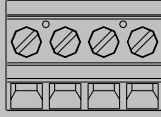
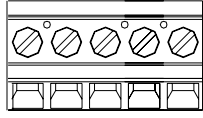
#	CONNECTORS ¹ , CONTROLS & INDICATORS	DESCRIPTION
15	<p style="text-align: center;">NEUTRAL</p> <p style="text-align: center;">┌── NEUTRAL ──┐</p> 	(5) Captive screw terminals ² , blue
16	<p style="text-align: center;">DIMMED LIVE (1 – 4)</p> <p style="text-align: center;">┌── DIMMED LIVE ──┐</p> <p style="text-align: center;">1 2 3 4</p> 	(4) Captive screw terminals ² , red; Dimmer channel outputs 1 - 4
17	<p style="text-align: center;">GROUND</p> <p style="text-align: center;">┌── ⊕ ──┐</p> 	(5) Captive screw terminals ² , green

1. Interface connectors for **NET** and **OVERRIDE** ports are provided with the unit.
2. Captive screw terminals accept up to 2.5 mm² (12 AWG) wires per terminal.

Industry Compliance

This unit has been manufactured to comply with UL's Standards for Safety in Canada and the United States. Formal approval is pending.

As of the date of manufacture, the DIN-1DIMU4 has been tested and found to comply with specifications for CE marking and standards per EMC and Radiocommunications Compliance Labelling.



NOTE: This device complies with part 15 of the FCC rules. Operation is subject to the following two conditions: (1) this device may not cause harmful interference and (2) this device must accept any interference received, including interference that may cause undesired operation.

This equipment has been tested and found to comply with the limits for a Class B digital device, pursuant to part 15 of the FCC Rules. These limits are designed to provide reasonable protection against harmful interference in a residential installation. This equipment generates, uses and can radiate radio frequency energy and if not installed and used in accordance with the instructions, may cause harmful interference to radio communications. However, there is no guarantee that interference will not occur in a particular installation. If this equipment does cause harmful interference to radio or television reception, which can be determined by turning the equipment off and on, the user is encouraged to try to correct the interference by one or more of the following measures:

- Reorient or relocate the receiving antenna.
 - Increase the separation between the equipment and receiver.
 - Connect the equipment into an outlet on a circuit different from that to which the receiver is connected.
 - Consult the dealer or an experienced radio/TV technician for help.
-

Setup

Network Wiring

When wiring the Cresnet network, consider the following:

- Use Crestron Certified Wire.

NOTE: Cresnet HP cannot be used.

- Use Crestron power supplies for Crestron equipment.
- Provide sufficient power to the system.

CAUTION: Insufficient power can lead to unpredictable results or damage to the equipment. Please use the Crestron Power Calculator to help calculate how much power is needed for the system (www.crestron.com/calculators).

- Use of a Cresnet hub/repeater (DIN-HUB) is advised whenever the number of Cresnet devices on a network exceeds 20 or when the combined total length of Cresnet cable exceeds 914 meters (3000 feet).

For more details, refer to “Check Network Wiring” which starts on page 28.

Identity Code

The Net ID of the DIN-1DIMU4 has been factory set to **86**. The Net IDs of multiple DIN-1DIMU4 devices in the same system must be unique. Net IDs are changed on the front panel of the DIN-1DIMU4 or from a personal computer (PC) via Crestron Toolbox™ (refer to “Establishing Communication” on page 22).

To set the Net ID using the front panel:

- Press the **SETUP** button to enter the *Setup* mode. The **SETUP** LED illuminates.
- Press the left button under the **NET ID** display to change the most significant digit of the Net ID or press the right button under the

NET ID display to change the least significant digit of the Net ID number.

- When the desired Net ID is displayed, press the **SETUP** button to exit the *Setup* mode. The **SETUP** LED extinguishes.

NOTE: If an invalid Net ID is set (00, 02, FF), “Er” will be displayed on the **NET ID** display. The DIN-1DIMU4 will revert to the previously set Net ID.

NOTE: The DIN-1DIMU4 will leave the *Setup* mode after 10 seconds of inactivity. The DIN-1DIMU4 will revert to the previously set Net ID.

NOTE: A small label (with numbers and letters) is provided on the front panel of the DIN-1DIMU4 to document the unit’s Net ID in the case where power is not available. Apply a mark over the digits that correspond to the assigned Net ID.

NET ID Label (“3C” Shown)



When setting the Net ID, consider the following:

- The Net ID of each unit must match an ID code specified in the SIMPL™ Windows® program.
- Each network device must have a unique Net ID.

For more details, refer to the Crestron Toolbox help file.

Installation

The DIN-1DIMU4 must be installed by a licensed electrician, in accordance with all national and local codes.

CAUTION: This equipment is for indoor use only. Mount in a well ventilated area. The ambient temperature must be 0° to 40° C (32° to 104° F). The relative humidity must be 10% – 90% (non-condensing).

NOTE: When installing in an enclosure, high-voltage devices should be grouped separately from low-voltage devices.

The DIN-1DIMU4 is designed for installation on a DIN rail. Refer to the following diagram when installing.

Installing the DIN-1DIMU4

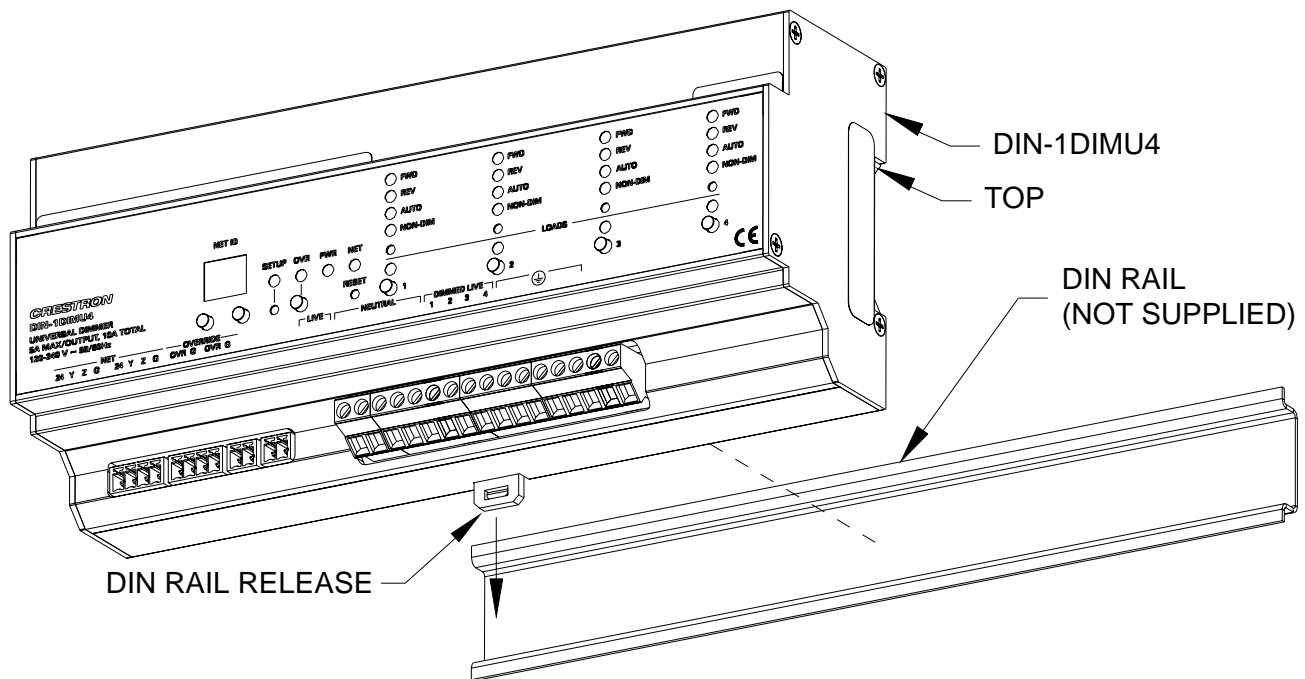

1. Use a flat object (i.e. a flat-head screwdriver) to pull the DIN rail release downward.
2. With the top of the unit tilted toward you, place the DIN-1DIMU4 against the bottom of the DIN rail.

NOTE: When mounting DIN rail products, it may be necessary to use a flat-head screwdriver to pull the DIN rail release tab while snapping the device onto the DIN rail.

3. Tilt the top of the DIN-1DIMU4 toward the DIN rail until it is secure on the top edge of the rail. Push the DIN rail release upward to lock the DIN-1DIMU4 into place.

To remove the DIN-1DIMU4 from the DIN rail, use a small, flat object (i.e. a flat-head screwdriver) to pull the DIN rail release downward to unlock it and tilt the top of the DIN-1DIMU4 away from the DIN rail.

NOTE: Certain third party DIN cabinets provide space for an informational label between each DIN rail row. Crestron's Engraver software (version 4.0 or later) can generate appropriate labels for all Crestron DIN rail products.

Hardware Hookup

Make the necessary connections as called out in the illustration that follows this paragraph. Refer to "Network Wiring" on page 13 before attaching the 4-position terminal block connector. Apply power after all connections have been made.

WARNING: Prior to connecting the device, turn off power at the circuit breaker. Failure to do so may result in serious personal injury or damage to the device. Restore power after all connections have been made.

CAUTION: Connecting this device to the wrong type of load or short-circuiting the load can cause severe product damage. Each load should be tested to identify a short circuit condition prior to wiring the load to the module.

NOTE: Install in accordance with all local and national electric codes.

NOTE: High-voltage connections accept 2.5 mm² (12 AWG) wire. Wire should be stripped to 8 mm (1/3 inch). Tighten terminal blocks to 0.5 Nm (5 in-lbs).

NOTE: Use copper wire only. For high-voltage connections, use wire rated for at least 75° C (167° F).

NOTE: The DIN-1DIMU4 power feed must be protected by a 10 A (trip curve C) breaker or equivalent.

NOTE: The DIN-1DIMU4 outputs must be used for control of permanently installed lighting loads only.

NOTE: Do not mix magnetic and electronic transformers on the same dimmer output.

NOTE: Ensure the unit is properly grounded.

When making network connections to the DIN-1DIMU4, use a Crestron power supply.

Hardware Connections for the DIN-1DIMU4

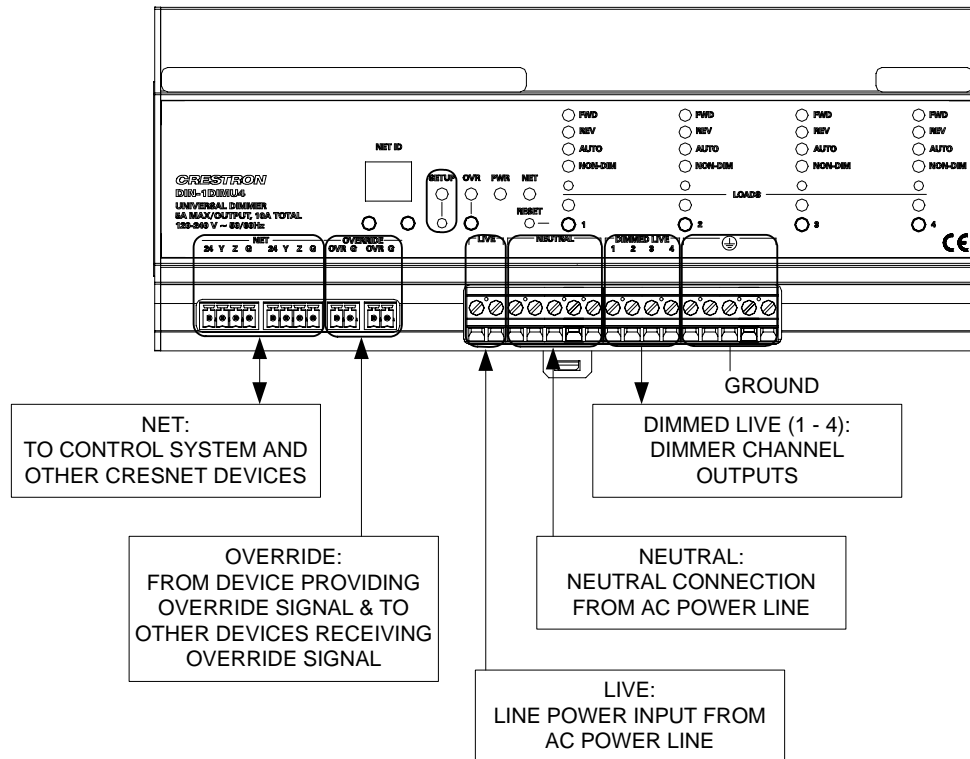

With the circuit breaker turned off, connect the wires to the terminal blocks per the markings provided on the DIN-1DIMU4.

Load Connection Example for the DIN-1DIMU4

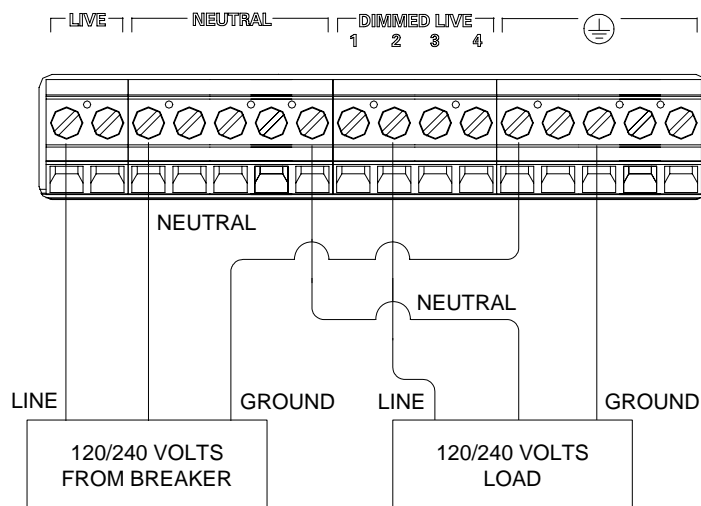

Programming Software

Have a question or comment about Crestron software?

Answers to frequently asked questions (FAQs) can be viewed in the Online Help section of the Crestron website. To post a question or view questions you have submitted to Crestron's True Blue Support, log in at <http://support.crestron.com>. First-time users will need to establish a user account.

Earliest Version Software Requirements for the PC

NOTE: Crestron recommends that you use the latest software to take advantage of the most recently released features. The latest software is available from the Crestron website.

Crestron has developed an assortment of Windows[®]-based software tools to develop a Cresnet system. You can create a program to control the DIN-1DIMU4 using the Crestron programming tools Crestron SystemBuilder, D3 Pro™ or SIMPL Windows. Customers whose focus is on lighting systems may prefer to use the D3 Pro software since it is designed especially for creating lighting and environmental system control applications. Customers already familiar with SIMPL Windows who are including a lighting system as part of an overall control system project may prefer to continue using SIMPL Windows. For the minimum recommended software versions, visit the Version Tracker page of the Crestron website (www.crestron.com/versiontracker).

Programming with Crestron SystemBuilder

Crestron SystemBuilder is the easiest method of programming but does not offer as much flexibility as SIMPL Windows. For additional details, download SystemBuilder from the Crestron website and examine the extensive help file.

Programming with D3 Pro

Crestron's D3 Pro lighting software provides all the tools necessary to create a complete Crestron lighting system for residential applications. The lighting system includes the control system logic program, touchpanel projects and keypad programming, documentation and real-time lighting adjustment capabilities.

As with all Crestron software, D3 Pro provides extensive right-click and drag-and-drop functionality in addition to convenient keyboard shortcuts for frequently used functions and commands.

Programming is organized into six system **Views** of the lighting system, each providing a moveable toolbox of devices such as interfaces, fixtures and control modules. You can add a device to your system simply by selecting it from one of the toolboxes and dragging it to a room. The available toolboxes differ depending on the View but all Views include a "General" toolbox that allows you to add areas and rooms at any time.

Programming with SIMPL Windows

NOTE: While SIMPL Windows can be used to program the DIN-1DIMU4, it is recommended to use SystemBuilder for configuring a system.

SIMPL Windows is Crestron's premier software for programming Crestron control systems. It is organized into two separate but equally important "Managers".

Configuration
Manager

Configuration Manager is the view where programmers "build" a Crestron control system by selecting hardware from the *Device Library*.

- To incorporate the DIM-1DIMU4 into the system, drag the DIN-1DIMU4 from the Lighting | Lighting (Din-Rail Series) folder of the *Device Library* and drop it in the *System Views*.

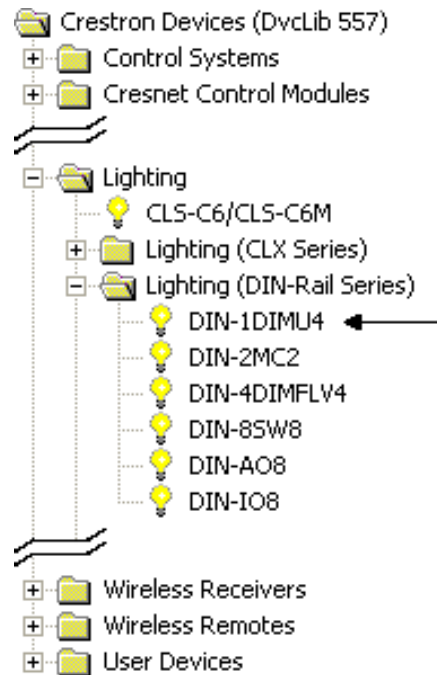
Locating the DIN-1DIMU4 in the Device Library

- The system tree of the control system displays the device in the appropriate slot with a default Net ID as shown in the following illustration.

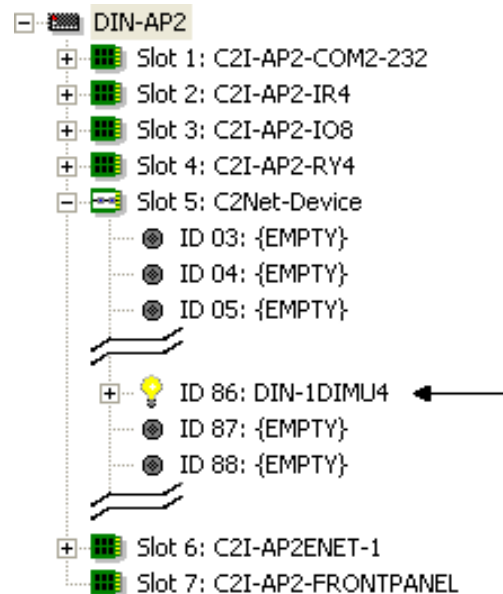
C2Net Device, Slot 5

- Additional DIN-1DIMU4 devices are assigned different Net ID numbers as they are added.

- If necessary, double click a device to open the “Device Settings” window and change the Net ID, as shown in the following figure.

“DIN-1DIMU4 Device Settings” Window

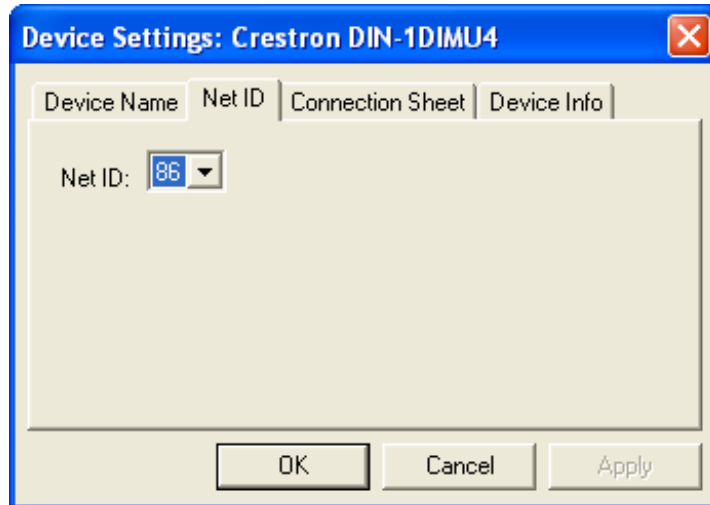

- The ID code specified in the SIMPL Windows program must match the Net ID of each unit. Refer to “Identity Code” which starts on page 13.

Program Manager

Program Manager is the view where programmers “program” a Crestron control system by assigning signals to symbols.

The symbol can be viewed by double clicking on the icon or dragging it into *Detail View*. Each signal in the symbol is described in the SIMPL Windows help file (**F1**).

Example Program

An example program for the DIN-1DIMU4 is available from the Crestron website (www.crestron.com/exampleprograms).

Uploading and Upgrading

Crestron recommends using the latest programming software and that each device contains the latest firmware to take advantage of the most recently released features. However, before attempting to upload or upgrade it is necessary to establish communication. Once communication has been established, files (for example, programs or firmware) can be transferred to the control system (and/or device). Finally, program checks can be performed (such as changing the device ID or creating an IP table) to ensure proper functioning.

Establishing Communication

Use Crestron Toolbox for communicating with the DIN-1DIMU4; refer to the Crestron Toolbox help file for details. There is a single method of communication: indirect communication.

Indirect Communication

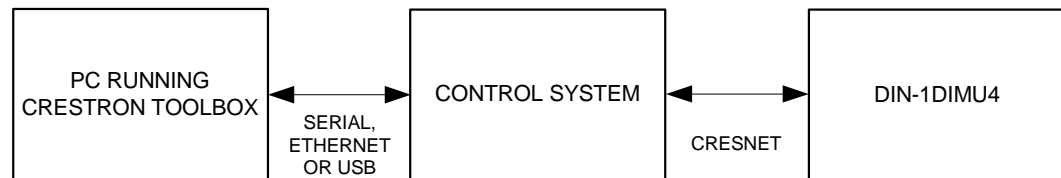

- DIN-1DIMU4 connects to control system via Cresnet.
- Establish communication between the PC and the control system as described in the latest version of the 2-Series Control Systems Reference Guide (Doc. 6256), which is available from the Crestron website (www.crestron.com/manuals).
- Use the Address Book in Crestron Toolbox to create an entry for the DIN-1DIMU4 using the expected communication protocol (Indirect). Select the Cresnet ID of the DIN-1DIMU4 and the address book entry of the control system that is connected to the DIN-1DIMU4.
- Display the DIN-1DIMU4's "System Info" window (click the  icon); communications are confirmed when the device information is displayed.

Programs and Firmware

Program or firmware files may be distributed from programmers to installers or from Crestron to dealers. Firmware upgrades are available from the Crestron website as new features are developed after product releases. One has the option to upload programs via the programming software or to upload and upgrade via the Crestron Toolbox. For details on uploading and upgrading, refer to the SIMPL Windows help file or the Crestron Toolbox help file.

SIMPL Windows

If a SIMPL Windows program is provided, it can be uploaded to the control system using SIMPL Windows or Crestron Toolbox.

Firmware

Check the Crestron website to find the latest firmware. (New users may be required to register to obtain access to certain areas of the site, including the FTP site.)

Upgrade DIN-1DIMU4 firmware via Crestron Toolbox.

- Establish communication with the DIN-1DIMU4 and display the “System Info” window.
- Select **Functions | Firmware...** to upgrade the DIN-1DIMU4 firmware.

Program Checks

Using Crestron Toolbox, display the network device tree (**Tools | Network Device Tree**) to show all network devices connected to the control system. Right-click on the DIN-1DIMU4 to display actions that can be performed on the DIN-1DIMU4.

Operation

NET ID

Use the **NET ID** buttons to change the Net ID of the DIN-1DIMU4. For information on Net ID, refer to “Identity Code” which starts on page 13.

Manual Control

The lighting level of each output can be manually controlled from the front panel.

To toggle the light between off and 100% (on), tap the appropriate **LOAD** button. The corresponding LED illuminates and the output level is shown on the **NET ID** display (“oF” for off, “On” for on) for two seconds after the button is released.

To ramp the lighting level up or down (until it reaches a limit), press and hold the appropriate **LOAD** button. To change the ramp direction, release **LOAD** button, then press and hold it again. The corresponding LED illuminates and the output level is shown on the **NET ID** display as a percentage (01-99) for two seconds after the button is released.

NOTE: The control system program may change the settings if the *Override* mode is not enabled.

Override Mode

The *Override* mode overrides the control system program and sets all of the lighting levels to the stored override values. For instructions on saving override settings, refer to “Save Override Settings” on page 25.

To enable *Override* mode, press and release the **OVR** button. The **OVR** LED flashes slowly.

NOTE: If the *Override* mode was enabled from an external device (i.e. a contact closure is present on the **OVERRIDE** terminals), the **OVR** LED will flash quickly. Pressing the **OVR** button has no effect.

To disable *Override* mode, press the **OVR** button again. The **OVR** LED extinguishes and the lights return to the levels set by the control system program.

NOTE: If override levels have not been saved, the factory default override level is 100%.

**Save
Override
Settings**

The lighting level of each output can be saved as an override setting, which can be automatically recalled when the *Override* mode is enabled.

NOTE: The control system program has a setting that can prevent locally saving the override level settings. If this setting is enabled, the display shows “Er” when trying to save override level settings. For more information, refer to the SIMPL Windows help file.

To save the current lighting level values as override settings, press and hold the **OVR** button for three seconds. The **OVR** LED blinks to indicate the new override setting has been stored.

Reset

To reboot the DIN-1DIMU4, press the **RESET** button. The lighting levels will be set to the levels currently specified by the control system program. If the control system does not provide any values, the lighting levels will be set to the previously set values.

Problem Solving

Troubleshooting

The following table provides corrective action for possible trouble situations. If further assistance is required, please contact a Crestron customer service representative.

DIN-1DIMU4 Troubleshooting

TROUBLE	POSSIBLE CAUSE(S)	CORRECTIVE ACTION
Device does not function.	DIN-1DIMU4 is not receiving power from the AC line or the Crestron power supply.	Ensure circuit breaker is not tripped.
	Device is not receiving power from a Crestron power source.	Use a Crestron power source. Verify connections.
	Device is not receiving sufficient power.	Use the Crestron Power Calculator to help calculate how much power is needed for the system.
	Electrostatic discharge due to improper grounding.	Check that all ground connections have been made properly.
PWR LED blinks.	DIN-1DIMU4 is not receiving power from the AC line.	Ensure circuit breaker is not tripped.

(Continued on following page)

DIN-1DIMU4 Troubleshooting (Continued)

TROUBLE	POSSIBLE CAUSE(S)	CORRECTIVE ACTION
LOADS (status) LED on a channel is blinking once per second.	Over current protection has tripped.	Check wiring on corresponding output for a short circuit. Check total load on corresponding output for an overload.
LOADS (status) LED on a channel is blinking twice per second.	Channel has been programmed to use reverse phase control (REV) but has detected a magnetic load connected.	Change programming to use AUTO or FWD .
LOADS (status) LED on a channel is blinking three times per second.	The channel has overheated and shut down to protect itself.	Reduce loading on the channel. Reduce loading on the module. Improve enclosure ventilation to reduce ambient temperature.
Unit ignores Cresnet commands.	Unit is in <i>Override</i> mode.	Take out of <i>Override</i> mode by pressing OVR button or releasing override contact closure.

Check Network Wiring

Use the Right Wire

In order to ensure optimum performance over the full range of your installation topology, Crestron Certified Wire and only Crestron Certified Wire may be used. Failure to do so may incur additional charges if support is required to identify performance deficiencies because of using improper wire.

Calculate Power

CAUTION: Use only Crestron power supplies for Crestron equipment. Failure to do so could cause equipment damage or void the Crestron warranty.

CAUTION: Provide sufficient power to the system. Insufficient power can lead to unpredictable results or damage to the equipment. Please use the Crestron Power Calculator to help calculate how much power is needed for the system (www.crestron.com/calculators).

When calculating the length of wire for a particular Cresnet run, the wire gauge and the Cresnet power usage of each network unit to be connected must be taken into consideration. Use Crestron Certified Wire only. If Cresnet units are to be daisy-chained on the run, the Cresnet power usage of each network unit to be daisy-chained must be added together to determine the Cresnet power usage of the entire chain. If the unit is home-run from a Crestron system power supply network port, the Cresnet power usage of that unit is the Cresnet power usage of the entire run. The wire gauge and the Cresnet power usage of the run should be used in the following equation to calculate the cable length value on the equation's left side.

Cable Length Equation

$$L < \frac{40,000}{R \times P}$$

Where:
 L = Length of run (or chain) in feet
 R = 6 Ohms (Crestron Certified Wire: 0.75 MM²(18 AWG))
 P = Cresnet power usage of entire run (or chain)

Make sure the cable length value is less than the value calculated on the right side of the equation. For example, a Cresnet run using 0.75 mm² (18 AWG) Crestron Certified Wire and drawing 20 watts should not have a length of run more than 101 meters (333 feet). Cresnet HP cannot be used.

NOTE: All Crestron certified Cresnet wiring must consist of two twisted pairs. One twisted pair is the +24V conductor and the GND conductor and the other twisted pair is the Y conductor and the Z conductor.

Strip and Tin Wire

When daisy-chaining Cresnet units, strip the ends of the wires carefully to avoid nicking the conductors. Twist together the ends of the wires that share a pin on the network connector and tin the twisted connection. Apply solder only to the ends of the twisted wires. Avoid tinning too far up the wires or the end becomes brittle. Insert the tinned connection into the Cresnet connector and tighten the retaining screw. Repeat the procedure for the other three conductors.

Add Hubs

Use of a Cresnet hub/repeater (DIN-HUB) is advised whenever the number of Cresnet devices on a network exceeds 20 or when the combined total length of Cresnet cable exceeds 914 meters (3000 feet).

Reference Documents

The latest version of all documents mentioned within the guide can be obtained from the Crestron website (www.crestron.com/manuals). This link will provide a list of product manuals arranged in alphabetical order by model number.

List of Related Reference Documents

DOCUMENT TITLE
2-Series Control Systems Reference Guide

Further Inquiries

If you cannot locate specific information or have questions after reviewing this guide, please take advantage of Crestron's award winning customer service team by calling Crestron at 1-888-CRESTRON [1-888-273-7876].

You can also log onto the online help section of the Crestron website (www.crestron.com/onlinehelp) to ask questions about Crestron products. First-time users will need to establish a user account to fully benefit from all available features.

Future Updates

As Crestron improves functions, adds new features and extends the capabilities of the DIN-1DIMU4, additional information may be made available as manual updates. These updates are solely electronic and serve as intermediary supplements prior to the release of a complete technical documentation revision.

Check the Crestron website periodically for manual update availability and its relevance. Updates are identified as an “Addendum” in the Download column.

Return and Warranty Policies

Merchandise Returns / Repair Service

1. No merchandise may be returned for credit, exchange or service without prior authorization from CRESTRON. To obtain warranty service for CRESTRON products, contact an authorized CRESTRON dealer. Only authorized CRESTRON dealers may contact the factory and request an RMA (Return Merchandise Authorization) number. Enclose a note specifying the nature of the problem, name and phone number of contact person, RMA number and return address.
2. Products may be returned for credit, exchange or service with a CRESTRON Return Merchandise Authorization (RMA) number. Authorized returns must be shipped freight prepaid to CRESTRON, 6 Volvo Drive, Rockleigh, N.J. or its authorized subsidiaries, with RMA number clearly marked on the outside of all cartons. Shipments arriving freight collect or without an RMA number shall be subject to refusal. CRESTRON reserves the right in its sole and absolute discretion to charge a 15% restocking fee plus shipping costs on any products returned with an RMA.
3. Return freight charges following repair of items under warranty shall be paid by CRESTRON, shipping by standard ground carrier. In the event repairs are found to be non-warranty, return freight costs shall be paid by the purchaser.

CRESTRON Limited Warranty

CRESTRON ELECTRONICS, Inc. warrants its products to be free from manufacturing defects in materials and workmanship under normal use for a period of three (3) years from the date of purchase from CRESTRON, with the following exceptions: disk drives and any other moving or rotating mechanical parts, pan/tilt heads and power supplies are covered for a period of one (1) year; touchscreen display and overlay components are covered for 90 days; batteries and incandescent lamps are not covered.

This warranty extends to products purchased directly from CRESTRON or an authorized CRESTRON dealer. Purchasers should inquire of the dealer regarding the nature and extent of the dealer's warranty, if any.

CRESTRON shall not be liable to honor the terms of this warranty if the product has been used in any application other than that for which it was intended or if it has been subjected to misuse, accidental damage, modification or improper installation procedures. Furthermore, this warranty does not cover any product that has had the serial number altered, defaced or removed.

This warranty shall be the sole and exclusive remedy to the original purchaser. In no event shall CRESTRON be liable for incidental or consequential damages of any kind (property or economic damages inclusive) arising from the sale or use of this equipment. CRESTRON is not liable for any claim made by a third party or made by the purchaser for a third party.

CRESTRON shall, at its option, repair or replace any product found defective, without charge for parts or labor. Repaired or replaced equipment and parts supplied under this warranty shall be covered only by the unexpired portion of the warranty.

Except as expressly set forth in this warranty, CRESTRON makes no other warranties, expressed or implied, nor authorizes any other party to offer any warranty, including any implied warranties of merchantability or fitness for a particular purpose. Any implied warranties that may be imposed by law are limited to the terms of this limited warranty. This warranty statement supersedes all previous warranties.

Trademark Information

All brand names, product names and trademarks are the sole property of their respective owners. Windows is a registered trademark of Microsoft Corporation. Windows95/98/Me/XP/Vista and WindowsNT/2000 are trademarks of Microsoft Corporation.



Crestron Electronics, Inc.
15 Volvo Drive Rockleigh, NJ 07647
Tel: 888.CRESTRON
Fax: 201.767.7576
www.crestron.com

**Operations & Installation Guide – DOC. 6668A
(2020750)
06.08**

Specifications subject to
change without notice.

Free Manuals Download Website

<http://myh66.com>

<http://usermanuals.us>

<http://www.somanuals.com>

<http://www.4manuals.cc>

<http://www.manual-lib.com>

<http://www.404manual.com>

<http://www.luxmanual.com>

<http://aubethermostatmanual.com>

Golf course search by state

<http://golfingnear.com>

Email search by domain

<http://emailbydomain.com>

Auto manuals search

<http://auto.somanuals.com>

TV manuals search

<http://tv.somanuals.com>