

**EARLEX<sup>®</sup>**  
**Super Sprayer 85**  
**SG85**

**OPERATING INSTRUCTIONS**

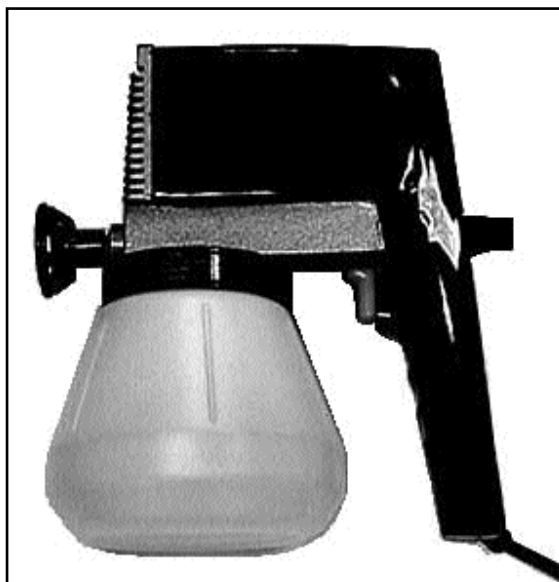

Thank you for purchasing the Earlex SG85 Electric Airless Spray Gun, this is a highly versatile spray gun and can be used for a variety of applications.

**BEFORE USE - PLEASE READ THE SAFETY  
& OPERATING INSTRUCTIONS**

**Please retain for future reference**

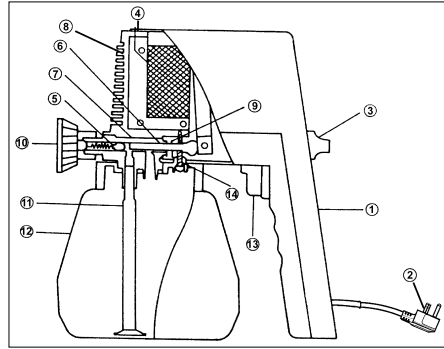

- 1) Handle
- 2) Mains Lead and Plug
- 3) Output Control Knob
- 4) Electromagnetic Motor
- 5) Atomiser valve
- 6) Piston
- 7) Cylinder Housing
- 8) Drive Housing with Stator
- 9) Piston Spring
- 10) Spray Nozzle
- 11) Suction Tube
- 12) Paint Container
- 13) Switch
- 14) Screw

### OUTFIT COMPONENTS AND USES

Your complete Earlex SG85 Electric Airless Spray Gun outfit includes:

▪ Professional sprayer with 0.8mm spray nozzle for spraying latex and other thick materials attached.



▪ Viscosity test cup, which enables you to test your paint for thickness before painting.



▪ Flexible extension nozzle, which can be bent at any angle, making it easier to paint horizontal or angled surfaces.

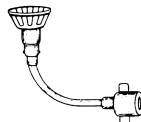

▪ 0.6mm general purpose spray nozzle.

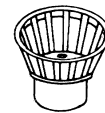

▪ Bottle of Lubricating Oil

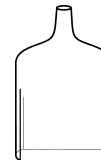

▪ Replacement atomiser valve. Atomiser valves wear with use, this is apparent when the spray pattern changes and atomisation is incomplete. Then it is time to change the atomiser valve.



▪ 1.5m (5') Suction tube for paint cans. For larger jobs, paint can be fed directly from a can using the suction tube. To secure tube onto can use retainer clamp as provided. Hang paint can on a rung with a wire hook if a ladder is used.



## SAFETY OPERATING INSTRUCTIONS



### PLEASE READ BEFORE USE

**NEVER** under any circumstances aim the nozzle at another person or animal. In the event of injury occurring seek expert medical advice immediately.

The spray gun must not be used for spraying flammable paints and solvents with a flash point of less than 32°C.

Always ensure there is adequate ventilation when spraying.

We recommend the use of ear protectors.

We recommend the use of eye protection to keep hazardous vapours out of eyes.

Always wear a mask when spraying.

Always read the paint manufacturers thinning instructions before using.

Always keep the spray basket nozzle in place during use. Never allow the spray to come in direct contact with the skin.

The spray gun must not be cleaned by using flammable liquids with a flash point of less than 32°C.

Hand-arm vibration does exceed 2.5m/s<sup>2</sup>.

**NEVER** spray near a naked flame, including appliance pilot flame.

**NEVER** smoke whilst spraying.

**NEVER** allow children to operate or play with the spray gun.

Before cleaning, always disconnect from the mains supply.

Always disconnect from mains supply when refilling the paint container.

After every use ensure you clean your spray gun thoroughly and **ALWAYS LUBRICATE THE PISTON.**

It is recommended that a RCD (residual current device) rated at 30mA is fitted into the mains supply socket for added protection against electric shock.

**NEVER USE THE SPRAY GUN OUTSIDE WHEN IT IS RAINING.**

### PLEASE NOTE

We have done all we can to ensure that used correctly and according to these instructions, the Earlex SG85 Electric Airless Spray Gun will give long trouble free service. We accept no responsibility for damage caused by the use of incorrect or unsuitable substances, paint or fluids which have not been thinned correctly or are unsuitable for the surfaces to which they are applied, health hazards arising from lack of ventilation when working in confined spaces, or failure of the equipment due to inadequate cleaning of components after use.

If in doubt, always test a small inconspicuous area first. Always read the paint manufacturers instructions first.

Neither our guarantee nor the above statement affect your statutory rights.

## TECHNICAL SPECIFICATION

<b>Power Supply</b>	230V 50Hz-AC
<b>Rated Input</b>	85 Watts
<b>Pump Output</b>	240g/min(water)
<b>Max. Pressure</b>	142 Bar (2000psi)
<b>Container Capacity</b>	1.0 ltr
<b>Spray Gun weight</b>	1.6 kg
<b>Cable length</b>	2 mtr
<b>Piston Material</b>	Tungsten Carbide
<b>Cylinder Material</b>	Tool Steel

### ABOUT THE SG85.

The SG85 is a highly versatile electric airless spray gun, it can be used with several different spray mediums including varnishes, wood preservatives, enamel paint, oil based paint and water based paints. Airless spraying reduces the mist associated with air spraying and also reduces paint loss. A number of applications can be performed including spraying fences, sheds, boats, furniture, radiators, models, louvre doors etc.

### IMPORTANT- SELECTING PAINT

Although a large number of paints and materials can be sprayed, some cannot. Please check manufacturers recommendation before purchasing paint. **CUPRINOL®** This company's products clearly show which can be sprayed and which are brush only. If the can gives details of 'Airless Spraying' it can be sprayed. If it refers to brush application only it cannot be sprayed.

**IT CANNOT BE USED FOR EXTERIOR TEXTURED WALL PAINTS OR TEXTURED COATINGS. USE OF THESE**

**MATERIALS WILL CAUSE PREMATURE WEAR ON THE PISTON AND WILL VOID YOUR GUARANTEE. TO OBTAIN THE BEST RESULTS FROM YOUR SPRAY GUN PLEASE READ THE INSTRUCTIONS CAREFULLY BEFORE USE.**

Your spray gun is supplied with the following items:

- 2 x 0.8mm and 1 x 0.6mm spray nozzles.
- Viscosity cup for thinning paint.
- Flexible extension nozzle for overhead painting.
- Spare valve x 2.
- Bottle of lubricating oil to lubricate the piston after use.
- 1.5m (5') suction tube, return cup and fitting; for use with paint cans.

### PREPARATION

Surface preparation and paint thinning are the two most important areas to be concerned with to obtain the best results from your spray gun.

Ensure all surfaces are free from dust, dirt and grease.

Masking is important to ensure you do not spray those areas you wish to remain untouched.

Ensure paint is thoroughly mixed.

### THINNING

Thinning is particularly important when spraying. Most paints are supplied ready for brush application and need to be sufficiently diluted for spraying purposes.

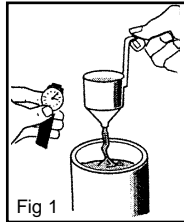

Follow the manufacturers guide for thinning inconjunction with a spray gun. If in doubt please consult the manufacturer of the paint. The viscosity cup supplied will help you determine the correct thickness of the paint.

As some paints, wood preservatives and other sprayable materials contain particles and have different qualities, please ensure that when filling the paint container on your SG85, the paint is filtered through either a funnel with a filter on it, or through nylon tights or stockings. This will ensure no large particles enter the paint container, so preventing blockages and providing you with trouble free spraying. Ensure that a face mask, gloves, goggles and ear protectors are worn at all times when spraying.

**IDEAL VISCOSITY**

<b>Water based paints</b>	35-45secs
<b>Oil Based paints</b>	15-25secs
<b>Enamel paints</b>	15-25secs
<b>Wood preservatives</b>	no dilution
<b>Primers</b>	20-30secs
<b>Varnishes</b>	20-25secs
<b>Aluminium paints</b>	15-25secs
<b>Wood stains</b>	no dilution
<b>Latex Emulsions</b>	*10-20% dilution
<b>Smooth Masonry Paint (non grit)</b>	*5-10% dilution

\* These paints cannot be measured in the viscosity cup. To spray them, remove the filter from the suction tube, thin according to manufacturer's recommendations and strain to remove any lumps or particles.

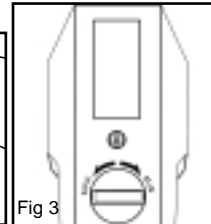
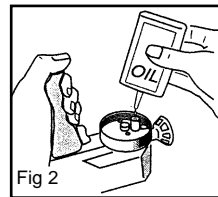

Dip the viscosity cup into the material and fill up. Time how long it takes the viscosity cup to empty (fig 1). Using the above chart as a guide to determine if the material requires further thinning, thin accordingly.

**OPERATION**

Turn the gun upside down and place a few drops of lubricating oil in both the apertures on the underside of the gun (see fig 2). Momentarily trigger the spray gun to disperse the oil around the piston and cylinder, then firmly push the filter suction tube into the tapered hole of the raised boss.

Fill the container with the paint, when filling the paint container, filter the paint through a piece of nylon stocking or a funnel which incorporates a filter to remove any lumps or particles. **DO NOT OVERFILL.** Screw the spray gun on to the container tightly. Plug in the unit and before you start spraying the object, pull the trigger, aiming the gun at a piece of cardboard or newspaper until the paint comes out.

Adjust the output control knob on the back of the gun to control the volume of paint that you wish to apply (fig 3). This will also affect the spray pattern. A poor spray pattern will concentrate the paint in the centre of the spray and give a blotchy finish. A good spray pattern is achieved when there is an even amount of material in a fine spray throughout the pattern.

### USING THE OUTPUT CONTROL KNOB

Turning the output control knob clockwise reduces the flow of material whilst turning it anti-clockwise increases the flow. To adjust the pattern undertake the following:

1. Turn the knob anti-clockwise to the maximum position.
2. Pull the trigger and test the pattern on a piece of cardboard or newspaper.
3. Turn the output control knob clockwise until the spray pattern is correct.

If you have undertaken the above and you still cannot obtain a good spray pattern then the material being sprayed probably requires further thinning.

### MASK ANY AREAS YOU DO NOT WISH TO BE SPRAYED.

### SPRAYING TECHNIQUE

1. To obtain the best results always keep your spray gun level and spray equally from side to side or

up or down 25-30cm (10"-12") from the surface. Avoid spraying at an angle as this will lead to runs on the surface (fig 4).

2. Let your arm control the left to right movement rather than your wrist as this will aid even paint distribution over the whole area (fig 4).

3. Do not tip the sprayer to more than 45° angle. Material could flow into the motor housing and damage the sprayer.

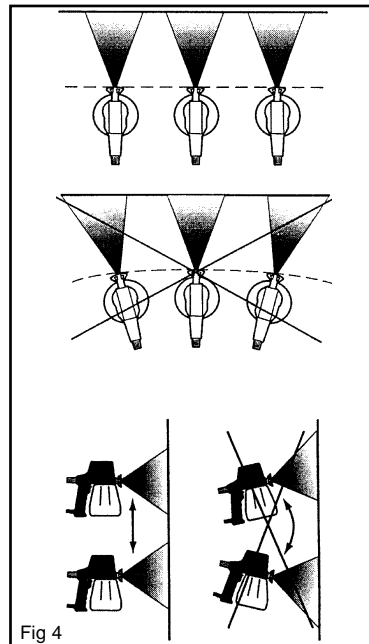

Fig 4

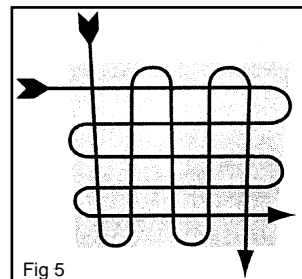

Fig 5

## HELPFUL HINTS

1. Evenly control the speed of movement of the spray gun. A fast speed will give a thin coat and a slow speed will give a heavy coat.
2. Only apply one coat at a time. If a further coat is required follow the paint manufacturers instructions for drying times.
3. If spraying small areas or objects keep the output setting low as this will avoid excessive use of paints and will minimise overspray.
4. When spraying large areas or objects, it is best to use a criss-cross pattern, either from left to right then up or down or vice-versa. This will ensure maximum coverage (fig 5).
5. Avoid stopping and starting when spraying as this can lead to too much or not enough material on a surface.
6. To ensure edges are covered, commence spraying just to the side of area being sprayed, continue and do not stop until the spray has gone past the opposite edge.

## SPRAY NOZZLE SELECTION

Two nozzle sizes are supplied with the gun, these should be used as follows:

- 1) 0.6mm - This size works best for oil-based materials, stains, sealers, lacquers, water-proofers and enamels for small application areas.
- 2) 0.8mm - This is a general purpose nozzle that works best for materials such as emulsions, latex and thicker type paints.

- 3) If you start spraying and find that the spray pattern is small and splattery and adjusting the output control knob does not solve the problem then you need to try the larger nozzle before further thinning the material.

## USING THE FLEXIBLE EXTENSION NOZZLE

The flexible extension nozzle can be bent at any angle to make the painting of ceilings and floors much

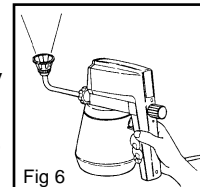

easier. As the sprayer must not be tilted at more than a 45° angle to prevent a back leak, it is essential to use the flexible extension to paint ceilings (fig 6).

To use this, operate as follows:

- 1) Unscrew the spray gun nozzle by turning it anti-clockwise. Be sure to leave the valve in place but check for wear.
- 2) Screw the end of the extension tube with the plastic thread onto the spray gun.
- 3) Ensure the short atomiser valve is inserted into the flexible extension tube.

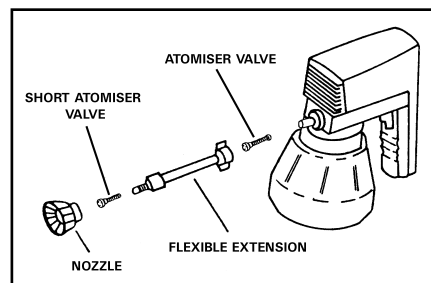

- 4) Screw the spray nozzle onto the end of the flexible extension.
- 5) Bend the flexible extension to the required shape. Once bent do not straighten.
- 6) When finished using, clean all parts and then re-assemble in the original configuration.

**CLEAN AFTER EVERY USE  
(SEE CLEANING INSTRUCTIONS)**

### **HOW TO USE THE 1.5m (5') SUCTION TUBE**

For larger painting applications, using the 1.5m (5') suction tube enables you to draw paint directly out of a large can instead of using the paint container, thus saving considerable time and making painting an even easier job, since you are operating the sprayer without a loaded paint container.

#### **Assembling the 1.5m (5') Suction Tube:**

1. Remove the paint container and the intake tube from the paint sprayer.
2. Insert the adapter fitting through the hole in the return cup into the paint intake port on the sprayer-ensure this is firmly pushed in. (Same position as where the suction tube was removed from).
3. Locate the return cup within the recess where the paint container was located. Slip the retainer nut over cup and screw into place firmly. (The return cup is necessary to catch any paint that is returned through the overflow bypass opening below the paint pump).
4. Insert 1.5m (5') intake suction tube into adapter fitting up to the stop. Insert other end of flexible tube

over suction tube filter moulding, ensure this fits tightly to prevent air leaks, immerse filter end of suction tube into paint can and secure tube to can using the retainer clamp.

5. To reduce the time the sprayer runs without paint, hold the sprayer below the paint level when priming the sprayer, this speeds up the time the paint takes to draw through the tube. The paint may need additional thinning if you still experience difficulty priming the sprayer. The paint must be stirred fully before use.

6. When using the spray gun with the 1.5 suction tube only use the gun in normal upright position, support or hang the gun in an upright position during breaks of use.

If the gun is not kept in the normal upright position after use, remove the cup and drain the fluids before placing down on it's side.

Observe the fluid level in the return cup, empty before it is completely full.

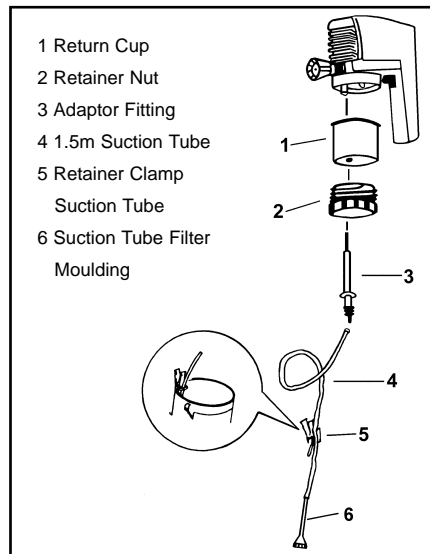



## PRIMING THE SPRAYER

If you are using the suction tube, you will need to prime the sprayer by removing air from the system. To prime:

1. Turn the flow knob fully counterclockwise to maximum.
2. Make certain the sprayer is plugged in.
3. Hold the sprayer below the level of paint. This will speed the priming.
4. Squeeze the trigger and hold until all air is out of the system and material is flowing freely out of the sprayer tip. This should take about two minutes.

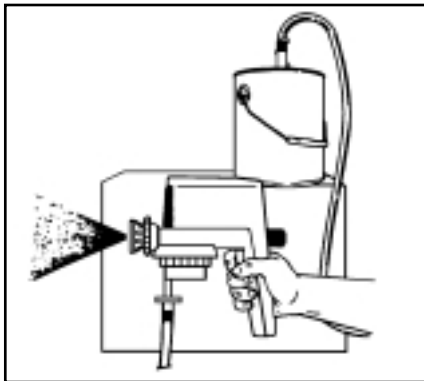

**WARNING-** The filter must be completely submerged in the paint at all times. If not completely submerged and air is sucked into the system, the piston could seize. If the piston seizes, the sound the gun makes will change to a low hum and the gun will quickly become hot. Stop using immediately. Clean and lubricate gun thoroughly before re-using.

## CLEANING

Run solvent through the tube until it is clean. Then disassemble the fittings at both ends before any remaining paint dries up, thoroughly clean the adaptor fitting, intake tube and filter. Also remove the return cup and clean with an appropriate solvent.

## CLEANING INSTRUCTIONS

After every use it is essential that you clean the gun thoroughly. This will prevent any blockages occurring and provide constant performance when you next come to use it.

When you have finished spraying, empty any remaining material out of the paint container.

Rinse the spray gun container with the thinner that was used and spray through the gun onto cardboard or newspaper.

**REMEMBER-USE SUITABLE THINNERS WITH A FLASH POINT OF 32°C MINIMUM. ENSURE ADEQUATE VENTILATION AND DO NOT SPRAY NEAR NAKED FLAMES.**

Pour some more of the thinner that was previously used into the container and spray the gun until what is being sprayed becomes clear.

Wipe the nozzle and paint filter then clear any remaining debris. Finally turn the gun upside down and apply a few drops of the lubricating oil to the piston (fig 8).

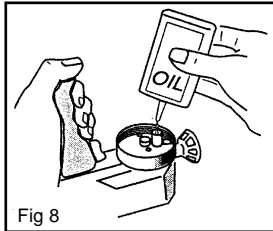

Fig 8

Momentarily trigger the spray gun to disperse the oil around the piston and cylinder.

### LONG TERM CLEAN-UP

If the spray gun is being stored for a period of time the following should also be undertaken in addition to the above cleaning instructions:

- 1) Ensure the spray gun is unplugged.
- 2) Remove paint container and pull out the suction tube.
- 3) Unscrew the 4 mounting screws on the underside of the cylinder housing.
- 4) Remove container cover and cylinder housing from the motor housing.
- 5) Remove the piston and spring, thoroughly clean with the appropriate thinner.
- 6) Remove the spray nozzle by turning anti-clockwise.
- 7) Pull out the valve, making sure that this is not 'stretched' during removal or lost.
- 8) Clean all parts thoroughly.
- 9) Lubricate with oil.
- 10) Re-assemble in reverse order.  
See fig 9.

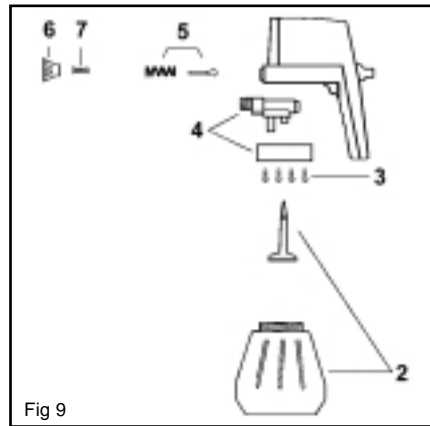

Fig 9

### MAINTENANCE AND REPAIR

Please be aware that certain parts of this spray gun will wear, requiring replacement and that these parts are not covered by guarantee. These parts include the valve, spray nozzle, piston and spring. The wear on these parts depends on the abrasiveness of the materials being sprayed. More abrasive materials such as latex paint (emulsions) will cause these parts to wear much faster. You would normally expect to replace an atomiser valve after spraying between 25-45 litres of latex. If you check the face of a new valve you will see the size of the 3 holes and the smoothness of the bumpers.

Worn valves will have larger holes and scratches on the surface. This will cause a poor spray pattern and will require replacing. Replacement valves are available from the Earlex Service Department.

You will need to check the spray nozzles, piston and spring from time to time to check for wear and replace if necessary.

**NEVER DISPOSE OF PAINTS OR SOLVENTS INTO DRAINS. CONTACT YOUR LOCAL COUNCIL TO ARRANGE COLLECTION.**

## MAINS CONNECTION

### **WARNING - THIS APPLIANCE MUST BE EARTHED**

Your unit will have been supplied with a mains lead with a fitted moulded plug. This is identified by the fuse holder in the base of the plug. Please read the following safety instructions before use.

1 If the moulded plug is cut off from the mains lead then the plug must be disposed of safely.

**NEVER** under any circumstances insert such a plug into a 13 amp socket.

2 **NEVER** under any circumstances use the appliance without the fuse cover fitted. This is the little cover fixed into the base of the plug to hold the fuse in place.

3 If you lose the fuse cover then please contact any electrical dealer for a replacement or ring our helpline.

4 A replacement fuse must be rated at 5amp. The fuse must be manufactured and approved to BS1362.

### **5 IF IN ANY DOUBT PLEASE CONSULT AN ELECTRICIAN.**

If you need to fit a plug to the mains lead, this should be done in accordance with the wiring instructions on the mains lead, and will need to be fitted with a 5 amp fuse. If in doubt please consult an electrician.

**WARNING-**If you are using an extension lead, it must be rated at a minimum of 6 amps and fully unwound. Do not operate with a lead rated at less than 6 amps as this will cause premature failure of the motor and will void your guarantee.

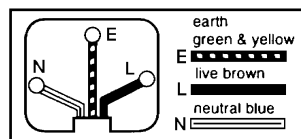

## TROUBLE SHOOTING

PROBLEM	CAUSE	ACTION REQUIRED
Spray Gun HUMS but does not operate.	Piston Sticking. Part no. SG12.	Remove 4 screws adjacent to paint pick up pipe part no. SG14. Release container cover, cylinder housing and piston assembly. Unscrew and remove nozzle. Remove atomiser valve. Use soft punch or shaft of 4.5mm MAXIMUM diameter inserted into the valve housing to eject the stuck piston. Clean and lubricate piston and cylinder. Re-assemble carefully in reverse order. Remember to replace the compression spring onto the piston before fitting the piston. Ensure you have not dropped any parts into the motor housing.
No suction Feed.	No Valve in pump. Paint Pickup filter blocked. Liquid too thick.	Insert atomiser valve part no. SG03. Clean filter accordingly part no. SG16.  Thin liquid as recommended.
Spray Gun motor operates but nothing coming out.	Nozzle Blocked part no. SG04 or SG44. Atomiser valve blocked, part no. SG03.	Clean thoroughly with thinners.  Clean thoroughly with thinners.
Spray Gun motor operates, but spluttering.	Worn valve. Worn nozzle. Container almost empty. Spray gun held at wrong angle. Liquid too thick. Incorrectly set regulation control.	Replace atomiser valve part no. SG03. Replace nozzle part no. SG04 or SG44. Refill container.  Hold at correct angle.  Thin liquid as recommended. Adjust regulator at back of gun.
Paint Dripping.	Nozzle loose. Operating at more than 45° angle.	Tighten nozzle. Keep sprayer upright.
Excessive fogging.	Pressure too high. Holding sprayer too far from surface.	Turn output knob clockwise to reduce pressure Hold sprayer about 30cm (12") from work.
Runs and sags in paint.	Arm movement too slow. Spray gun too close to work surface. Applying too much paint in one go.	See section on spraying.

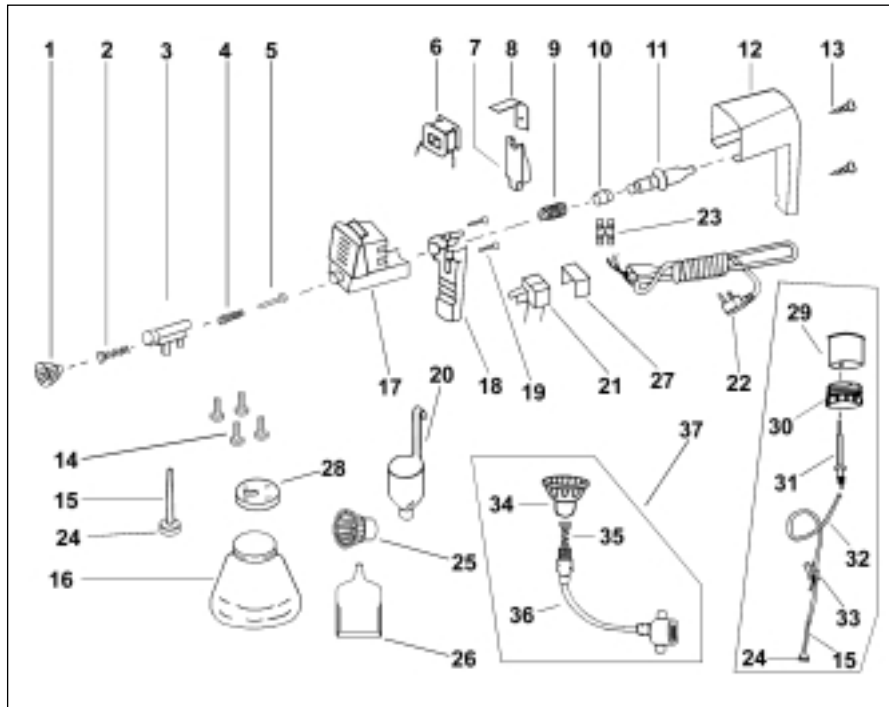

**Parts and Accessories**

1. Spray Nozzle 0.8mm	SG44
2. Atomiser Valve	SG03
3. Cylinder Housing	SG67
4. Piston Spring	SG47
5. Piston	SG69
6. Coil	SG70
7. Armature	SG57
8. Leaf Spring	SG58
9. Control Spring	SG71
10. Rubber Buffer	SG60
11. Output Knob	SG72
12. Cover	SG77
13. Cover Screw	SG63
14. Screw (C/Housing)	SG14
15. Suction Tube	SG15
16. Container	SG74
17. Drive Housing with Stator	SG76
18. Handle	SG77
19. Handle Screw	SG78

20. Viscosity Cup	SG18
21. Switch	SG43
22. Mains Lead with plug	SG79
23. Terminal Block	SG89
24. Filter	SG16
25. Spray Nozzle 0.6mm	SG04
26. Lubricating Oil	SG19
27. Switch Cover	SG80
28. Container Cover	SG81
<hr/>	
29. Return Cup	SG83
30. Retainer Nut	SG84
31. Adaptor Fitting	SG86
32. 1.5m Suction Tube	SG87
33. Retainer Clamp	SG88
<hr/>	
34. Spray Nozzle 0.8mm	SG44
35. Short Atomiser Valve	SG51
36. Flexible Attachment	SG91
37. Flexible Nozzle Assy	SG50

### **OTHER PRODUCTS FROM EARLEX.**

Earlex also manufacture a wide range of steam wallpaper strippers. Designed to remove all types of wallpaper, multi-layered papers and artex.

#### **SS100 - 2300W 4.5 ltr steam wallpaper stripper.**

#### **SS50 - 2000W 4.5 ltr steam wallpaper stripper.**

A range of steam cleaning accessories are also available to be used in conjunction with the steam wallpaper strippers. The accessories can be used to clean and rejuvenate carpets, floor tiles, unblock sinks or waste outlets, clean work surfaces, defrost fridges and freezers, clean windows and tiles, remove soiling from upholstery and curtains.

Alternatively the **Steama-Plus** combines the versatility of the steam wallpaper stripper with a selected range of the accessories providing you with a complete steam cleaning kit and wallpaper stripper.

**SC165 - 1500W 4.5 ltr steam cleaning kit:** incl. carpet cleaner, window/tile cleaner, jet nozzle cleaner, upholstery cleaner/small steamplate, large wallpaper stripping plate.

**PR9 -The Autofeed Paint Roller** is a portable battery operated paint rolling system. It has a 3 litre paint reservoir and 23cm (9") roller and automatically feeds the paint to the roller head. No trays need to be refilled or moved. Easy to use the PR9 provides enough capacity for one coat of a 3.6m x 2.7m (12'x 9') room without having to refill.

**WD1000 - Combivac Wet 'n' Dry Vacuum & Blower.** The 1000W motor provides a powerful suction and blowing facility which is ideal for use around the workshop, garage, caravan, car, garden and home. The 20 litre recovery tank has 12 litres wet capacity and is designed for the rough and tumble of every day use. The Combivac has on board storage facilities for its accessories, 6 metres of working length and a two year guarantee. There is also a variety of additional accessories available for use with the Combivac.

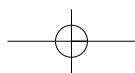
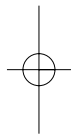
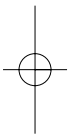
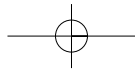

**GUARANTEE**

This product is guaranteed for a period of 12 months against faulty manufacture or materials it is not guaranteed for industrial or hire purposes. This guarantee does not affect your statutory rights. In the event of any problem occurring please contact us on our Helpline no

**01483-454666**

EC Declaration of Conformity

We declare that the units: SG85 conform to: 73/23/EEC, 89/336/EEC, EN61000-3-2 & EN61000-3-3, EN55014, EN55014-2



Tim Hopper-Technical director



Earlex Ltd.,  
Moorfield Road, Slyfield Industrial Estate,  
Guildford, Surrey, GU1 1RU.  
Tel: 01483-454666. Fax: 01483-454548  
email:enquiries@earlex.co.uk

SG82 08/98



## Free Manuals Download Website

<http://myh66.com>

<http://usermanuals.us>

<http://www.somanuals.com>

<http://www.4manuals.cc>

<http://www.manual-lib.com>

<http://www.404manual.com>

<http://www.luxmanual.com>

<http://aubethermostatmanual.com>

Golf course search by state

<http://golfingnear.com>

Email search by domain

<http://emailbydomain.com>

Auto manuals search

<http://auto.somanuals.com>

TV manuals search

<http://tv.somanuals.com>