

# GENICOM microLaser 210 User Guide

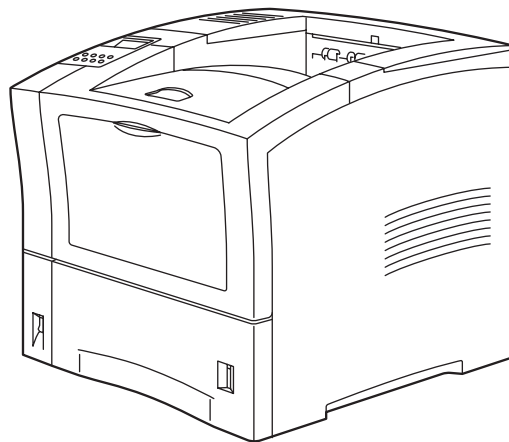

## Trademarks

The following are trademarks or registered trademarks of their respective owners. Other product names mentioned in this manual may also be trademarks or registered trademarks of their respective owners. Registered trademarks are registered in the United States Patent and Trademark Office; some trademarks may also be registered in other countries. GENICOM, the GENICOM logo, are registered trademarks of GENICOM. PostScript is a trademark of Adobe Systems Incorporated for a page description language and may be registered in certain jurisdictions.

## Proprietary Statement

The digitally encoded software included with your microLaser 210 is Copyrighted © 2000 by GENICOM. All Rights Reserved. This software may not be reproduced, modified, displayed, transferred, or copied in any form or in any manner or on any media, in whole or in part, without the express written permission of GENICOM.

## Copyright Notice

This manual is Copyrighted © 2000 by GENICOM, 14800 Conference Center Drive, Suite 400, Chantilly, VA 20151-3820. All Rights Reserved. This manual may not be copied in whole or in part, nor transferred to any other media or language, without the express written permission of GENICOM.

The specifications of your printer and the content of this publication are subject to change without prior notice. Every attempt has been made to verify the accuracy of the content herein. Should you wish to report comments or suggestions regarding this publication, feel free to contact:

GENICOM Corporation  
ATTN: Nonimpact Technical Publications  
900 Clopper Road, Suite 110  
Gaithersburg, MD 20878





# Contents

---

## Preface 1

### About this Manual 2

Scope 2

Overview 2

Printer Orientation 3

Conventions 3

### About the Printer 5

Features 5

Available Configurations 6

---

## Chapter 1 Getting Started 1-1

### Safety Precautions 1-2

Handling the Printer 1-2

### Package Contents 1-2

CD-ROM Contents 1-3

### Printer Location Requirements 1-3

Printer Weight and Dimensions 1-3

Space Requirements 1-4

Environment 1-5

**Parts of the Printer 1-6**  
**Optional Printer Accessories 1-9**  
**Paper Path 1-9**

---

## **Chapter 2      Using the Printer 2-1**

**Connecting the Printer to the AC Outlet 2-2**  
**Turning Power On and Off 2-3**  
**Connecting the Printer to the Host Computer 2-4**  
    **Parallel Port 2-4**  
    **USB Port 2-5**  
**Selecting Print Media 2-8**  
    **Paper and Print Media To Avoid 2-8**  
    **Correct Paper Storage 2-9**  
    **Print Media Capacities 2-9**  
    **Print Media Weight, Type, and Size 2-11**  
**Loading the Universal Paper Tray 2-11**  
**Loading the Front Tray 2-15**

---

## **Chapter 3      Understanding and Navigating the Control Panel Menus 3-1**

**Control Panel Features 3-2**  
    **LCD Display 3-2**  
    **LED Indicators 3-3**  
    **Pushbuttons 3-3**

**Navigating the Control Panel Menus 3-4**

**Menu Structure 3-6**

**Paper Menu 3-7**

**Interface Menu 3-9**

**PS Menu 3-10**

**PCL Menu 3-11**

**System Menu 3-13**

**Quality Menu 3-15**

**Functions Menu 3-16**

**Status Menu 3-17**

---

## **Chapter 4      Maintaining the Printer 4-1**

**Upgrading Printer Firmware 4-2**

**Upgrading Firmware Using the Parallel Interface 4-2**

**Upgrading Firmware Using the Network Interface 4-2**

**Replacing Printer Components 4-3**

**Replacing the Toner Cartridge 4-3**

**Replacing the Fuser 4-6**

**Replacing Feed Roll, Nudger Roll, and Retard Roll 4-9**

**Replacing the BTR Roller 4-14**

**Cleaning the Printer 4-17**

**Cleaning the Exterior 4-17**

**Cleaning the Interior 4-19**

**Moving the Printer 4-21**

**Moving the Printer a Short Distance 4-21**

**Moving the Printer a Long Distance 4-21**

**Storing the Printer for Long Periods of Time 4-22**

---

## **Chapter 5      Troubleshooting 5-1**

**Installation Problems 5-2**

**Inoperative Printer 5-3**

**No Ready Message 5-3**

**Noise, Smoke, or Smell 5-3**

**Paper Jams 5-4**

**Clearing an E2 Paper Jam 5-6**

**Clearing an E3 Paper Jam 5-8**

**Clearing an E4 Jam 5-10**

- Clearing an E7 Paper Jam 5-13
- Clearing an E6 Paper Jam 5-16
- Print Image Quality Problems 5-18
  - Other Print Image Quality Problems 5-21
- Miscellaneous Problems 5-22
  - Printer is Inoperative 5-22
  - Printer Operates Erratically 5-23
  - Printer Makes Unusual Noises 5-24
  - Room Lights Dim or Flicker When Printer Starts 5-25
  - Printer Interferes with Nearby Radio or Television Reception 5-25
- Warning Messages and Error Messages 5-26
  - Warning Messages 5-27
  - Error Messages 5-28

---

## **Chapter 6 Using the Duplexer 6-1**

- About the Duplexer 6-2
  - Major Components of the Duplexer 6-2
- Installing the Duplexer 6-2
- Testing the Duplexer 6-4
- Solving Duplexer Problems 6-6
  - Interpreting Duplexer Error Codes 6-6
  - Installation Problems 6-6
  - Clearing Duplex Paper Jams 6-7
  - Correcting Miscellaneous Duplexer Problems 6-10
- Removing the Duplexer 6-13

---

## **Chapter 7 Using the 550 Sheet Feeder 7-1**

- About the 550 Sheet Feeder 7-2
  - Major Components of the 550 Sheet Feeder 7-2
- Installing the 550 Sheet Paper Feeders 7-3
  - Installing One Paper Feeder 7-3
  - Installing Two Paper Feeders 7-6
- Testing the 550 Sheet Feeder 7-11
- Selecting Print Media 7-11
  - Paper and Print Media To Avoid 7-11
  - Correct Paper Storage 7-11
  - Print Media Weight, Type, and Size 7-12

**Loading Print Media 7-12****Loading the A4/Letter/Legal Paper Tray 7-12****Solving 550 Sheet Feeder Problems 7-16****Interpreting Paper Feeder Error Messages 7-17****Installation Problems 7-17****Clearing an E2 Paper Jam 7-18****Correcting Miscellaneous Paper Feeder Problems 7-19****Maintaining the 550 Sheet Feeder 7-21****Replacing Feed Roll, Nudger Roll, and Retard Roll 7-21****Removing the 550 Sheet Feeder 7-26****Moving the 550 Sheet Feeder 7-29****Moving the Printer and 550 Sheet Feeder a Short Distance 7-29****Moving the Printer and 550 Sheet Feeder a Long Distance 7-29**

---

**Chapter 8****Using the Envelope Feeder 8-1****About the Envelope Feeder 8-2****Installing the Envelope Feeder 8-2****Installing the Envelope Feeder 8-2****Testing the Envelope Feeder 8-4****Selecting Print Media 8-4****Paper and Print Media To Avoid 8-5****Correct Paper Storage 8-5****Print Media Weight, Type, and Size 8-5****Loading the Envelope Feeder 8-6****Solving Envelope Feeder Problems 8-7****Envelopes Become Creased when Printing 8-7****Interpreting Envelope Feeder Error Messages 8-10****Correcting Miscellaneous Envelope Feeder Problems 8-10****Maintaining the Envelope Feeder 8-13****Cleaning the Exterior of the Envelope Feeder 8-13****8-13**

---

**Chapter 9****Using the Offset Catch Tray 9-1****About the Offset Catch Tray 9-2****Major Components of the Offset Catch Tray 9-3**

- Installing the Offset Catch Tray 9-3**
- Removing the Offset Catch Tray 9-7**
- Testing the Offset Catch Tray 9-10**
- Solving Offset Catch Tray Problems 9-10**
  - Interpreting Offset Catch Tray Error Messages 9-11**
  - Installation Problems 9-11**
  - Clearing an Offset Catch Tray Paper Jam 9-12**
  - Correcting Miscellaneous Offset Catch Tray Problems 9-13**
- Maintaining the Offset Catch Tray 9-16**
  - Cleaning the Exterior of the Offset Catch Tray 9-16**
- Moving the Offset Catch Tray 9-16**
  - Moving the Offset Catch Tray a Short Distance 9-16**
  - Moving the Offset Catch Tray a Long Distance 9-16**

---

## **Chapter 10 Using the Face Up Tray 10-1**

- About the Face Up Tray 10-2**
  - Major Components of the Face Up Tray 10-2**
- Installing the Face Up Tray 10-3**
- Removing the Face Up Tray 10-6**
- Testing the Face Up Tray 10-9**
- Solving Face Up Tray Problems 10-9**
  - Interpreting Face Up Tray Error Messages 10-10**
  - Installation Problems 10-10**

---

## **Appendix A GENICOM Customer Support and Part Numbers A-1**

- Sources of Support A-2**
  - Your GENICOM Vendor A-2**
  - Your Application Vendor A-2**
  - Internet A-2**
  - GENICOM Technical Support A-2**
  - GENICOM Service A-3**
- GENICOM Worldwide Offices A-3**
- GENICOM Part Numbers A-6**
  - Printers A-6**
  - Paper Handling Options A-6**
  - Network Interfaces A-6**



**DRAM, FLASH SIMM and Hard Disk Drive Options A-7**  
**User Publications A-7**  
**Consumables A-7**

---

**Appendix B      Safety Notes and Regulatory Compliance B-1**

**Safety Notes B-2**

**Regulatory Compliance B-2**

**Safety Compliance B-2**

**EMC Compliance B-3**





# Preface

## In this Chapter . . .

- “Welcome” on page 2
- “About this Manual” on page 2
- “About the Printer” on page 5

## Welcome

Thank you for selecting the GENICOM microLaser 210 laser printer. This User Guide contains important information about the operation and care of your printer. Please read this manual in its entirety and keep it at hand for later reference.

## About this Manual

### Scope

This User Guide contains all of the information necessary to operate and care for your printer and accessories. It is intended to be used with the pictorial unpacking instructions and the Installation Guide, both included in the printer packaging. If you have not already unpacked and installed the printer, please refer to these documents. This guide does not contain instructions for unpacking and installing the printer.

### Overview

This manual contains ten chapters and three appendixes:

#### *Preface*

The Preface contains information about this guide and about the features and available configurations of the printer.

#### *Chapter 1: Getting Started*

This chapter reviews the contents of the printer packaging, explains the parts of the printer, and describes the space and environment requirements of the printer.

#### *Chapter 2: Using the Printer*

This chapter provides information concerning the daily use of the printer, including procedures for connecting the printer and loading print media, and guidelines for selecting print media.

#### *Chapter 3: Understanding and Navigating the Control Panel*

This chapter explains the control panel and its functions, and also demonstrates how to navigate throughout the various menus and submenus that allow you to view and change the printer settings.

#### *Chapter 4: Maintaining the Printer*

This chapter provides information about maintaining your printer. Although the printer requires very little maintenance, with normal daily use you will need to perform some routine maintenance procedures, including replacing consumable items and cleaning the printer. This chapter also contains information about moving and storing the printer.

#### *Chapter 5: Troubleshooting*

This chapter describes the problems that you may encounter when using your printer, and provides procedures for resolving the problems. This chapter also lists the warning and error messages that appear on the control panel display.

#### *Chapter 6: Using the Duplexer*

This chapter provides all of the information necessary to install, use, and maintain the duplexer.

### *Chapter 7: Using the 550-Sheet Feeder*

This chapter provides all of the information necessary to install, use, and maintain the 550-sheet paper feeder option, including procedures for cleaning the feeder and removing paper jams.

### *Chapter 8: Using the Envelope Feeder*

This chapter provides all of the information necessary to install, use, and maintain the envelope feeder, including procedures for removing paper jams.

### *Chapter 9: Using the Offset Catch Tray*

This chapter provides all of the information necessary to install, use, and maintain the offset output tray, including procedures for cleaning and removing paper jams.

### *Chapter 10: Using the Face Up Tray*

This chapter provides all of the information necessary to install, use, and maintain the face up output tray.

### *Appendix A: GENICOM Customer Support and Part Numbers*

This appendix directs you to sources of help and information, and also lists the part numbers for GENICOM microLaser 210 printers, options, and consumables.

### *Appendix B: Safety Notes and Regulatory Compliances]*

This appendix describes cautions to take when installing, transporting, or operating the printer, and also includes the applicable regulatory compliances.

## **Printer Orientation**

Throughout this guide, the four sides of the printer are referred to as front, rear, right, and left. The front of the printer is the side near the control panel, and the rear of the printer is opposite the front. The left and right sides of the printer are defined as the sides to the left and right, respectively, of a person who is facing the front of the printer.

## **Conventions**

The following conventions are used throughout this manual to emphasize certain procedures or information:

---

**NOTE:** A note is a tip or extra information that may be helpful in installing or using the printer.

---



**CAUTION:** A caution message provides information that may help you avoid equipment damage, process failure, or inconvenience. Read all caution messages carefully. GENICOM will not be responsible for damage that results from improper use of the printer.



**WARNING!** A warning message indicates the possibility of personal injury if a specific procedure is not performed exactly as described in the guide. Pay close attention to these sections and read them fully to prevent possible injury. GENICOM will not be responsible for damage that results from improper use of the printer.

## About the Printer

The GENICOM microLaser 210 printer uses a data modulated laser beam and conventional dry-ink xerographic processes to produce images up to 1200dpi resolution at a paper output speed of 21 pages per minute. The printer can accommodate both plain paper and other print media, and feeds paper from either a main 550-sheet paper tray or from the front tray, which is designed to feed special print media such as labels and transparencies.

There are five paper handling options available for the printer, including a Duplexer for two-sided printing, a 550-Sheet Feeder for additional paper capacity or variety, an Envelope Feeder for printing envelopes, a Face Up Tray for additional output options, and an Offset Catch Tray to hold and separate large print jobs. There are also six replaceable components: the Toner Cartridge; the Fuser; and the feed, nudger, retard, and BTR rolls.

You may connect the printer to either a local computer or a computer network system. Application and print driver software on the computer controls image generation and print processing. The computer sends the electronic image to the printer, where the printer turns the electronic image into a black and white printed image.

## Features

Your laser printer has the following features:

- Quality printing at a high speed

The printer has an output of 21 pages per minute with a resolution up to 1200 dpi.

- Flexible use of paper sources and delivery methods

The base configuration of the printer includes one 550-sheet universal paper feeder and a front tray. The paper feeder can be set to any size paper from postcard to 14 inch legal. The tray can be set for print media from index card size to 14 inch legal, and also accommodates envelopes and labels. You may also add the following paper-handling options to the printer: additional 550-sheet Feeders, Envelope Feeder, Duplexer, Offset Catch Tray, and 100-Sheet Face Up Tray.

- Easy operation

The easy-to-read control panel display clearly shows the status of printer operation. Control panel pushbuttons allow you to access and view printer menus, submenus, and status messages.

- Single-element toner cartridge

The integrated toner cartridge contains both the toner and the photosensitive drum in a single housing, making replacement easy and convenient.

- Continuous printing of up to 1750 sheets

The printer can print up to 1050 sheets unattended when the offset catch tray is installed, and can print up to 1750 sheets attended when two 550-sheet feeders are installed and used along with the multi bypass feeder (100 sheets).

- Optional network-readiness

The network configuration of the printer includes an Ethernet Network Interface Card.

## Available Configurations

The microLaser 210 is available in the following configurations:

### *Standard Configuration - microLaser 210*

The printer is available in the following standard configuration for table-top use:

- Memory: 16MB
- Resolutions: 300 x 300 dpi, 600 x 600 dpi, and 1200 x 1200 dpi
- Paper Input: One 550-sheet universal paper tray for A4/Letter/Legal, and one 100-sheet front tray for paper, transparencies, envelopes, and other non-standard print media
- Paper Output: One 500-sheet face-down tray
-





# Chapter 1

## Getting Started

### In this Chapter . . .

- “About this Chapter” on page 1-2
- “Package Contents” on page 1-2
- “Printer Location Requirements” on page 1-3
- “Parts of the Printer” on page 1-6
- “Optional Printer Accessories” on page 1-9
- “Paper Path” on page 1-9

## About this Chapter

This chapter reviews the contents of the printer packaging, explains the parts of the printer, and describes the space and environment requirements of the printer.

## Safety Precautions

This printer is available in either of the following power specifications: 110V and 220V. The specifications that apply to your printer depend on your machine configuration. To prevent fire or shock hazards, connect the power plug only to a properly rated power outlet.

### Handling the Printer

Follow the guidelines below when lifting or moving the printer:

- The printer is very heavy, and should always be lifted by two people. The weight of the printer without paper tray, toner cartridge, and paper is about 51 lbs (23 kg). Never attempt to lift the printer alone.

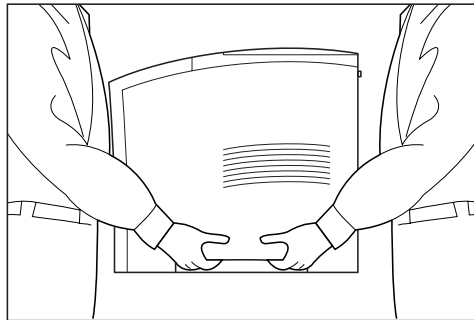

- To lift the printer, have two individuals facing each other from the front and the rear of the printer grasp the recessed areas on each side of the printer. Do not lift the printer by grasping any area other than these recessed areas.
- When lifting the printer, maintain proper lifting posture to prevent injuries.

## Package Contents

Make sure that all of the items shown below are included in the printer packaging. If any items are missing or damaged, contact your dealer.

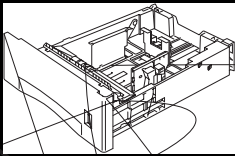

### Space Requirements

A certain amount of space is required for proper operation of the printer and also for performing printer maintenance and replacing consumables. Use the following figures to plan for appropriate clearances when determining a location for your printer.



**CAUTION:** There is a ventilation opening on the left side of the printer. To avoid overheating and fire hazards, be sure to leave a clearance of at least 8 inches (200 mm) between this opening and the nearest wall or other surface.

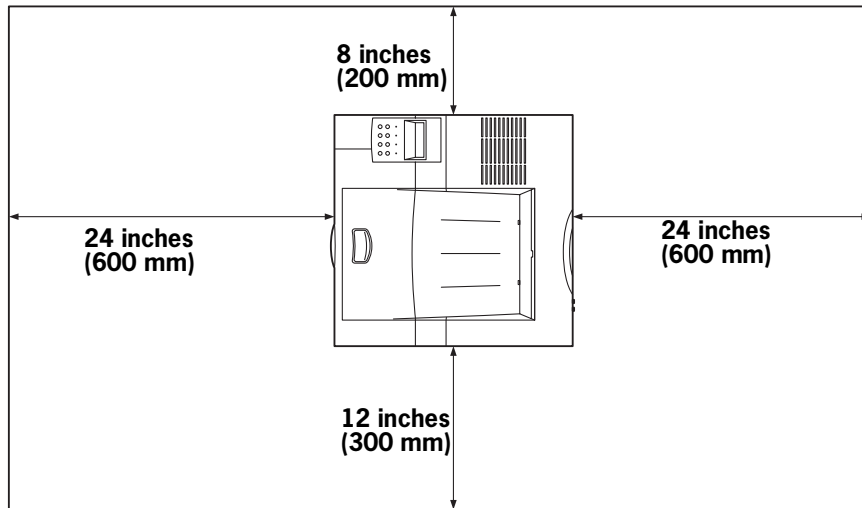

Figure 1-1: Top view of the printer.

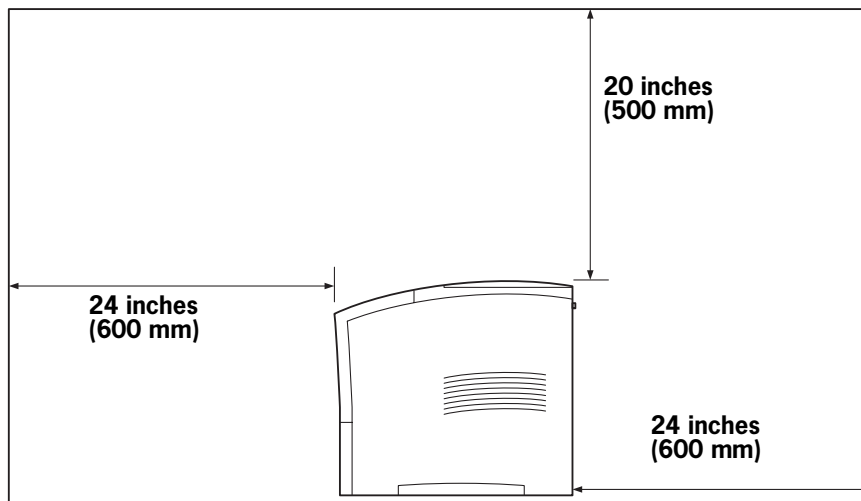
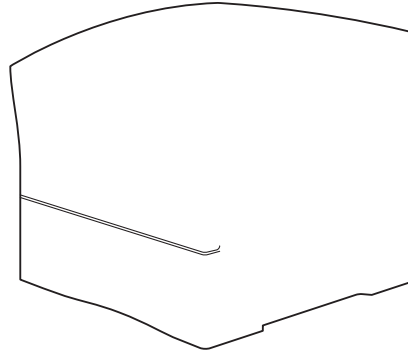

Figure 1-2: Side view of the printer.



## Parts of the Printer

The following figures indicate the names and functions of the main parts of the printer.



**Figure 1-3: Front of the Printer.**

**Figure 1-4: Rear of the Printer.**

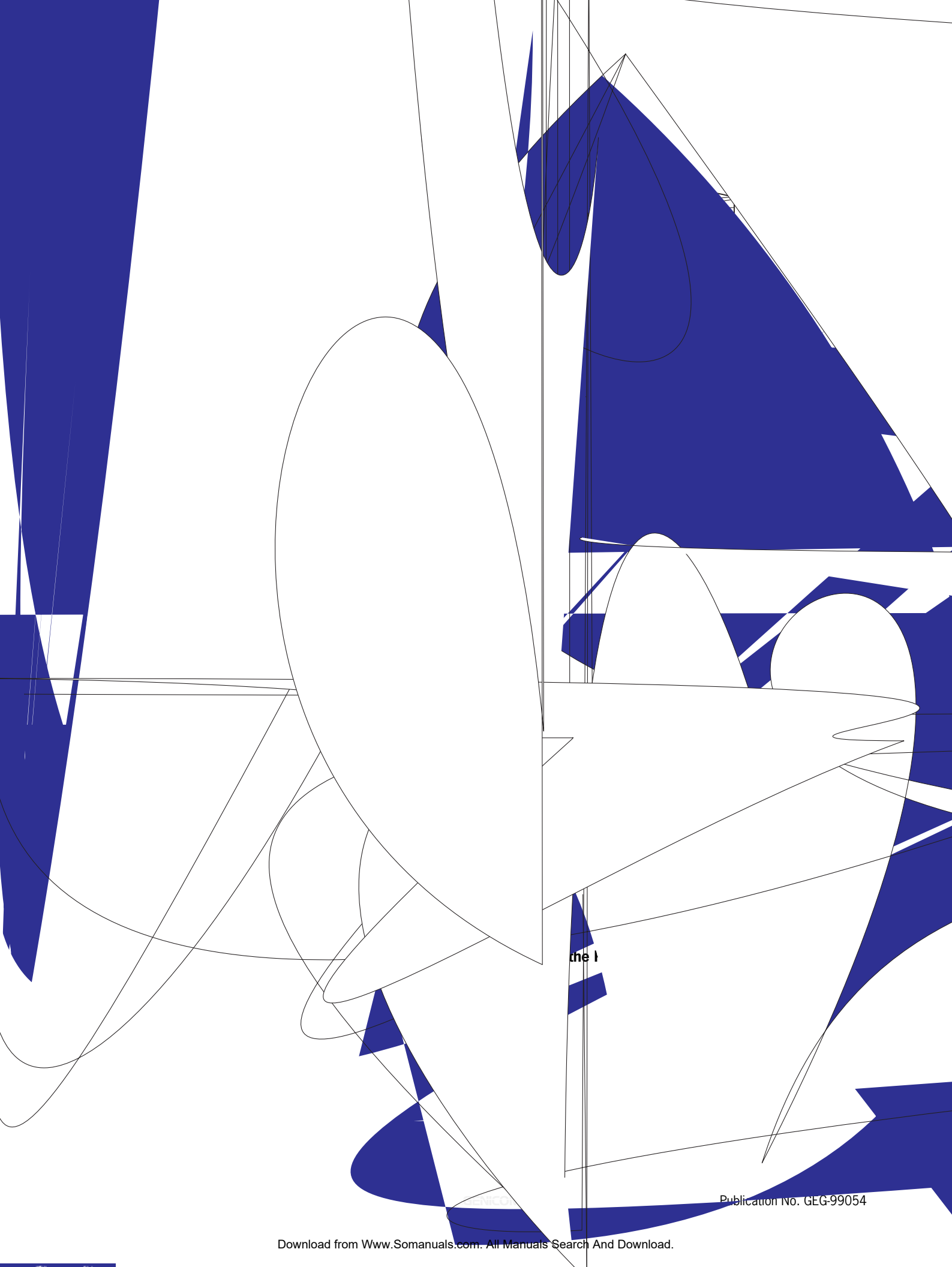

the l

EXNCON

Publication No. GEG-99054

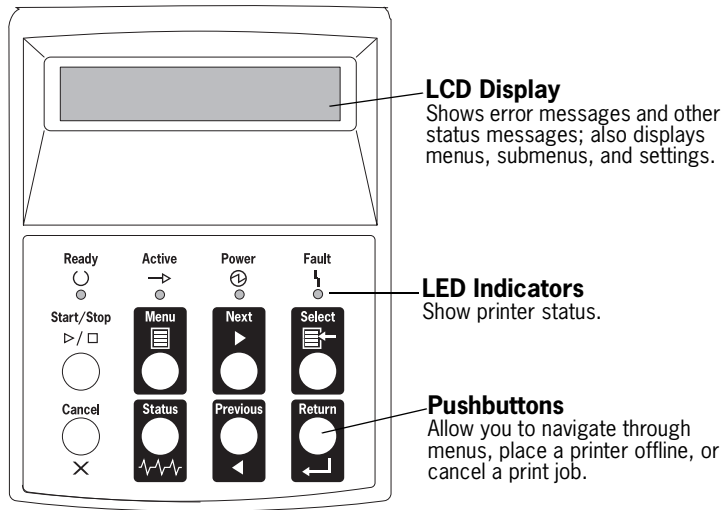
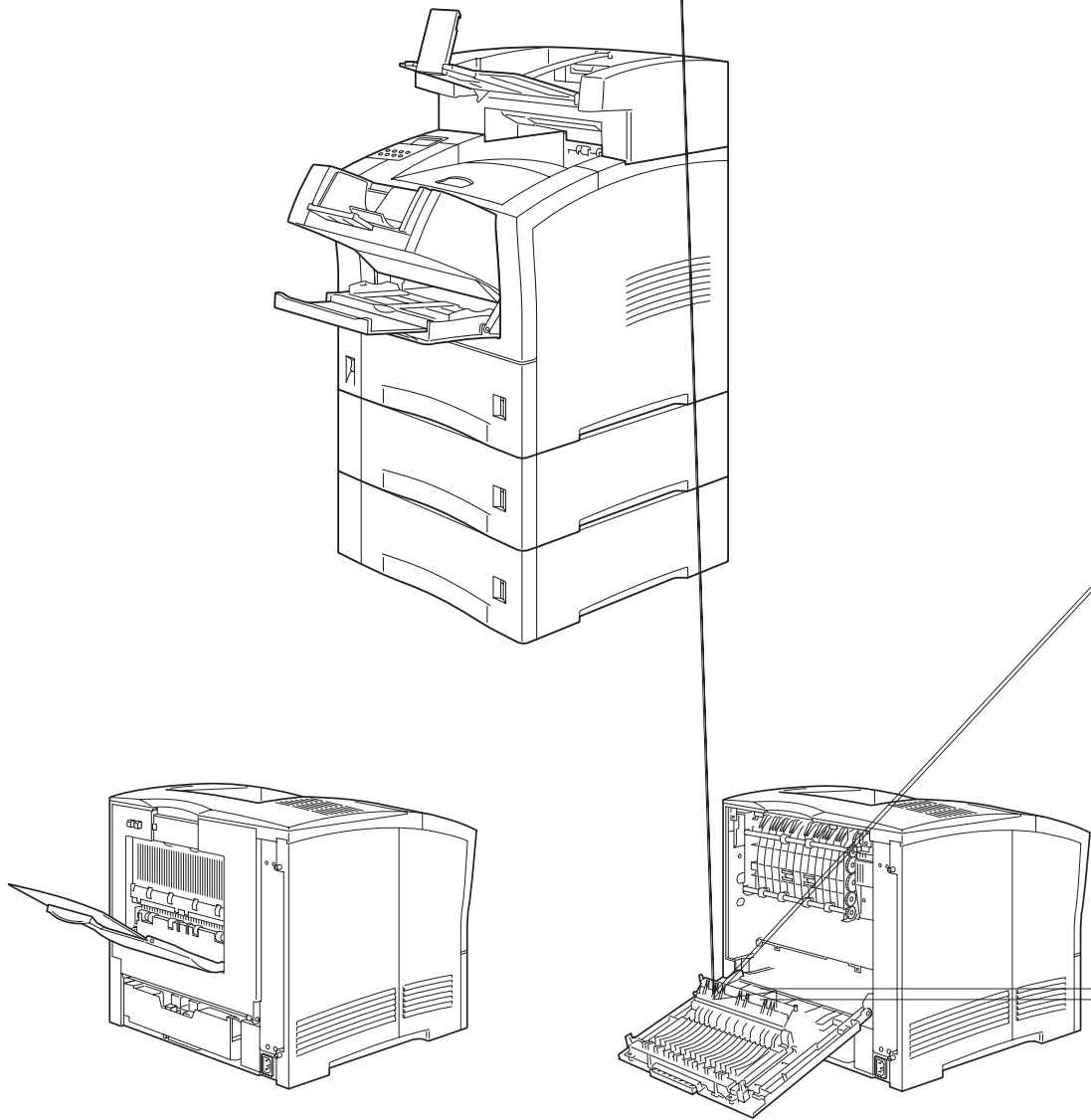

Figure 1-7: Control Panel.



## Optional Printer Accessories

The following figure shows all of the available accessories as installed on the printer:



**Figure 1-8: Optional Accessories.**

## Paper Path

The following figure shows the path that paper travels through the printer:

1. The paper is initially fed from the front paper tray or one of the other paper trays.
2. The image is transferred from the photosensitive drum onto the paper.
3. The fuser fixes the toner permanently on the paper.
4. After passing through the duplexer, if installed, the paper is fed once more through steps (2) and (3).

- The paper emerges onto the output tray, or the offset output tray if installed.

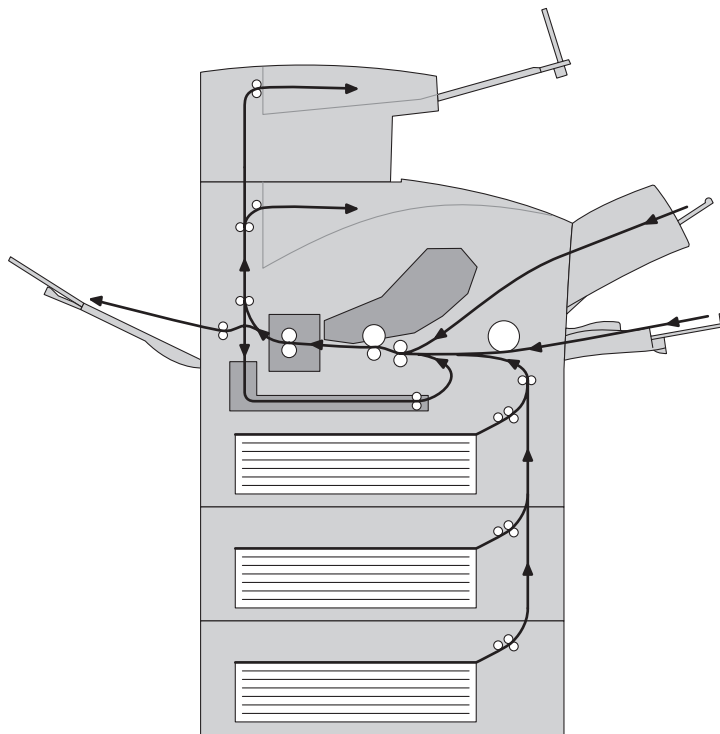

Figure 1-9: Paper Path.



# Chapter 2

## Using the Printer

### In this Chapter . . .

- “About this Chapter” on page 2-2
- “Connecting the Printer to the AC Outlet” on page 2-2
- “Turning Power On and Off” on page 2-3
- “Connecting the Printer to the Host Computer” on page 2-4
- “Selecting Print Media” on page 2-8
- “Loading the Universal Paper Tray” on page 2-11

## About this Chapter

This chapter provides information concerning the daily use of the printer, including procedures for connecting the printer and loading print media, and guidelines for selecting print media.

## Connecting the Printer to the AC Outlet

Use the following procedure to connect the power cord and turn the printer on:

1. Insert the power cord into the AC connector on the rear of the printer.

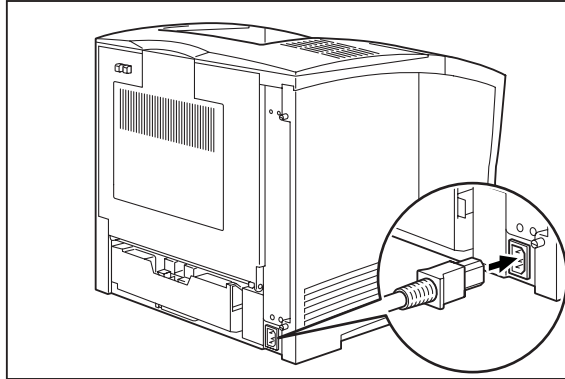

2. Verify that the power switch of the printer is in the [O] (off) position, then insert the plug of the power cord into the AC outlet.

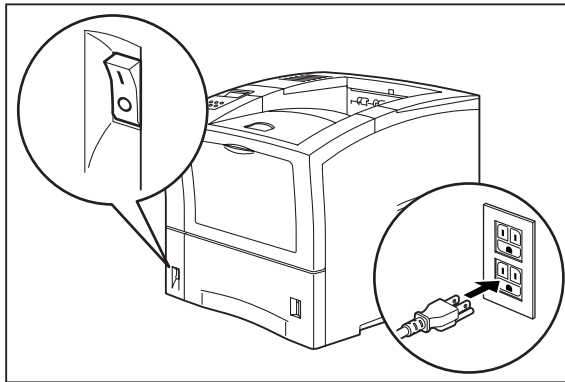

## Turning Power On and Off

Use the following procedure to turn the printer on:

1. Turn the printer on by pressing [ I ] on the power switch on the left front of the printer.

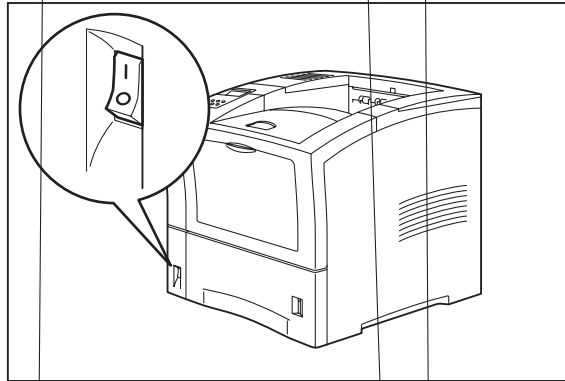

The status message “**Loading**” appears on the display. This message indicates that the printer is warming up and is not ready to print. After about 65 seconds, the status message changes to “**Ready**”, indicating that the printer is ready to print.

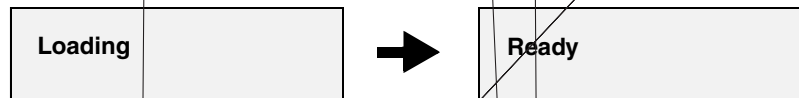

---

**NOTE:** If an error message appears on the display after you turn the printer on, refer to “Warning Messages and Error Messages” on page 32.

---

Use the following procedure to turn the printer off:

1. Turn the printer off by pressing the [ O ] on the power switch on the right side of the printer.

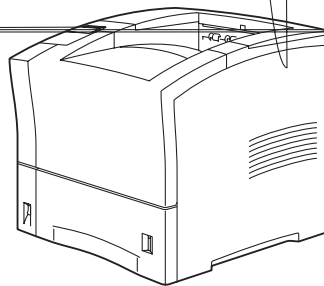

## Connecting the Printer to the Host Computer

You must connect the printer to your computer using an IEEE 1284 parallel cable or a USB cable. These cables are user-supplied, the printer does not include either of these cables. The parallel and USB ports can not be used simultaneously, and the default configuration of your printer has the USB port turned off.

---

**NOTE:** When you turn the USB port on, the parallel port is automatically turned off. When you turn the parallel port on, the USB port is automatically turned off.

---

### Parallel Port

The parallel port is the default port. To connect the printer to your computer using the parallel port, simply connect the parallel cable to the parallel port on the printer, then connect the cable to your computer. Use the following procedure to verify that the parallel port is turned on and to change the parallel port **Interface**, **Format**, and **Mode** settings:

1. Press the **MENU** button on the control panel.
2. Press the **NEXT** button until the text “**Interface Menu**” is shown on the second line of the display.
3. Press the **SELECT** button to enter the interface menu.
4. Press the **NEXT** button until the text “**Port**” is shown on the second line of the display.
  - . Press the **SELECT** button to enter the port submenu.
6. Press the **NEXT** button until the text “**Parallel**” is shown on the second line of the display.
7. Press the **SELECT** button to enter the parallel submenu.
8. Verify that the second line of the display contains the text “**On**”, or press the **NEXT** button until the text “**On**” is shown on the second line of the display.
9. Press the **SELECT** button to change the parallel setting to **On**. After you have pressed the **SELECT** button, the first line of the control panel display should contain the text “**Port**”, and the second line should contain the text “**Parallel**”.
10. Press the **RETURN** button to return to the interface menu. The first line of the display should contain the text “**Interface Menu**”, and the second line should contain the text “**Port**”.
11. Press the **NEXT** button until the text “**Parallel Setup**” is shown on the second line of the display.
12. Press the **SELECT** button to enter the parallel setup submenu.
13. Press the **NEXT** button until the text “**Interpreter**” is shown on the second line of the display.
14. Press the **SELECT** button to enter the interpreter submenu.
  - 1 . Press the **NEXT** button until the desired interpreter is shown on the second line of the display. The available interpreter settings include **Auto Switch**, **PCL**, and **PostScript 3**.
16. Press the **SELECT** button to select the interpreter that you specified in the previous step. After you have pressed the **SELECT** button, the first line of the display should contain the text “**Parallel Setup**”, and the second line should contain the text “**Interpreter**”.
17. Press the **NEXT** button until the text “**Format**” is shown on the second line of the display.

18. Press the **SELECT** button to enter the format submenu.
19. Press the **NEXT** button until the desired format is shown on the second line of the display. The available format settings include **Raw**, **Normal**, and **Binary**.
20. Press the **SELECT** button to select the format that you specified in the previous step. After you have pressed the **SELECT** button, the first line of the display should contain the text “**Parallel Setup**”, and the second line should contain the text “**Format**”.
21. Press the **NEXT** button until the text “**Mode**” is shown on the second line of the display.
22. Press the **SELECT** button to enter the mode submenu.
23. Press the **NEXT** button until the desired mode is shown on the second line of the display. The available mode settings include **Bidirectional** and **Standard**.
24. Press the **SELECT** button to select the mode that you specified in the previous step. After you have pressed the **SELECT** button, the first line of the display should contain the text “**Parallel Setup**”, and the second line should contain the text “**Mode**”.
25. Press the **RETURN** button twice to return to the main menu.
26. Press the **START/STOP** button to exit the menu system.

### **USB Port**

The USB port of your printer provides a reliable, high-speed, bi-directional connection between your printer and PC. The USB standard is designed to deliver complex, graphic-rich documents to the printer with speed and accuracy. USB-enabled printers and PCs allow up to 127 devices to be attached to a single USB port. Fast 12Mbps communication from your PC and printer with absolute reliability.

### *OS Support*

The USB port of your printer supports the following operating system environments:

- **Microsoft Windows 95 and 98 (also known as OSR 2.0, OSR 2.1 and OSR 2. )**  
 If you are using one of these operating systems, your PC may require an optional upgrade to work properly with USB. This upgrade is called USBSUPP.EXE and is provided in the \OTHER\USB directory of your Windows 95 CD-ROM. GENICOM does not supply this update. To find out if your hardware/operating system combination supports USB, run the free program USBREADY.EXE, available from [www.usb.org](http://www.usb.org).
- **Microsoft Windows 98 and 98se**  
 These operating systems come with complete support for USB. You should still run USBREADY.EXE from [www.usb.org](http://www.usb.org) to ensure that the required software and hardware are installed.
- **Apple Mac OS 8.6 and above**  
 This version of Apple's operating system ships with the USB equipped systems and contains the necessary code to support USB. No additional software or hardware should be required.

### *Hardware Support*

The USB port of your printer supports the following hardware:

- **Intel**

Most recent Intel systems will contain the needed components. However, there are a number of older systems that, while having USB hardware, have an obsolete USB implementation. Your GENICOM USB printer will not work with these older systems unless a separate USB controller card is installed in your system. It is possible to have working hardware but not have a physical port, in which case the proper connector must be purchased from the system supplier.

---

**NOTE:** Systems made in 1996 and earlier probably do not support USB correctly on the motherboard; systems made in 1997 may or may not properly support USB; and systems made since 1998 probably do support USB correctly.

---

■ **Apple**

The Apple iMac and G3/G4 systems come with working USB hardware and fully support your GENICOM USB printer. Older PCI-based Macintosh systems may be upgraded with a USB card. This configuration should work with the correct version of the operating system.

*Installation for Windows*

Use the following procedure to install USB for Windows:

1. Verify that your system supports USB and has an available USB connector. If you do not have an available connector, you may need to purchase a USB hub.

---

**NOTE:** You may use an unpowered USB hub, since the printer is considered a self-powered device and will not draw power from the USB port.

---

2. Power on the host system and the printer and allow the two syst3(w)6twoshb2(ho)-7oti1ysng.8(.)TJ/F11 1 T



9. Ensure that the Spooler settings for the printer have "Disable bi-directional support for this printer" checked.
10. Your GENICOM USB printer is now ready to print.

#### *Installation for Mac OS 8.6*

1. Power on the printer and the host computer.
2. Ensure that the "Apple LaserWriter Software" is installed.
3. Attach the USB cable to the host and the printer. Note that the printer is considered a "self powered" device and as such may be plugged into any available USB port on the Macintosh, including the one on the keyboard .

---

**NOTE:** The keyboard USB port on an iMac can only source a minimal amount of power. Plugging a bus-powered device into this port can cause problems because of insufficient power. Since the GENICOM USB Printer draws no power from the bus, it should be possible to use this port without affecting other USB devices.

---

4. Open the "Desktop Printer Utility" (installed when you installed the Apple Laser Writer Software).
  - . Choose the correct driver to use, depending on the printer you are installing.
6. Choose "Printer (USB)" and press "OK".
7. Choose the PPD file that corresponds to your printer.
8. Choose the correct printer.
9. Press "Create".
10. You now have a desktop shortcut to the GENICOM USB printer and are ready to print.

#### *Using the USB Port*

If you would like to use the USB port instead of the parallel port, use the following procedure to turn the USB port on and change the USB interface and format settings on the printer:

1. Press the **MENU** button on the control panel.
2. Press the **NEXT** button until the text "**Interface Menu**" is shown on the second line of the display.
3. Press the **SELECT** button to enter the interface menu.
4. Press the **NEXT** button until the text "**Port**" is shown on the second line of the display.
  - . Press the **SELECT** button to enter the port submenu.
6. Press the **NEXT** button until the text "**USB**" is shown on the second line of the display.
7. Press the **SELECT** button to enter the USB submenu.
8. Press the **NEXT** button until the text "**On**" is shown on the second line of the display.
9. Press the **SELECT** button to change the USB setting to **On**. After you have pressed the **SELECT** button, the first line of the control panel display should contain the text "**Port**", and the second line should contain the text "**USB**".
10. Press the **RETURN** button to return to the interface menu. The first line of the display should contain the text "**Interface Menu**", and the second line should contain the text "**Port**".

11. Press the **NEXT** button until the text “**USB Setup**” is shown on the second line of the display.
12. Press the **SELECT** button to enter the USB setup submenu.
13. Press the **NEXT** button until the text “**Interpreter**” is shown on the second line of the display.
14. Press the **SELECT** button to enter the interpreter submenu.
15. Press the **NEXT** button until the desired interpreter is shown on the second line of the display. The available interpreter settings include **Auto Switch**, **PCL**, and **PostScript 3**.
16. Press the **SELECT** button to select the interpreter that you chose in the previous step. After you have pressed the **SELECT** button, the first line of the display should contain the text “**USB Setup**”, and the second line should contain the text “**Interpreter**”.
17. Press the **NEXT** button until the text “**Format**” is shown on the second line of the display.
18. Press the **SELECT** button to enter the format submenu.
19. Press the **NEXT** button until the desired format is shown on the second line of the display. The available format settings include **Raw**, **Normal**, and **Binary**.
20. Press the **SELECT** button to select the format setting that you specified in the previous step. After you have pressed the **SELECT** button, the first line of the display should contain the text “**USB Setup**”, and the second line should contain the text “**Format**”.
21. Press the **RETURN** button twice to return to the main menu.
22. Press the **START/STOP** button to exit the menu system.

### USB Resources

If you would like more information about USB, refer to the [www.usb.org](http://www.usb.org) website. This organization is responsible for the determining the USB standard and has a number of FAQ's available that should answer most questions.

## Selecting Print Media

Your printer can print on a variety of media, including plain paper, labels, transparencies, and envelopes. Always use print media that meet the guidelines for use with this printer. Print media that is not recommended for use with this printer may cause frequent paper jams or poor print quality.

### Paper and Print Media To Avoid

Do not use paper or print media that has any of the following characteristics:

- Does not meet the paper and media size and weight specifications for this printer
- Is not labeled for use with xerographic printers or xerographic copiers
- Cannot withstand temperatures of up to 310°F/155°C
- Is in a sealed package that is obviously damaged or wet
- Is excessively wrinkled, curled, torn, or warped
- Is folded or creased
- Has either an extremely slick surface or an extremely textured surface
- Has an exposed adhesive surface
- Has paper pieces glued or taped to the media

- Has staples or paperclips attached
- Is categorized as thermal paper, coated paper, or carbon paper
- Is an envelope that is embossed, is made of extremely thick paper, or is padded
- Is an envelope that has metal clasps
- Is an envelope with gummed or adhesive surfaces
- Is a sheet of labels that has the backing sheet exposed between individual labels

### Correct Paper Storage

It is important to store paper correctly prior to placing it in the printer, since improper storage can cause frequent paper jams and poor print quality. Use the following guidelines when storing paper for use in the printer:

- Store reams of paper on a flat surface, and always store them stacked horizontally.
- Store reams of paper in an area away from both direct sunlight and high humidity
- Open sealed reams only when you are ready to load the paper into the paper tray, and always close and seal partial reams of paper.
- Do not stack partial reams of paper.
- Store paper in a dry area, with a temperature of 10 to 30 degrees Celsius and relative humidity of 30% to 60%.

### Print Media Capacities

Your printer can hold up to 1750 sheets of standard weight paper, depending upon the options installed. The printer can be configured in the following three variations:

- Printer (550 sheets)
- Printer with 550 sheet feeder(1100 sheets)
- Printer with two 550 sheet feeders (1650 sheets)

The following table shows the five configurations and the breakdown of paper capacity:

Front Tray (standard)	Tray 1 (standard)	Tray 2 (option)	Tray 3 (option)	Total Paper Capacity
-	550			550
100	550	-	-	650
-	550	550	-	1100
100	550	550	-	1200
-	550	550	550	1,650
100	550	550	550	1,750

If you want to use paper that is an odd size or weight, you must use the front paper tray. The front tray can hold the following quantities of non-standard print media:

- Envelopes : 10

- Transparencies: 30
- Labels: 30
- Standard Paper: 100
- Other paper: Stack Height 11.5mm
- Standard Postcard: 30

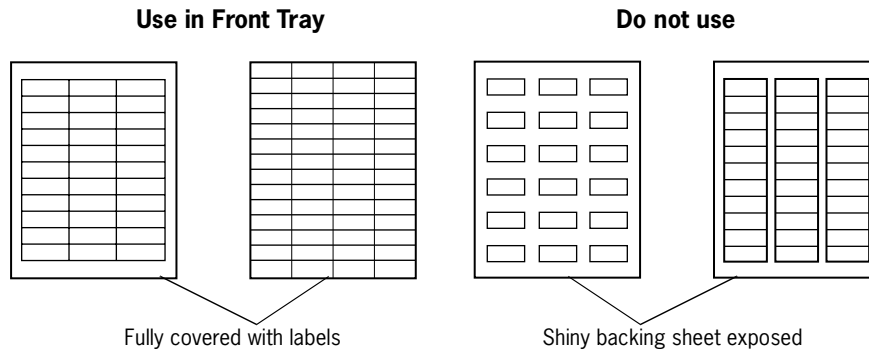

---

**NOTE:** Expect a slight reduction in image quality when you print on envelopes, labels, transparencies, or postcards.

---

### Print Media Weight, Type, and Size

The following table defines print media that you can use in each of the paper sources, and also indicates the feed orientation—long edge feed (LEF) or short edge feed (SEF). If you have concerns about a specific brand or type of media, try samples of the media to determine if the resulting printer performance and print quality meet your expectations.

Paper Source	Meter Weight	Paper Type and Feed Direction	Paper Sizes Accommodated
<b>Universal Paper Tray</b> (main tray and optional 550 sheet paper feeder)  Do not use label stock or other special media in the 550 sheet paper tray.	60 to 216g/m <sup>2</sup>	Any paper	<b>Width:</b> 98.4mm to 215.9mm 3.87 to 8.5 inches <b>Length:</b> 148.5mm to 355.6mm 5.85 to 14 inches
		A4 SEF	297 x 210mm 11.7 x 8.27 inches
		Letter SEF	279.4 x 215.9mm 11 x 8.5 inches
		Legal 13 inch	330.2 x 215.9mm 13 x 8.5 inches
		Legal 14 inch	355.6 x 215.9mm 14 x 8.5 inches
		Executive SEF	266.7 x 184.5mm 10.5 x 7.2 inches
		A5 SEF	210 x 149mm 8.27 x 5.9 inches
		B5 SEF	257 x 182mm 10.12 x 7.17 inches
<b>Front Tray</b>	60 to 216g/m <sup>2</sup>	Envelopes Transparencies Labels Postcards Standard Paper (LEF and SEF) Other Paper	<b>Width:</b> 3.0 to 8.5 inches 76.2mm to 215.9mm <b>Length:</b> 5.0 to 14 inches 127mm to 355.6mm

### Loading the Universal Paper Tray

The 550-sheet universal paper tray has two width guides that are located on the sides of the tray, and one length guide that is located near the center of the tray. These guides allow you to adjust the size of the area that holds paper.

---

**NOTE:** The following procedure shows you how to load paper into the main paper tray. To load paper into the optional 550 sheet paper feeder, simply complete the procedure using the 550 sheet paper tray and feeder rather than the main paper tray.

---

Use the following procedure to load paper into the 550 sheet universal paper tray:

1. Place the paper tray on a level surface.

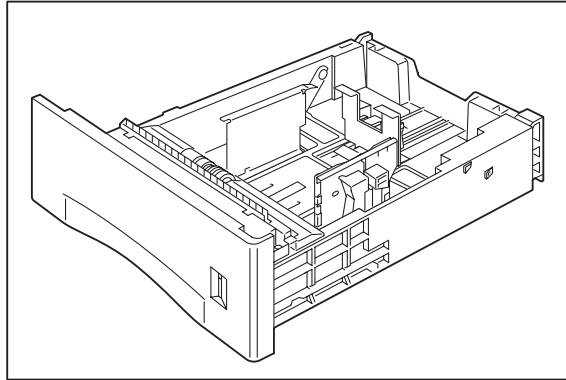

2. Squeeze the length guide, lift it up, and slide it to the rear of the tray.

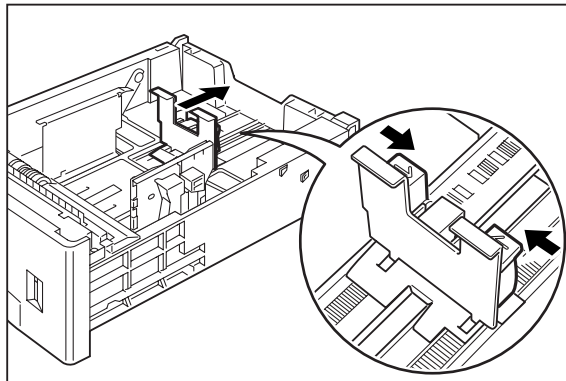

3. If the paper you are using is longer than A4 (297 cm), press the square green button on the bottom of the paper tray to release the rear of the tray, and pull the tray out to extend it.

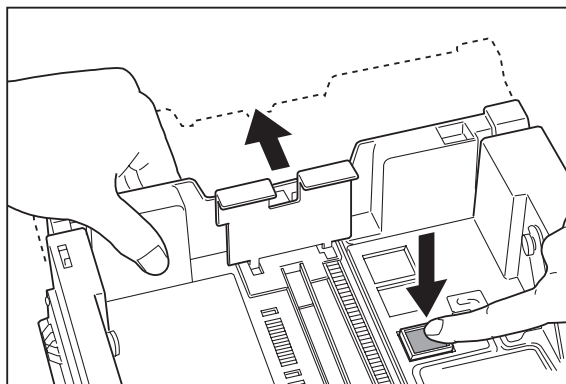

4. Squeeze the right width guide, lift it up, and slide the guides to the sides of the tray.

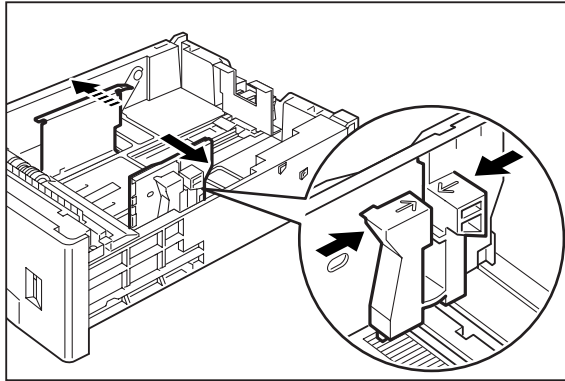

5. Verify that the plate has dropped down into the base of the paper tray. If the tray is locked in the up position, pull the lever near the front of the tray to release the plate, or push the paper tray all the way into the printer and then remove it.

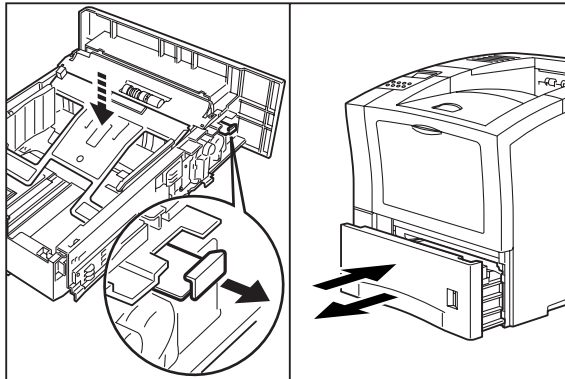

**CAUTION:** Do not overload the tray, and make sure the paper stack is beneath the retaining clips on both sides of the tray. Fan paper before placing it in the tray, and place paper in the tray with the print side up.

6. Align the edges of the paper and place it in the center of the paper tray with the print side down.

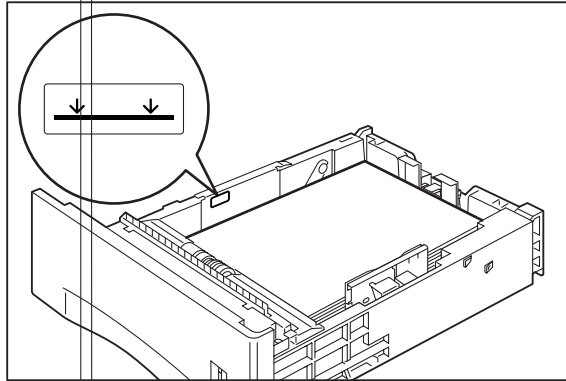

---

**NOTE:** To avoid paper jams and other paper transportation problems, make sure the length guides are adjusted to match the paper size and are locked firmly into place

---

7. Squeeze the right width guide, lift it up, and adjust the guides to match

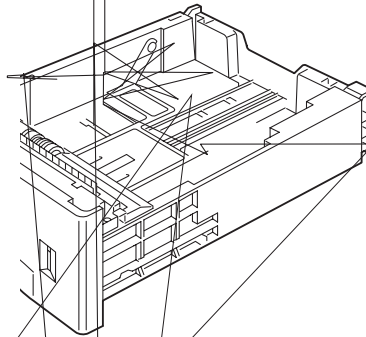

8. Squeeze the length guide, lift it up, and adjust the guides to match the length.



9. Grasp the paper tray with both hands and insert it into the tray well on the printer.

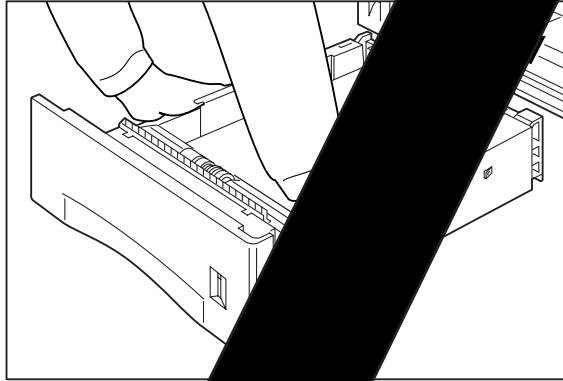

10. Push the paper tray completely into the printer, making sure the tray is properly seated.

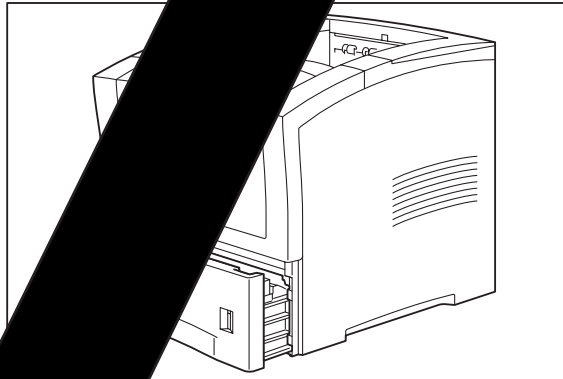

11. Use the paper level sensor on the front right of the printer to determine when the paper supply is low.

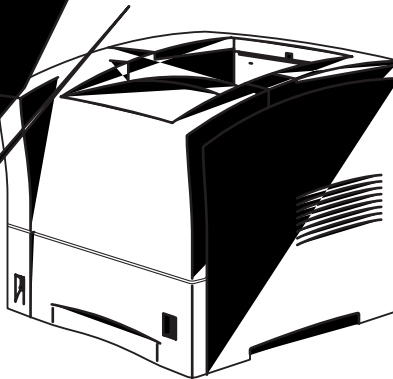

### Loading the Front Tray

The front tray located on the front of the printer can accommodate a maximum of 100 sheets of paper, and can also accommodate a maximum of 30 sheets of standard labels, transparencies, or postcards, and a maximum of 10 standard envelopes. The tray has two guides that are located on the left and right sides of the tray. These guides allow you to adjust the size of the area that holds the print media. Use the following guidelines when loading the front tray:

- Do not mix print media in the front tray; for example, do not load a stack that includes both envelopes and standard paper. Load only one type of print media.
- Do not mix print media sizes in the front tray; for example, do not load a stack that includes two or more different sizes of paper.
- Do not load print media that is obviously damaged, wet, creased, or wrinkled.
- Do not overfill the front tray.

Use the following procedure to load paper in the front tray:

1. Open the front tray by pulling the hand grip on the top of the front tray cover.

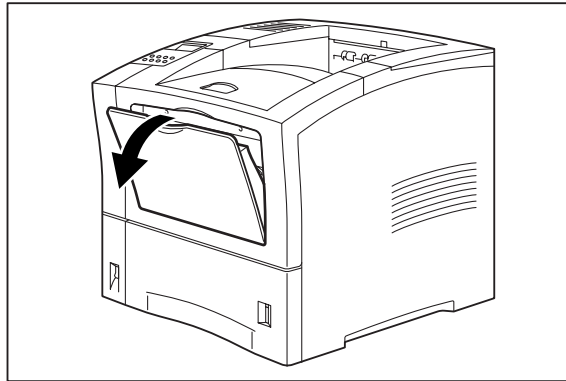

2. If you are using paper that is letter size or larger, pull out the input tray extension.

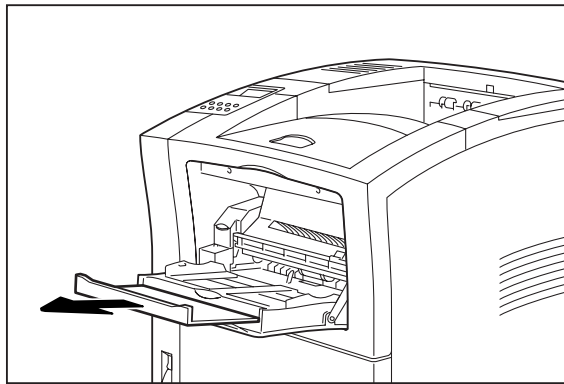

3. Slide the paper guides so they match the size of the paper that you are loading.

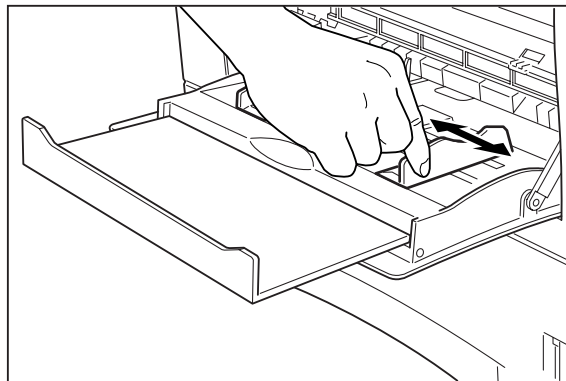

4. Stack the paper that you will load in the front tray, making sure that the edges are aligned and neat. Position the paper stack so the surface to be printed faces up.
- Load the stack of paper into the front tray by sliding the stack between the paper guides and then pushing the paper stack into the tray until it will not go any further.

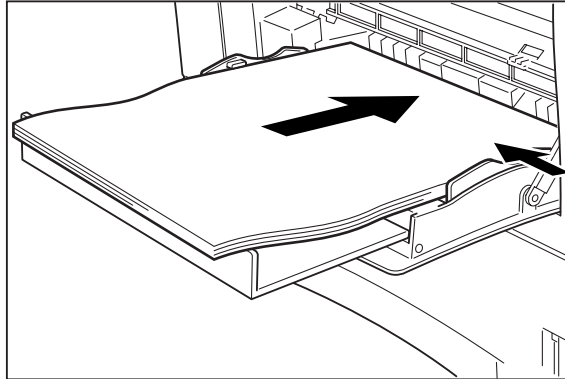

6. Check the paper stack to make sure it is not loaded at an angle and that the guides barely touch the stack.



**CAUTION:** Do not press the guides tightly against the stack; the guides should just barely touch the stack of paper. Paper guides that are too tight can cause feed jams.

---





# Chapter 3

## Understanding and Navigating the Control Panel Menus

### In this Chapter . . .

- “About this Chapter” on page 3-2
- “Control Panel Features” on page 3-2
- “Navigating the Control Panel Menus” on page 3-4
- “Menu Structure” on page 3-6
- “Paper Menu” on page 3-7
- “Interface Menu” on page 3-9
- “PS Menu” on page 3-10
- “PCL Menu” on page 3-11
- “System Menu” on page 3-13
- “Quality Menu” on page 3-15
- “Functions Menu” on page 3-16
- “Status Menu” on page 3-17

## About this Chapter

This chapter explains the control panel and its functions, and also demonstrates how to navigate throughout the various menus and submenus that allow you to view and change the printer settings.

## Control Panel Features

The control panel is located on the front of the printer, and contains the display, indicators, and pushbuttons that allow you to view and change the printer settings.

The figure below shows the control panel features.

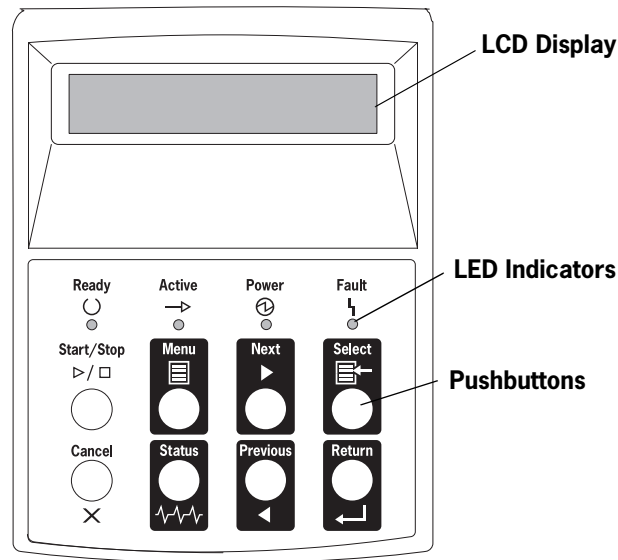





Figure 3-1: Control Panel.

## LCD Display

The LCD display shows status and error messages that inform you of the current status of the printer, and also displays menus, submenus, and printer settings when you are in the menu system. The display contains two lines of text, each with a maximum of sixteen characters.







### LED Indicators



The LED indicators also indicate printer status. The four indicators can each be on, off, or blinking, indicating different phases of printer operation. The table below explains the LED indicators.

LED	Color	When Off	When On	When Blinking
Ready 	Green	Printer is NOT READY	Printer is READY	N/A
Active 	Green	Printer is IDLE	Printer is ACTIVE (processing a job)	Printer is WAITING (a partial job has been printed, and the printer is waiting for additional job data)
Power 	Green	POWER is off	POWER is on	Power Saver Mode ON
Fault 	Yellow	Printer is not in error mode	There is an error that requires user intervention, such as a paper jam, a service call required, etc.	N/A

### Pushbuttons

The control panel pushbuttons allow you to access and navigate menus, and also assist you in recovering from printer errors. The table below explains the functions of the eight pushbuttons.

Pushbutton	Function
Start/Stop  	START/STOP—Push this button to start or stop the printer, or to exit the menu system.
	MENU—Push this button to enter the menu system.
	NEXT—Push this button to move to the next menu, submenu, or setting within the same level of the menu structure.
	SELECT—Push this button to select the menu or submenu that is shown on the second line of the display or to choose and save the setting shown on the second line of the display.
Cancel 	CANCEL—Push this button to cancel an action.

Pushbutton	Function
	STATUS—Push this button to enter the Status Menu and view the current status of printer.
	PREVIOUS—Push this button to return to the previous menu, submenu, or option within the same level of the menu structure.
	RETURN—Push this button to move up one level in the menu structure to the menu shown on the first line of the display.

### Navigating the Control Panel Menus

When you press the **MENU** button on the control panel, you enter the printer’s menu system. At that point, the first line of the display contains the text “**Menu**”, indicating that you are in the menu system. The second line of the display lists the active menu, which you can change by pressing the **NEXT** or **PREVIOUS** button.

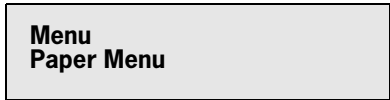

If you press the **NEXT** button repeatedly, the second line of the display cycles through the main menus in the following order:

- Paper Menu
- Interface Menu
- PS Menu
- PCL Menu
- System Menu
- Quality Menu
- Functions

---

**NOTE:** Additional menus and submenus may appear in the printer menu system when other options are installed.

---



The following figure shows the sequence of pushbuttons and display messages that would allow you to change the number of copies printed. This example illustrates the basic relationship between menus and submenus and demonstrates how the NEXT, PREVIOUS, SELECT, and RETURN buttons help you to navigate through the menus.

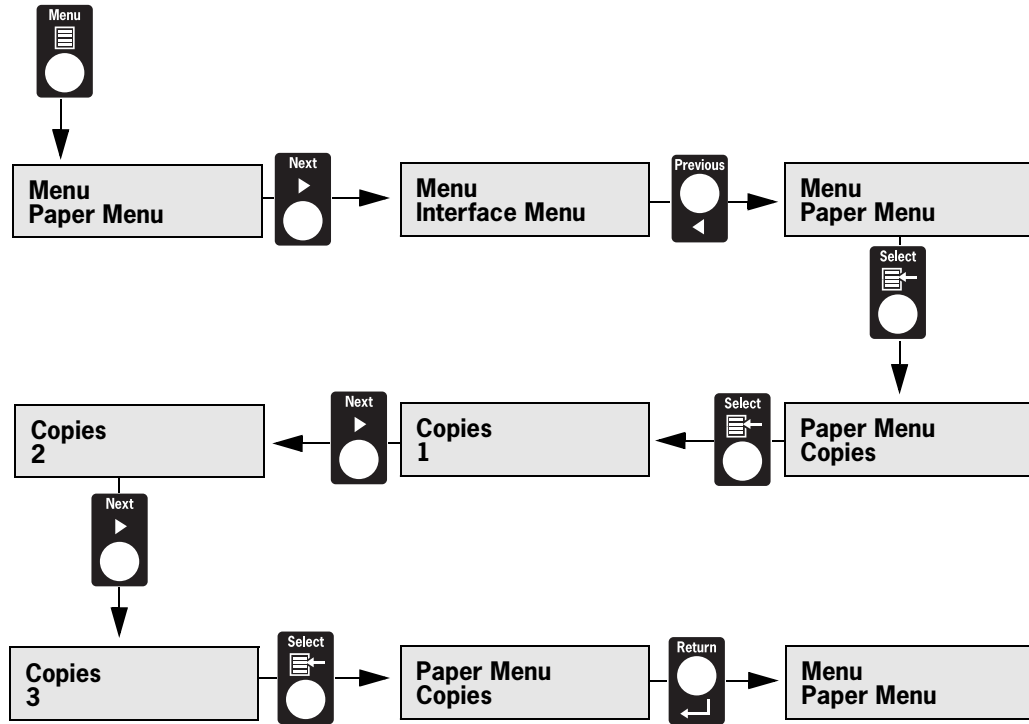
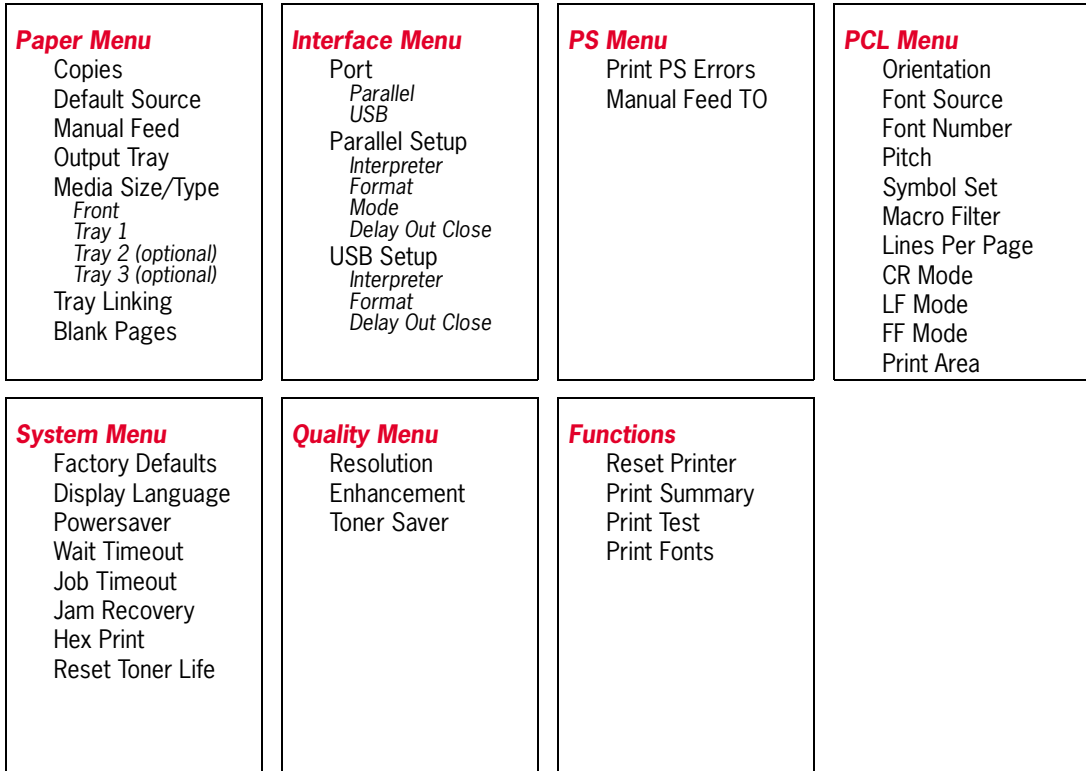

Figure 3-2: Navigating the Paper Menu.

1. Press the **MENU** button on the control panel.
2. Press the **NEXT** button until the text “**Paper Menu**” is shown on the second line of the display.
3. Press the **SELECT** button to enter the paper menu.
4. Press the **NEXT** button until the text “**Copies**” is shown on the second line of the display.
  - Press the **SELECT** button to enter the copies submenu.
6. Press the **NEXT** or **PREVIOUS** button to increase or decrease the number of copies printed.
7. Press the **SELECT** button to save this setting.
8. Press the **START/STOP** button to exit the menu system.

## Menu Structure

The following figure shows the structure of the control panel main menus and submenus. For more specific information about using and navigating the printer menu system, see the User Guide provided on the Electronic Library CD-ROM.



**Figure 3-3: Printer Menu Structure.**

---

**NOTE:** Additional menus and submenus may appear in the printer menu system when other options are installed.

---

## Paper Menu

The **Paper Menu** provides access to the printer settings for various paper-handling functions. Use the following procedure to enter the paper menu:

1. Press the **MENU** button on the control panel.
2. Press the **NEXT** button until the text "**Paper Menu**" is shown on the second line of the display.
3. Press the **SELECT** button to enter the Paper Menu.
4. Press the **NEXT** button to move through the submenus: **Copies**, **Default Source**, **Manual Feed**, **Output Tray**, **Media Size/Type**, **Tray Linking**, **Blank Pages**, and **Output Linking**.
  - Use the procedures in the following table to access and change the printer paper-handling settings:

Submenus	Default Setting	Available Settings	Procedure for Changing Setting
<b>Copies</b> This submenu allows you to change the number of copies printed.	1	Numbers 1 - 999	1. Press NEXT or PREVIOUS to increase or decrease the number of copies printed. 2. Press SELECT to save this setting.
<b>Duplex</b> This submenu allows you to turn the duplexer on or off.	Off	Off On	1. Press NEXT or PREVIOUS to toggle between ON and OFF. 2. Press SELECT to save this setting.
<b>Duplex Bind</b> This submenu allows you to define the binding edge for duplexed sheets.	Long Edge	Long Edge Short Edge	1. Press NEXT or PREVIOUS to toggle between LONG EDGE and SHORT EDGE. 2. Press SELECT to save this setting.
<b>Default Source</b> This submenu allows you to choose a default paper source from a list of all installed sources.	Tray 1	Front Tray 1 Tray 2 (optional) Tray 3 (optional)	1. Press NEXT or PREVIOUS to scroll through the list of available sources of paper. 2. Press SELECT to set a source as the default.
<b>Manual Feed</b> This submenu allows you to turn the manual feed on or off.	Off	On Off	1. Press NEXT or PREVIOUS to toggle between ON and OFF. 2. Press SELECT to save this setting.
<b>Output Tray</b> This submenu allows you to choose a default output tray from a list of all installed output trays.	Face Down Tray	Face Down Tray Offset Tray (optional)	1. Press NEXT or PREVIOUS to scroll through the list of available output trays. 2. Press SELECT to set a tray as the default.

<p><b>Media Size/Type</b>          This submenu allows you to set the media size and type for the Front Tray and set the medial type for all other trays.</p>	<p><b>Front Tray</b>          Size: Letter LEF          Type: Plain  <b>Tray 1</b>          Type: Plain  <b>Tray 2</b> (optional)          Type: Plain  <b>Tray 3</b> (optional)          Type: Plain</p>	<p><b>Size</b>          Front Tray:          Letter, A4, B5, A5, Statement, Executive, C5          Envelope, DL Envelope, Com10 Envelope, Monarch Envelope, Legal, Folio, A6</p>	<p><b>Type</b>          Front Tray:          Plain, Transparency, Prepunched, Letterhead, Colored, Preprinted, Bond, Label, Card Stock, Postcard, Envelope, Other           Other Trays:          Plain, Transparency, Prepunched, Letterhead, Colored, Preprinted, Bond, Other</p>	<ol style="list-style-type: none"> <li>1. Press NEXT or PREVIOUS to scroll through the list of available sources of paper.</li> <li>2. Press SELECT to choose a tray.</li> <li>3. Press NEXT or PREVIOUS to toggle between MEDIA SIZE and MEDIA TYPE.</li> <li>4. Press SELECT to choose either.</li> <li>5. Press NEXT or PREVIOUS to scroll through the available sizes or types.</li> <li>6. Press SELECT to set a size or type.</li> </ol>
<p><b>Tray Linking</b>          This submenu allows you to turn the tray linking function on or off.</p>	<p>On</p>	<p>On Off</p>	<ol style="list-style-type: none"> <li>1. Press NEXT or PREVIOUS to toggle between ON and OFF.</li> <li>2. Press SELECT to save this setting.</li> </ol>	
<p><b>Blank Pages</b>          This submenu allows you to choose to either print or not print blank pages of a document.</p>	<p>Print</p>	<p>Print Do Not Print</p>	<ol style="list-style-type: none"> <li>1. Press NEXT or PREVIOUS to toggle between PRINT and DO NOT PRINT.</li> <li>2. Press SELECT to save this setting.</li> </ol>	
<p><b>Output Linking</b>          This submenu allows you to turn the output linking function on or off.</p>	<p>Off</p>	<p>On Off</p>	<ol style="list-style-type: none"> <li>1. Press NEXT or PREVIOUS to toggle between ON and OFF.</li> <li>2. Press SELECT to save this setting.</li> </ol>	

## Interface Menu

The **Interface Menu** provides access to the printer interface settings. Use the following procedure to enter the interface menu:

1. Press the **MENU** button on the control panel.
  2. Press the **NEXT** button until the text “**Interface Menu**” is shown on the second line of the display.
  3. Press the **SELECT** button to enter the interface menu.
  4. Press the **NEXT** button to move through the submenus: **Port, Parallel Setup, and USB Setup**.
- . Use the procedures in the following table to access and change the printer interface settings:

Submenus	Default Setting	Available Settings	Procedure for Changing Setting
<p><b>Port</b> This submenu allows you to choose the type of interface. The parallel and USB ports can not be ON simultaneously.</p>	<p><b>Parallel:</b> On</p> <p><b>USB:</b> Off</p>	<p><b>Parallel :</b> On, Off</p> <p><b>USB:</b> On, Off</p>	<ol style="list-style-type: none"> <li>1. Press NEXT or PREVIOUS to toggle between PARALLEL and USB.</li> <li>2. Press SELECT to save this setting.</li> </ol>
<p><b>Parallel Setup</b> This submenu allows you to set up the parallel interface. When the Parallel port is on, the USB port is off.</p>	<p><b>Interpreter:</b> Auto Switch</p> <p><b>Format:</b> Raw</p> <p><b>Mode:</b> Bidirectional</p> <p><b>Delay Out Close:</b> Off</p>	<p><b>Interpreter:</b> Auto Switch PCL PostScript 3</p> <p><b>Format:</b> Raw Normal Binary</p> <p><b>Mode:</b> Bidirectional Standard</p> <p><b>Delay Out Close:</b> On Off</p>	<ol style="list-style-type: none"> <li>1. Press NEXT or PREVIOUS to scroll through the INTERPRETER, FORMAT, and MODE submenus.</li> <li>2. Press SELECT to choose a submenu.</li> <li>3. Press NEXT or PREVIOUS to scroll through the settings.</li> <li>4. Press SELECT to choose and save a setting.</li> </ol>
<p><b>USB Setup</b> This submenu allows you to choose set up the USB interface. When the USB port is on, the parallel port is off.</p>	<p><b>Interpreter:</b> Auto Switch</p> <p><b>Format:</b> Raw</p>	<p><b>Interpreter:</b> Auto Switch PCL PostScript 3</p> <p><b>Format:</b> Raw Normal Binary</p>	<ol style="list-style-type: none"> <li>1. Press NEXT or PREVIOUS to toggle between INTERPRETER and FORMAT submenus.</li> <li>2. Press SELECT to choose either submenu.</li> <li>3. Press NEXT or PREVIOUS to scroll through the settings.</li> <li>4. Press SELECT to save this setting.</li> </ol>

## PS Menu

The PS Menu provides access to the PostScript settings. Use the following procedure to enter the PS Menu:

1. Press the **MENU** button on the control panel.
2. Press the **NEXT** button until the text “**PS Menu**” is shown on the second line of the display.
3. Press the **SELECT** button to enter the PS menu.
4. Press the **NEXT** button to move through the submenus: **Print PS Errors**, and **Manual Feed TO**.
  - . Press the **SELECT** button to enter a submenu.
6. Use the procedures in the following table to access and change the PostScript settings:

Submenus	Default Setting	Available Settings	Procedure for Changing Settings
<b>Print PS Errors</b> This submenu allows you to choose to either print or not print PS errors.	Off	On Off	1. Press <b>NEXT</b> or <b>PREVIOUS</b> to toggle between <b>ON</b> (print) and <b>OFF</b> (do not print). 2. Press <b>SELECT</b> to save this setting.
<b>Manual Feed TO</b> This submenu allows you to set the manual feed timeout—the number of seconds the printer should wait for a manual feed. A setting of 0 will cause printer to wait indefinitely for a manual feed.	0	0 - 99999	1. Press <b>NEXT</b> or <b>PREVIOUS</b> to increase or decrease each digit of the five-digit number. 2. Press <b>SELECT</b> to move to the next number. 3. Press <b>SELECT</b> after setting the last digit to save the setting.

## PCL Menu

The **PCL Menu** provides access to the PCL settings. Use the following procedure to enter the PCL menu:

1. Press the **MENU** button on the control panel.
2. Press the **NEXT** button until the text “**PCL Menu**” is shown on the second line of the display.
3. Press the **SELECT** button to enter the PCL menu.
4. Press the **NEXT** button to move through the submenus: **Print PS Errors, Manual Feed TO**.
  - Press the **SELECT** button to enter a submenu.
6. Use the procedures in the following table to access and change the PCL settings:

Submenus	Default Setting	Available Settings	Procedure for Changing Setting
<b>Orientation</b> This submenu allows you to choose the orientation of the page.	Portrait	Portrait Landscape	<ol style="list-style-type: none"> <li>1. Press NEXT or PREVIOUS to toggle between PORTRAIT and LANDSCAPE.</li> <li>2. Press SELECT to choose and save an orientation.</li> </ol>
<b>Font Source</b> This submenu allows you to choose a font source.	Internal	Internal	<ol style="list-style-type: none"> <li>1. Press NEXT or PREVIOUS to scroll through the available font sources.</li> <li>2. Press SELECT to choose and set a source.</li> </ol>
<b>Font Number</b> This submenu allows you to set the font number.	0	Numbers 0-?	<ol style="list-style-type: none"> <li>1. Press NEXT or PREVIOUS to increase or decrease the font number.</li> <li>2. Press SELECT to save this setting.</li> </ol>
<b>Pitch</b> This submenu allows you to change the pitch of text.	10.00	0.08 - 100.00	<ol style="list-style-type: none"> <li>1. Press NEXT or PREVIOUS to increase or decrease the pitch.</li> <li>2. Press SELECT to save this setting.</li> </ol>
<b>Symbol Set</b> This submenu allows you to choose a symbol set.	10U:PC-8 CP437	10U:PC-8 CP437    15U:Pi Font 11U:PC-8 D/N     1U: Legal 12U:PC-850       1E: ISO4 UK 17U:PC-852       0U:ISO6 ASCII 9T:PC-Turkish    0U:ISO11 Swedish 19U:WIN Latin1   0I:ISO15 Italian 9E:WIN Latin2    2S:ISO17 Spanish 5T:WIN Latin5    1G:ISO21 German 7J:Desk Top       0D:ISO60 Norweg. 10J:PS Text       1F:ISO69 French 13J:Ventura Intl   9U:WIN3.0 Latin1 14J:Ventura US    8U:Roman 8 6J:Microsoft Pub  0N:ISO 8859-1 8M:Math-8        2N:ISO 8859-2 PS:Math           5N:ISO 8859-5 6M:Ventura Math	<ol style="list-style-type: none"> <li>1. Press NEXT or PREVIOUS to scroll through the available symbol sets.</li> <li>2. Press SELECT to choose and set a symbol set.</li> </ol>

<p><b>Macro Filter</b> This submenu allows you to turn the macro filter on or off.</p>	Off	On Off	<ol style="list-style-type: none"> <li>1. Press NEXT or PREVIOUS to toggle between ON and OFF.</li> <li>2. Press SELECT to save this setting.</li> </ol>
<p><b>Lines Per Page</b> This submenu allows you to change the number of lines per page.</p>	64	5 - 128	<ol style="list-style-type: none"> <li>1. Press NEXT or PREVIOUS to increase or decrease the lines per page.</li> <li>2. Press SELECT to save this setting.</li> </ol>
<p><b>CR Mode</b> This submenu allows you to define the action prompted by a carriage return—a carriage return equals either a carriage return alone, or a carriage return and a line feed together.</p>	CR = CR	CR = CR CR = CR/LF	<ol style="list-style-type: none"> <li>1. Press NEXT or PREVIOUS to choose from CR=CR or CR=CR/LF.</li> <li>2. Press SELECT to save this setting.</li> </ol>
<p><b>LF Mode</b> This submenu allows you to define the action prompted by a line feed—a line feed equals either a line feed alone or a carriage return and a line feed together.</p>	LF = LF	LF = LF LF = CR/LF	<ol style="list-style-type: none"> <li>1. Press NEXT or PREVIOUS to choose from LF=LF or LF=CR/LF.</li> <li>2. Press SELECT to save this setting.</li> </ol>
<p><b>FF Mode</b> This submenu allows you to define the action prompted by a form feed—a form feed equals either a form feed alone or a carriage return and a form feed together.</p>	FF = FF	FF = FF FF = CR/FF	<ol style="list-style-type: none"> <li>1. Press NEXT or PREVIOUS to choose from FF=FF or FF=CR/FF.</li> <li>2. Press SELECT to save this setting.</li> </ol>
<p><b>Print Area</b> This submenu allows you to expand the print area.</p>	Normal	Normal Expanded	<ol style="list-style-type: none"> <li>1. Press NEXT or PREVIOUS to toggle between Normal and Expanded.</li> <li>2. Press SELECT to save this setting.</li> </ol>



## System Menu

The system menu provides access to system settings. Use the following procedure to enter the system menu:

1. Press the **MENU** button on the control panel.
2. Press the **NEXT** button until the text “**System Menu**” is shown on the second line of the display.
3. Press the **SELECT** button to enter the system menu.
4. Press the **NEXT** button to move through the submenus: **Factory Defaults**, **Display Language**, **Power Saver**, **Wait Timeout**, **Job Timeout**, **Jam Recovery**, and **Hex Print**.
  - Press the **SELECT** button to enter a submenu.
6. Use the procedures in the following table to access and change the system settings:

Submenus	Default Setting	Available Settings	Procedure for Changing Setting
<b>Factory Defaults</b> This submenu allows you to reset the printer to U.S. or Non-U.S. factory defaults.	U.S.	U.S. Non-U.S.	1. Press NEXT or PREVIOUS to toggles between U.S. and NON-U.S. 2. Press SELECT to choose and set the factory defaults.
<b>Display Language</b> This submenu allows you to change the language of the display messages.	English	English French German Italian Spanish	1. Press NEXT or PREVIOUS to scroll through the available languages: English, French (Francais), German (Deutsch), Italian (Italiano), or Spanish (Espanol). 2. Press SELECT to choose and set the language.
<b>Power Saver</b> This submenu allows you to set the number of minutes the printer is idle before it reverts to Power Saver Mode.	15	0 - 999	1. Press NEXT or PREVIOUS to increase or decrease the number of minutes. 2. Press SELECT to save this setting.
<b>Wait Timeout</b> This submenu allows you to increase or decrease the length of time (in seconds) that the printer will remain in the waiting state—a job is being processed, no end-of-file has been detected, and there is no more data to process. This setting applies to <i>both PCL and PostScript print jobs</i> .	20	0 - 99999	1. Press NEXT or PREVIOUS to increase or decrease each digit of the five-digit number. 2. Press SELECT set one digit and move to the next digit. 3. Press SELECT after changing the last digit to save this setting.
<b>Job Timeout</b> This submenu allows you to increase or decrease the time limit (in seconds) for PostScript jobs. A 0 setting indicates no timeout. This setting applies <i>only to PostScript jobs</i> .	0	0 - 99999	1. Press NEXT or PREVIOUS to increase or decrease each digit of the five-digit number. 2. Press SELECT set one digit and move to the next digit. 3. Press SELECT after changing the last digit to save this setting.

<p><b>Jam Recovery</b>          This submenu allows you to turn jam recovery on or off.</p>	<p>On</p>	<p>On Off</p>	<p>1. Press NEXT or PREVIOUS to toggle between ON and OFF.          2. Press SELECT to save this setting.</p>
<p><b>Hex Print</b>          This submenu allows you to print hexadecimal characters.</p>	<p>Off</p>	<p>On Off</p>	<p>1. Press NEXT or PREVIOUS to toggle between ON and OFF.          2. Press SELECT to save this setting.</p>
<p><b>Reset Toner Life</b></p>	<p>Press SELECT to reset the toner page count.</p>		

## Quality Menu

The Quality Menu provides access to the printer settings that are related to print quality. Use the following procedure to enter the Quality Menu:

1. Press the **MENU** button on the control panel.
2. Press the **NEXT** button until the text “**Quality Menu**” is shown on the second line of the display.
3. Press the **SELECT** button to enter the system menu.
4. Press the **NEXT** button to move through the submenus: **Resolution, Enhancement, and Toner Saver**.
  - . Press the **SELECT** button to enter a submenu.
6. Use the procedures in the following table to access and change the system settings:

Submenus	Default Setting	Available Settings	Procedure for Changing Setting
----------	-----------------	--------------------	--------------------------------

## Functions Menu

The Functions Menu provides access to several printer functions that can supply you with information about the printer and its settings. Use the following procedure to enter the Functions Menu:

1. Press the **MENU** button on the control panel.
  2. Press the **NEXT** button until the text “**Functions Menu**” is shown on the second line of the display.
  3. Press the **SELECT** button to enter the system menu.
  4. Press the **NEXT** button to move through the available functions: **Reset Printer, Print Summary, Print test, and Print Fonts.**
- . Use the procedures in the following table to execute the functions:

<b>Functions</b>	<b>Procedure for Executing Function</b>
<b>Reset Printer</b> This function resets the printer.	Press <b>SELECT</b> to reset the printer.
<b>Print Summary</b> This function prints a list of all printer settings:	Press <b>SELECT</b> to print a summary of the printer settings.
<b>Print Test</b> This function allows you to print a single test page or a continuous test page.	1. Press <b>NEXT</b> or <b>PREVIOUS</b> to toggle between <b>SINGLE PAGE</b> and <b>CONTINUOUS</b> . 2. Press <b>SELECT</b> to print the test page(s).
<b>Print Fonts</b> This function allows you to print Postscript or PCL font lists.	1. Press <b>NEXT</b> or <b>PREVIOUS</b> to toggle between <b>POSTSCRIPT</b> and <b>PCL</b> . 2. Press <b>SELECT</b> to select and print the specific fonts list.

## Status Menu

In addition to the main menus listed above, the printer also provides a status menu that allows you to view the current settings for the input and output trays and the toner cartridge. Use the following procedure to enter the Status Menu:

1. Press the **STATUS** button on the control panel.
2. Press the **NEXT** button to move through the submenus: **Front, Tray 1, Tray 2, Tray 3, Face Down, and Toner.**
3. Press the **SELECT** button to enter a submenu.
4. Use the procedures in the following table to view the status of the printer:

Submenu	Procedure for Executing Function
<b>Front</b> This submenu allows you to view the current Media Size and Media Type for the front tray.	1. Press NEXT or PREVIOUS to scroll through the media size, media type, and level settings for the Front Tray. 2. Press SELECT to view a specific setting.
<b>Tray 1</b> This submenu allows you to view the current Media Size, Media Type, and Level for Tray 1.	1. Press NEXT or PREVIOUS to scroll through the media size, media type, and level settings for Tray 1. 2. Press SELECT to view a specific setting.
<b>Tray 2</b> This submenu allows you to view the current Media Size, Media Type, and Level for Tray 2.	1. Press NEXT or PREVIOUS to scroll through the media size, media type, and level settings for Tray 2. 2. Press SELECT to view a specific setting.
<b>Tray 3</b> This submenu allows you to view the current Media Size, Media Type, and Level for Tray 3.	1. Press NEXT or PREVIOUS to scroll through the media size, media type, and level settings for Tray 3. 2. Press SELECT to view a specific setting.
<b>Face Down Tray</b> This submenu allows you to view the status of the face down tray.	1. Press SELECT to view the status of the Face Down Tray.
<b>Toner</b> Press SELECT to view the status of the toner cartridge.	





# Chapter 4

## Maintaining the Printer

### In this Chapter . . .

- “About this Chapter” on page 4-2
- “Upgrading Printer Firmware” on page 4-2
- “Replacing Printer Components” on page 4-3
- “Cleaning the Printer” on page 4-17
- “Moving the Printer” on page 4-21
- “Storing the Printer for Long Periods of Time” on page 4-22

## About this Chapter

This chapter provides information about maintaining your printer. Although the printer requires very little maintenance, with normal daily use you will need to perform some routine maintenance procedures, including replacing consumable items and cleaning the printer. This chapter also contains information about moving and storing the printer.

## Upgrading Printer Firmware

The executable firmware for the printer controller is stored in FLASH memory. You can easily upgrade this firmware on site when a new version of code is available. The upgrade process involves sending the new code, which is usually named with a .LOD extension, to the printer using either the parallel or network interface. When the printer receives the file, it will automatically recognize it as a firmware upgrade file and will program it into the FLASH memory. During this process the printer will display information about each sub-file that it is receiving or programming. When finished, the printer displays the text “Upgrade Completed” and reboots, executing the new firmware.

Contact your dealer or service provider for more information about firmware upgrades.

### Upgrading Firmware Using the Parallel Interface

To upgrade the printer using the parallel interface, go to the DOS prompt and use the copy command to copy the new file to the printer. For example, type “copy newversion.lod/b lpt1” at the DOS prompt, where “newversion” is the name of the firmware upgrade file and “lpt1” is the printer you would like to upgrade. Be sure to use the “/b” switch on the copy command line to ensure that the data is sent in binary mode.

---

**NOTE:** If you are using a PC that is not running Windows or if you do not have any printer drivers installed and configured to use the parallel interface, you will need to configure the parallel port for permanent retry by entering the following command PRIOR to entering the copy command discussed above: mode lpt1:,,p

If you are running Windows, you may get an error message during the upgrade process that indicates that the printer is busy or that there is a printer error. This message box will contain check-boxes for “Retry” or “Cancel”. DO NOT SELECT CANCEL. This error message is only a result of the printer programming a large file into FLASH memory and will disappear once the programming is completed.

---

### Upgrading Firmware Using the Network Interface

To upgrade printer firmware using the network interface, simply send the new file to the printer using whatever procedure you normally use to send a print file. This procedure varies depending on the network environment.



## Replacing Printer Components

### Replacing the Toner Cartridge

The toner cartridge contains the dry ink as well as the xerographic drum and associated components that create the xerographic image on a sheet of paper. The toner cartridge will eventually run out of ink through normal use. When the toner is low, printed images will be uneven or very light. Use the following guidelines when using or storing a toner cartridge:

- An unopened and correctly stored toner cartridge has a shelf life of approximately two years.
- Do not open the box containing the toner cartridge until you are ready to install the cartridge into the printer.
- Store the toner cartridge box horizontally—not on end.
- Keep the cartridge out of the reach of children, and in an area where the temperature remains between 32°F and 95°F and the humidity remains between 15% to 85%. If you bring a cold toner cartridge into a warm room, wait a least an hour for the temperature to stabilize before opening the cartridge box.
- Do not disassemble the toner cartridge.
- Toner is a safe material, but if you get any on your hands **DO NOT** wash them in hot water. Use only cold water to wash off toner. Hot water sets the toner and makes it difficult to remove.
- A shutter protects the photosensitive drum from ambient light. Do not open the drum shutter by hand.

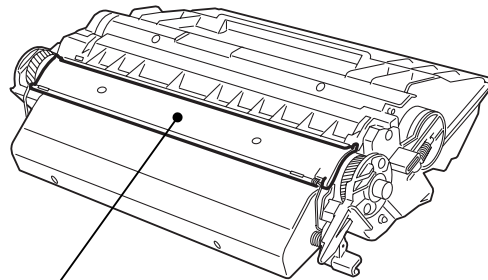

**Drum Shutter**



**CAUTION:** Do not expose the new toner cartridge to strong light for more than a few minutes before installing it into the printer.



**WARNING!** Do not dispose of used toner cartridges in an incinerator or in an open fire.

Use the following procedure to replace the toner cartridge:

1. Place a drop-cloth or some paper on the table or floor near the printer.
2. Press the button on the top of the printer to open the front cover, and pull the cover all the way open.

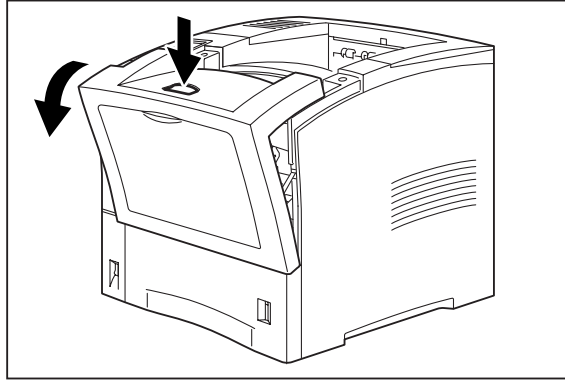

3. Remove the old toner cartridge from the printer and carefully place it on the drop-cloth.

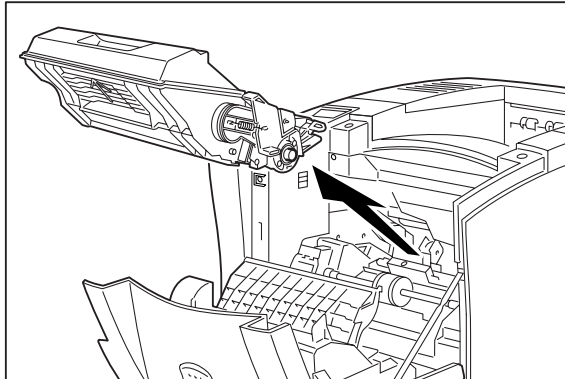

4. Remove the new toner cartridge from its packaging.
  - Rock the toner cartridge back and forth and then shake it horizontally to ensure that the toner is evenly distributed.

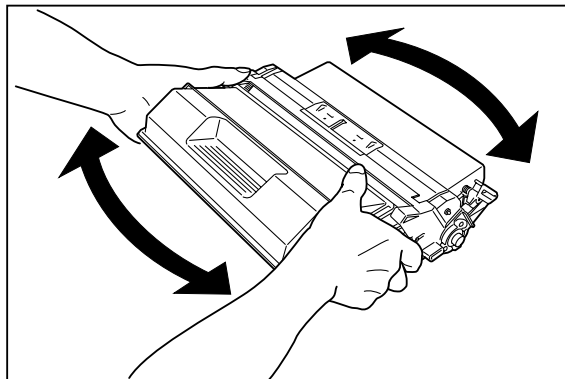

6. Grasp the toner cartridge firmly and pull the sealing tape straight out from the cartridge.

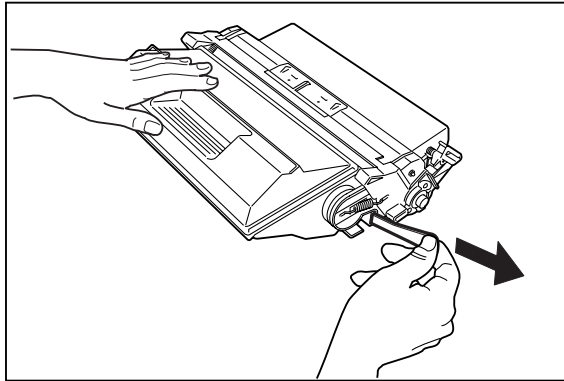

7. Slide the pegs on the toner cartridge into the channels on the inside of the printer, and lower the toner cartridge into the printer.

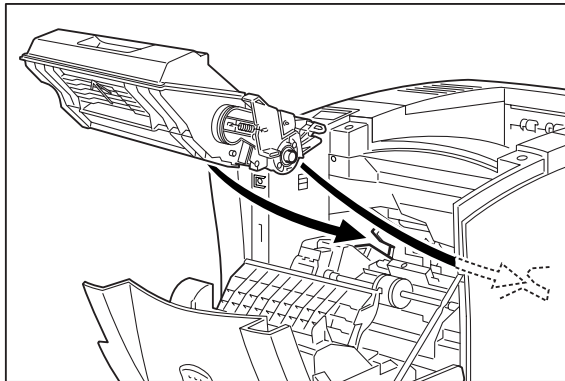

8. Close the front cover.

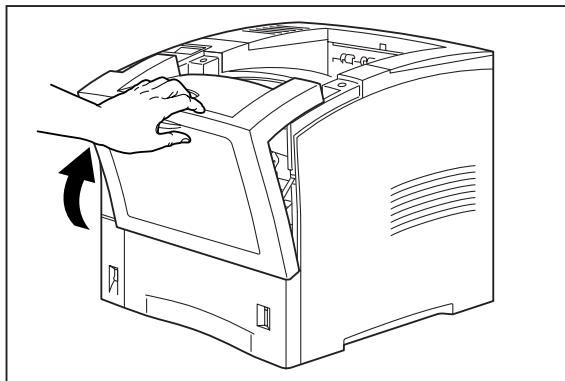

### Disposing of the Print Cartridge

1. Place the used toner cartridge inside the new toner cartridge box and seal the box.

2. Dispose of or recycle the used toner cartridge.



**WARNING!** Do not dispose of the old toner cartridge in an incinerator or in an open fire.

### Replacing the Fuser

The fuser melts the toner image into the paper to form a finished print. The fuser wears with normal use and can leave dirt or marks on printed sheets when worn. The normal life of a fuser is approximately 200,000 A4/Letter size prints at 5% area coverage. Running high image density prints or large format paper will cause the fuser life to be shorter.



**WARNING!** The fuser becomes very hot during operation. Do not touch the fuser until it is cool.

**NOTE:** In the following procedure, the left and right sides of the printer are those to the left and right of a person facing the rear of the printer.

**NOTE:** If you are using the duplexer, refer to "Chapter 6 Using the Duplexer" and remove the duplexer before attempting to replace the fuser.

Use the following procedure to remove and replace the fuser:

1. Turn the printer off by pressing the [ O ] on the power switch on the front of the printer, and disconnect the AC power cord from the wall outlet. Wait at least 30 minutes before proceeding to remove the fuser.

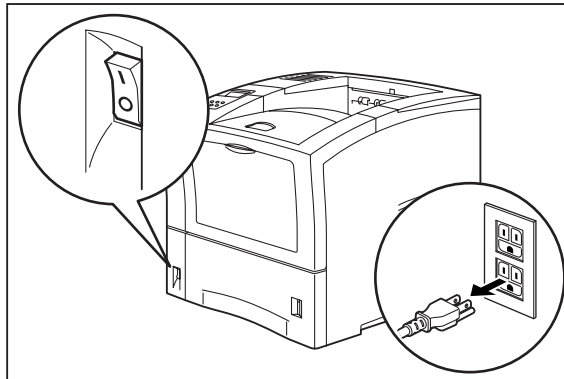

2. Squeeze the tabs on the top of the rear cover, and pull the cover toward you to open it.

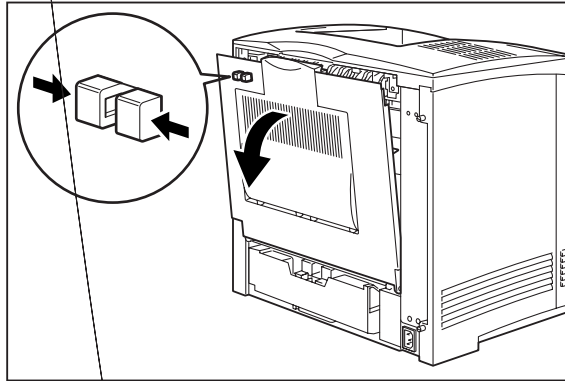

3. Remove the screws that secure the fuser to the printer.

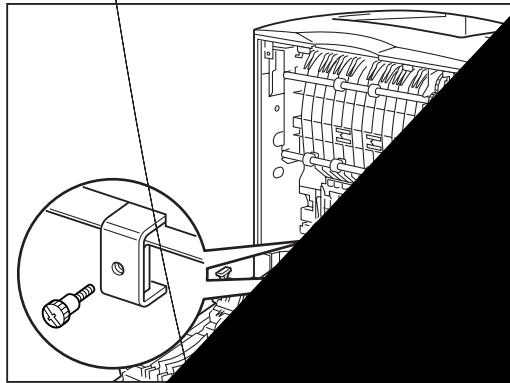

4. Grasp the metal brackets on the fuser assembly and pull them away from the printer.

6. Insert the new fuser into the printer, making sure it is securely seated.

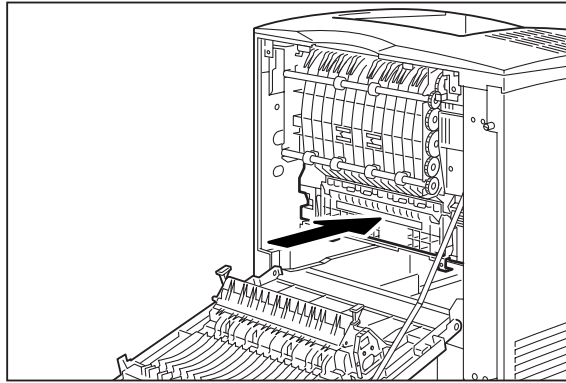

7. Secure the fuser to the printer by replacing and tightening the screws.

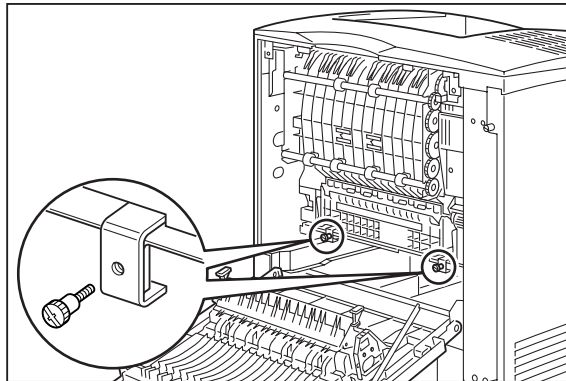

8. Close the rear cover.

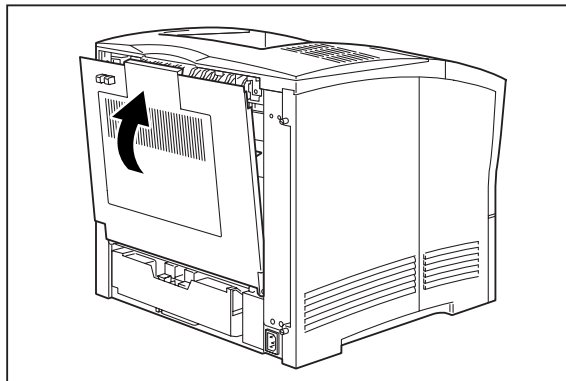

9. Verify that the power switch of the printer is in the [O] (off) position, then insert the plug of the power cord into the AC outlet.

10. Turn the printer on by pressing [ I ] on the power switch on the front of the printer.

### Replacing Feed Roll, Nudger Roll, and Retard Roll

Rubber feed rolls drive sheets of paper out of the feeder paper trays into the printer. These feed rolls wear with normal use and eventually become coated with paper dust and must be replaced. Frequent feed jams in the front tray or main tray indicate that the feed rolls need to be replaced.

---

**NOTE:** The following procedure illustra.001dn130.12.3(u)10(1(b)4.5.08 th)-7.3(e)-275.7pdr12.3(u)-12.3fgurela.001d(c)-

1. Turn the printer off by pressing the [ O ] on the power switch on the right side of the printer, and disconnect the AC power cord from the wall outlet.

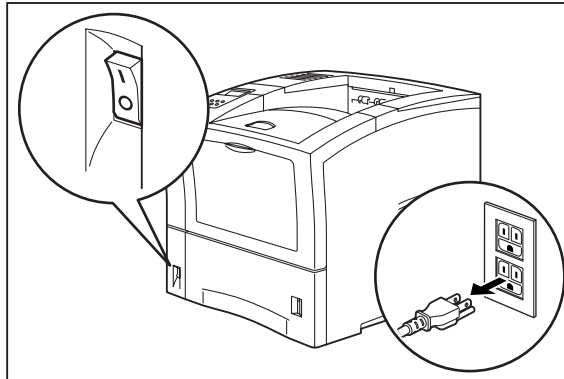

2. Remove the paper tray of the feeder that you intend to replace rolls on and set it on a flat level surface.

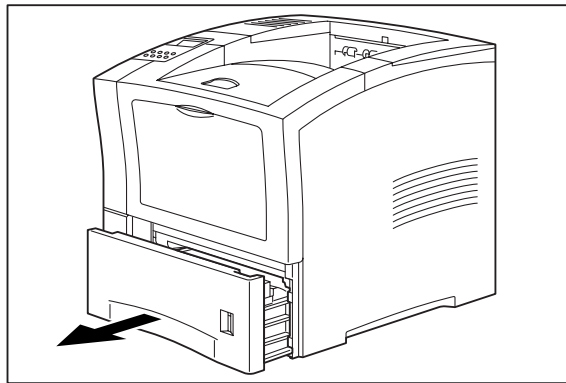

3. Pull the metal stopper plate down.

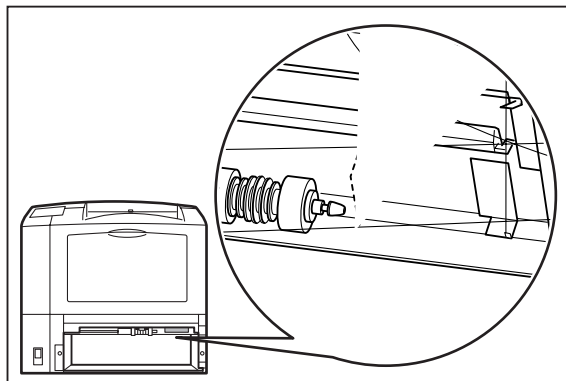



4. Unclip the retaining tabs on the end of the feed roll and nudger roll, and remove the rolls from their shafts.

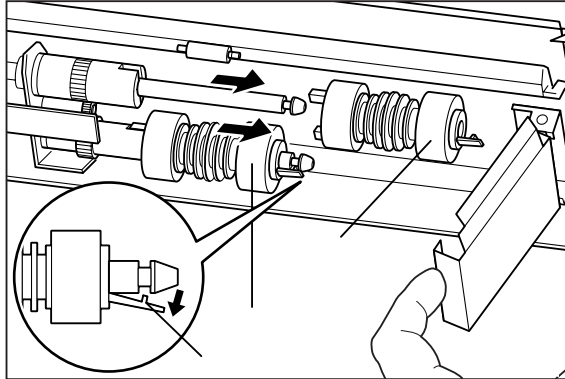

5. Push the new feed roll and nudger roll onto their shafts until the retaining tabs click into place. Make sure the tabs are toward the right side of the printer.

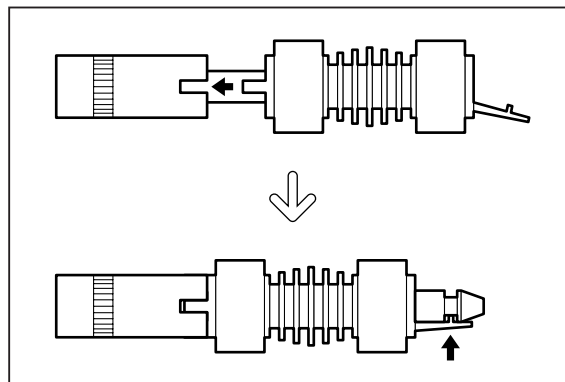
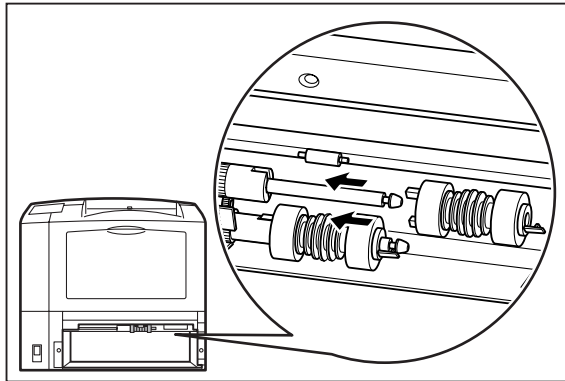

6. Release the metal stopper plate inside the printer so it returns to its normal position.

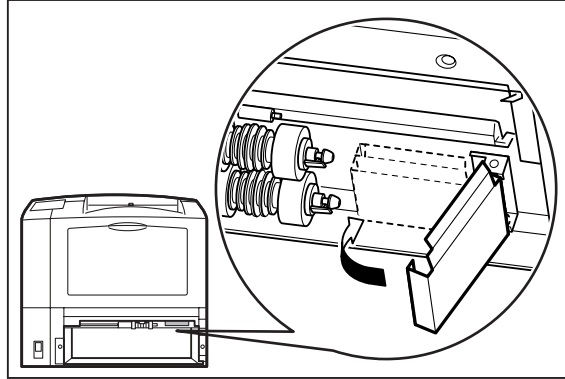

7. Press the locks on the left and right of the retard roll inside the paper tray, and lift the lever to open the retard roll cover.

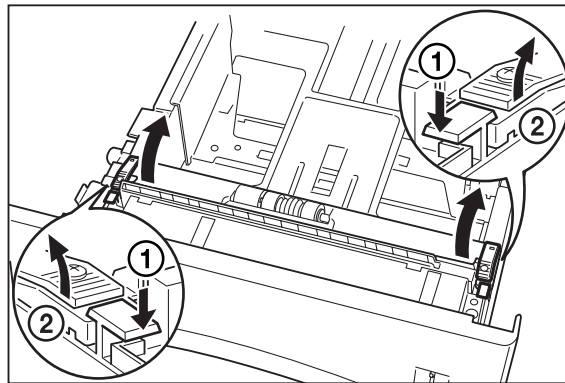

8. Unclip the retaining tab on the retard roll and remove it from the shaft.

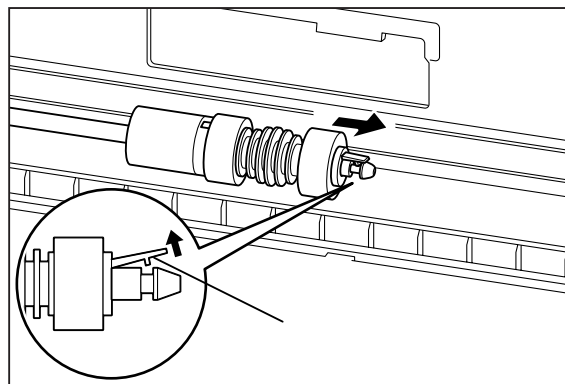

9. Push the new retard roll onto retaining tab is toward the r

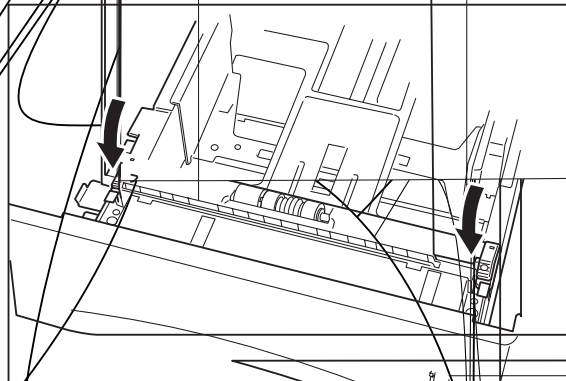

11. Grasp the paper tray with both hands and insert it into the paper tray well on the printer.

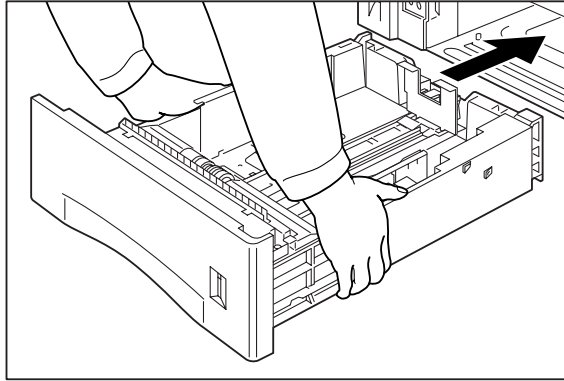

12. Push the paper tray all the way into the printer, making sure the tray is properly seated.

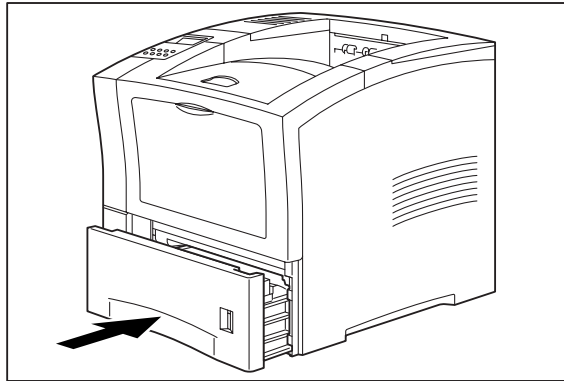

### Replacing the BTR Roller

Use the procedure below to replace the BTR roller:

1. Turn the printer off by pressing [ O ] on the power switch on the front of the printer, and disconnect the power cord from the AC wall outlet.

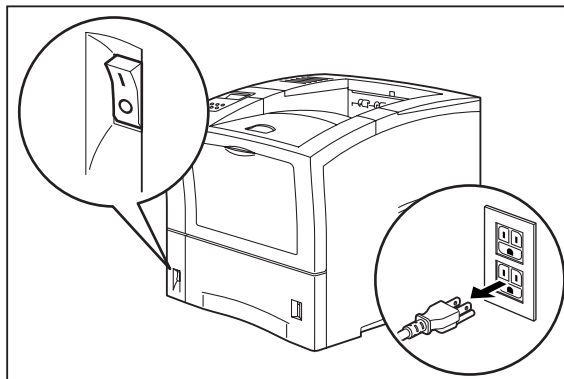

2. Push the button on top of the printer to release the front cover, and pull the front cover toward you to open it.

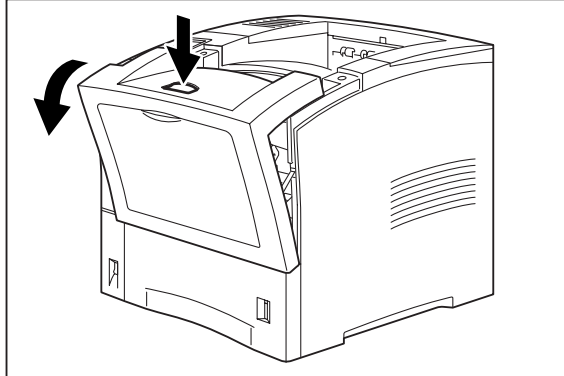

3. Remove the toner cartridge from the printer.

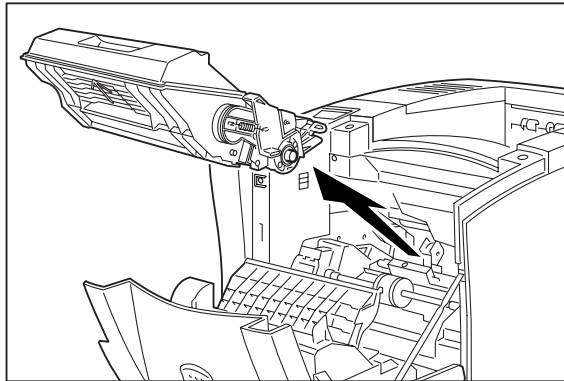

---

**NOTE:** To prevent stains, place the toner cartridge on some old newspaper or other disposable surface.

---

4. Raise the BTR roller by pressing the two levers on the left and right sides of the plate that sits behind the BTR roller.

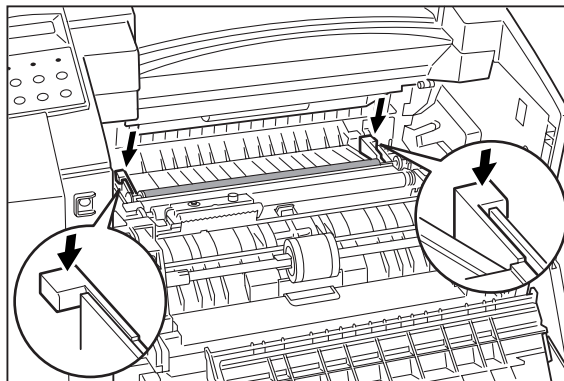

- Holding both ends of the BTR roller, pull it toward you and lift it out of the printer.

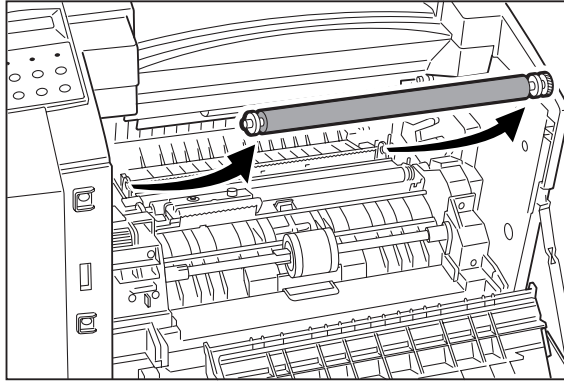

6. Position the new BTR roller so the gear is at the right end of the roller. Insert the left end of the shaft into the left clip inside the printer, then insert the right end into the right clip.

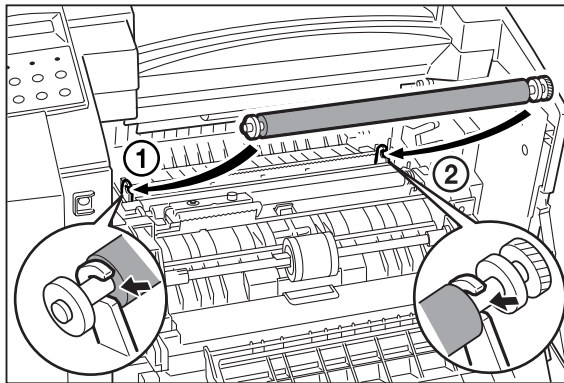

7. Press the BTR roller down until it locks firmly in place.

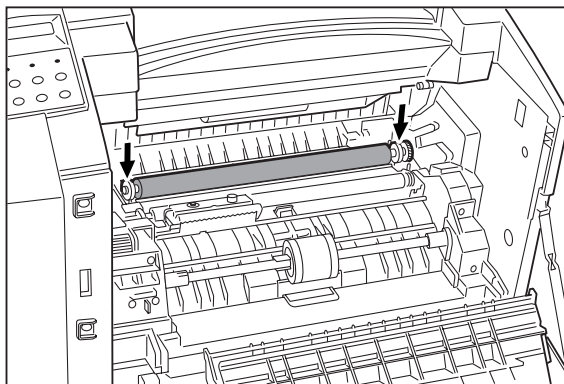

8. Insert the pegs on the toner cartridge into the channels inside the printer, and push the toner cartridge into the printer.

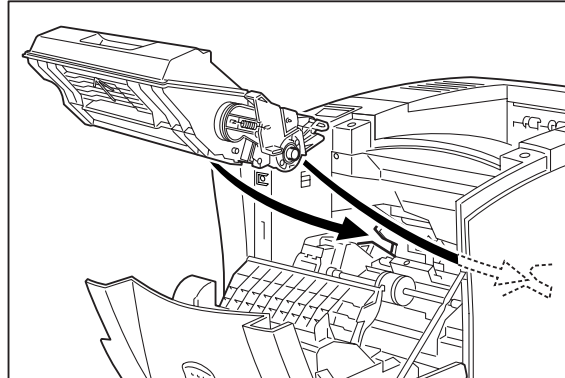

9. Close the front cover, pressing on the center of the cover until it locks firmly in place.

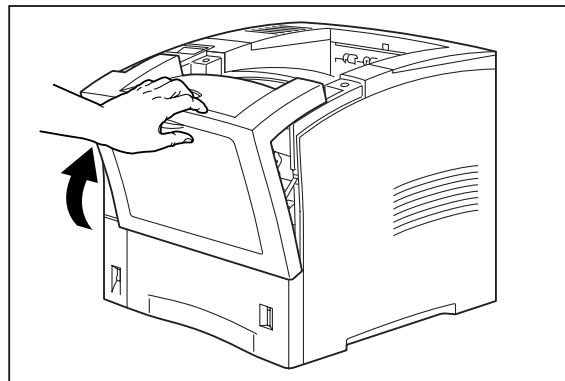

## Cleaning the Printer

### Cleaning the Exterior

The covers and tray faces of the printer may collect dust and dirt through normal use. Although exterior dirt should not affect printer performance, an occasional exterior cleaning helps maintain the appearance of the printer appearance. Use the following procedure to clean the exterior of the printer:

1. Turn the printer off by pressing the [ O ] on the power switch on the right side of the printer, and disconnect the AC power cord from the wall outlet.

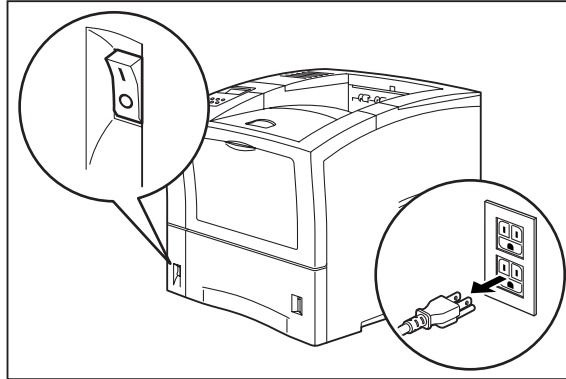

2. Using a soft cloth that is slightly damp with cold water, wipe the printer covers and tray faces. Use a very mild, non-abrasive soap to remove heavy dirt and toner stains.

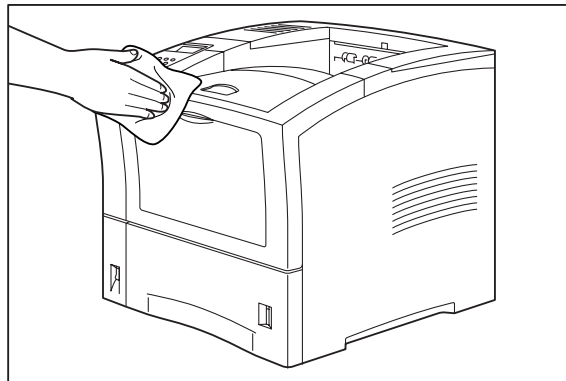

Do not use solvents or abrasive cleaners to clean printer covers. Use only cold water and a very mild soap.

---

3. Use a soft, dry cloth to thoroughly dry the covers and tray faces.



4. Verify that the power switch of the printer is in the [O] (off) position, then insert the plug of the power cord into the AC outlet.

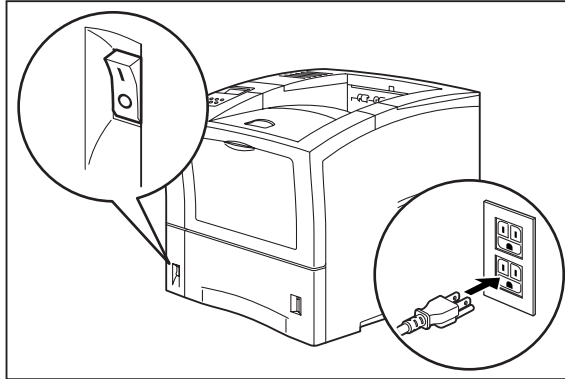

5. Turn the printer on by pressing [ I ] on the power switch on the right side of the printer.

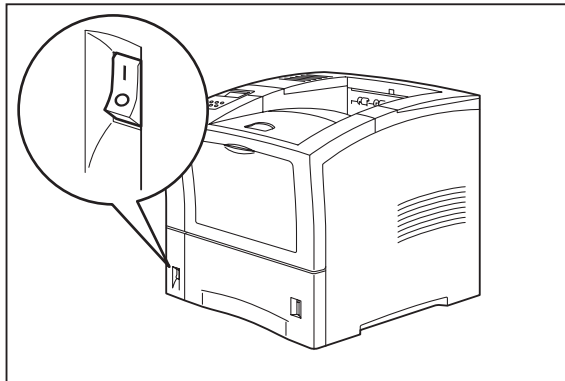

### Cleaning the Interior

The interior of the printer does not generally need to be cleaned unless a paper jam drops toner onto the paper path or you accidentally spill toner inside the printer when installing a new toner cartridge. Use the following procedure to clean the interior of the printer only when necessary:



Since there is always the possibility of damaging delicate printer components by carelessness or vigorous cleaning methods, GENICOM recommends that you clean the interior only when you are instructed to do so by a service representative or in a troubleshooting procedure presented in this manual.

1. After removing a paper jam or replacing the toner cartridge, remove any paper scraps from inside the printer and wipe off paper dust with a clean, dry cloth.

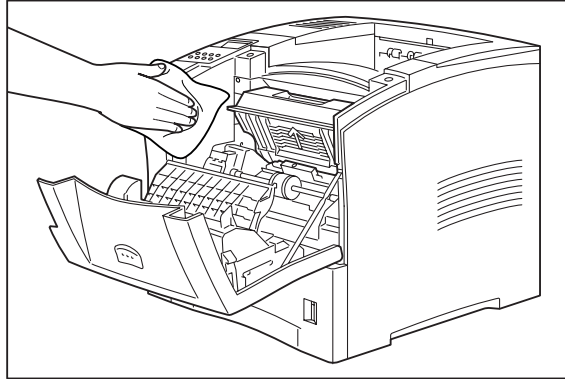

## Moving the Printer

Follow the guidelines below when lifting or moving the printer:

- The printer is very heavy, and should always be lifted by two people. The weight of the printer without paper tray, toner cartridge, and paper is about 55 lbs (25 kg). Never attempt to lift the printer alone.

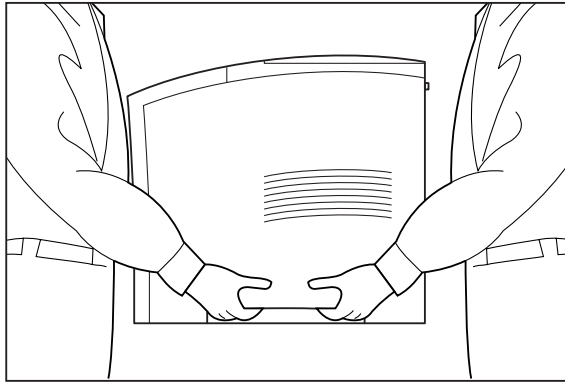

- To lift the printer, have two individuals facing each other from the front and the rear of the printer grasp the recessed areas on each side of the printer. Do not lift the printer by grasping any area other than these recessed areas.
- When lifting the printer, maintain proper lifting posture to prevent injuries.

### Moving the Printer a Short Distance

Use the following procedure to move the printer a short distance:

1. Turn the printer off by pressing the [ O ] on the power switch on the back of the printer.
2. Unplug the AC power cord from the AC wall outlet.
3. Disconnect the printer from the host computer.
4. Wait 30 minutes for the printer to cool.
  - Refer to Chapters 6 through 9 for instructions on moving installed paper-handling options.
6. Remove the toner cartridge and cover it with an opaque plastic sheet.
7. Move the printer to the new location.
8. Once the printer is in the new location, refer to the **Installation Guide** included in the original printer packaging for installation instructions.

### Moving the Printer a Long Distance

Use the following procedure to move the printer a long distance:

1. Turn the printer off by pressing the [ O ] on the power switch on the right side of the printer.
2. Unplug the AC power cord from the wall outlet and from the back of the printer.
3. Disconnect the printer from the host computer.
4. Remove the paper from all of the paper trays.
  - Wait 30 minutes for the printer to cool.

6. Remove all installed paper-handling options. Refer to Chapters 6 through 10 for instructions for removing installed paper-handling options.
7. Remove the toner cartridge and place it in an opaque plastic bag, then seal the bag with tape and place it in a sturdy box.
8. Repack the printer, paper trays, AC power cord and toner cartridge into the original shipping box or boxes.
9. Once the printer is in the new location, refer to the **Installation Guide** included in the original printer packaging for installation instructions.

### Storing the Printer for Long Periods of Time

If you will not be using the printer for several months, use the following procedure to prepare the printer for storage:

1. Turn the printer off by pressing the [ O ] on the power switch on the right side of the printer.
2. Unplug the AC power cord from the AC wall outlet.
3. Disconnect the printer from the host computer.
4. Remove the paper from all of the paper trays.
  - . If you will be storing the printer for six months or longer, remove the toner cartridge and place it in an opaque plastic bag, and seal the bag with tape.

---

**NOTE:** After prolonged inactivity the toner cartridge may degrade to the point where it is no longer usable and must be replaced. Poor print quality and frequent paper jams may indicate that the toner has solidified and that the drum has oxidized during storage.

---

6. Cover the printer with a plastic sheet and tape down the corners.
7. Store the printer in an area where the temperature and humidity are moderate, as described in “Environment” on page 1-5.

---

**NOTE:** Do not stack other items on top of the printer when storing the printer.

---



# Chapter 5

## Troubleshooting

### In this Chapter . . .

- “About this Chapter” on page 5-2
- “Installation Problems” on page 5-2
- “Paper Jams” on page 5-4
- “Print Image Quality Problems” on page 5-18
- “Miscellaneous Problems” on page 5-22
- “Warning Messages and Error Messages” on page 5-26

## About this Chapter

This chapter describes the problems that you may encounter when using your printer, and provides procedures for resolving the problems. This chapter also lists the warning and error messages that appear on the control panel display.

There are four basic types of printer problems:

- Installation problems

If there is a problem with the printer when you first turn it on, refer to “Installation Problems” on page 2 for information about possible installation problems.

- Paper Jams

If there is a paper jam, refer to “Paper Jams” on page 5-4 for procedures to remove the jam.

- Print quality problems

If the finished prints delivered to the output tray display image problems such as image black spots or vertical lines on the page, refer to “Print Image Quality Problems” on page 5-18 and complete the procedure provided for the specific image problem that you have encountered.

- Miscellaneous problems

If you have a printer problem but the control panel does not display a warning message or error message, refer to “Miscellaneous Problems” on page 5-22 and follow the directions for correcting that problem.

Many of these printer problems are indicated by a warning or error message appearing on the control panel display. If the printer control panel displays a warning message or error message, refer to “Warning Messages and Error Messages” on page 5-26 and complete the actions prescribed for the specific warning or error message.

## Installation Problems

It is common for simple oversights during printer installation to cause problems when you first turn the printer on, resulting in noise, smoke, or smell; an inoperative printer; or the absence of a ready message on the control panel.

### Inoperative Printer

If you have problems turning on the printer, check the possible causes listed in the table below. If the printer will not start after checking these items, turn the printer off, disconnect the power cord from the AC outlet, and contact your dealer or an authorized service provider.

Description	Possible Cause	Action
<b>There is no power.</b>	The power switch is not set to [ I ] (on).	Check the power switch. See "Step 7: Connecting the Power Cord and Turning the Printer On" on page 2-19. of the Installation Guide.
	The power cord is not properly plugged into an AC outlet or into the AC connector on the rear of the printer.	Set the power switch to [ O ] (off) and then connect the power cord firmly to the AC connector and to the AC outlet. See "Step 7: Connecting the Power Cord and Turning the Printer On" on page 2-19. of the Installation Guide.
	Voltage of the AC power is not correct.	Verify that the AC outlet is rated for the voltage of your printer.
	The fuse on the power cord is not functioning. (UK only)	Verify that the fuse on the power cord is intact. (UK only)
	The AC wall outlet is not functioning.	Verify that voltage is present at the AC wall outlet by connecting another electrical device to the outlet. If power does not flow to the other device, check the AC wall outlet circuit breakers for a tripped breaker.
	There is interference from other electrical devices on the same circuit.	Unplug all electrical devices from the AC wall outlet circuit, and then reconnect only the printer. Turn printer power on.
	Thermal sensors may have shut down the printer.	Turn the printer off and wait 20 minutes, then turn the printer back on.
<b>Power is frequently interrupted.</b>	The printer is malfunctioning.	Turn the printer off and disconnect the power cord from the AC outlet. Contact your dealer or an authorized service provider.

### No Ready Message

After warming up, the printer control panel displays the text "**Ready**", indicating that the printer is ready to print. If the printer does not show this message, but shows an error message instead, refer to "Warning Messages and Error Messages" on page 26 to determine the appropriate action for the specific error message that is shown. If the printer does not display either the "**Ready**" message or an error message, contact your retailer or sales representative.

### Noise, Smoke, or Smell

If you notice unusual noise, smoke, or smell after turning the printer on, *turn the printer off immediately and disconnect it from the AC wall outlet.* Use the following procedure to determine the cause of and alleviate the problem:

1. Refer to the pictorial unpacking sheet and the Installation Guide included in the printer packaging and make sure you have removed all shipping spacers and protective tape from the inside of the printer, the paper trays, and the toner cartridge.
2. Open the covers on the printer and carefully inspect the fuser area. Remove any pieces of paper that may be stuck in the fuser.
3. Check the inside of the printer for any obviously broken or detached parts. If you find a broken part, contact your retailer or sales representative.
4. Check the exterior of the printer for broken covers. If you find a broken cover, contact your retailer or sales representative.
  - . Verify that the AC wall outlet is the correct voltage for your printer.
6. Remove any paper you have loaded in the main tray, check the inside of the tray well for stray sheets of paper, and reload the paper into the main tray.
7. Connect the printer to the AC wall outlet and turn the printer on by pressing the [ I ] on the power switch on the right side of the printer.
8. If this procedure does not eliminate the noise, smoke or smell, or if the problem returns, turn the printer off, unplug the AC power cord from the AC wall outlet, and contact your retailer or sales representative.

## Paper Jams

Paper jams are generally the most common and reoccurring problem encountered when using any printer. Paper may jam anywhere along the paper path—from the paper tray to the output tray. Sensors within the printer constantly monitor paper travel, so when a sheet of paper fails to arrive at a certain point within a specific time, the printer interprets that to mean that the paper has stopped between two sensors along the paper path. The printer then displays a Paper Jam error message that corresponds to that specific jam.

When paper gets jammed inside the printer, printing stops and an error code indicating the position of the jam appears on the display.

Error Code	Paper Jam Location
E2	Between the paper feed section (front paper tray, main tray, or optional feeder tray) and the toner cartridge
E3	Between the toner cartridge and the fuser unit
E4	At the paper exit slot
E6	At the offset output tray
E7	At the duplexer



**Figure 1-4: Paper Jam Locations and Error Codes.**

The most common causes of paper jams are:

- The printer is not placed on a level surface.
- The print media does not conform to the specifications.
- The paper is not loaded correctly in the front paper tray or the cassette.
- The paper is wrinkled or curled.
- The paper guide is not set correctly.

**Occasional paper jams** result from simple things such as static electricity sticking paper together—causing several sheets to feed at the same time—or from the feed rolls becoming slippery from an accumulation of paper dust. Occasional paper jams usually require minor user intervention that involves reloading the paper or cleaning the feed rolls.

**Frequent paper jams** can be caused by anything from foreign material in the paper path to a malfunctioning component. Frequent paper jams may require involved user intervention that

### Clearing an E2 Paper Jam

If an E2 error code precedes the error message on the first line of the control panel display, paper has jammed somewhere between the feed area and the registration sensor. Use the following procedure to clear a paper jam in this location:

1. Remove any printed pages from the output tray.
2. If the jam occurred while feeding from the front paper tray, remove all paper from the front tray, including any paper that may be jammed inside the tray.

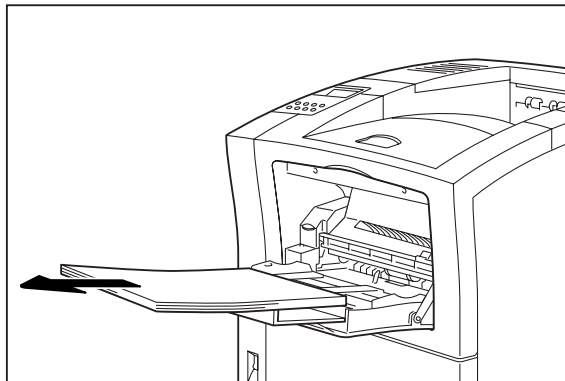
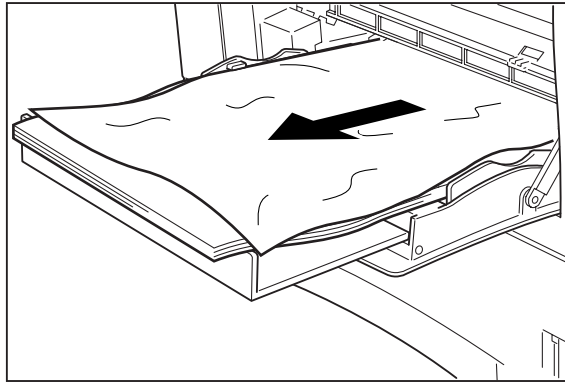

3. If the jam occurred while feeding from the main paper tray, remove the main paper tray.

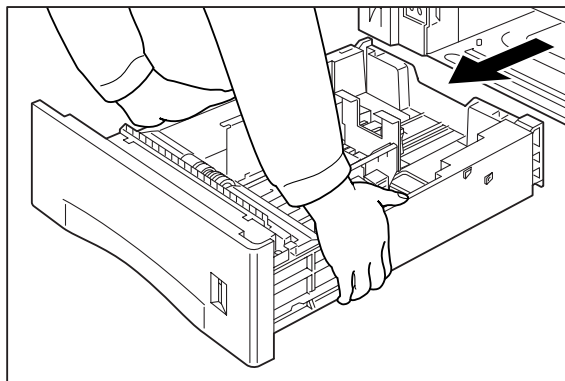

4. Remove any jammed or wrinkled paper from the paper tray.

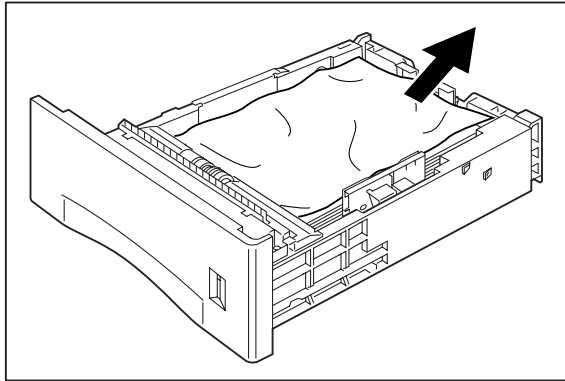

5. Remove any jammed paper from the inside of the paper tray well.
6. If the jam occurred while feeding from Tray 2 or 3, remove the paper tray associated with that feeder and remove any jammed paper.

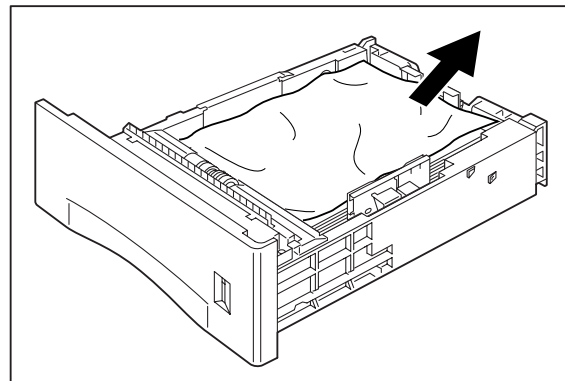
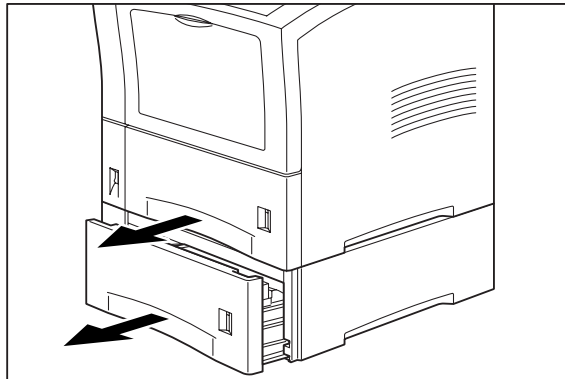

7. Remove any jammed paper from the inside of the paper tray well.

8. Insert each paper tray into the appropriate paper tray well, either on the optional feeder or on the printer.

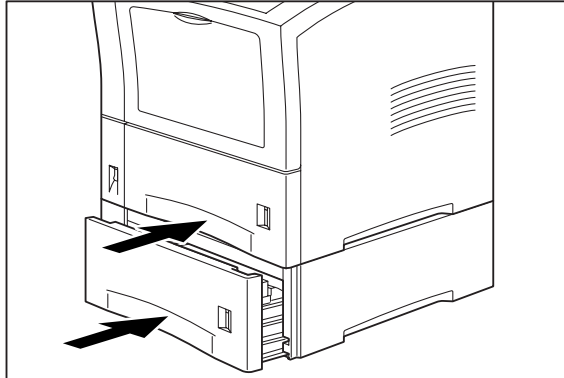

9. If the front tray is open, close it. Then pull on the recessed area on the front cover to open it.

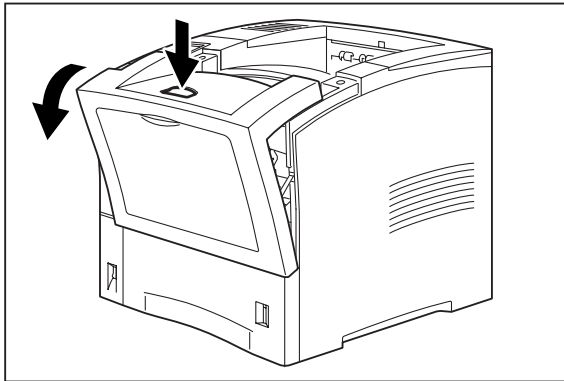

10. Return the front cover to its original position, pressing on the center of the cover to close it securely.

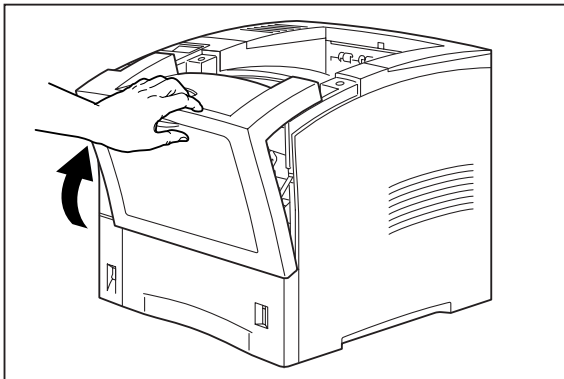

### Clearing an E3 Paper Jam

If an E3 error message appears on the printer display, there is a paper jam between the toner cartridge and the paper exit slot. Use the following procedure to remove a paper jam from this location.

1. Remove any printed sheets from the output tray.

2. Remove all paper from the front tray.
3. Press the button on the top of the front cover to release the cover, and open the front cover.

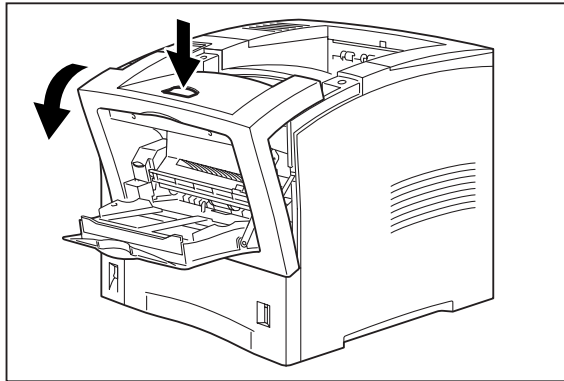

4. Remove the toner cartridge from the inside of the printer.

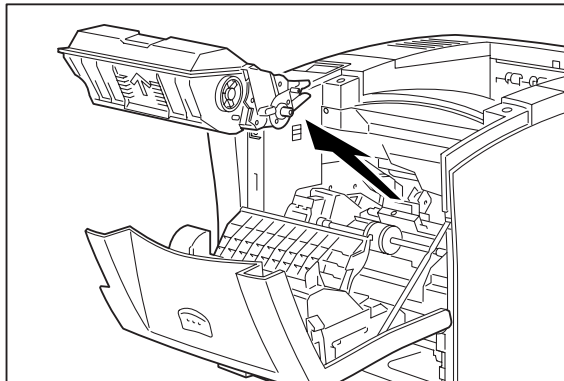

---

**NOTE:** To prevent stains, place the toner cartridge on a surface covered with newspaper or other disposable material.

---

5. Lift up on the lever on the left side of the inside of the printer, and fold the cover toward you. Remove any jammed paper.

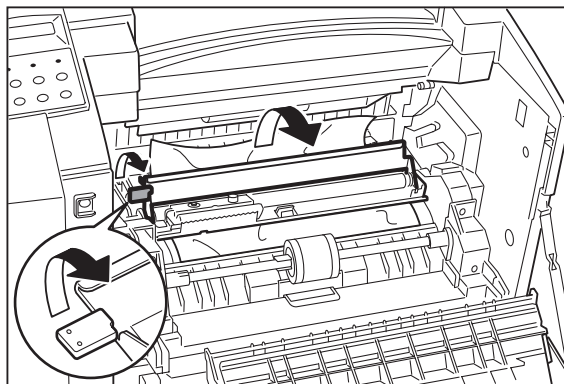

6. Insert the pegs on the sides of the toner cartridge into the channels on the inside of the printer, and push the cartridge into the printer.

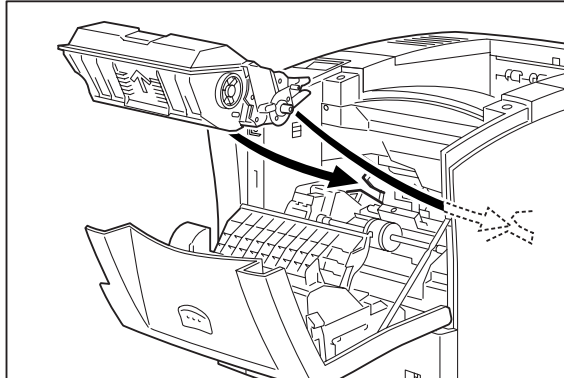

7. Close the front cover, pressing on the center of the front cover until it closes securely.

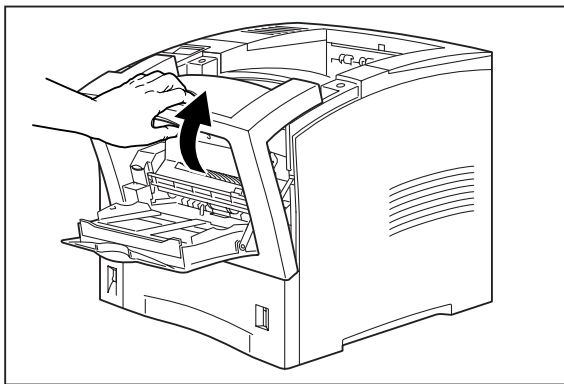

### Clearing an E4 Jam

If an E4 error code precedes the error message on the first line of the control panel display, paper has jammed somewhere near the paper exit slot. Use the following procedure to clear a paper jam in this location:

1. If you are using the paper tray in its extended position, remove it from the printer.

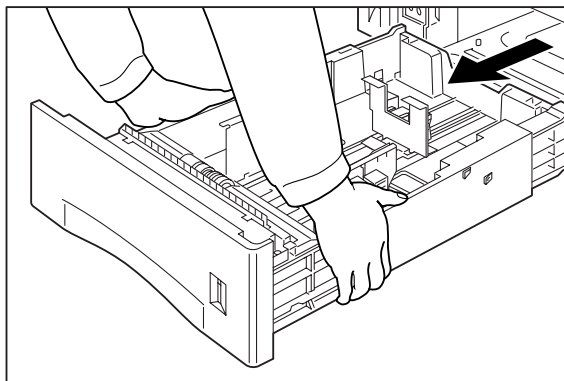

2. Squeeze the tabs on the top rear of the printer and pull the r

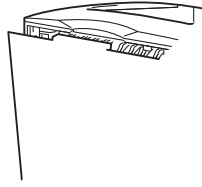

3. If there is par

- . If there is paper jammed around the fuser unit, lift up the fuser unit release levers on the left and right sides of the fuser and remove the jammed paper.

6. Return the fuser release levers to their original position.
7. If you removed the duplexer, insert the duplexer into the printer.

8. Push the green tabs at the sides of the duplexer out toward the sides of the printer.



9. Close the rear cover.

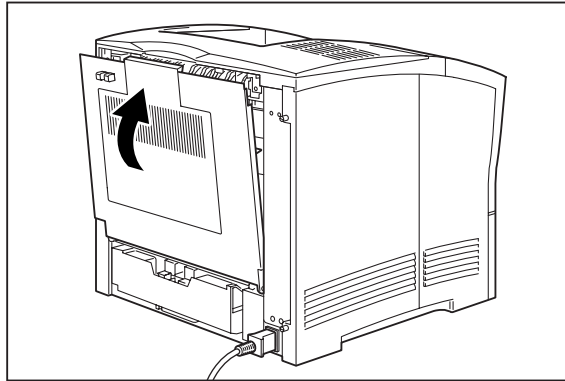

### Clearing an E7 Paper Jam

When an E7 error message is shown on the display screen, there is a paper jam in the duplexer. Use the following procedure to clear a duplex paper jam:

1. If you are using the paper tray in its extended position, remove the paper tray from the printer.



2. Squeeze the tabs on the rear of the printer and pull the rear cover toward you to open it.

3. Remove any jammed paper from the duplex area.

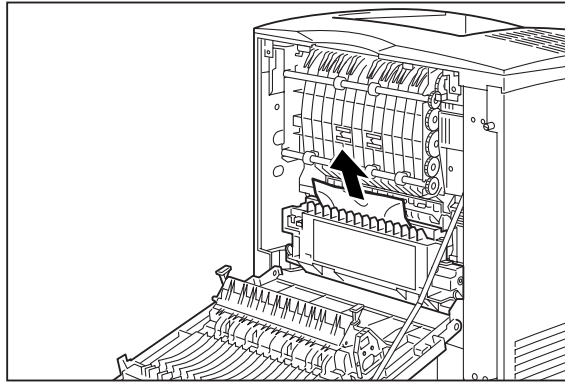

4. Push the green tabs on the sides of the duplexer toward the center of the duplexer, and grasp the recessed areas on the sides of the duplexer and remove it from the printer.

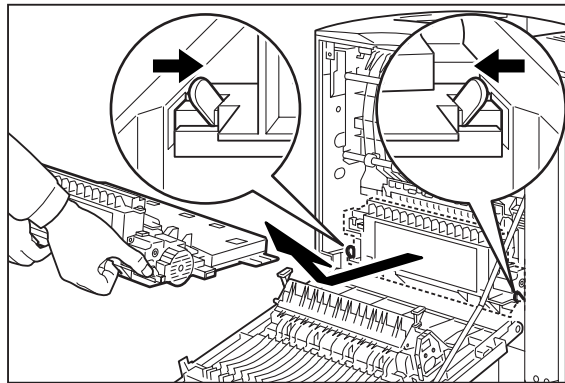

5. Push the tabs labelled 1 below out toward the sides of the duplexer, and open the duplexer.

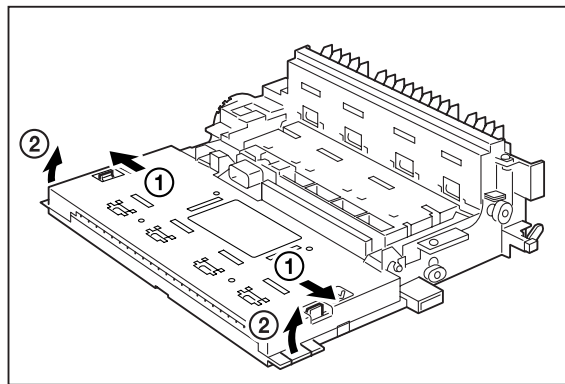

6. Remove any jammed paper from inside the duplexer unit.

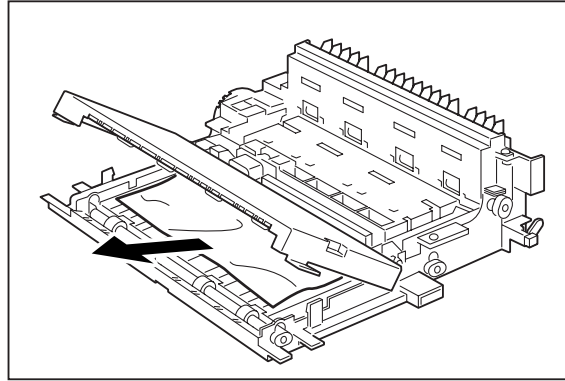

7. Slide the tabs on the left and right sides of the duplexer into the channels inside the printer, and push the duplexer completely into the printer.

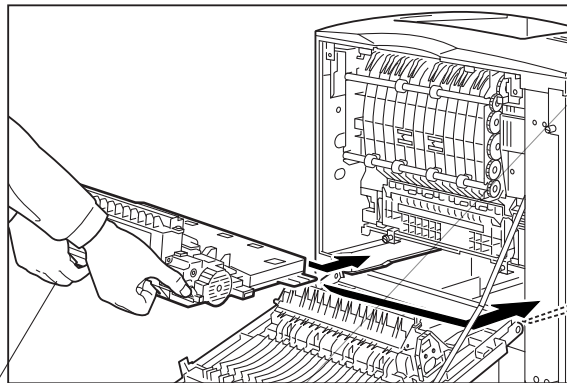

8. Push the green tabs on the sides of the duplexer out toward the sides of the printer to secure the duplexer to the printer.

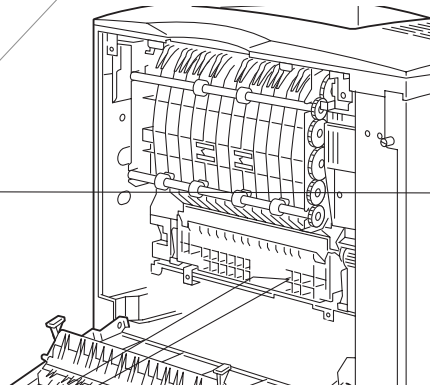

9. Close the rear cover.

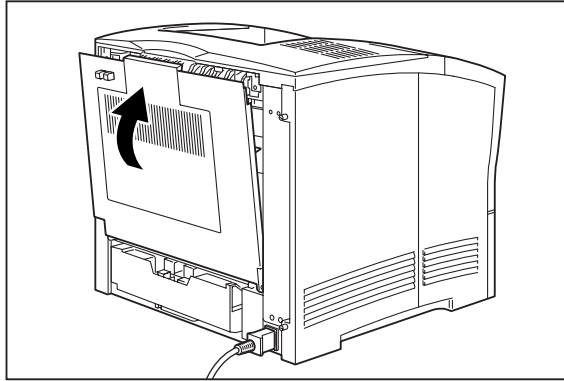

### Clearing an E6 Paper Jam

If an E6 error code precedes the error message on the first line of the control panel display, paper has jammed at the offset catch tray. Use the following procedure to clear a paper jam in this location:

1. Pull on the recessed area on the rear of the offset catch tray to open the rear cover.

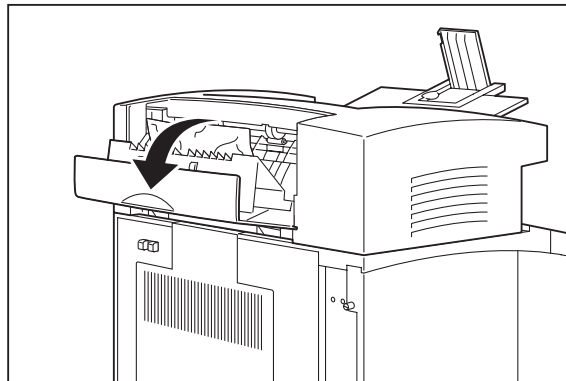

2. Remove any jammed paper from the interior of the offset catch tray.

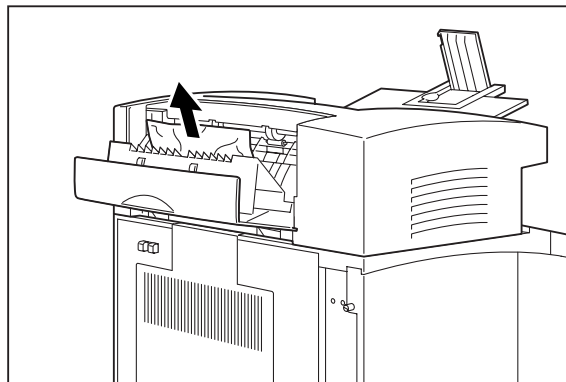

3. Close the rear cover of the offset catch tray.

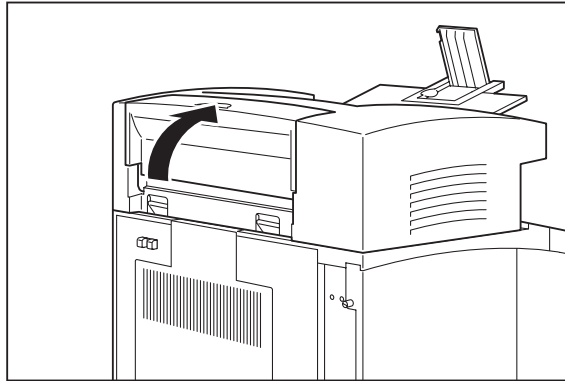

4. Squeeze the latch on the upper part of the rear cover, and pull the cover toward you to open it. If there is paper jammed in the space behind the rear cover, remove it.

---

**NOTE:** If the paper tray is in the extended position, remove the tray before opening the rear cover.

---

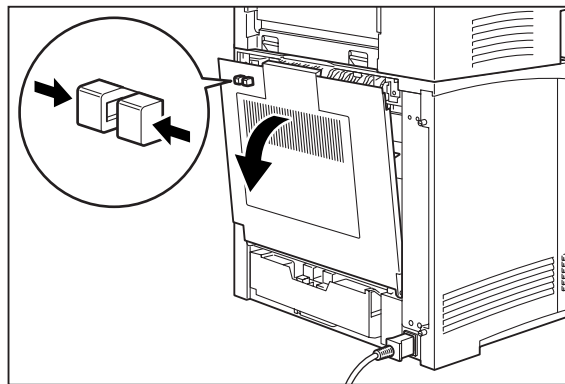

- . Close the rear cover.

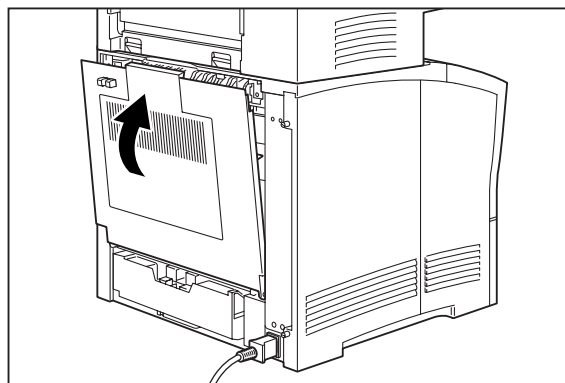





## Print Image Quality Problems



When functioning correctly, the printer should produce printed paper that is relatively flat and undamaged, containing a fused image of correct intensity—without streaks, smears, spots, or missing areas. If the printed sheets that your printer produces do not meet these qualifications, there is a print image quality problem.

- **Minor Print Image Quality Problems** can be caused by exhausted or damaged consumables, such as the toner cartridge. These problems are easily corrected by simply replacing the consumable.
- **Major Print Image Quality Problems** can be caused by a malfunctioning or broken component. These problems may require you to call a service technician to determine and correct the problem.

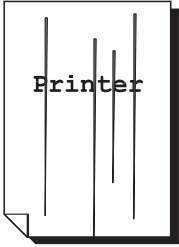
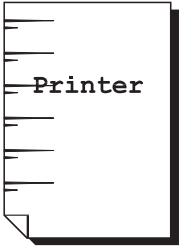
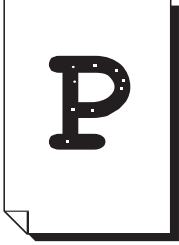

This section describes possible quality problems during printing. Go through the list below to find the condition that most resembles the problem, and follow the recommended action. If the trouble persists, turn the printer off and disconnect the power cord from the AC outlet. Then contact your dealer or an authorized service provider.

Description	Possible Cause	Action
<p><b>Faded print</b></p> 	<p>The print media is moist.</p> <p>The toner cartridge is old or damaged.</p> <p>Toner in the toner cartridge is low.</p>	<p>Remove the moist media and load new, dry media.</p> <p>Replace the toner cartridge.</p> <p>Replace the toner cartridge.</p>
<p><b>Black dots</b></p> 	<p>The print media is outside the recommended specifications.</p> <p>The toner cartridge is old or damaged.</p>	<p>Use the recommended print media.</p> <p>Replace the toner cartridge.</p>

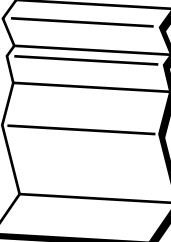
<p><b>Vertical black streaks</b></p> 	<p>The toner cartridge is old or damaged.</p>	<p>Replace the toner cartridge.</p>
<p><b>Repetitive defects</b></p> 	<p>The paper path is dirty.  The toner cartridge is old or damaged.</p>	<p>Print out several blank sheets.  Replace the toner cartridge.</p>
<p><b>Character voids</b></p> 	<p>The print media is outside the recommended specifications.  The toner cartridge is old or damaged.</p>	<p>Use the recommended print media.  Replace the toner cartridge.</p>
<p><b>Toner smears when rubbed</b></p> 	<p>The print media is moist.  The print media is outside the recommended specifications.  The front cover not fully closed.</p>	<p>Remove the moist media and load new, dry media.  Use the recommended print media.  Close the front cover properly.</p>

<p><b>Black page</b></p> 	<p>The toner cartridge is old or damaged.</p> <p>The high-voltage power supply may be defective.</p>	<p>Replace the toner cartridge.</p> <p>Contact your dealer or an authorized service provider.</p>
<p><b>Blank page</b></p> 	<p>The sealing tape of the toner cartridge is not pulled out.</p> <p>The printer feeds two or more sheets at a time.</p> <p>The toner cartridge is old or damaged.</p> <p>The toner in the toner cartridge is low.</p> <p>The high-voltage power supply may be defective.</p>	<p>Pull out the sealing tape.</p> <p>Avoid adding paper to a nearly full stack.</p> <p>Replace the toner cartridge.</p> <p>Replace the toner cartridge.</p> <p>Contact your dealer or an authorized service provider.</p>
<p><b>Partial blanks</b></p> 	<p>The print media is moist.</p> <p>The print media is outside the recommended specifications.</p> <p>The sealing tape of the toner cartridge is not fully pulled out.</p>	<p>Remove the moist media and load new, dry media.</p> <p>Use the recommended print media.</p> <p>Replace the toner cartridge.</p>
<p><b>Creased paper</b></p> 	<p>The print media is outside the recommended specifications.</p> <p>The print media is moist.</p>	<p>Use the recommended print media.</p> <p>Remove the moist media and load new, dry media.</p>

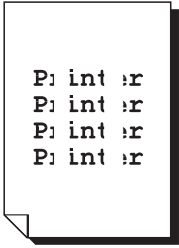

<p><b>Plotted print</b></p> 	<p>The print media is outside the recommended specifications.</p> <p>The print media is moist.</p> <p>The toner cartridge is old or damaged.</p>	<p>Use the recommended print media.</p> <p>Remove the moist media and load new, dry media.</p> <p>Replace the toner cartridge.</p>
<p><b>Vertical blanks</b></p> 	<p>The toner cartridge is not installed correctly.</p> <p>The toner cartridge is old or damaged.</p>	<p>Remove the toner cartridge and reinstall it.</p> <p>Replace the toner cartridge.</p>
<p><b>Blurred print</b></p> 	<p>The toner cartridge is old or damaged.</p>	<p>Replace the toner cartridge.</p>
<p><b>Bold print appears shaded</b></p> 	<p>The toner cartridge is old or damaged.</p>	<p>Replace the toner cartridge.</p>

**Other Print Image Quality Problems**

The following characteristics define this print image problem:

- The finished print has a problem that is not identified by any of the other procedures in this manual.

- The control panel does not display an error code.

The following procedure guides you through multiple actions that may solve this print image quality problem. Proceed one step at a time until the problem is solved—you may not need to complete the entire procedure. If one of the steps in this procedure corrects the problem but the identical problem returns in less than 50 prints, call for service.

1. Replace all of the paper in the paper trays with newly opened paper.

The paper in the trays may be damp or damaged, resulting in poor image quality. New paper may correct the problem.

2. Replace the toner cartridge with a new one.

The toner cartridge may have reached end of life or is damaged.

3. Disconnect then reconnect the interface cable that runs between the printer and the host computer.

There may be a bad connection between the printer and the computer. Reconnecting both ends should reestablish a good electrical connection. If you have another interface cable available, substitute that cable for the one currently connecting the printer and the computer.

4. Reinstall the print driver software.

The print driver software that is running on the host computer may be damaged. Reinstalling the software is an easy and inexpensive way to isolate or eliminate the source of the problem. Refer to the DRIVERS folder on the electronic library CD-ROM for detailed instructions on installing the driver.

- Call your service technician.

This image quality problem may be caused by a malfunctioning or broken component that requires service.

## Miscellaneous Problems

Some printer problems may not generate error codes or produce observable print image defects. These miscellaneous problems may effect only the printer or they may effect things outside of the printer, such as the room lights or a nearby radio receiver.

This section contains detailed procedures for correcting the following problems:

- **Printer is Inoperative**
- **Printer Operates Erratically**
- **Printer Makes Unusual Noises**
- **Room Lights Dim or Flicker When Printer Starts**
- **Printer Interferes with Nearby Radio or Television Reception**

### Printer is Inoperative

The following characteristics define this type of problem:

- The printer appears to have no power.
- The control panel does not light up or display characters.

- The printer motors do not run and the printer does not warm up.
- The control panel does not display an error code.

The following procedure guides you through multiple actions that may solve this print image quality problem. Proceed one step at a time until the problem is solved—you may not need to complete the entire procedure. If one of the steps in this procedure corrects the problem but the identical problem returns in less than 50 prints, call for service.

1. Make sure that you push the [ I ] on the main power switch to turn on the printer.
2. Check to make sure the AC power cord is firmly plugged into the AC wall outlet and that the other end of the AC power cord is firmly plugged into the printer.

Sometimes the AC power cord is only partially plugged in and is not making good electrical contact. If the AC power cord keeps working loose you might consider moving the printer to a safer location. If the AC wall outlet is broken, allowing the power cord to easily fall out, replace the outlet.

3. Test for voltage present by plugging an AC electrical device, such as a lamp, into the AC wall outlet. If the lamp does not light, inspect the building circuit breakers or check for a broken AC wall outlet.

A circuit breaker trips because there was an overload on the line. A tripped breaker may indicate that you have too many AC devices working off the same line or that you have faulty building wiring. If the breaker is not tripped, but the lamp doesn't light when plugged into the outlet, replace the outlet or have an electrician check the line.

4. Turn the printer off and wait 20 minutes, then turn the printer on.

Thermal sensors may have shut down the printer. Waiting 20 minutes for the printer to reset may return the printer to normal operation. A thermal shutdown may indicate there is a more serious problem with the printer. If the problem reoccurs, call for service.

- Call your service technician.

This problem may be caused by a malfunctioning or broken component that requires service.

### Printer Operates Erratically

The following characteristics define this type of problem:

- The printer does not function correctly.
- The printer may go into frequent warm-up.
- The control panel may display garbled characters.
- The printer may lose power or stop printing for no apparent reason.
- The control panel does not display an error code.

The following procedure guides you through multiple actions that may solve this print image quality problem. Proceed one step at a time until the problem is solved—you may not need to complete the entire procedure. If one of the steps in this procedure corrects the problem but the identical problem returns in less than 50 prints, call for service.

1. Check to make sure the AC power cord is firmly connected to the AC wall outlet and that the other end of the AC power cord is firmly connected to the printer.

A loose or partially connected AC power cord may cause erratic operation. If the AC power cord is repeatedly loose or disconnected, you may consider moving the printer to a safer location. If the AC wall outlet is broken, allowing the power cord to easily fall out, replace the outlet.

2. Check to make sure the computer interface cable is firmly connected to the printer and that the other end of the cable is firmly connected to the computer.

There may be a bad connection between the printer and the computer. Reconnecting both ends should reestablish a more reliable electrical connection. If you have another interface cable available, substitute the new cable for the one currently connecting the printer and computer.

3. Open and then firmly close all printer doors and covers.

Interlock switches monitor the position of printer doors and covers for safety reasons. When a door is closed, the interlock switch is activated and the printer can operate. When a door is open, the interlock switch is not activated and the printer cannot operate. If a door is not firmly closed, the interlock switch can bounce between being activated and being not activated—confusing the system and causing erratic printer operation.

4. Reinstall the print driver software.

The print driver software that is running on the host computer may be damaged. Reinstalling the software is an easy and inexpensive way to isolate or eliminate the problem. Refer to the DRIVERS folder on the Electronic Library CD-ROM for detailed instructions on installing the driver.

5. Unplug the AC power cord from the AC wall outlet. Plug a 100 watt lamp into the AC wall outlet and watch the lamp for 30 minutes. If the lamp flickers noticeably or dims then brightens, you should replace the outlet or have an electrician check the line.

Voltage surges or drops at the AC wall outlet can cause sensitive printer components to function erratically. In some instances wide voltage swings can seriously damage the printer.

6. Call your service technician.

This problem may be caused by a malfunctioning or broken component that requires service.

### Printer Makes Unusual Noises

The following characteristics define this type of problem:

- The printer makes unusual noises or makes more noises than usual either while idle or while printing.
- The printer generates printed sheets without a problem.
- The control panel does not display an error code.

The following procedure guides you through multiple actions that may solve this print image quality problem. Proceed one step at a time until the problem is solved—you may not need to complete the entire procedure. If one of the steps in this procedure corrects the problem but the identical problem returns in less than 50 prints, call for service.

1. Turn the printer off and open all of the printer access covers. Inspect the interior of the printer for pieces of paper or obviously broken components that could be causing the noise. Remove any paper that you find. If you see a broken component, call for service.

Broken and dangling components or scraps of paper lodged inside the printer may be brushing against moving parts and causing the noise.

2. Inspect the fan outlets for broken grills or objects stuck in the fans. Remove any objects from the fan grill. If you see a broken grill or cover, call for service.

An object or part of a broken fan grill may be brushing against the fan and causing the noise. A broken fan grill is a potential safety hazard and should be replaced.

3. Call your service technician.

This problem may be caused by a malfunctioning or broken component that requires service.

### Room Lights Dim or Flicker When Printer Starts

The following characteristics define this type of problem:

- Nearby lights dim slightly or flicker when you first turn on the printer or when the printer begins printing.
- The lights remain normal when the printer is not on.
- The printer generates printed sheets without a problem.
- The control panel does not display an error code.

The following procedure guides you through multiple actions that may solve this print image quality problem. Proceed one step at a time until the problem is solved—you may not need to complete the entire procedure. If one of the steps in this procedure corrects the problem but the identical problem returns in less than 50 prints, call for service.

1. Unplug all devices that are plugged into the same AC wall outlet as the printer.

During warm-up and at the start of each print run, the printer normally draws a large amount of current. If other devices are running off of the same AC circuit, the accumulative current draw may result in nearby lights momentarily dimming.

2. Have an electrician check your building wiring.

There may be a problem with the AC outlet or the AC wiring in the building that needs the attention of a licensed electrician.

3. Call your service technician.

This problem may be caused by a malfunctioning or broken component that requires service.

### Printer Interferes with Nearby Radio or Television Reception

The following characteristics define this type of problem:

- When the printer begins printing, it causes audio noise in nearby radios or interferes with the picture in nearby televisions.
- The printer generates printed sheets without a problem.
- The control panel does not display an error code.

The following procedure guides you through multiple actions that may solve this print image quality problem. Proceed one step at a time until the problem is solved—you may not need to complete the entire procedure. If one of the steps in this procedure corrects the problem but the identical problem returns in less than 50 prints, call for service.

1. If the radio/television is plugged into the same AC wall outlet as the printer, plug either the printer or the radio/television into another AC outlet.

Electrical noise may be transmitted through the AC line. You can reduce the noise to the radio/television by using a dedicated AC wall outlet for the printer.

2. Move the radio/television away from the printer.

Your printer complies with the FCC rules regarding radio/television interference caused by digital devices. This printer generates, uses, and may radiate low levels of radio frequency energy that could interfere with radio and television reception in some installations. Increasing the distance between the printer and the radio/television is a very effective method for reducing minor interference.

3. Identify the building circuit breaker that controls the AC outlet to your printer. Identify all of the AC outlets that are controlled by that circuit breaker. Unplug all devices from the AC outlets that are controlled by that circuit breaker, except for the printer.

Electrical noise may be transmitted through the AC line. In difficult interference cases you may have to dedicate an entire AC line to the printer.

4. Call your service technician.

This problem may be caused by a malfunctioning or broken component that requires service.

## Warning Messages and Error Messages

The control panel display shows a warning message or error message when there is a problem with the printer. Some messages indicate routine status conditions such as an empty paper tray, while others indicate that a sheet of paper has jammed in a specific area of the printer. Some messages indicate more serious printer problems that may require the help of a service technician.

Warning messages use only the second line of the display and indicate conditions that do not prevent the printer from operating. For example, if Tray 1 is out of paper but the printer is currently drawing paper from Tray 2, a warning message will appear on the second line of the display indicating that Tray 1 is out of paper—but the printer will continue to operate, drawing paper from Tray 2.

Error messages use both lines of the display and indicate conditions that prevent the printer from operating. The first line of an error message contains the error code and type of error, while the second line of the display contains information about the action required to recover from the error.

When the control panel displays a warning or error message, refer to the fn-231.9478 TD5.8(s)-2rg atables-258.3(c)

## Warning Messages

The following table lists warning messages, possible causes, and the actions required to correct each cause.

<b>Warning Message Line 2 of display</b>	<b>Possible Cause</b>	<b>Action</b>
Paper Out Tray 1	There is no paper in Tray 1.	Add paper to the tray.
Paper Out Tray 2	There is no paper in Tray 2.	Add paper to the tray.
Paper Out Tray 3	There is no paper in tray 3.	Add paper to the tray.
Output Tray Full	The output tray is full.	Remove paper from the tray.
Offset Tray Full	The offset output tray is full.	Remove paper from the tray.
Toner Low	The toner is low.	Replace the toner cartridge soon.
Maintenance Req	Maintenance is required.	Call service.

## Error Messages

The table below lists error messages, the possible causes of each error, and the actions required to recover from each error.

Error Message Line 1	Error Message Line 2	Possible Cause	Action
<b>E2 JAM MISFEED E3 JAM FUSER E4 EXIT JAM E6 JAM OFF. TRAY E7 JAM DUPLEX</b>	Remove Paper	There is a paper jam inside the printer.	Remove the jammed paper from the indicated location. See the "Paper Jams" on page 5-4 for information about removing paper jams.
<b>E5 COVER OPEN</b>	Close Top Cover	The top cover is open.	Close the top or rear cover.
<b>E5 COVER OPEN</b>	Close Rear Cover	The rear cover is open.	Close the offset tray cover.
<b>J3 TONER CART.</b>	Install/Reset	The toner cartridge is not installed, or an incorrect cartridge is installed.	Install the correct toner cartridge according to the specifications. See "Replacing the Toner Cartridge" on page 4-3.
<b>TRAY 1 MISSING</b>	Insert Tray	Tray 1 is not in the printer.	Insert the tray.
<b>TRAY 2 MISSING</b>	Insert Tray	Tray 2 is not in the optional feeder.	Insert the tray.
<b>TRAY 3 MISSING</b>	Insert Tray	Tray 3 is not in the optional feeder.	Insert the tray.
<b>LOAD PAPER TRAY1</b>	Paper Size/ Paper Type	Tray 1 is empty.	Load paper into the tray.
<b>LOAD PAPER TRAY2</b>	Paper Size/ Paper Type	Tray 2 is empty.	Load paper into the tray.
<b>LOAD PAPER TRAY3</b>	Paper Size/ Paper Type	Tray 3 is empty.	Load paper into the tray.
<b>LOAD PAPER FRONT</b>	Paper Size/ Paper Type	The front tray is empty.	Load paper into the tray.
<b>PAPER SIZE ERROR</b>	Paper Size/ Press Start	The paper size is not supported by the printer.	Check paper size specifications and load paper that meets specifications.
<b>OUTPUT TRAY FULL</b>	Remove Paper	The output tray is full.	Remove paper from the tray.
<b>OFFSET TRAY FULL</b>	Remove Paper	The offset output tray is full.	Remove paper from the tray.
<b>PAPER PATH ERROR</b>	Close Face Up	The face up tray is open.	Close the face up tray.



<b>Error Message Line 1</b>	<b>Error Message Line 2</b>	<b>Possible Cause</b>	<b>Action</b>
<b>U2 ROS FAILURE</b>	Call Service	The ROS has failed.	Turn the printer off, then turn it on. If the problem reoccurs, contact an authorized service provider.
<b>U4 FUSER FAILURE</b>	Call Service	The fuser has failed.	
<b>ENV UNIT FAILURE</b>	Chk Feeder	The envelope unit was removed or has failed.	
<b>OFFSET TRAY FAIL</b>	Call Service	The offset tray was removed or has failed.	
<b>OPTION TRAY FAIL</b>	Call Service.	One of the optional trays has failed.	
<b>DUPLEX FAILURE</b>	Call Service	The duplexer was removed or has failed.	
<b>MAIN MOTOR FAIL</b>	Call Service	The main motor has failed.	
<b>ENGINE NV FAIL</b>	Call Service	The engine has failed.	
<b>FAN FAILURE</b>	Call Service	The fan has failed.	
<b>MAINTENANCE REQ</b>	Press Start	The printer needs maintenance.	Press the START button.





# Chapter 6

## Using the Duplexer

### In this Chapter . . .

- “About this Chapter” on page 6-2
- “About the Duplexer” on page 6-2
- “Installing the Duplexer” on page 6-2
- “Testing the Duplexer” on page 6-4
- “Solving Duplexer Problems” on page 6-6
- “Removing the Duplexer” on page 6-13

## About this Chapter

This chapter provides all of the information necessary to install, use, and maintain the duplexer.

## About the Duplexer

The duplexer is a customer-installed optional device that allows the printer to print on both sides of a sheet of paper. The duplexer transports the paper in the paper path, then reverses the direction of transport, then reverses the direction of transport, then reverses the direction of transport. The printer can image both sides of a sheet of paper (sides 1 and 3) then refer to the other side of the sheet.

### Major Components

The following figure

the duplexer from  
that you have received t

Figure 6-1: Contents of Duplexer Shipping Box.

g procedure to install the duplexer:

AC wall outlet.

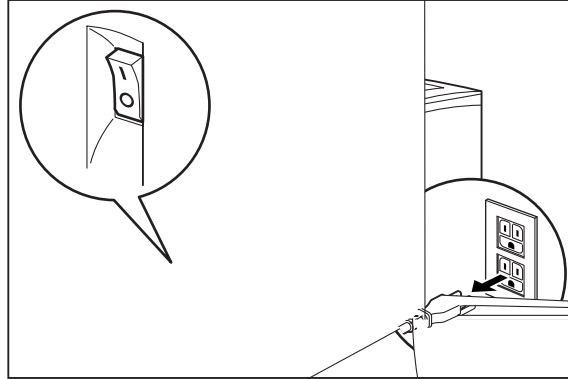

is extended position,

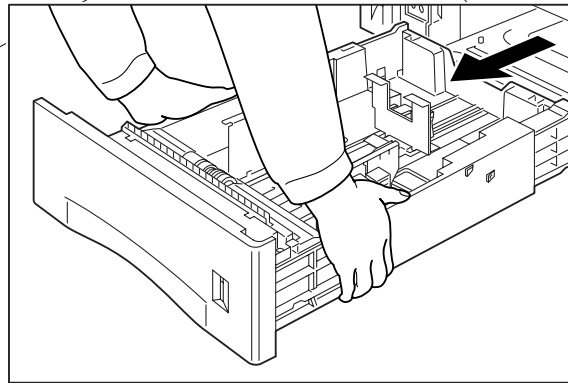

3. Squeeze the tabs on the left rear of the printer and pull the rear cover toward you to open it.

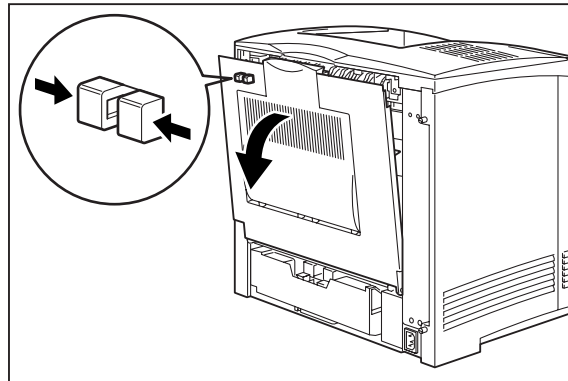

4. Slide the tabs on the left and right sides of the duplexer into the channels inside the printer, and push the duplexer completely into the printer.



5. Push the green tabs on the sides of the duplexer out toward the sides of the printer to secure the duplexer to the printer.

6. Close the rear cover.

## Testing the Duplexer

After installing the duplexer, use the following procedure to make sure it transports paper correctly:

1. Turn the printer on by pressing the [ I ] on the power switch on the right side of the printer.

2. Once the printer has warmed up and displays the “Ready” message on the control panel display, use any software application to print a few duplexed sheets.
3. If the duplexer does not transport paper or if the control panel shows an error message, refer to “Solving Duplexer Problems” on page 6-6.

## Solving Duplexer Problems

When there is a problem with the duplexer, the printer control panel displays an error code and error message. Most duplexer error codes indicate routine status conditions such as a paper tray running out of paper or a paper jam in a specific area of the duplexer. Some error codes indicate much more serious problems that may require the help of a service technician.

- If the duplexer is inoperative after installation, refer to “**Installation Problems**” on page 6-6 and complete the recommended procedure.
- If the printer control panel displays an error message or an error code, refer to “**Interpreting Duplexer Error Codes**” below.
- If you have a duplexer problem but the printer control panel does not display an error message or error code, refer to “**Correcting Miscellaneous Duplexer Problems**” on page 6-10 and follow the directions for correcting that problem.

### Interpreting Duplexer Error Codes

The printer control panel displays error messages when there is a problem with the printer or any of the optional paper-handling components. The following table lists all of the error messages associated with the duplexer, the possible cause of the error, and the action to take to correct the problem. If the control panel shows an error message that concerns another part of the printer, refer to **Chapter : Troubleshooting** for a complete list of all warning and error messages.

Error Message Line 1	Error Message Line 2	Possible Cause	Action
<b>E7 JAM DUPLEX</b>	Remove paper	There is a paper jam in the duplexer.	Remove the jammed paper from the duplexer. <b>See “Clearing Duplex Paper Jams” on page 6-7.</b>
<b>DUPLEX FAILURE</b>	Call Service	The duplexer has failed.	Turn the printer off, then turn it on. If the problem reoccurs, contact an authorized service provider.

### Installation Problems

Simple oversights during installation may cause problems when you first use the duplexer. If the duplexer is inoperative after you have installed it, use the following procedure to check several possible causes.

1. Turn the printer off by pressing the [ O ] on the power switch on the right side of the printer.
2. Make sure that the duplexer is firmly seated inside the printer.
3. If the connector is firmly seated in the printer, but the duplexer is still inoperative, return to “**Installing the Duplexer**” on page 6-2 and carefully repeat all of the installation steps.
4. If the duplexer is still inoperative after reinstallation, remove it from the printer so you can run tests on the printer without the duplexer affecting the tests.
  - Print a few sheets of text or images to make sure the printer is still operational.

If the printer is operational when the duplexer is removed, contact either your sales representative or a service provider and report your problem.



If the printer is not operational after you have removed the duplexer, refer to **Chapter : Troubleshooting**. After correcting the printer problem, return to “Installing the Duplexer” on page 6-2 and reinstall the duplexer.

### Clearing Duplex Paper Jams

When an E7 error message is shown on the display screen, there is a paper jam in the duplexer. Use the following procedure to clear a duplex paper jam:

1. If you are using the paper tray in its extended position, remove the paper tray from the printer.

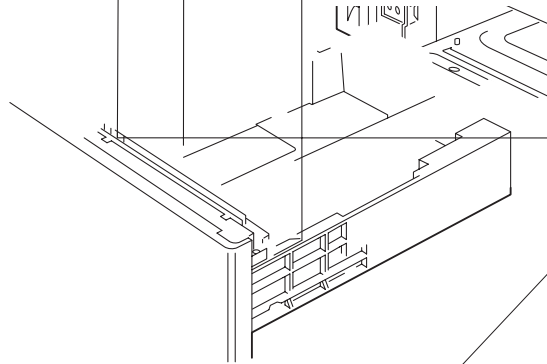

2. Squeeze the tabs on the rear of the printer and pull the rear cover toward you to open it.





The green ta  
duplexer to th

Mar 00

Publication No. GEG-99054

9. Close the rear cover.

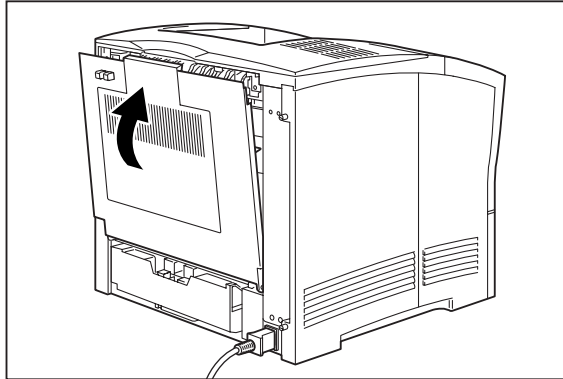

### Correcting Miscellaneous Duplexer Problems

Some duplexer problems may not cause an error message and may not interfere with the operation of the printer. If you are experiencing one of the problems listed below and there is no error message shown on the control panel display, refer to the procedures in the following sections to check the possible causes of the specific problem.

- Inoperative duplexer
- Erratic operation
- Unusual noise

#### *Inoperative Duplexer*

The following characteristics define this duplexer problem:

- The duplexer appears to be inoperative.
- When attempting to print duplexed sheets, the duplexer does not respond and does not feed paper.
- The control panel does not display an error code.

The following procedure guides you through multiple actions that may solve this duplexer problem. Proceed one step at a time until the problem is solved—you may not need to complete the entire procedure. If one of the steps in this procedure corrects the problem but the identical problem returns in less than 50 prints, call for service.

1. Open and then firmly close all of the printer doors and covers.

Interlock switches monitor the position of printer doors and covers. When a door is closed, the interlock switch is activated and the duplexer can operate. When a door is open, the interlock switch is not activated and the duplexer cannot operate. If a door is not firmly closed, the interlock switch may not be fully activated—resulting in an inoperative duplexer.

2. Test the printer by printing single-sided sheets from the main tray.

If you cannot print a sheet of paper from the main tray and the printer does not display an error code, go to “Inoperative Printer” on page 5-3. If you can print a sheet of paper from the main tray, proceed to the next step.

3. Open the rear cover of the printer. Remove and reinstall the duplexer.

If the connection between the duplexer and the printer is not intact, the duplexer will not receive power or logic commands, resulting in an inoperative duplexer

4. Examine the printer driver settings to make sure the duplexer is available as an installed option.

- . If the duplexer is correctly set as an installed option, reload the printer driver software.

The printer driver software running on the host computer may be damaged. Reinstalling the software is an easy and inexpensive way to isolate or eliminate the problem. Refer to the **DRIVERS** folder on the Electronic Library CD-ROM for detailed instructions on installing the driver.

6. Call your service technician.

This problem may be caused by a malfunctioning or broken component that requires service.

### *Duplexer Operates Erratically*

The following characteristics define this duplexer problem:

- The duplexer does not function correctly.
- The control panel does not display an error code.

The following procedure guides you through multiple actions that may solve this duplexer problem. Proceed one step at a time until the problem is solved—you may not need to complete the entire procedure. If one of the steps in this procedure corrects the problem but the identical problem returns in less than 50 prints, call for service.

1. Open the rear cover of the printer. Remove and reinstall the duplexer.

If the connection between the duplexer and the printer is not intact, the duplexer will not receive power or logic commands, resulting in an inoperative duplexer.

2. Test the printer by allowing it to run for a few days without the duplexer installed.

If the printer operates erratically when the duplexer is not installed, refer to “Printer Operates Erratically” on page 5-23.

If the printer does not operate erratically when the duplexer is not installed, reinstall the duplexer and proceed to the next step.

3. Open and then firmly close all of the doors and covers.

Interlock switches monitor the position of printer doors and covers. When a door is closed, the interlock switch is activated and the duplexer can operate. When a door is open, the interlock switch is not activated and the duplexer cannot operate. If a door is not firmly closed, the interlock switch can bounce between being activated and being not activated - confusing the system and causing erratic operation.

4. Reinstall the printer driver software.

The printer driver software running on the host computer may be damaged. Reinstalling the software is an easy and inexpensive way to isolate or eliminate the problem. Refer to the **DRIVERS** folder on the Electronic Library CD-ROM for detailed instructions on installing the drivers.

- . Call your service technician.

This problem may be caused by a malfunctioning or broken component that requires service.

### *Duplex Makes Unusual Noises*

The following characteristics define this duplexer problem:

- The duplexer makes unusual noises or makes more noise than usual either while idle or while printing.
- The duplexer feeds paper without a problem.
- The control panel does not display an error code.

The following procedure guides you through multiple actions that may solve this duplexer problem. Proceed one step at a time until the problem is solved—you may not need to complete the entire procedure. If one of the steps in this procedure corrects the problem but the identical problem returns in less than 50 prints, call for service.

1. Open the rear cover of the printer and inspect the inside of the duplexer for jammed paper or obviously broken components.

Broken components or scraps of paper lodged inside the duplexer may be brushing against moving parts and causing the noise.

2. Call your service technician.

This problem may be caused by a malfunctioning or broken component that requires service.

## Removing the Duplexer

Use the following procedure to remove the duplexer:

1. Turn off the printer and disconnect the AC power cord from the AC wall outlet..

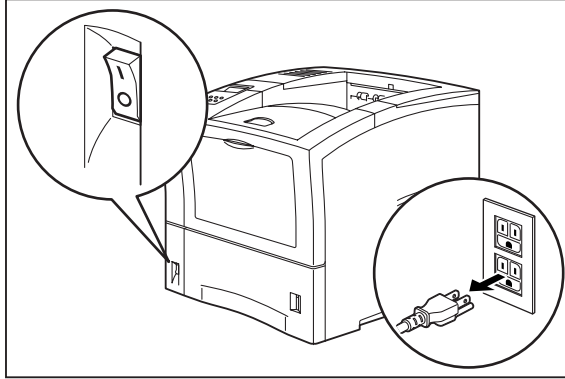

2. If you are using the paper tray in its extended position, remove the paper tray from the printer.

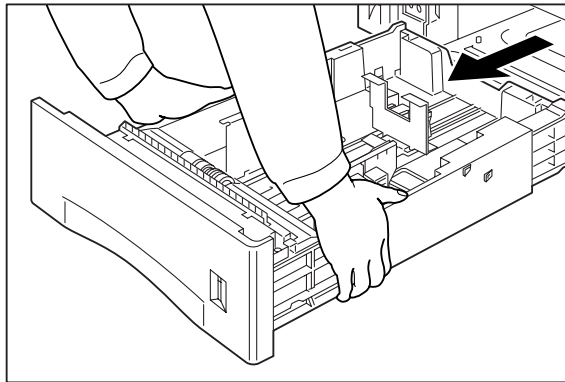

3. Squeeze the tabs on the top left of the rear cover, and pull the cover to open it.

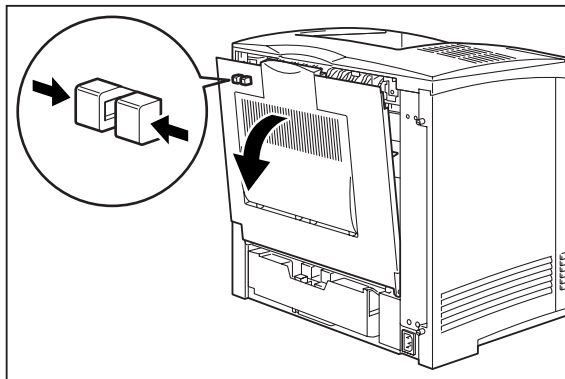

4. Pull the duplex unit toward you while sliding the left and right tabs inward, then grasp the recessed areas on the sides of the duplex unit and remove it from the printer.

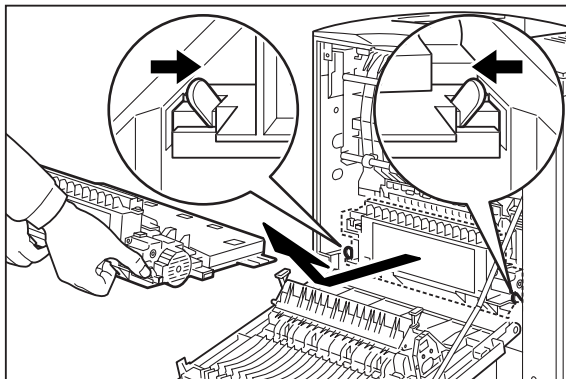

- Close the rear cover.

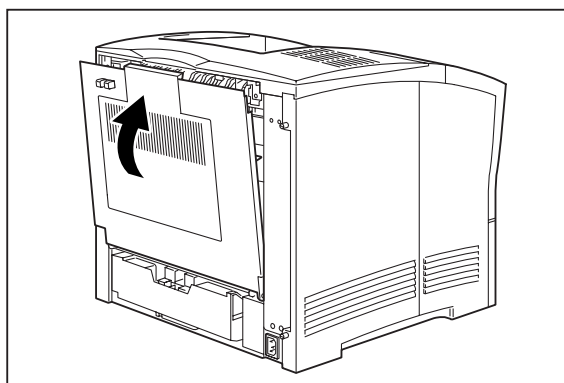



# Chapter 7

## Using the 550 Sheet Feeder

### In this Chapter . . .

- “About the 550 Sheet Feeder” on page 7-2
- “Installing the 550 Sheet Paper Feeders” on page 7-3
- “Testing the 550 Sheet Feeder” on page 7-11
- “Selecting Print Media” on page 7-11
- “Loading Print Media” on page 7-12
- “Solving 550 Sheet Feeder Problems” on page 7-16
- “Maintaining the 550 Sheet Feeder” on page 7-21
- “Moving the 550 Sheet Feeder” on page 7-29

## About this Chapter

This chapter provides all of the information necessary to install, use, and maintain the 550 sheet paper feeder option, including procedures for cleaning the feeder and removing paper jams.

## About the 550 Sheet Feeder

The 550 sheet feeder is an optional single tray paper feeder that attaches under the printer. The feeder holds a universal paper tray that accommodates a variety of print media and holds a maximum of 550 sheets of standard weight paper. The printer supplies all of the operating power that is needed by the feeder, and motors and circuit boards internal to the feeder provide the feeder with drive and operational logic.

At the start of a print run the feeder motor switches on and begins to feed a sheet of paper out of a selected tray. Rubber rollers drive the sheet out of the tray, through the feeder, and into the printer. Sensors monitor the progress of the paper as it travels through the feeder.

The 550 sheet feeder can be installed in the following configurations:

- Printer and one 550 sheet feeder
- Printer and two 550 sheet feeders

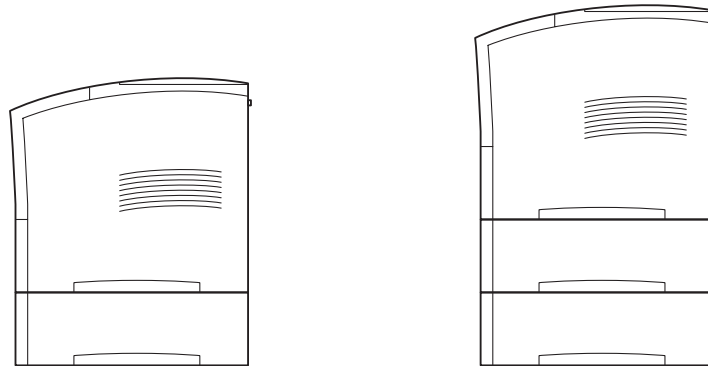

## Major Components of the 550 Sheet Feeder

The following illustration shows the major components of the 550 sheet feeder:

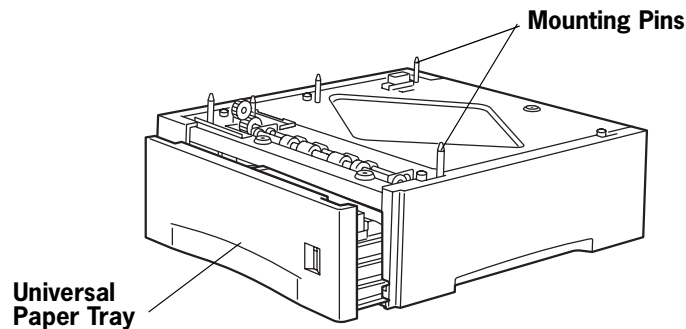

## Installing the 550 Sheet Paper Feeders

Before installing the paper feeder(s), verify that you have received the following items in the paper feeder shipping box:

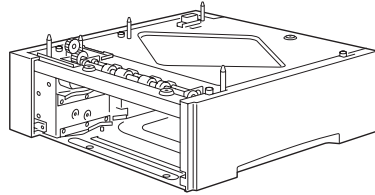

550 Sheet Paper Feeder

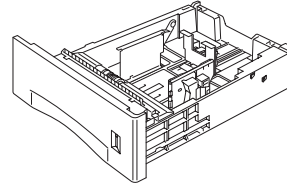

Universal Paper Tray



3 Thumbscrews

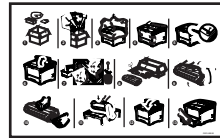

Installation Sheet

### Installing One Paper Feeder

Use the following procedure to install one paper feeder:



**WARNING:** Before installing any options, turn the printer off by pressing [ O ] on the power switch on the right side of the unit and disconnect the power cord from the AC outlet. These precautions are necessary to avoid the risk of electric shock.

1. Remove the 550 sheet paper feeder from its packaging and remove any cardboard inserts and packing tape. Locate and set aside the small plastic bag containing three thumbscrews.
2. Place the paper feeder on a sturdy, level surface.

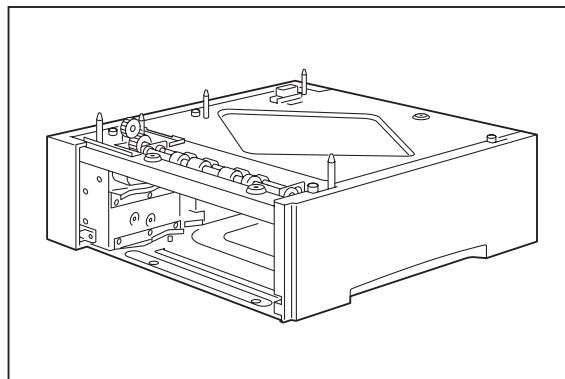

**NOTE:** Do not move the printer once the paper feeder is installed.

3. Turn the printer off by pressing [ O ] on the power switch on the left front of the unit.

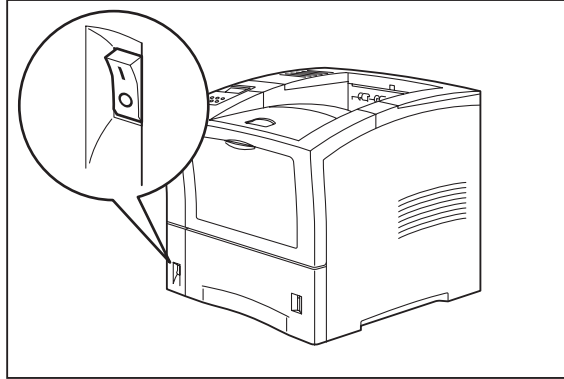

---

**NOTE:** Installing the paper feeder while the printer is on may damage the printer or paper feeder.

---

4. Disconnect the power cord from the AC outlet and from the printer.

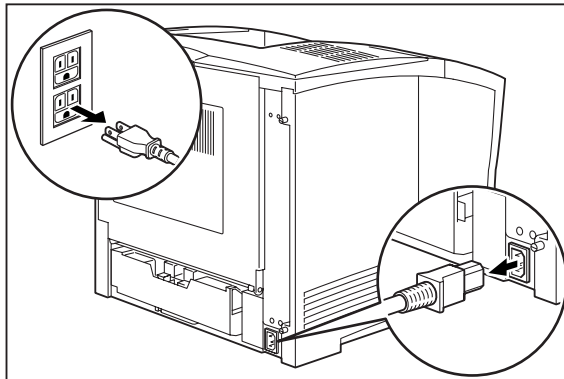

5. Close the multi bypass feeder, and remove any printed sheets from the paper output tray.

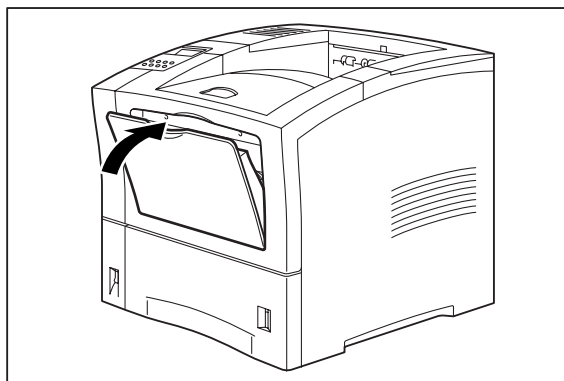

6. Remove the main cover from the printer.

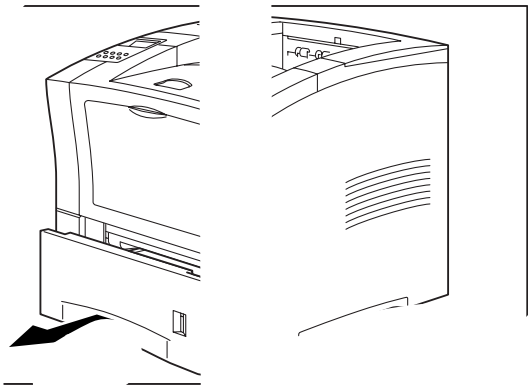

7. Align the holes on the bottom of the printer onto the bottom of the paper feeder and lower the paper feeder into the printer.

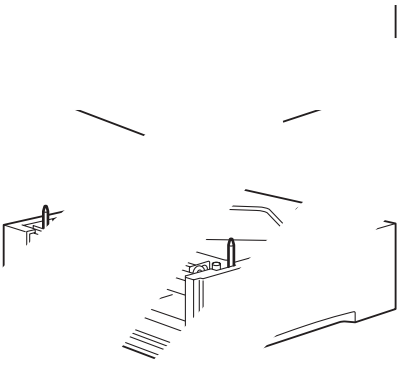

**NOTE**

8. Line up the three screws on the base of the paper feeder with the three holes on the base of the printer and tighten them.

9. Load paper into the paper tray.

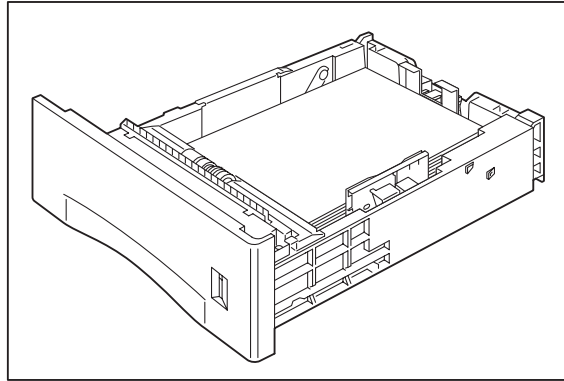

10. Insert the feeder paper tray and the main paper tray all the way into the paper feeder, making sure each is properly seated inside the printer.

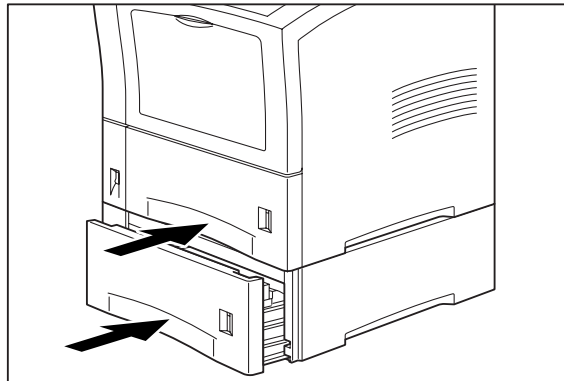

11. Insert the plug of the power cord into the AC outlet, and turn the printer on by pressing [ I ] on the power switch on the left front of the printer.

---

**NOTE:** If an error message appears on the control panel display, see **Chapter 5: Troubleshooting**.

---

### Installing Two Paper Feeders

Use the following procedure to install two paper feeders:

1. Remove the paper feeders from their packaging and remove any packing tape or cardboard inserts. Set aside the small plastic bags, each containing three thumbscrews.

2. Place one paper feeder on a sturdy, level surface.

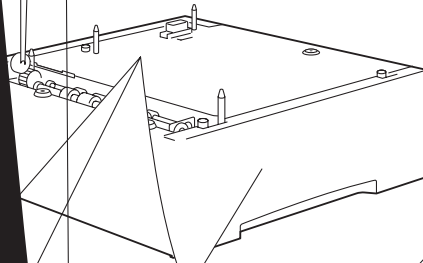

**NOTE:** Do not move the printer until the paper feeders are installed.

3. Align the three holes on the top of the feeder with the three holes on the printer, and place the upper cover on the feeder.

4. Push the paper feeder into the two holes on the base of the printer until tight.

- Turn the printer off by pressing [ O ] on the power switch on the left front of the printer.

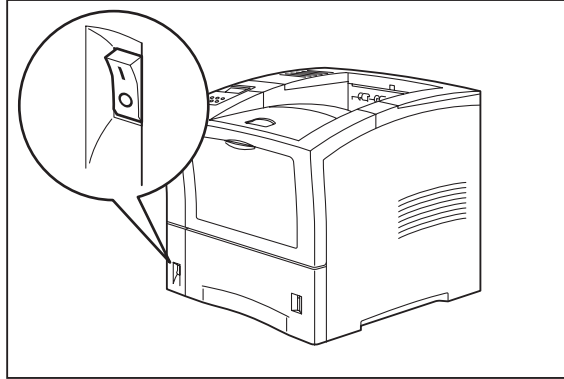

6. Disconnect the power cord from the AC outlet and from the printer.

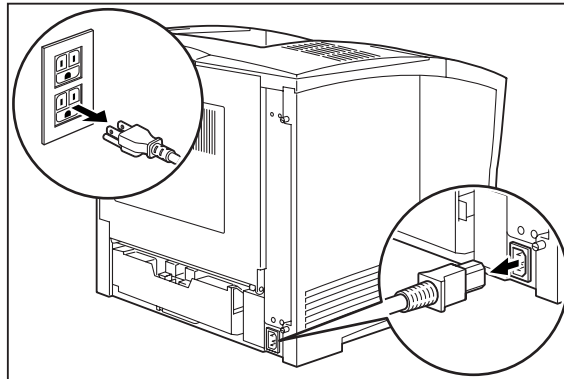

---

**NOTE:** Installing the paper feeder while the printer is on may damage the printer or the paper feeder.

---

7. Close the multi bypass feeder, and remove any printed sheets from the output paper tray.

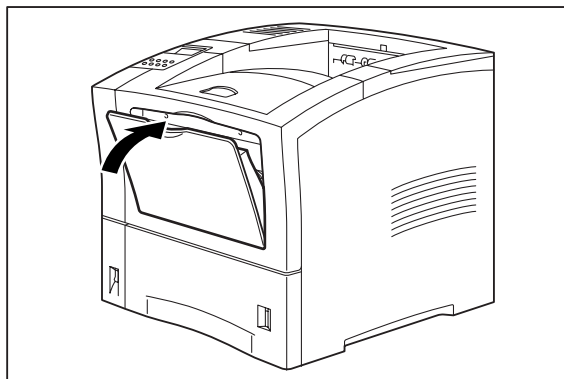



8. Remove the main paper tray from the printer.

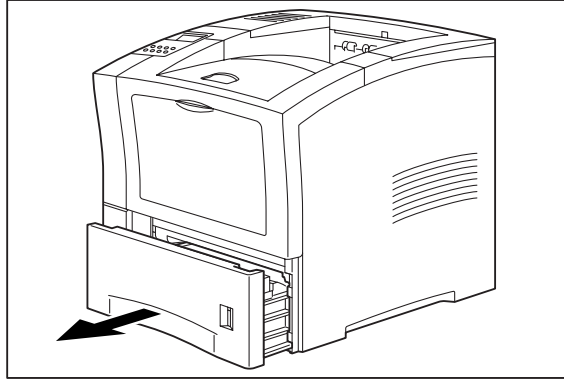

9. Lift the printer and lower it onto the two stacked paper feeders, aligning the pegs on the upper paper feeder with the holes on the bottom of the printer.

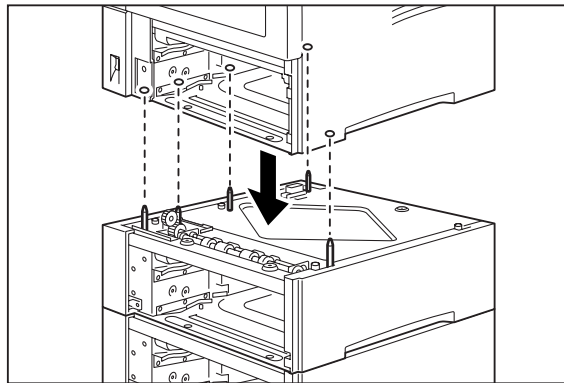

---

**NOTE:** Be sure to lower the printer gently. Components inside the printer may be damaged by lowering it quickly.

---

10. Insert the three thumbscrews supplied with the paper feeder into the holes on the base of the printer.

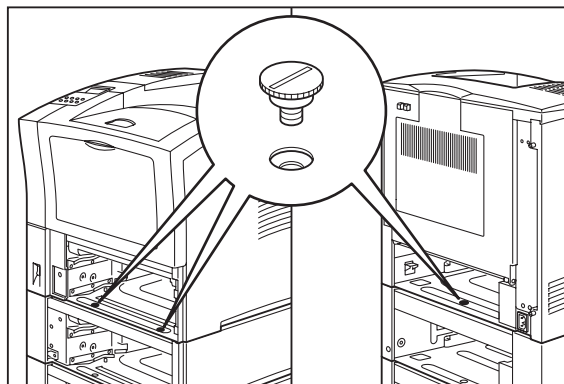

11. Load paper into the paper trays for both paper feeders.

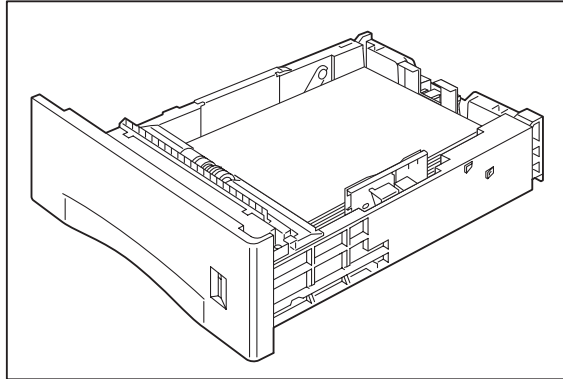

12. Insert the paper trays all the way into the paper feeders, making sure each tray is properly seated.

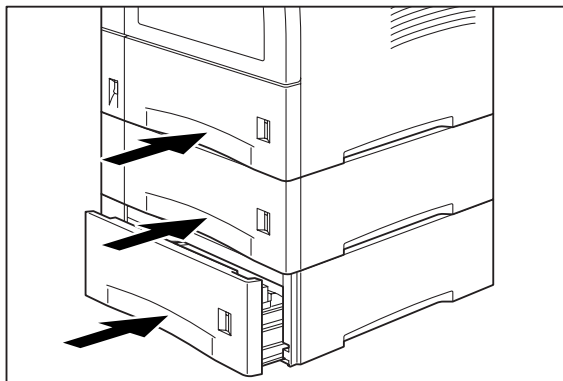

13. Connect the AC power cord to the printer and the AC wall outlet.
14. Turn the printer on by pressing [ I ] on the power switch on the left front of the printer.

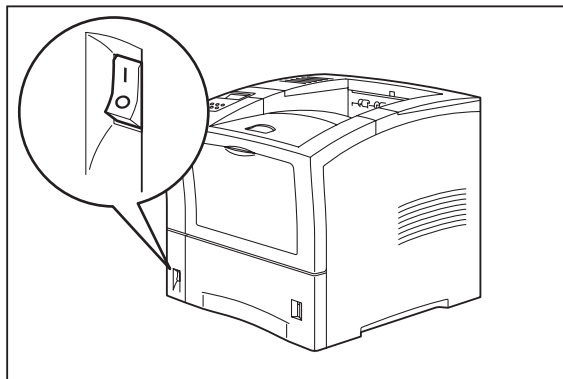

---

**NOTE:** If an error message appears on the control panel display, see the Chapter titled “Error Messages” in the User Manual.

---

## Testing the 550 Sheet Feeder

After installing the 550 sheet paper feeder, use the following test procedure to verify that the feeder is operating correctly.

1. Turn the printer on by pressing the [ I ] on the power switch on the right side of the printer.
2. Once the printer has warmed up and displays the “Ready” message on the control panel display, use any software application to print a few sheets from each of the feeder trays.
3. If the feeder does not feed paper or if the control panel displays an error message, refer to “Solving 0 Sheet Feeder Problems” on page 16.

## Selecting Print Media

Your printer can print on a variety of media, including plain paper, labels, transparencies, and envelopes. Always use print media that meet the guidelines for use with this printer. Print media that is not recommended for use with this printer may cause frequent paper jams or poor print quality.

### Paper and Print Media To Avoid

Do not use paper or print media that has any of the following characteristics:

- Does not meet the paper and media size and weight specifications for this printer
- Is not labeled for use with xerographioasah(o)-a4 1 Tf0 0 0 scn1.5055 0 TD-0s(a)18.ex-7.3phaaster

- Store reams of paper in an area away from both direct sunlight and high humidity
- Open sealed reams only when you are ready to load the paper into the paper tray, and always close and seal partial reams of paper.
- Do not stack partial reams of paper

### Print Media Weight, Type, and Size

The 550 sheet feeder has paper guides that allow you to accommodate paper with the following dimensions:

- Paper Width: 98.4mm minimum to 215.9mm maximum
- Paper Length: 148.5mm minimum to 355.6mm maximum

The following table defines print media that you can use in the 550 sheet feeder paper tray, and also indicates the feed orientation—long edge feed (LEF) or short edge feed (SEF). If you have concerns about a specific brand or type of media, try samples of the media to determine if the resulting printer performance and print quality meet your expectations.

Paper Source	Weight	Paper Type and Feed Direction	Paper Sizes Accommodated
<b>Universal A4/Letter/Ledger Paper Tray</b> (main tray and optional 550 sheet A4/Letter/Ledger paper feeder)	55-134 kg 16 to 24 lbs. 60 to 216g/m <sup>2</sup>	A4 SEF	297 x 210mm 11.7 x 8.27 inches
		Letter SEF	279.4 x 215.9mm 11 x 8.5 inches
		Legal 13" SEF	330.2 x 215.9mm 13 x 8.5 inches
		Legal 14" SEF	355.6 x 215.9mm 14 x 8.5 inches
		Executive SEF	266.7 x 184.5mm 10.5 x 7.26 inches
		B5 SEF	257 x 182mm 10.1 x 7.2 inches
		A5 SEF	210 x 149mm 8.27 x 5.9 inches

## Loading Print Media

### Loading the A4/Letter/Legal Paper Tray

The 550-sheet universal paper tray has two width guides that are located on the sides of the tray, and one length guide that is located near the center of the tray. These guides allow you to adjust the size of the area that holds paper.

---

**NOTE:** The following procedure shows you how to load paper into the main paper tray. To load paper into the optional 550 sheet paper feeder, simply complete the procedure using the 550 sheet paper tray and feeder rather than the main paper tray.

---

Use the following procedure to load paper into the 550 sheet A4/letter/legal paper tray:

1. Place the paper tray on a level surface.

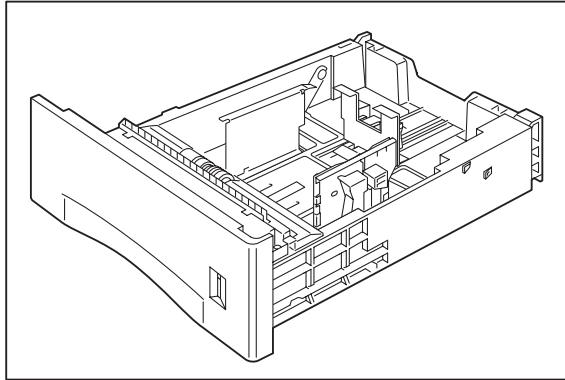

2. Squeeze the length guide, lift it up, and slide it to the rear of the tray.

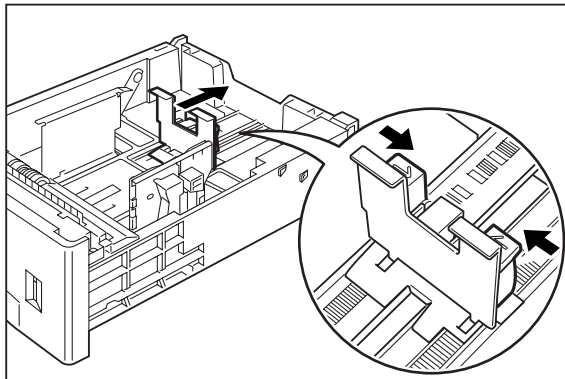

3. If the paper you are using is longer than A4 (297 cm), press the square green button on the bottom of the paper tray to release the rear of the tray, and pull the tray out to extend it.

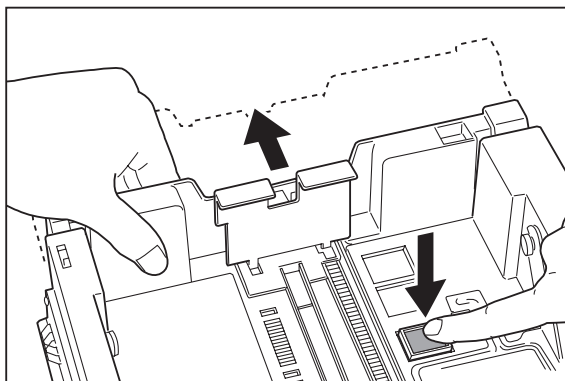

4. Squeeze the right width guide, lift it up, and slide the guides to the sides of the tray.

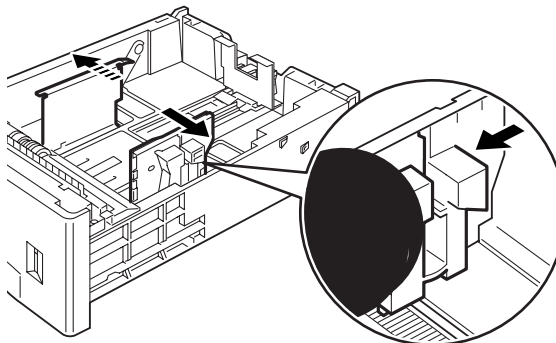

- Verify that the plate has dropped down into the base of the paper tray. If the tray is locked in the up position, pull the lever near the front of the tray to release the plate, or push the paper tray all the way into the printer and then remove it.

6. Align the edges of the paper and place it in the center of the paper tray with the print side down.

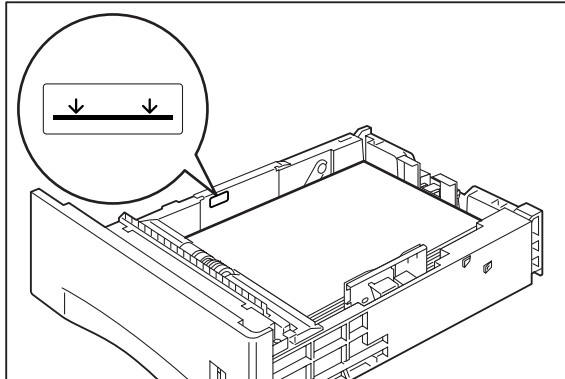

---

**NOTE:** To avoid paper jams and other paper transportation problems, make sure the length and width guides are adjusted to match the paper size and are locked firmly into place

---

7. Squeeze the right width guide, lift it up, and adjust the guides to match the paper width.

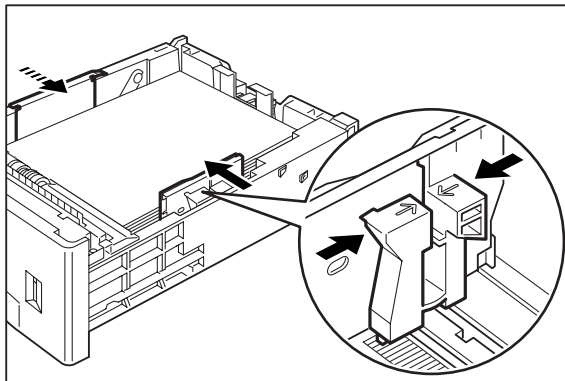

8. Squeeze the length guide, lift it up, and adjust the guide to match the paper length.

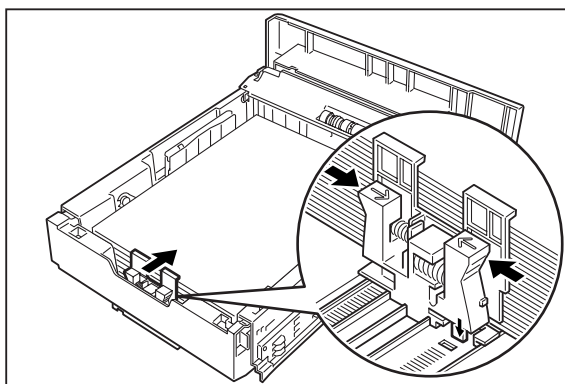

9. Grasp the paper tray with both hands and insert it into the paper tray well on the printer.

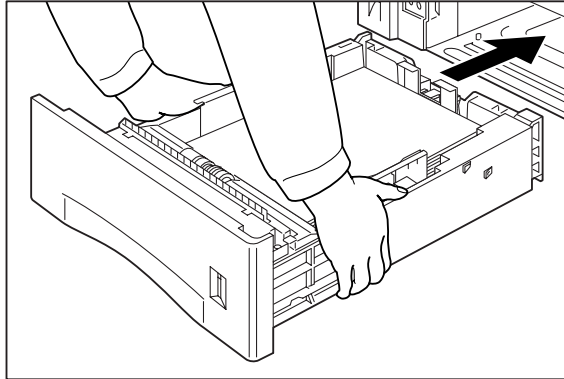

10. Push the paper tray completely into the printer, making sure the tray is properly seated..

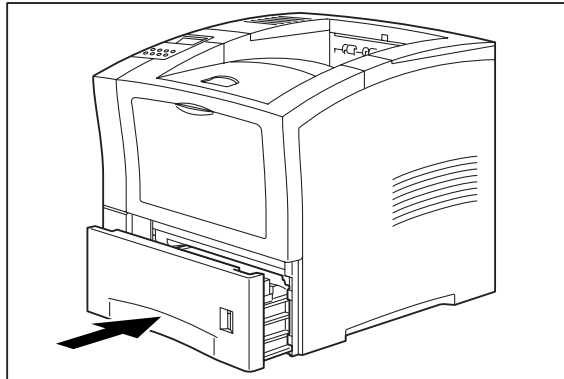

11. Use the paper level indicator on the front right of the printer to determine when the paper supply is low.

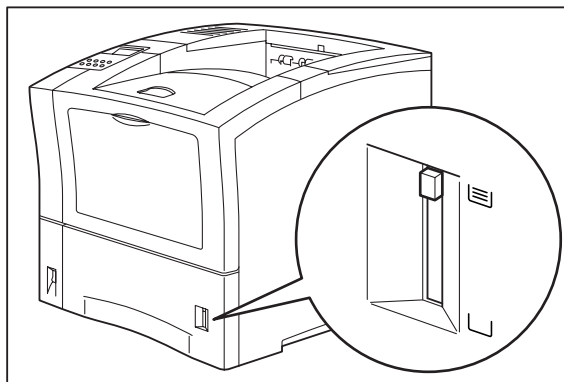

## Solving 550 Sheet Feeder Problems

When there is a problem with the 550 sheet feeder, the printer control panel displays an error code and error message. Most paper feeder error codes indicate routine status conditions such as a paper tray running out of paper or a paper jam in a specific area of the paper feeder. Some error codes indicate much more serious problems that may require the help of a service technician.



- If the paper feeder is inoperative after installation, refer to “**Installation Problems**” on page 7-17 and complete the recommended procedure.
- If the printer control panel displays an error message or an error code, refer to “**Interpreting Paper Feeder Error Messages**” on page 7-17.
- If you have a paper feeder problem but the printer control panel does not display an error message or error code, refer to “**Correcting Miscellaneous Paper Feeder Problems**” on page 7-19 and follow the directions for correcting that problem.

### Interpreting Paper Feeder Error Messages

The printer control panel displays error messages when there is a problem with the printer or any of the optional paper-handling components. The following table lists all of the error messages associated with the 550 sheet paper feeder, the possible cause of the error, and the action to take to correct the problem. If the control panel shows an error message that concerns another part of the printer, refer to **Chapter : Troubleshooting** for a complete list of all warning and error messages.

<b>Error or Warning Message Line 1</b>	<b>Error or Warning Message Line 2</b>	<b>Possible Cause</b>	<b>Action</b>
(Warning message, printer continues operating and line 1 shows printer status.)	Paper Out Tray 2 (applies to first paper feeder if installed)	There is no paper in tray 2.	Add paper to the tray.
	Paper Out Tray 3 (applies to second paper feeder if installed)	There is no paper in tray 3.	Add paper to the tray.
<b>TRAY 2 MISSING</b> (applies to first paper feeder if installed)	Insert Tray	Tray 2 is not installed.	Install the tray.
<b>TRAY 3 MISSING</b> (applies to second paper feeder if installed)	Insert Tray	Tray 3 is not installed.	Install the tray.
<b>E2-1 JAM MISFEED</b>	Remove paper	There is a misfeed jam near the source paper tray.	Remove the jammed paper from the source tray.
<b>LOAD PAPER TRAY2</b> (applies to first paper feeder if installed)	Paper Size/ Paper Type	Tray 2 is empty.	Load paper into the tray.
<b>LOAD PAPER TRAY3</b> (applies to second paper feeder if installed)	Paper Size/ Paper Type	Tray 3 is empty.	Load paper into the tray.
<b>OPTION TRAY FAIL</b> Call Service			Turn printer off then on. If problem persists, call your service provider.

### Installation Problems

Simple oversights during installation may cause problems when you first use the paper feeder. If the paper feeder is inoperative after you have installed it, use the following procedure to check several possible causes.

1. Turn the printer off by pressing the [ O ] on the power switch on the right side of the printer.
2. Remove and then reinstall the feeder.
3. If the feeder is still inoperative after reinstallation, remove it from the printer so you can run tests on the printer alone.
4. Print a few sheets of paper through the main paper tray or the front tray to make sure the printer is still operational.
  - If the printer is operational when the feeder is not attached, contact either your sales representative or a service technician and report your problem.
  - If the printer is not operational when the feeder is not attached, refer to **Chapter 4: Troubleshooting**. After correcting the printer problem, return to **Chapter 7: Using the 550 Sheet Feeder** to reinstall the feeder.

### Clearing an E2 Paper Jam

If an E2 error code precedes the error message on the first line of the control panel display, paper has jammed somewhere between the paper source feed area and the toner cartridge. If you are using the optional feeder as the current paper source, use the following procedure to clear a paper jam in this location:

1. Remove any printed pages from the output tray.
2. Remove the paper tray from any optional feeders and from the printer, and inspect the inside of the paper tray well, removing any jammed paper.

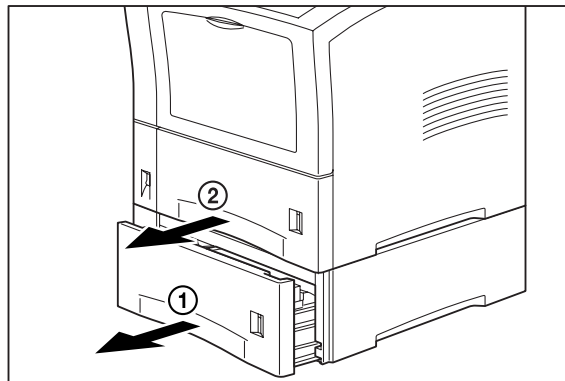

3. Remove any wrinkled or creased paper from the paper tray.

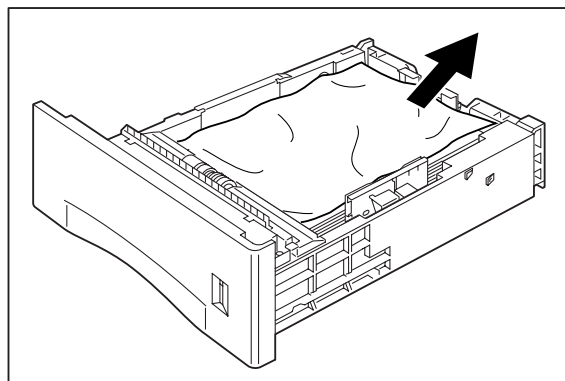

4. Push the paper trays back into the printer and optional feeders.

### Correcting Miscellaneous Paper Feeder Problems

Some paper feeder problems may not cause an error message and may not interfere with the operation of the printer. If you are experiencing one of the problems listed below and there is no error message shown on the control panel display, refer to the procedures in the following sections to check the possible causes of the specific problem.

- Inoperative paper feeder
- Erratic operation
- Unusual noise

#### *Inoperative 550 Sheet Paper Feeder*

The following characteristics define this feeder problem:

- The feeder appears to be inoperative.
- When attempting to print from the feeder, the feeder does not respond and does not feed paper.
- The control panel does not display an error code.

The following procedure guides you through multiple actions that may solve this feeder problem. Proceed one step at a time until the problem is solved—you may not need to complete the entire procedure. If one of the steps in this procedure corrects the problem but the identical problem returns in less than 30 prints, call for service.

1. Open and then firmly close all of the printer and feeder doors and covers.

Interlock switches monitor the position of printer doors and covers. When a door is closed, the interlock switch is activated and the feeder can operate. When a door is open, the interlock switch is not activated and the feeder cannot operate. If a door is not firmly closed, the interlock switch may not be fully activated—resulting in an inoperative feeder.

2. Test the printer by printing a few sheets from the main tray.

If you cannot print a sheet of paper from the main tray and the printer does not display an error code, go to “Inoperative Printer” on page 5-3. If you can print a sheet of paper fr-251.37.3()-22906 T

- 1.

4. If the 550 sheet feeder is correctly set as an installed option, reload the printer driver software.  
The printer driver software running on the host computer may be damaged. Reinstalling the software is an easy and inexpensive way to isolate or eliminate the problem. Refer to the **DRIVERS** folder on the Electronic Library CD-ROM for detailed instructions on installing the driver.
  - Call your service technician.  
This problem may be caused by a malfunctioning or broken component that requires service.

#### *Feeder Operates Erratically*

The following characteristics define this feeder problem:

- The feeder does not function correctly.
- The control panel does not display an error code.

The following procedure guides you through multiple actions that may solve this feeder problem. Proceed one step at a time until the problem is solved—you may not need to complete the entire procedure. If one of the steps in this procedure corrects the problem but the identical problem returns in less than 50 prints, call for service.

1. Open and then firmly close all of the printer and feeder doors and covers.  
Interlock switches monitor the position of printer doors and covers. When a door is closed, the interlock switch is activated and the feeder can operate. When a door is open, the interlock switch is not activated and the feeder cannot operate. If a door is not firmly closed, the interlock switch can bounce between being activated and being not activated - confusing the system and causing erratic operation.
2. Reinstall the printer driver software.  
The printer driver software running on the host computer may be damaged. Reinstalling the software is an easy and inexpensive way to isolate or eliminate the problem. Refer to the **DRIVERS** folder on the Electronic Library CD-ROM for detailed instructions on installing the drivers.
3. Call your service technician.  
This problem may be caused by a malfunctioning or broken component that requires service.

#### *Feeder Makes Unusual Noises*

The following characteristics define this feeder problem:

- The feeder makes unusual noises or makes more noise than usual either while idle or while printing.
- The feeder feeds paper without a problem.
- The control panel does not display an error code.

The following procedure guides you through multiple actions that may solve this feeder problem. Proceed one step at a time until the problem is solved—you may not need to complete the entire procedure. If one of the steps in this procedure corrects the problem but the identical problem returns in less than 50 prints, call for service.

1. Remove the paper trays and inspect the inside of the feeder for jammed paper or obviously broken components.

Broken components or scraps of paper lodged inside the feeder may be brushing against moving parts and causing the noise.

2. Call your service technician.

This problem may be caused by a malfunctioning or broken component that requires service.

## Maintaining the 550 Sheet Feeder

The 550 sheet feeder requires very little maintenance; however, normal daily use requires you to perform some routine maintenance including replacing parts of the feeder.

### Replacing Feed Roll, Nudger Roll, and Retard Roll

Rubber feed rolls drive sheets of paper out of the feeder paper trays into the printer. These feed rolls wear with normal use and eventually become coated with paper dust and must be replaced. Frequent feed jams in the front tray or main tray indicate that the feed rolls need to be replaced.

---

**NOTE:** The following procedure illustrates the process of replacing the feed roll, retard roll, and nudger roll for the main paper tray. To replace the rolls for a paper feeder, use the same procedure but remove the paper tray of the paper feeder and replace the feed rolls in the paper tray well of that feeder.

---

1. Turn the printer off by pressing the [ O ] on the power switch on the right side of the printer, and disconnect the AC power cord from the wall outlet.

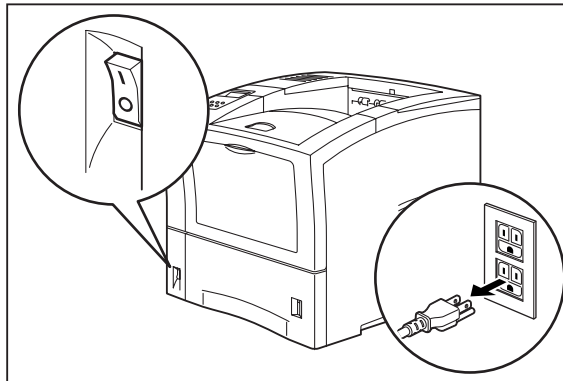



- Push the new feed roll and nudger roll onto their shafts until the retaining tabs click into place. Make sure the tabs are toward the right side of the printer.

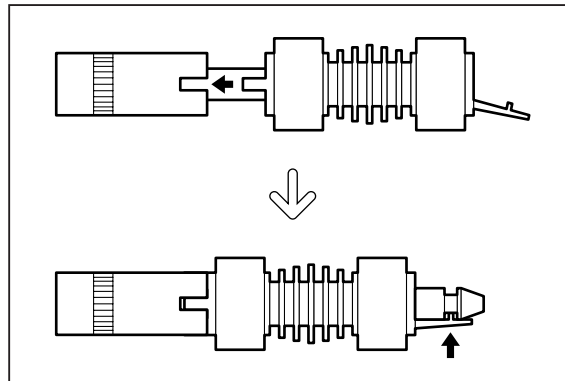
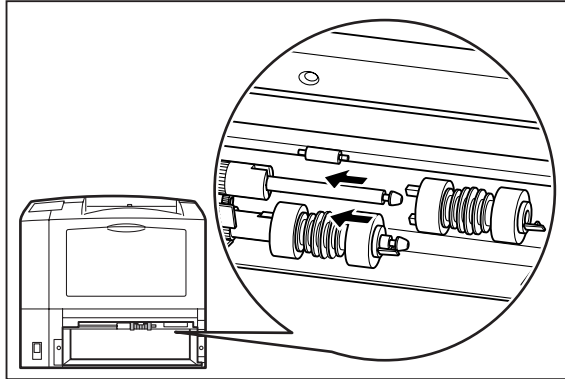

6. Release the metal stopper plate inside the printer so it returns to its normal position.

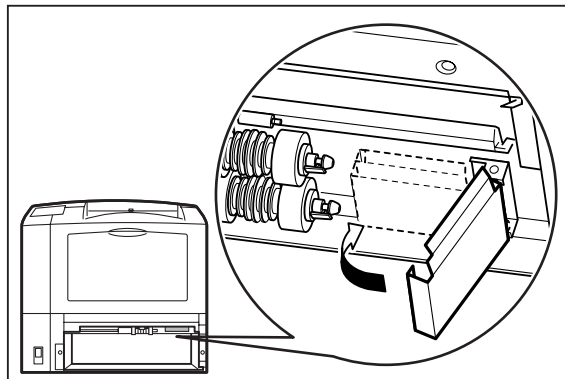

7. Press the locks on the left and right of the retard roll inside the paper tray. Lift the lever to open the retard roll cover.

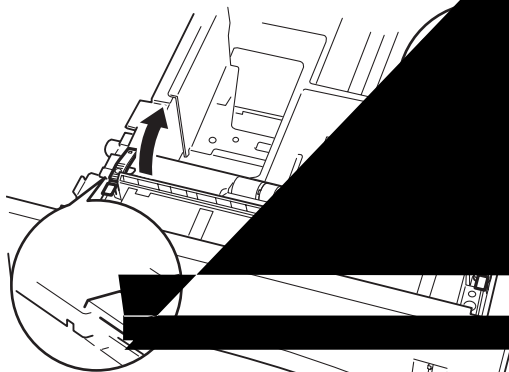

8. Unclip the retaining tab on the retard roll and remove it from the shaft.

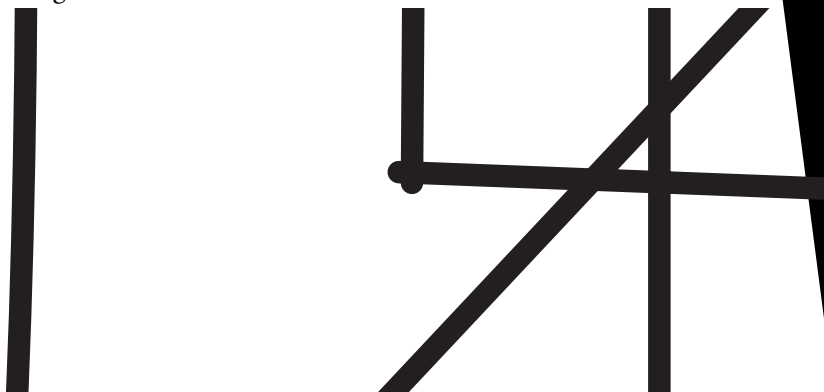



9. Push the new retard roll onto the shaft until the retaining tab clicks into place. Make sure the retaining tab is toward the right side of the printer.

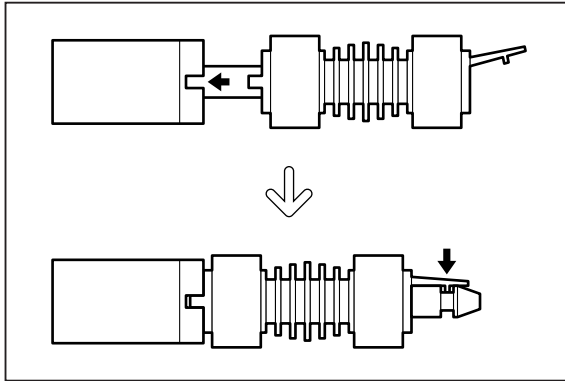
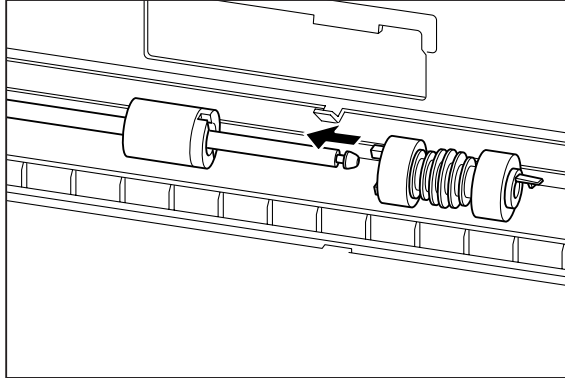

10. Close the retard roll cover.



11. Grasp the paper tray with both hands and insert it into the paper tray well on the printer.

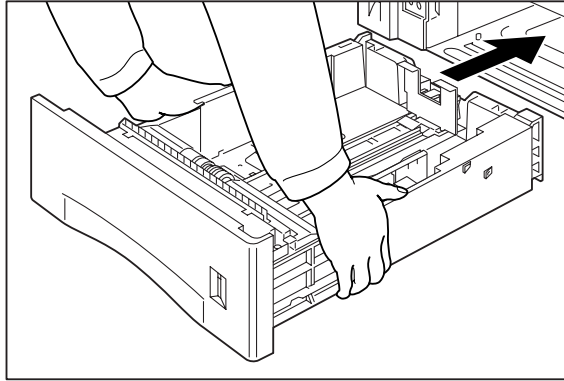

12. Push the paper tray all the way into the printer, making sure the tray is properly seated.

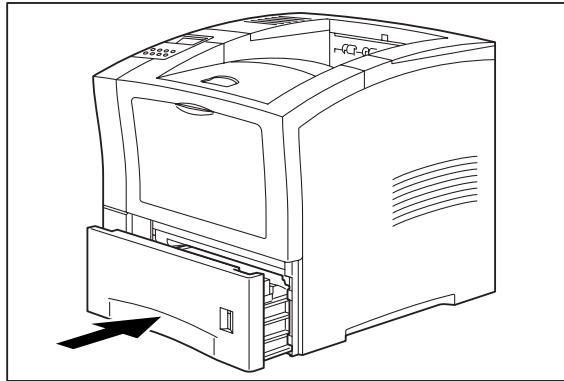

## Removing the 550 Sheet Feeder

Use the following procedure to remove the 550 sheet feeder:

1. Turn the printer off by pressing the [O] on the power switch on the front left of the printer.

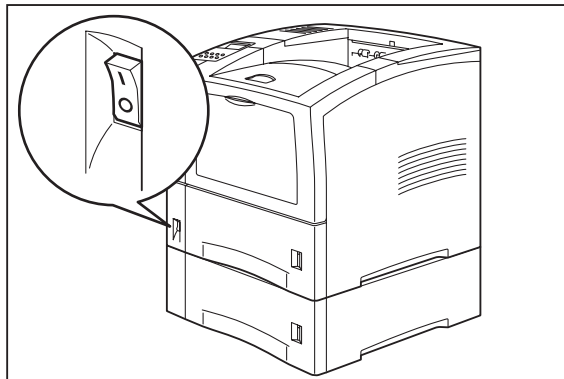

2. Disconnect the power cord from the AC outlet.

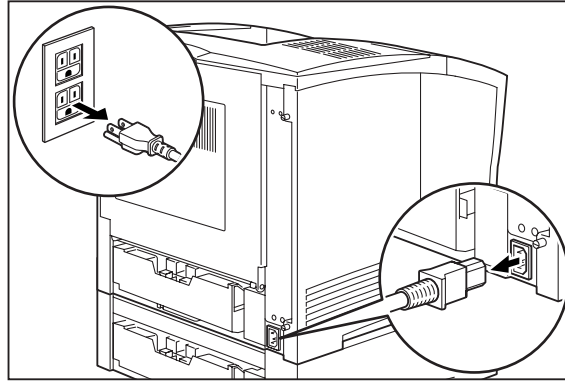

**CAUTION:** Removing or installing the paper feeder while the printer is on may damage the printer or paper feeder.

3. Close the front tray and remove any printed sheets from the paper output tray.

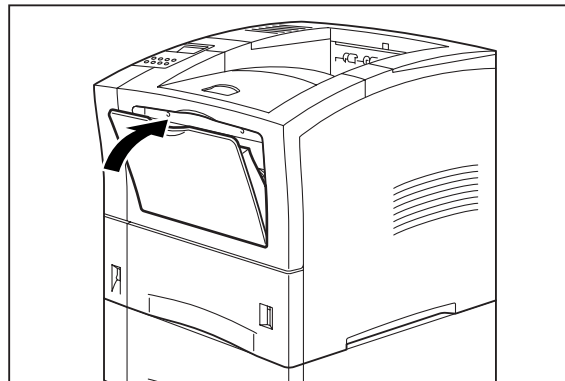

4. Remove the paper trays from the 550 sheet feeder and the printer.

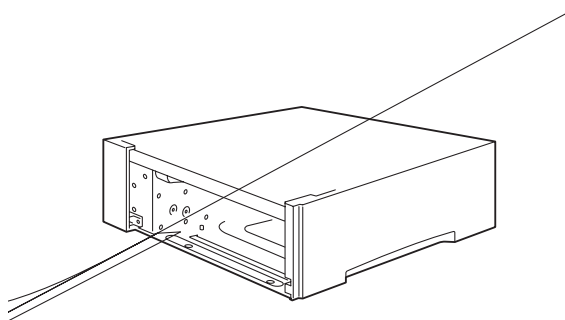

- Remove the three screws that secure the printer to the paper feeder.

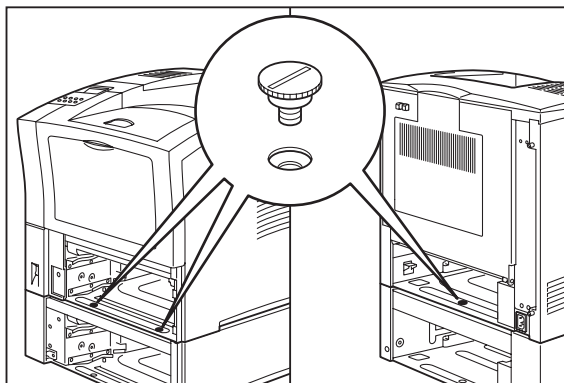

- 6. Lift the printer to remove it from the feeder.

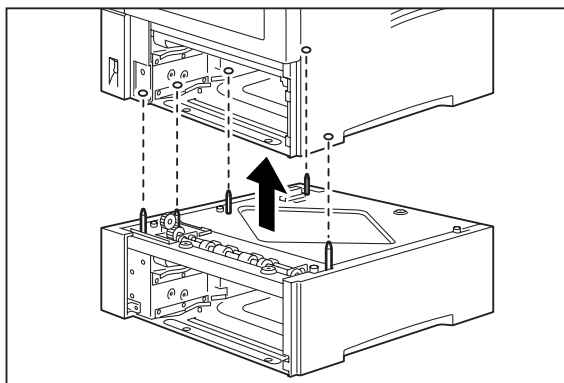

## Moving the 550 Sheet Feeder

When moving the printer a short distance, you may leave the 550 sheet paper feeder attached. However, when moving the printer a long distance, please remove the 550-sheet paper feeder to avoid damaging either the printer or the feeder.

### Moving the Printer and 550 Sheet Feeder a Short Distance

Use the following procedure to move the printer and 550 sheet feeder a short distance:

1. Turn the printer off by pressing the [ O ] on the power switch on the back of the printer.
2. Unplug the AC power cord from the AC wall outlet.
3. Disconnect the printer from the host computer.
4. Wait 30 minutes for the printer to cool.
  - . Remove the toner cartridge and cover it with an opaque plastic sheet.
6. With the help of another person, carefully lift the printer and attached 550 sheet feeder and move them to the new location.
7. Once the printer is in the new location, refer to the **Installation Guide** included in the original printer packaging to reinstall the printer.

### Moving the Printer and 550 Sheet Feeder a Long Distance

Use the following procedure to move the printer and 550 sheet feeder a long distance:

1. Turn the printer off by pressing the [ O ] on the power switch on the right side of the printer.
2. Unplug the AC power cord from the wall outlet and from the back of the printer.
3. Disconnect the printer from the host computer.
4. Remove the paper from all of the paper trays.
  - . Wait 30 minutes for the printer to cool.
6. Remove the main paper tray.
7. Reach inside the open top tray and locate the two thumbscrews that are at the front left and front right of the feeder.
8. Unscrew the two thumbscrews to release the feeder from the printer.
9. Lift the printer off of the 550 sheet feeder and place it on the floor or on a table.
10. Repack the feeder in the original shipping box.
11. Remove the toner cartridge and place it in an opaque plastic bag, then seal the bag with tape and place it in a sturdy box.
12. Repack the printer, paper trays, AC power cord and toner cartridge into the original shipping box or boxes.
13. Once the feeder is in the new location, refer to “Installing the 550 Sheet Paper Feeders” on page 3 to reinstall the paper feeder(s).





# Chapter 8

## Using the Envelope Feeder

- “About this Chapter” on page 8-2
- “About the Envelope Feeder” on page 8-2
- “Installing the Envelope Feeder” on page 8-2
- “Testing the Envelope Feeder” on page 8-4
- “Selecting Print Media” on page 8-4
- “Loading the Envelope Feeder” on page 8-6
- “Solving Envelope Feeder Problems” on page 8-7
- “Maintaining the Envelope Feeder” on page 8-13

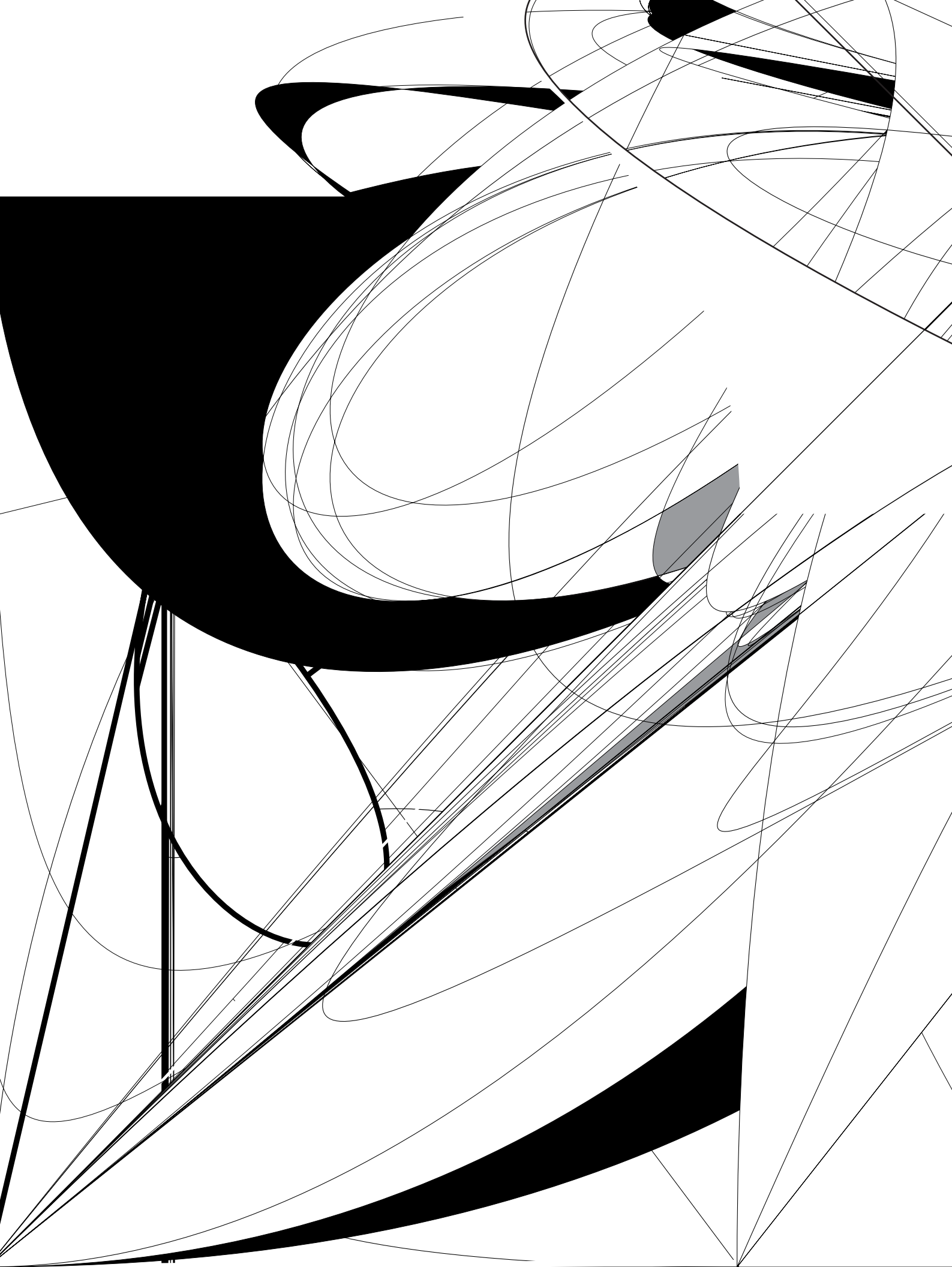



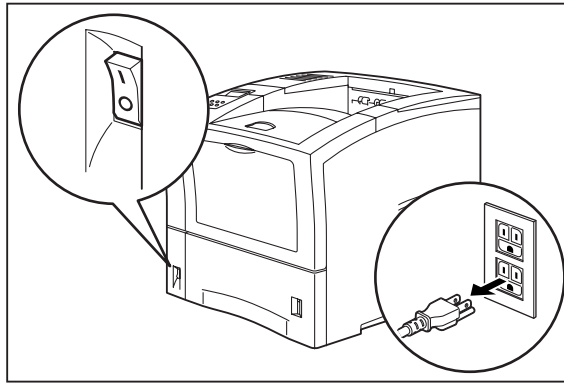

**NOTE:** Installing the envelope feeder while the printer is on may damage the printer or the envelope feeder.

2. Remove the envelope feeder from its packaging and place it on a level surface. Remove any cardboard inserts and packing tape.

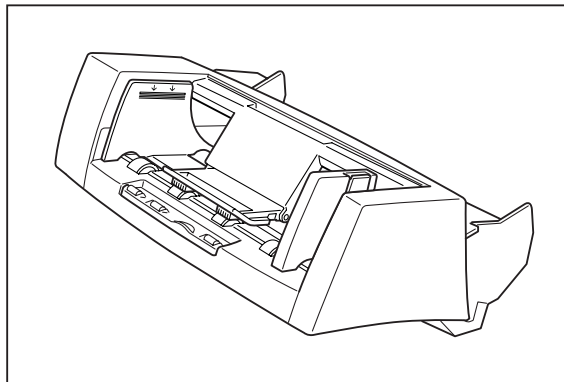

3. Pull on the recessed area on the front of the printer to open the front tray.

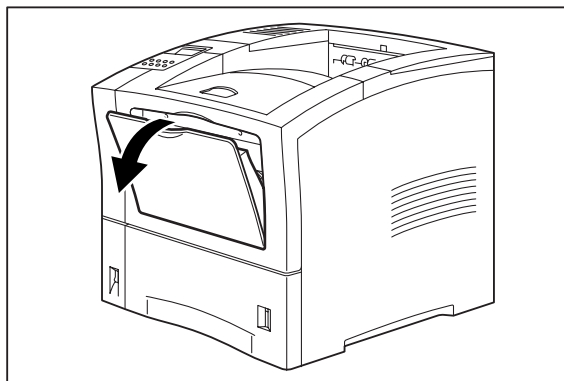

4. Remove the gear cover on the left side of the inside of the printer and store it in a safe place.

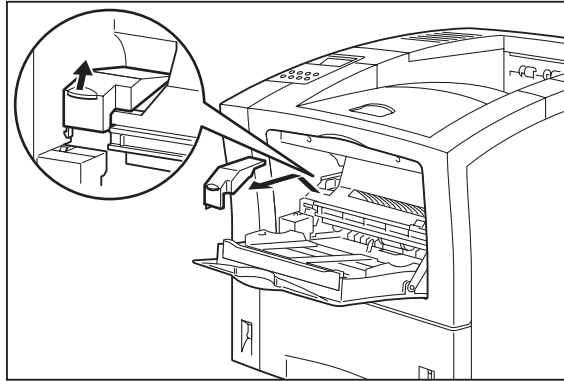

- Push the envelope feeder all the way into the printer until it stops, making sure it is seated firmly inside the printer.

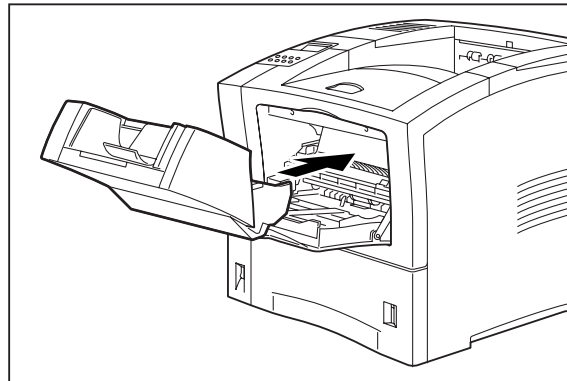

## Testing the Envelope Feeder

After installing the envelope feeder, use the following test procedure to verify that the feeder is operating correctly.

1. Turn the printer on by pressing the [ I ] on the power switch on the right side of the printer.
2. Once the printer has warmed up and displays the “Ready” message on the control panel display, use any software application to print a few sheets from the envelope feeder.
3. If the feeder does not feed paper or if the control panel displays an error message, refer to “Solving Envelope Feeder Problems” on page 7.

## Selecting Print Media

Your printer can print on a variety of media, including plain paper, labels, transparencies, and envelopes. Always use print media that meet the guidelines for use with this printer. Print media that is not recommended for use with this printer may cause frequent paper jams or poor print quality.

### Paper and Print Media To Avoid

Do not use paper or print media that has any of the following characteristics:

- Does not meet the paper and media size and weight specifications for this printer
- Is not labeled for use with xerographic printers or xerographic copiers
- Cannot withstand temperatures of up to 310°F/155°C
- Is in a sealed package that is obviously damaged or wet
- Is excessively wrinkled, curled, torn, or warped
- Is folded or creased
- Has either an extremely slick surface or an extremely textured surface
- Has an exposed adhesive surface
- Has paper pieces glued or taped to the media
- Has staples or paper clips attached
- Is categorized as thermal paper, coated paper, or carbon paper
- Is an envelope that is embossed, is made of extremely thick paper, or is padded
- Is an envelope that has metal clasps
- Is a sheet of labels that has the backing sheet exposed between individual labels

### Correct Paper Storage

It is important to store paper correctly prior to placing it in the printer, since improper storage can cause frequent paper jams and poor print quality. Use the following guidelines when storing paper for use in the printer:

- Store reams of paper on a flat surface, and always store them stacked horizontally.
- Store reams of paper in an area away from both direct sunlight and high humidity
- Open sealed reams only when you are ready to load the paper into the paper tray, and always close and seal partial reams of paper.
- Do not stack partial reams of paper

### Print Media Weight, Type, and Size

The following table defines print media that you can use in the envelope feeder. If you have concerns about a specific brand or type of media, try samples of the media to determine if the resulting printer performance and print quality meet your expectations.

Type of Envelope or Postcard		Maximum Capacity
Envelope	Commercial # 10	75
	Monarch	75
	DL	75
	C5	50



3. Lower the paper holder.

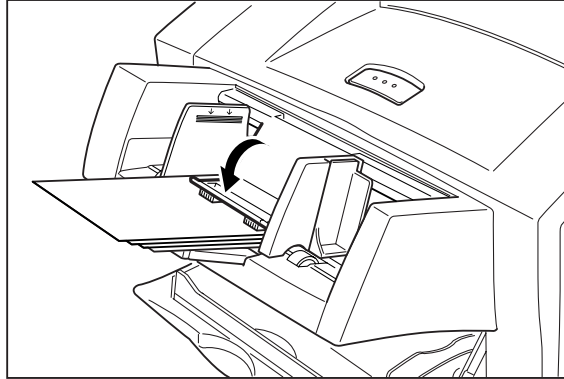

4. Adjust the paper guide to the size of the envelopes or postcards you are using.

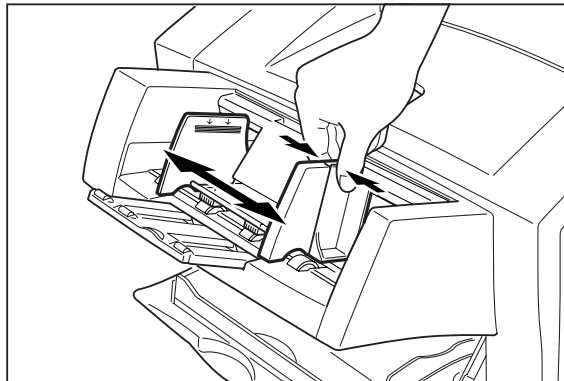

## Solving Envelope Feeder Problems

When there is a problem with the envelope feeder, the printer control panel displays an error code and error message. Most envelope feeder error codes indicate routine status conditions such as running out of paper or a paper jam. Some error codes indicate much more serious problems that may require the help of a service technician.

- If the printer control panel displays an error message or an error code, refer to “**Interpreting Envelope Feeder Error Messages**” on page 8-10.
- If you have an envelope feeder problem but the printer control panel does not display an error message or error code, refer to “**Correcting Miscellaneous Envelope Feeder Problems**” on page 8-10 and follow the directions for correcting that problem.

### Envelopes Become Creased when Printing

If envelopes are creased or wrinkled after printing, lift up the fuser release levers at the left and right side of the fuser unit, and try printing again. The printed image may appear thin using this method, but the envelopes will not be creased or wrinkled.

Use the following procedure to lift the fuser release levers:

1. If you are using the paper tray in its extended position, remove it from the printer.

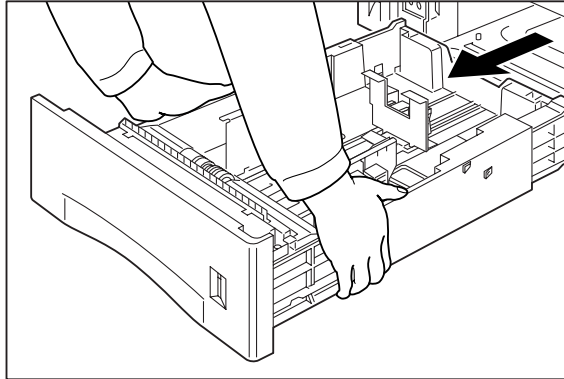

2. Squeeze the tabs on the rear cover and pull the cover toward you to open it.

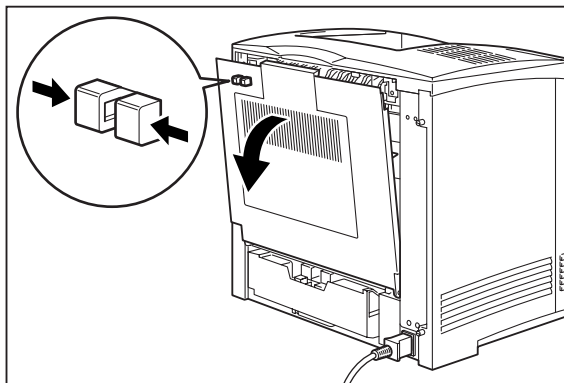

4. Lift up the fuser release levers at the left and right side of the fuser unit.

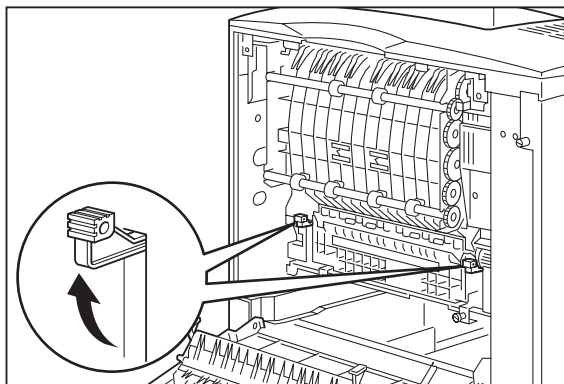



Insert the holes provided on the inside of the rear cover.

7. Close the rear cover.

### Interpreting Envelope Feeder Error Messages

The printer control panel displays error messages when there is a problem with the printer or any of the optional paper-handling components. The following table lists all of the error messages associated with the envelope feeder, the possible cause of the error, and the action to take to correct the problem. If the control panel shows an error message that concerns another part of the printer, refer to **Chapter 8: Troubleshooting** for a complete list of all warning and error messages.

Error or Warning Message Line 1	Error or Warning Message Line 2	Possible Cause	Action
<b>LOAD ENVELOPE</b>	Paper Size/Paper Type	The envelope tray is empty.	Load print media into the envelope tray.
<b>ENV UNIT FAILURE</b>	Check Feeder	The envelope feeder has been removed or has failed.	Check the envelope feeder to make sure it is properly installed. Turn the printer off, then on. If the problem reoccurs, contact your service provider.

### Correcting Miscellaneous Envelope Feeder Problems

Some envelope feeder problems may not cause an error message and may not interfere with the operation of the printer. If you are experiencing one of the problems listed below and there is no error message shown on the control panel display, refer to the procedures in the following sections to check the possible causes of the specific problem.

- Inoperative envelope feeder
- Erratic operation
- Unusual noise

#### *Inoperative Envelope Feeder*

The following characteristics define this feeder problem:

- The envelope feeder appears to be inoperative.
- When attempting to print from the envelope feeder, the envelope feeder does not respond and does not feed paper.
- The control panel does not display an error code.

The following procedure guides you through multiple actions that may solve this feeder problem. Proceed one step at a time until the problem is solved—you may not need to complete the entire procedure. If one of the steps in this procedure corrects the problem but the identical problem returns in less than 50 prints, call for service.

1. Open and then firmly close all of the printer and feeder doors and covers.

Interlock switches monitor the position of printer doors and covers. When a door is closed, the interlock switch is activated and the envelope feeder can operate. When a door is open, the interlock switch is not activated and the envelope feeder cannot operate. If a door is not firmly closed, the interlock switch may not be fully activated—resulting in an inoperative envelope feeder.

2. Test the printer by printing a few sheets from the main tray.



If you cannot print a sheet of paper from the main tray and the printer does not display an

The following procedure guides you through multiple actions that may solve this envelope feeder problem. Proceed one step at a time until the problem is solved—you may not need to complete the entire procedure. If one of the steps in this procedure corrects the problem but the identical problem returns in less than 50 prints, call for service.

1. Remove the paper trays and inspect the inside of the envelope feeder for jammed paper or obviously broken components.

Broken components or scraps of paper lodged inside the envelope feeder may be brushing against moving parts and causing the noise.

2. Call your service technician.

This problem may be caused by a malfunctioning or broken component that requires service.

## Maintaining the Envelope Feeder

The envelope feeder requires very little maintenance; however, with normal use you will need to perform some routine maintenance tasks such as cleaning the envelope feeder.

### Cleaning the Exterior of the Envelope Feeder

Through normal use the exterior of the envelope feeder may become dirty or stained with toner. Although exterior dirt should not affect printer performance, an occasional exterior cleaning may be necessary to maintain the appearance of the envelope feeder.

1. Turn the printer off by pressing [ O ] on the power switch on the right side of the printer.
2. Remove the plug of the AC power cord from the AC wall outlet.
3. Using a soft cloth, slightly damp with cold water, wipe the envelope feeder covers and tray faces. Use a very mild, non-abrasive soap to remove heavy dirt and toner stains.



**CAUTION:** Do not use solvents or abrasive cleaners to clean envelope feeder covers. Use only cold water and a very mild soap to clean covers.

- 
4. Using a soft, dry cloth, thoroughly dry the covers and tray faces.
    - . Insert the plug of the AC power cord into the AC wall outlet, and turn the printer on by pressing [ I ] on the power switch on the right side of the printer.



# Chapter 9

## Using the Offset Catch Tray

### In this Chapter . . .

- “About this Chapter” on page 9-2
- “About the Offset Catch Tray” on page 9-2
- “Installing the Offset Catch Tray” on page 9-3
- “Testing the Offset Catch Tray” on page 9-10
- “Solving Offset Catch Tray Problems” on page 9-10
- “Maintaining the Offset Catch Tray” on page 9-16
- “Moving the Offset Catch Tray” on page 9-16

## About this Chapter

This chapter provides all of the information necessary to install, use, and maintain the **Offset Catch Tray**, including procedures for cleaning and removing paper jams.

## About the Offset Catch Tray

The offset catch tray is an optional output tray that attaches to the top rear of the printer and can hold up to 500 printed sheets, and also sorts printed sheets using an offset. The printer supplies all of the operating power that is needed by the offset catch tray. Motors and circuit boards internal to the offset catch tray provide it with drive and operational logic.

The offset catch tray can be installed with only the printer, or it may be installed with other paper-handling options.

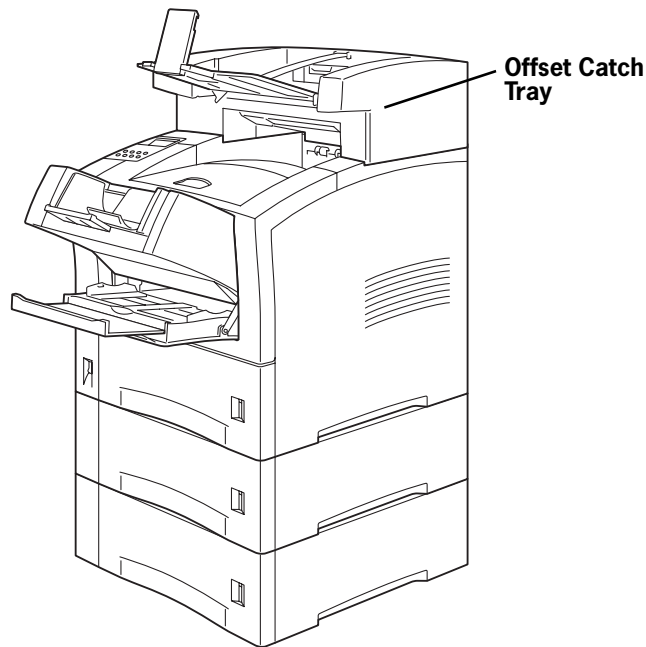

**Figure 9-1: Offset Catch Tray installed with other paper handling options.**

## Major Components of the Offset Catch Tray

The following illustration shows the major components of the offset catch tray:.

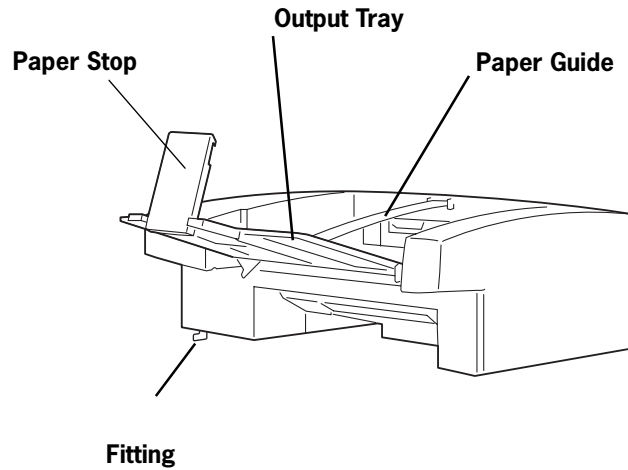

Figure 9-2: Offset Catch Tray Major Components.

## Installing the Offset Catch Tray

Before installing the offset catch tray, remove it from its packaging and verify that you have received an offset catch tray and that it is in good condition. If any part of the offset catch tray is missing or damaged, contact your dealer.

Throughout this procedure, the different sides of the printer are referred to as front, rear, left, and right. The front of the printer is the side that holds the control panel. The left and right sides are those to the left and right, respectively, of a person facing the front of the printer.

Use the following procedure to install the offset catch tray:

1. Remove any cardboard inserts or packing tape from the interior and exterior of the offset catch tray.
2. Turn the printer off by pressing [ O ] on the power switch on the front left of the printer, and disconnect the power cord from the AC outlet.

**NOTE:** Installing the offset catch tray while the printer is on may damage the printer or the offset catch tray.

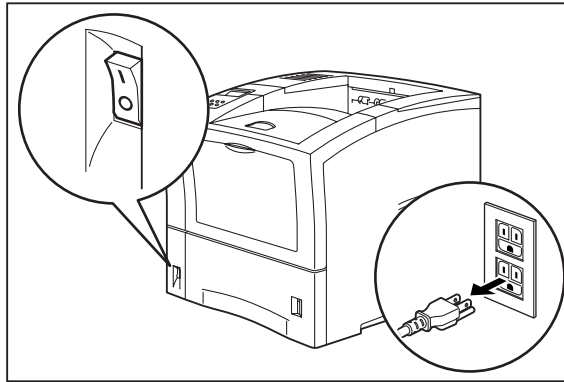

3. Squeeze the latch on the top left of the rear cover to release the cover, then open the rear cover by pulling down on the top of the cover.

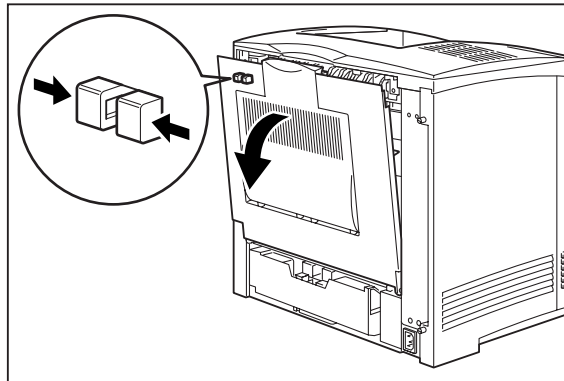



4. Push up on the top cover tabs to release the top cover, and lift it off of the printer.

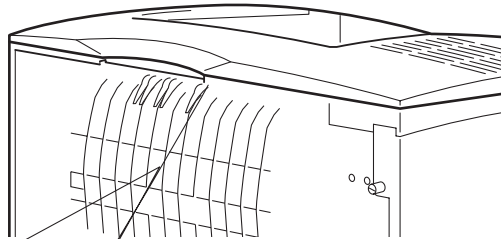

5. Lower the offset catch tray onto the printer while inserting the stub at the front of the offset catch tray into the hole on the top of the printer.

6. Insert the tabs on the back of the offset catch tray into the holes on the back of the printer, and push down until you hear the tabs click in place.

7. Close the rear cover.

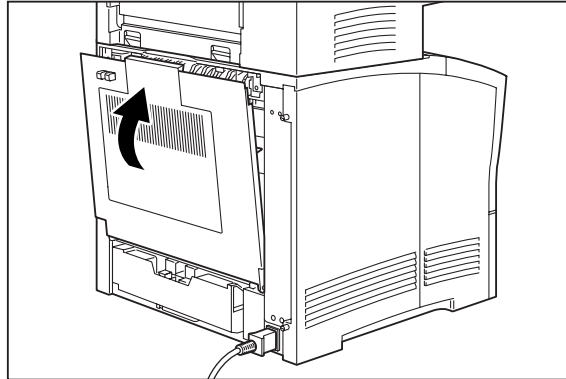

8. Lift up the paper guide and open the offset tray.

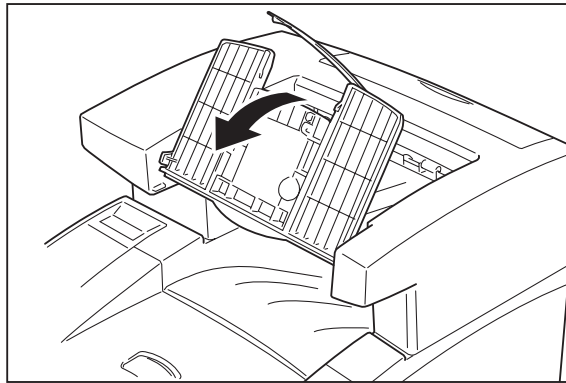

9. Pull the tray all the way out and lift the paper stop.

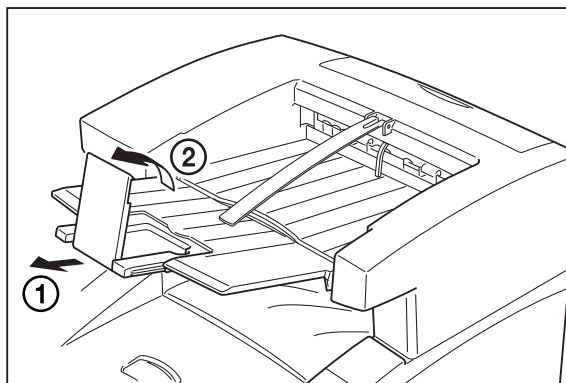

10. Push the tray in until it matches the size of paper that will be printed.

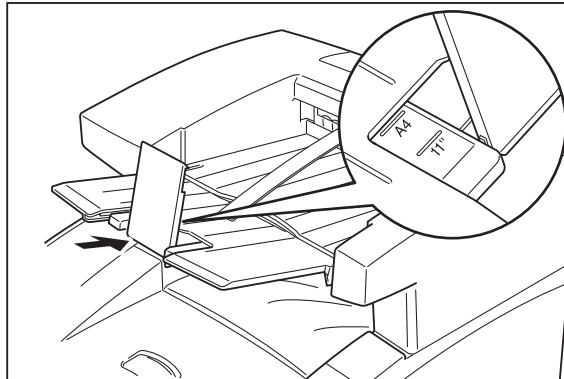

11. Insert the plug of the power cord into the AC outlet and turn the printer on by pressing [ I ] on the power switch on the front left of the printer.
12. Check the display to make sure the printer is ready for printing.

---

**NOTE:** If an error message is shown when you turn the printer on, refer to **Chapter 5: Troubleshooting**.

---

## Removing the Offset Catch Tray

Use the following procedure to remove the offset catch tray:

1. Pull the output tray all the way out and lower the paper stop.

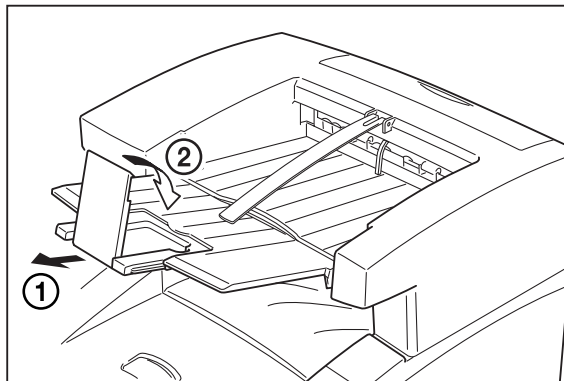

2. Push the paper stop into the output tray.

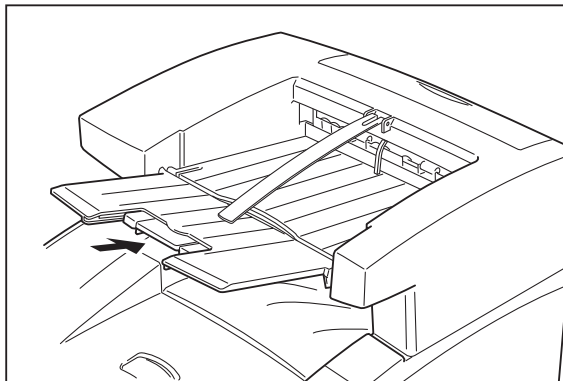

3. Lift the paper guide and fold up the output tray.

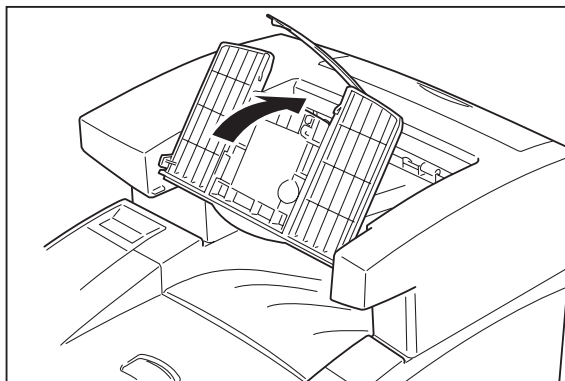

4. Turn the printer off by pressing [ O ] on the power switch on the front left of the printer, and disconnect the power cord from the AC outlet.

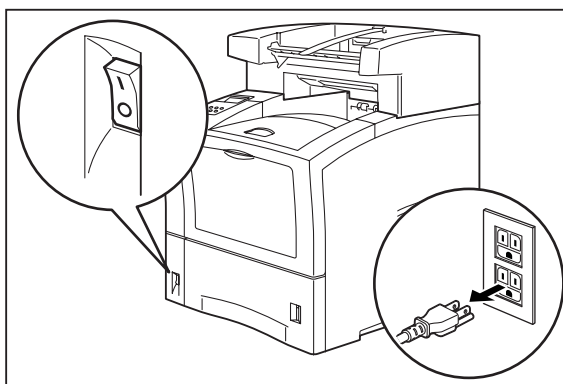

- Squeeze the latch on the upper left of the rear cover of the printer, and pull the cover toward you to open it.

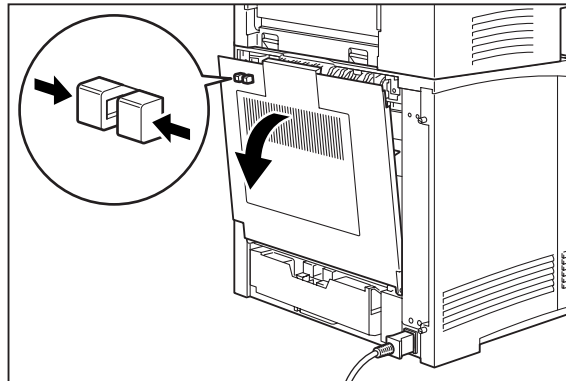

- 6. Press the tabs on the rear of the offset catch tray to release it and lift it off of the printer.

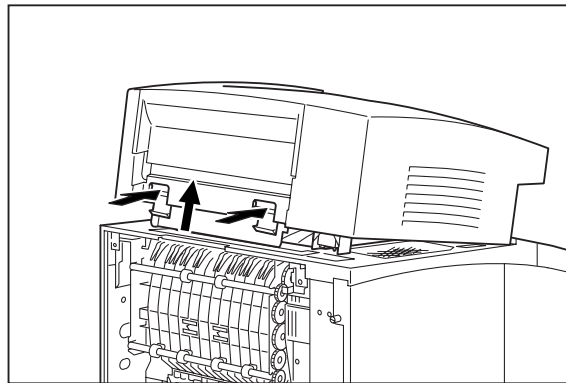

- 7. Replace the top cover of the printer.

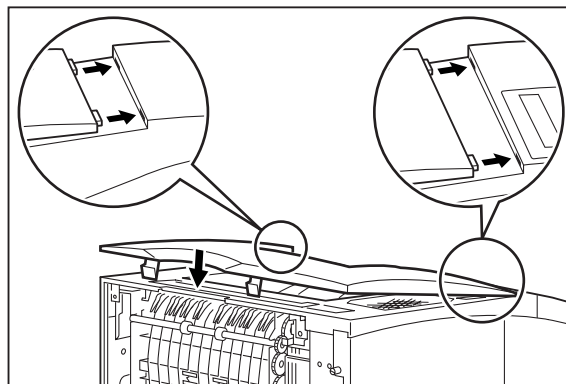

8. Close the rear cover of the printer.

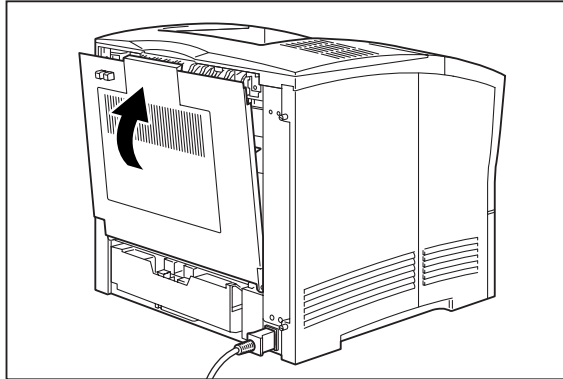

### Testing the Offset Catch Tray

After installing the offset catch tray, use the following test procedure to verify that it is operating correctly.

1. Turn the printer on by pressing the [ I ] on the power switch on the front left of the printer.
2. Once the printer has warmed up and displays the “Ready” message on the control panel display, use any software application to print a few sheets to the offset catch tray.
3. If the feeder does not feed paper or if the control panel displays an error message, refer to “Solving Offset Catch Tray Problems” on page 9-10.

### Solving Offset Catch Tray Problems

When there is a problem with the offset catch tray, the printer control panel displays an error code and error message. Most offset catch tray error codes indicate routine status conditions such as a paper jam. Some error codes indicate much more serious problems that may require the help of a service technician.

- If the offset catch tray is inoperative after installation, refer to “Installation Problems” on page 9-11 and complete the recommended procedure.
- If the printer control panel displays an error message or an error code, refer to “Interpreting Offset Catch Tray Error Messages” on page 9-11.
- If you have an offset catch tray problem but the printer control panel does not display an error message or error code, refer to “Correcting Miscellaneous Offset Catch Tray Problems” on page 9-13 and follow the directions for correcting that problem.

### Interpreting Offset Catch Tray Error Messages

The printer control panel displays error messages when there is a problem with the printer or any of the optional paper-handling components. The following table lists all of the error messages associated with the offset catch tray, the possible cause of the error, and the action to take to correct the problem. If the control panel shows an error message that concerns another part of the printer, refer to **Chapter : Troubleshooting** for a complete list of all warning and error messages.

Error or Warning Message Line 1	Error or Warning Message Line 2	Possible Cause	Action
(Warning message, printer continues operating and line 1 shows printer status.)	Offset Tray Full	The offset catch tray is full.	Remove paper from the tray.
<b>E6 JAM OFF. TRAY</b>	Remove paper	There is a jam at the offset catch tray.	Remove the paper jam. See "Clearing an Offset Catch Tray Paper Jam" on page 9-12.
<b>OFFSET TRAY FULL</b>	Remove Paper	The offset catch tray is full.	Remove paper from the tray.
<b>OFFSET TRAY FAIL</b>	Call Service	The offset tray has failed.	Turn the printer off, then turn it on. If the problem reoccurs, contact an authorized service provider.

### Installation Problems

Simple oversights during installation may cause problems when you first use the offset catch tray. If the offset catch tray is inoperative after you have installed it, use the following procedure to check several possible causes.

1. Turn the printer off by pressing the [ O ] on the power switch on the right side of the printer.
2. Make sure that the offset catch tray is firmly attached to the printer.

If the offset catch tray is firmly attached but the offset catch tray is still inoperative, return to the installation procedure and carefully repeat all of the installation steps.

3. If the offset catch tray is still inoperative after reinstallation, remove it from the printer so you can run tests on the printer alone.
4. Print a few sheets of paper to the main output tray to make sure the printer is still operational.
  - If the printer is operational when the offset catch tray is not attached, contact either your sales representative or a service technician and report your problem.
  - If the printer is not operational when the offset catch tray is not attached, refer to **Chapter : Troubleshooting** for procedures to correct printer problems. After correcting the printer problem, return to this chapter to reinstall the offset catch tray.

### Clearing an Offset Catch Tray Paper Jam

If an E6 error code precedes the error message on the first line of the control panel display, paper has jammed at the offset catch tray. Use the following procedure to clear a paper jam in this location:

1. Pull on the recessed area on the rear of the offset catch tray to open the rear cover.

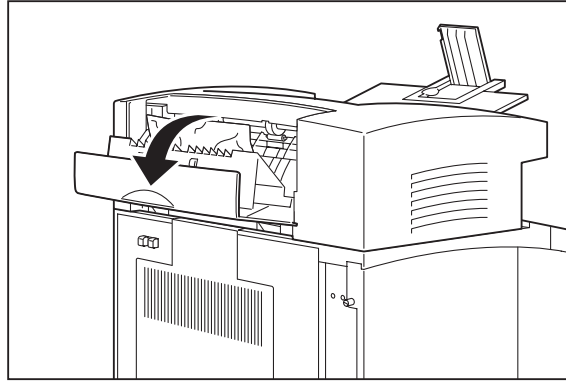

2. Remove any jammed paper from the interior of the offset catch tray.

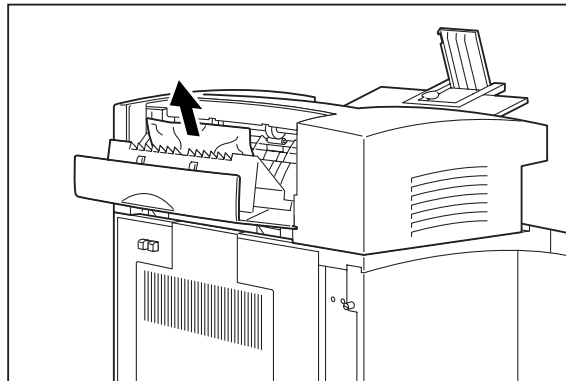

3. Close the rear cover of the offset catch tray.

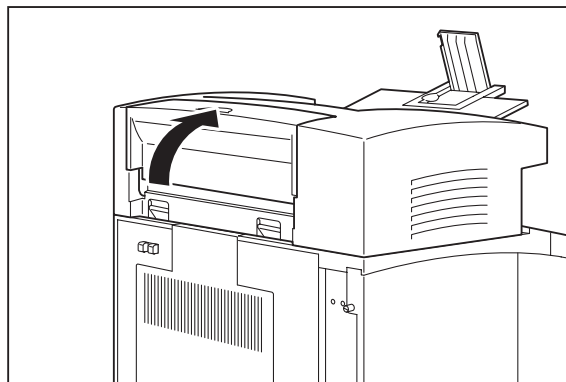

4. Squeeze the latch on the upper part of the rear cover, and pull the cover toward you to open it. Remove any paper that is stuck behind the rear cover.



**NOTE:** If the main paper tray is in the extended position, remove the tray before opening the rear cover.

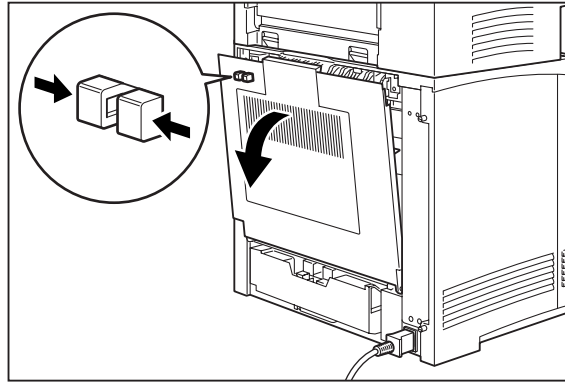

- Close the rear cover.

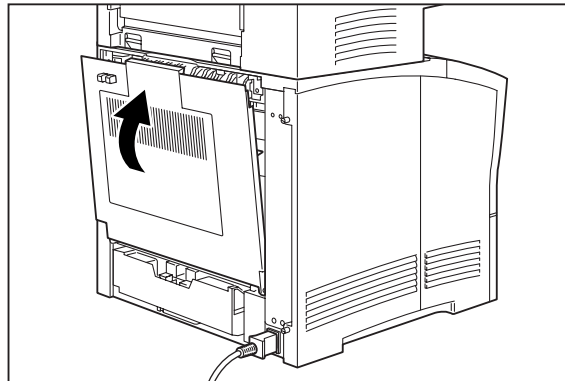

### Correcting Miscellaneous Offset Catch Tray Problems

Some offset catch tray problems may not cause an error message and may not interfere with the operation of the printer. If you are experiencing one of the problems listed below and there is no error message shown on the control panel display, refer to the procedures in the following sections to check the possible causes of the specific problem.

- Inoperative offset catch tray
- Erratic operation
- Unusual noise

#### *Inoperative Offset Catch Tray*

The following characteristics define this feeder problem:

- The offset catch tray appears to be inoperative.
- When attempting to print to the offset catch tray, the offset catch tray does not respond and does not transport paper.
- The control panel does not display an error code.

The following procedure guides you through multiple actions that may solve this offset catch tray problem. Proceed one step at a time until the problem is solved—you may not need to complete the entire procedure. If one of the steps in this procedure corrects the problem but the identical problem returns in less than 50 prints, call for service.

1. Open and then firmly close all of the printer and offset catch tray doors and covers.

Interlock switches monitor the position of printer doors and covers. When a door is closed, the interlock switch is activated and the offset catch tray can operate. When a door is open, the interlock switch is not activated and the offset catch tray cannot operate. If a door is not firmly closed, the interlock switch may not be fully activated—resulting in an inoperative offset catch tray.

2. Examine the printer driver settings to make sure the offset catch tray is available as an installed option. If the offset catch tray is correctly set as an installed option, reload the printer driver software.

The printer driver software running on the host computer may be damaged. Reinstalling the software is an easy and inexpensive way to isolate or eliminate the problem. Refer to the **DRIVERS** folder on the Electronic Library CD-ROM for detailed instructions on installing the driver.

3. Call your service technician.

This problem may be caused by a malfunctioning or broken component that requires service.

#### *Offset Catch Tray Operates Erratically*

The following characteristics define this offset catch tray problem:

- The offset catch tray does not function correctly.
- The offset catch tray does not transport paper, or transports paper without a request.
- The control panel does not display an error code.

The following procedure guides you through multiple actions that may solve this offset catch tray problem. Proceed one step at a time until the problem is solved—you may not need to complete the entire procedure. If one of the steps in this procedure corrects the problem but the identical problem returns in less than 50 prints, call for service.

1. Open and then firmly close all of the printer and offset catch tray doors and covers.

Interlock switches monitor the position of printer doors and covers. When a door is closed, the interlock switch is activated and the offset catch tray can operate. When a door is open, the interlock switch is not activated and the offset catch tray cannot operate. If a door is not firmly closed, the interlock switch can bounce between being activated and being not activated—confusing the system and causing erratic operation.

2. Reinstall the printer driver software.

The printer driver software running on the host computer may be damaged. Reinstalling the software is an easy and inexpensive way to isolate or eliminate the problem. Refer to the **DRIVERS** folder on the Electronic Library CD-ROM for detailed instructions on installing the drivers.

3. Call your service technician.

This problem may be caused by a malfunctioning or broken component that requires service.

### *Offset Catch Tray Makes Unusual Noises*

The following characteristics define this offset catch tray problem:

- The offset catch tray makes unusual noises or makes more noise than usual either while idle or while printing.
- The offset catch tray transports paper without a problem.
- The control panel does not display an error code.

The following procedure guides you through multiple actions that may solve this offset catch tray problem. Proceed one step at a time until the problem is solved—you may not need to complete the entire procedure. If one of the steps in this procedure corrects the problem but the identical problem returns in less than 50 prints, call for service.

1. Open the offset catch tray cover and inspect the inside for jammed paper or obviously damaged parts.

Broken components or scraps of paper lodged inside the offset catch tray may be brushing against moving parts and causing the noise.

2. Call your service technician.

This problem may be caused by a malfunctioning or broken component that requires service.

### *Offset Catch Tray will not Offset*

The following characteristics define this offset catch tray problem:

- The offset catch tray does not offset printed sheets.
- The offset catch tray transports paper without a problem.
- The control panel does not display an error code.

The following procedure guides you through multiple actions that may solve this offset catch tray problem. Proceed one step at a time until the problem is solved—you may not need to complete the entire procedure. If one of the steps in this procedure corrects the problem but the identical problem returns in less than 50 prints, call for service.

1. Open the offset catch tray cover and inspect the inside for jammed paper or obviously damaged parts.

Broken components or scraps of paper lodged inside the offset catch tray may be wedged against moving parts, preventing the offset roll from moving.

2. Call your service technician.

This problem may be caused by a malfunctioning or broken component that requires service.

## Maintaining the Offset Catch Tray

The offset catch tray requires very little maintenance; however, with normal use you will need to perform some routine maintenance tasks such as cleaning.

### Cleaning the Exterior of the Offset Catch Tray

Through normal use the exterior of the offset catch tray may become dirty or stained with toner. Although exterior dirt should not affect printer performance, an occasional exterior cleaning may be necessary to maintain the appearance of the offset catch tray.

1. Turn the printer off by pressing [ O ] on the power switch on the right side of the printer.
2. Remove the plug of the AC power cord from the AC wall outlet.
3. Using a soft cloth, slightly damp with cold water, wipe the offset catch tray covers and tray faces. Use a very mild, non-abrasive soap to remove heavy dirt and toner stains.



**CAUTION:** Do not use solvents or abrasive cleaners to clean offset catch tray covers. Use only cold water and a very mild soap to clean covers.

---

4. Using a soft, dry cloth, thoroughly dry the covers and tray faces.
  - . Insert the plug of the AC power cord into the AC wall outlet, and turn the printer on by pressing [ I ] on the power switch on the right side of the printer.

## Moving the Offset Catch Tray

### Moving the Offset Catch Tray a Short Distance

Use the following procedure to move the offset catch tray a short distance:

1. Turn the printer off by pressing the [ O ] on the power switch on the right side of the printer.
2. Disconnect the plug of the AC power cord from the AC wall outlet.
3. Disconnect the printer from the host computer.
4. Wait 30 minutes for the printer to cool before moving the printer.
  - . Remove the toner cartridge and cover it with an opaque plastic sheet.
6. With the help of another person, grasp the recessed areas on the bottom of the printer and lift the printer. Carefully carry the printer to the new location.
7. Once the printer and offset catch tray are in the new location, refer to the printer **Installation Guide** included in the original packaging to reinstall the printer.

### Moving the Offset Catch Tray a Long Distance

1. Turn the printer off by pressing the [ O ] on the power switch on the right side of the printer.
2. Disconnect the plug of the AC power cord from the AC wall outlet, and disconnect the AC power cord from the printer.
3. Disconnect the printer from the host computer.

4. Fold the output paper tray into the offset catch tray.
  - . Remove the offset catch tray off of the printer. Refer to “Removing the Offset Catch Tray” on page 9-7 for complete instructions.
6. Remove the offset catch tray cover from the top rear of the printer and replace it with the original printer cover.
7. Repack the offset catch tray components in the original packaging.
8. Once the offset catch tray is in the new location, refer to “Installing the Offset Catch Tray” on page 9-3.





# Chapter 10

## Using the Face Up Tray

### In this Chapter . . .

- “About this Chapter” on page 10-2
- “About the Face Up Tray” on page 10-2
- “Installing the Face Up Tray” on page 10-3
- “Testing the Face Up Tray” on page 10-9
- “Solving Face Up Tray Problems” on page 10-9

## About this Chapter

This chapter provides all of the information necessary to install and remove the Face Up Tray.

## About the Face Up Tray

The face up tray is an optional output tray that attaches to the top rear of the printer and can hold up to 100 printed sheets.

The face up tray can be installed with only the printer, or it may be installed with other paper-handling options.

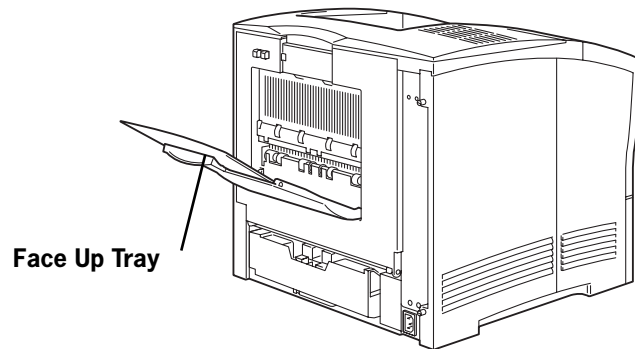

Figure 10-3: Face Up Tray installed with the printer.

## Major Components of the Face Up Tray

The following illustration shows the face up tray:.

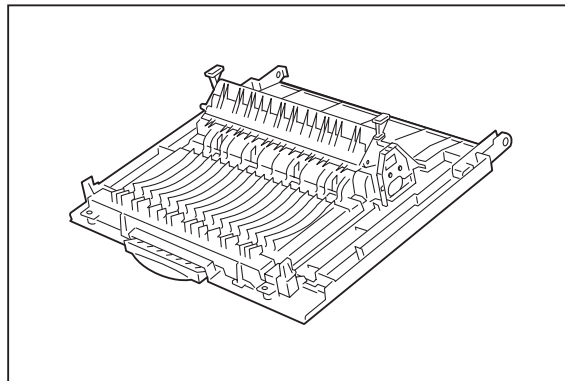

Figure 10-1: Face Up Tray.



## Installing the Face Up Tray

Before installing the face up tray, remove it from its packaging and verify that you have received an face up tray and that it is in good condition. If any part of the face up tray is missing or damaged, contact your dealer.

Use the following procedure to install the face up tray:

1. Remove any cardboard inserts or packing tape from the interior and exterior of the face up tray.
2. Turn the printer off by pressing [ O ] on the power switch on the front left of the printer, and disconnect the power cord from the AC outlet.

---

**NOTE:** Installing the face up tray while the printer is on may damage the printer or the face up tray.

---

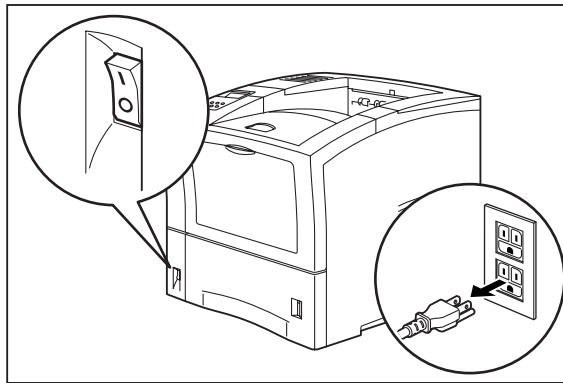

3. Squeeze the latch on the top left of the rear cover to release the cover, then open the rear cover by pulling down on the top of the cover.

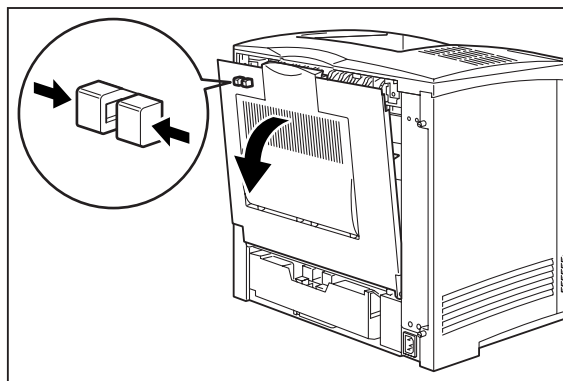

4. Remove the belt attached to the belt hole on the inside of the rear cover.

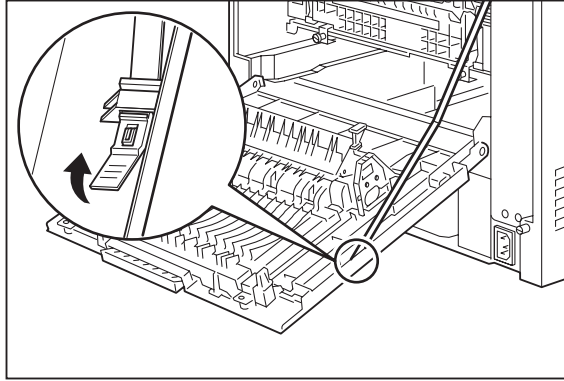

5. Squeeze the lock clip on the inside right of the rear cover, and slide it toward you.

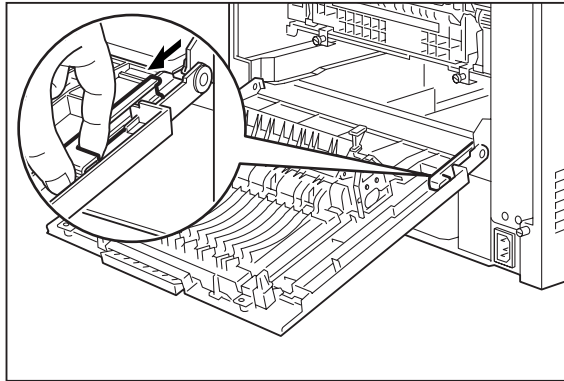

6. Slide the rear cover to the right, and remove it from the printer. Store the rear cover in a safe place.

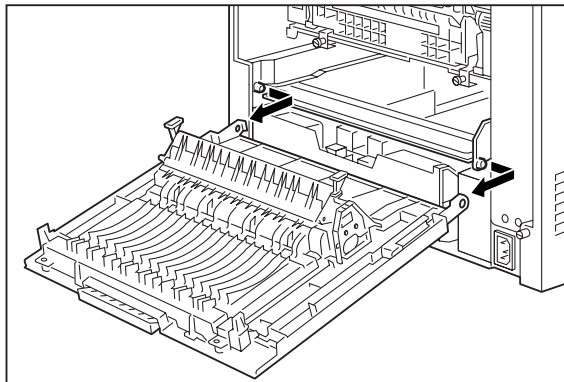

7. Place the holes in the left and right sides of the face up tray over the stubs on the inside of the printer, and slide the face up tray to the left.

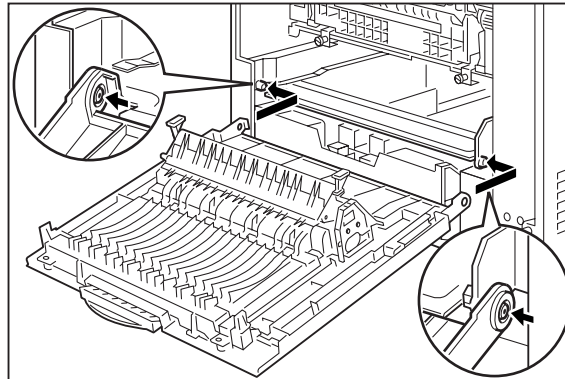

8. Slide the lock back to its original position.

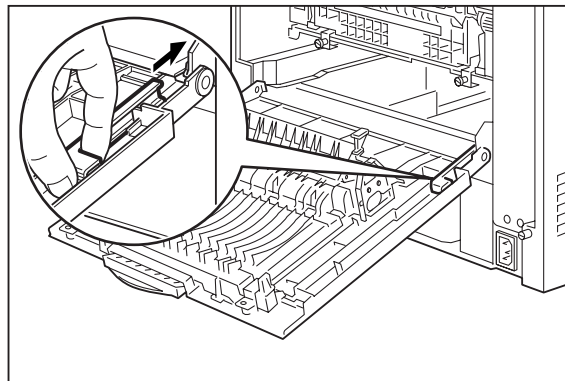

9. Insert the belt into the belt hole on the inside of the face up tray.

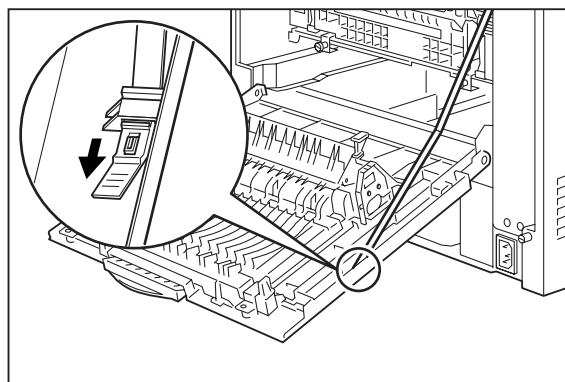

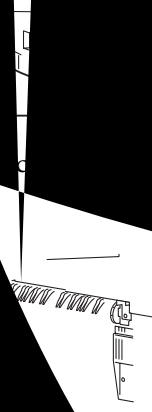

3. Remove the belt attached to the belt hole on the inside of the face up tray.

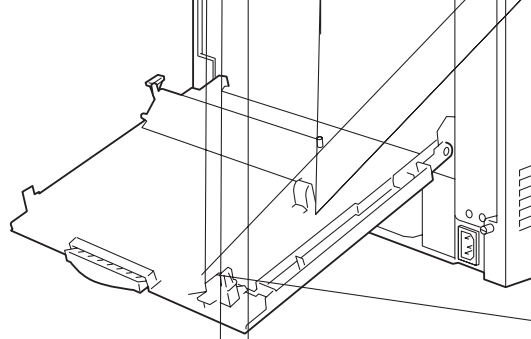

4. Squeeze the lock clip on the inside right of the face up tray, and slide it toward you.

- Slide the rear cover to the right, and remove it from the printer. Store the rear cover in a safe place.

6. Place the holes in the left and right sides of the rear cover over the stubs on the inside of the printer, and slide the rear cover to the left.

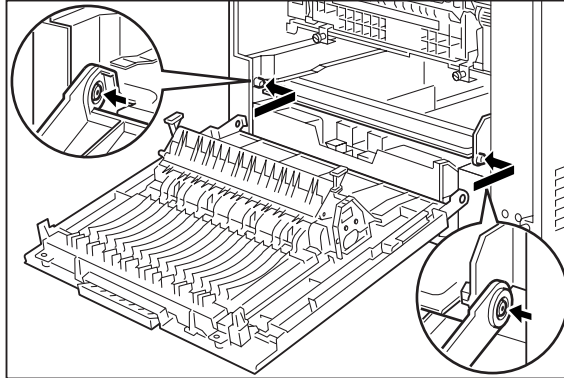

7. Slide the lock back to its original position.

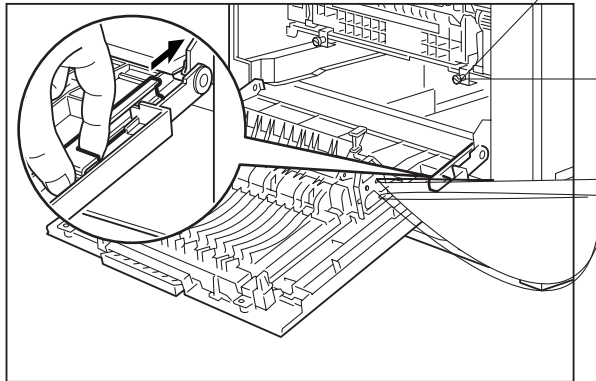

8. Insert the belt into the belt hole on the inside of the rear cover.

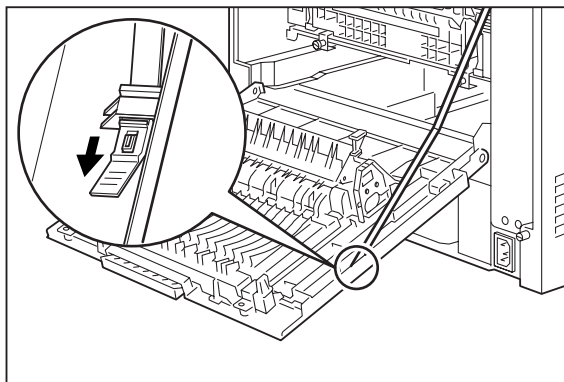

9. Close the rear cover.

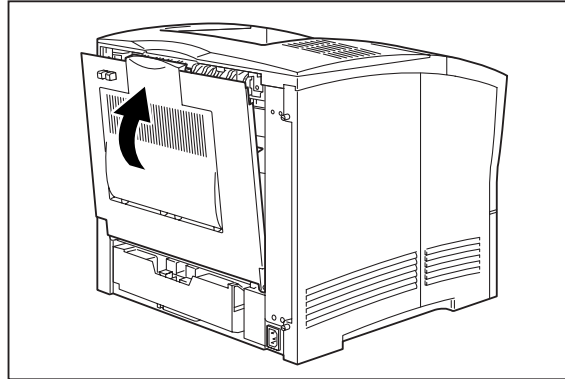

### Testing the Face Up Tray

After installing the face up tray, use the following test procedure to verify that it is operating correctly.

1. Turn the printer on by pressing the [ I ] on the power switch on the front left of the printer.
2. Once the printer has warmed up and displays the “Ready” message on the control panel display, use any software application to print a few sheets to the face up tray.
3. If the feeder does not feed paper or if the control panel displays an error message, refer to “Solving Face Up Tray Problems” on page 9-9.

### Solving Face Up Tray Problems

When there is a problem with the face up tray, the printer control panel displays an error code and error message. Most face up tray error codes indicate routine status conditions such as a paper jam. Some error codes indicate much more serious problems that may require the help of a service technician.

- If the face up tray is inoperative after installation, refer to “Installation Problems” on page 9-10 and complete the recommended procedure.
- If the printer control panel displays an error message or an error code, refer to “Interpreting Face Up Tray Error Messages” on page 9-10.

### Interpreting Face Up Tray Error Messages

The printer control panel displays error messages when there is a problem with the printer or any of the optional paper-handling components. The following table lists all of the error messages associated with the face up tray, the possible cause of the error, and the action to take to correct the problem. If the control panel shows an error message that concerns another part of the printer, refer to **Chapter : Troubleshooting** for a complete list of all warning and error messages.

Error or Warning Message Line 1	Error or Warning Message Line 2	Possible Cause	Action
PAPER PATH ERROR	Close Face Up	The face up tray is open when it should be closed.	Close the face up tray.

### Installation Problems

Simple oversights during installation may cause problems when you first use the face up tray. If the face up tray is inoperative after you have installed it, use the following procedure to check several possible causes.

1. Turn the printer off by pressing the [ O ] on the power switch on the right side of the printer.
2. Make sure that the face up tray is firmly attached to the printer.

If the face up tray is firmly attached but the face up tray is still inoperative, return to the installation procedure and carefully repeat all of the installation steps.

3. If the face up tray is still inoperative after reinstallation, remove it from the printer so you can run tests on the printer alone.
4. Print a few sheets of paper to the main output tray to make sure the printer is still operational.
  - If the printer is operational when the face up tray is not attached, contact either your sales representative or a service technician and report your problem.
  - If the printer is not operational when the face up tray is not attached, refer to **Chapter : Troubleshooting** for procedures to correct printer problems. After correcting the printer problem, return to this chapter to reinstall the face up tray.





## GENICOM Customer Support and Part Numbers

### In this Chapter . . .

- “About this Appendix” on page A-2
- “Sources of Support” on page A-2
- “GENICOM Worldwide Offices” on page A-3
- “GENICOM Part Numbers” on page A-6

## About this Appendix

This appendix explains the available sources of GENICOM Customer Support, and also lists contact information and locations of GENICOM worldwide offices. This appendix also lists the part numbers for GENICOM microLaser 210 printers, options, and consumables. To order parts, contact your local authorized GENICOM dealer.

## Sources of Support

There are several sources of Customer Support available to you, depending upon the type of assistance that you need.

### Your GENICOM Vendor

The local vendor that you purchased the printer through may be best equipped to help you with printer problems. Your vendor has specially trained service technicians available to answer questions, and also has equipment that is necessary to analyze printer problems.

### Your Application Vendor

Printing problems often have more to do with the application you are using than with the printer itself. Contact the manufacturer of the application in use for assistance in resolving such problems.

### Internet

The GENICOM server provides access to technical reports, new product announcements, a trade show schedule, and other general information about GENICOM.

You can access the GENICOM server via any one of the many world-wide web browsers available to Internet users. The GENICOM home page is <http://www.genicom.com>.

### GENICOM Technical Support

GENICOM Technical Support is available M-F, 8:00 am-8:00 pm, Eastern Time, (540) 949-1031(US). You can also fax questions to GENICOM Technical Support at (540) 949-1505 (US). Please indicate whether you would like a fax or telephone reply.

If you call for assistance, have the following information ready so our technicians can help you more quickly—also include this information with any question that you fax to GENICOM Technical Support:

- Your phone number, fax number, and shipping address
- A description of the problem
- The printer model
- The type of host computer you are using
- The type and version of operating system you are using
- The interface you are using, and, if serial, the protocol
- The application and version you are using
- The emulation you are using
- Your printer firmware version (listed on the status pages)

## GENICOM Service

If you have a hardware problem you cannot resolve, contact GENICOM Service at (888) 367-3772.

Other important GENICOM phone numbers:

- GENICOM Sales - (800) 436-4266
- GENICOM Parts - (800) 436-4266 x 2 x 3, Parts ID: (800) 436-4266 x 2 x 4
- GENICOM Supplies - (800) 436-4266 x 2 x 1

## GENICOM Worldwide Offices

The following table lists GENICOM offices worldwide:

<b>GENICOM United States</b>	
<b>GENICOM Corporation Corporate Headquarters</b>	GENICOM Corporation 14800 Conference Center Drive, Suite 400 Chantilly, VA 20151-3820 Telephone: 703-802-9200 Fax: 703-802-9039
<b>Document Solutions (Printer Products)</b>	Document Solutions One Solutions Way Waynesboro, VA 22980-1999 Telephone: 800-436-4266 or 540-949-1000 Fax: 540-949-1392
<b>Enterprising Service Solutions (ESSC)</b>	ESSC One Solutions Way Waynesboro, VA 22980 Telephone: 888-367-3772
<b>GENICOM Canada</b>	
<b>GENICOM Canada, Inc. Document Service Solutions Company (Printer Products)</b>	Document Service Solutions Company 5420 Timberlea Blvd. Mississauga, Ontario Canada L4W 2T7 Telephone: 800-268-0464 or 905-629-3700 Fax: 905-629-4976
<b>GENICOM Canada, Inc. Canadian Headquarters ESSC</b>	ESSC 100 Commerce Valley Drive East Thornhill, Ontario, Canada L3T 7R1 Telephone: 800-265-4146 or 905-882-2500 Fax: 905-882-0412
<b>GENICOM Worldwide</b>	
<b>GENICOM Australia</b>	GENICOM Pty. Ltd. 175 Gibbes Street, Unit 12 Chatswood, NSW 2067 Australia Telephone: 61 29 417 6411 Fax: 61 29 417 6739

<b>GENICOM Belgium</b>	GENICOM Belgium c/o Airport Business Center Vuurberg 80 B-1831 Machelen, Belgium Telephone: 32 2 712 6270 Fax: 32 2 720 5811
<b>GENICOM France</b>	GENICOM S.A. ZAC de Gatines 17, Ave du Garigliano 91601 Savigny-Sur-Orge, Cedex, France Telephone: 33 1 69 542317 Fax: 33 1 69 122050
<b>GENICOM Germany</b>	GENICOM GmbH Industriestraße 4 65779 Kelkheim/Ts. Telephone: 49 6195 9733-00 Fax: 49 6195 9733-90
	GENICOM GMBH Lilienthalstrasse 25 85399 Hallbergmoos, Germany Telephone: 49 811 80610 Fax: 49 811 80626
<b>GENICOM Hong Kong</b>	GENICOM Hong Kong Unit A, 21/F, Kyoto Plaza 491-499 Lockhart Road Causeway Bay, Hong Kong Telephone: 852 2832 9711 Fax: 852 2832 9977
<b>GENICOM Italy</b>	GENICOM SpA Via Achille Grandi 12 20093 Cologno Monzese Milan, Italy Telephone: 39 2 253041 Fax: 39 2 27302443
<b>GENICOM The Netherlands</b>	Genicom Europalaan 6a 5232 BC 's-Hertogenbosch The Netherlands Telephone: 31 736458150 Fax: 31 736446894

<b>GENICOM Singapore</b>	GENICOM Singapore 15 Beach Road #04-09 Beach Centre Singapore 189677, Singapore Telephone: 65 338 3438 Fax: 65 338 7336
<b>GENICOM U.K.</b>	GENICOM Limited Unit B13 Armstrong Mall Southwood Farnborough, Hampshire GU14 0NR United Kingdom Telephone: 44 1252 744400 Fax: 44 1252 523086

## GENICOM Part Numbers

The following tables list GENICOM part numbers for the microLaser 210 printer, options, and consumables.

### Printers

GENICOM Part Number	Description
3P7521A00GNM01	microLaser 210 Laser Printer, 110V
3P7521B00GNM01	microLaser 210 Laser Printer, 220V
3P7521A00GNM11	microLaser 210 Laser Printer, Ethernet, 110V
3P7521B00GNM11	microLaser 210 Laser Printer, Ethernet, 220V

### Paper Handling Options

GENICOM Part Number	Description
6A1236P01	microLaser 210 Duplexer
6A1237P01	microLaser 210 550-Sheet Universal Paper Tray
6A1238P01	microLaser 210 550-Sheet Feeder w/Universal Paper Tray
6A1239P01	microLaser 210 Envelope Feeder
6A1240P01	microLaser 210 Face Up Tray
6A1241P01	microLaser 210 Offset Catch Tray

### Network Interfaces

GENICOM Part Number	Description
6A0620P01	Ethernet Network Interface Card
6A0688P01	RS-232C/422 Serial Option
6A1255P01	IBM Coax/SCS Network Interface
6A1256P01	IBM Twinax/SCS Network Interface
6A1257P01	IBM Coax IPDS Network Interface
6A1258P01	IBM Twinax IPDS Network Interface
6A1269P01	LAN IPDS Interface

## DRAM, FLASH SIMM and Hard Disk Drive Options

GENICOM Part Number	Description
6A0621P01	32MB DRAM Memory SIMM
6A0622P01	FLASH SIMM Module
6A1253P01	Hard Disk Drive Option

## User Publications

GENICOM Part Number	Description
GEG-99067	GENICOM microLaser 210 Electronic Library Contents include but are not limited to the following documents: <ul style="list-style-type: none"> <li>■ GENICOM microLaser 210 User Guide</li> <li>■ Ethernet Network Interface Installation Guide (North American Version, includes English only)</li> <li>■ Ethernet Network Interface Reference Guide</li> <li>■ Hard Disk Option Guide</li> <li>■ Serial Option Guide</li> </ul>
GEG-99065	GENICOM microLaser 210 Installation Guide (North American Version, includes English only) *also available on the Electronic Library CD-ROM
GEG-99066	GENICOM microLaser 210 Installation Guide (International Version, includes English, French, German, Italian, and Spanish.) *also available on the Electronic Library CD-ROM

## Consumables

GENICOM Part Number	Description
6A1235P01	microLaser 210 Toner Cartridge
6A1242P01	microLaser 210 Maintenance Kit, 110V
6A1243P01	microLaser 210 Maintenance Kit, 220V







# Appendix B

## Safety Notes and Regulatory Compliance

### In this Chapter . . .

- “About this Appendix” on page B-2
- “Safety Notes” on page B-2
- “Regulatory Compliance” on page B-2

## About this Appendix

This appendix lists important safety precautions and identifies the applicable regulatory compliances of your printer.

## Safety Notes

- Be sure to switch off and unplug the printer before accessing the interior of the printer for cleaning, maintenance, or fault clearance. Accessing the interior of a live machine exposes you to the risk of electric shock.
- Do not place the printer in a hot, humid, dusty, or poorly ventilated environment. Prolonged exposure to these adverse conditions may cause fire or expose you to electric shock.
- The printer is capable of operating normally within the following environmental limits:
  - Temperature range: XX°F -95°F (5°C -35°C)  
At high temperatures (95°F /35°C), humidity should be at or below 70%.
  - Humidity range: 15%-85% (no condensation)  
At maximum humidity (85%), temperature should be at or below 82°F(28°C).
- Stop operation immediately if your printer produces smoke, excessive heat, unusual noise, or smell. These conditions can indicate or result in a fire. Immediately switch off and unplug the printer, and contact your point of purchase.
- The fuser becomes very hot in normal operation. If a paper jam has occurred, turn the power off and wait at least 10 minutes before removing the drum cartridge and touching the fuser section.

## Regulatory Compliance

### Safety Compliance

This product conforms the following safety standards:

- UL1950
- CSA C22.2 No. 950
- EN 60950
- IEC 950
- 73/23/EEC

### *Class 1 Laser Device and CDRH Compliance*

This printer is certified as a Class 1 laser product under the U.S. Department of Health and Human Services (DHHS) Radiation Performance Standard according to the Radiation Control for Health and Safety Act of 1968. This certification indicates that the printer does not emit hazardous laser radiation. Since radiation emitted inside the printer is completely confined within the protective housings and external covers, the laser beam cannot escape from the machine during any phase of user operation.

The Center for Devices and Radiological Health (CDRH) of the U.S. Food and Drug Administration implemented regulations for laser products on August 1976. These regulations apply to laser products marketed in the United States. The label on the printer indicates compliance with the CDRH regulations and must be attached to laser products marketed in the United States.

## **EMC Compliance**

### *Class B Equipment*

This equipment has been tested and found to comply with the limits for a Class B digital device, pursuant to Part 15 of FCC rules. These limits are designed to provide reasonable protection against harmful interference in a residential installation. Changes or modifications not expressly approved by the party responsible for compliance could void the user's authority to operate the equipment.

This equipment generates, uses, and can radiate radio frequency energy. If the equipment is not installed and used in accordance with the instructions, it may cause harmful interference to radio communications. However, there is no guarantee that interference will not occur in a particular installation. If this equipment does cause interference to radio or television reception, which can be determined by turning the equipment off and on, try to correct the interference using one or more of the following measures:

- Reorient or relocate the receiving antenna.
- Increase the separation between the equipment and receiver.
- Connect the equipment and the receiver to outlets that are on different circuits.
- Consult with the dealer or an experienced radio/television technician to help.
- Always use the power cord provided with your machine. When an extension cord is required, always use a properly rated cord.
- In countries other than the United States, please contact your point of purchase.

If your machine is a 220-240V model, there is no need to attach a separate earth line since the earth connection is incorporated in the power line. Plug it into a properly rated outlet.

The use of a non-shielded interface cable with the reference devices is prohibited. Shielded interface cables must not exceed the following limitations:

- The length of the IEEE 1284 parallel interface cable must be 50 feet (15 meters) or less.
- The length of the Ethernet interface cable must be 328 feet (100 meters) or less for type 10/100BASE-T or 185 meters (607 feet) or less for type 10/BASE-2.
- The length of the power cord must be 10 feet (3 meters) or less.

### *Other EMC Standards*

This product also conforms to the following EMC standards:

- CNS 13438
- VCCI V-3/97.04
- AS/NZS 3548:1995 including A1:1997 and A2:1997
- EN55022: 1994 including A1:1995 and A2:1997
- FCC Part 15, Subpart B (CFR 47, 1995)
- CISPR22: 1993 including A1:1995 and A2:1996



## Free Manuals Download Website

<http://myh66.com>

<http://usermanuals.us>

<http://www.somanuals.com>

<http://www.4manuals.cc>

<http://www.manual-lib.com>

<http://www.404manual.com>

<http://www.luxmanual.com>

<http://aubethermostatmanual.com>

Golf course search by state

<http://golfingnear.com>

Email search by domain

<http://emailbydomain.com>

Auto manuals search

<http://auto.somanuals.com>

TV manuals search

<http://tv.somanuals.com>