

# Electrolux air-o-steam - level A

## Combi LW 20 GN 1/1-electric

Electrolux air-o-steam blends tradition with the latest technological research in order to satisfy the creativity and working requirements of today's professional kitchen. The air-o-steam range offers a choice of different models available in two levels of operation, providing a high degree of automation and an extensive range of accessories. The air-o-steam combis are designed to form complete cook&chill systems together with air-o-chill blast chillers/freezers, therefore, any installation can be tailored to meet the needs of the caterer. The air-o-steam combis detailed are level A, 20 GN 1/1 electric models.



267004

### OPERATING MODES

- Convection cycle (max. 300 °C): ideal for meat to be cooked without humidity and "au gratin". In conjunction with the half-power function for all kinds of pastry cooking. The humidity generated by the food itself can be controlled by air-o-clima with Lambda sensor for a natural cooking.
- Steam cycle (max. 130 °C): for products that can be cooked in water. Steam cooking respects the original properties of the food and reduces weight loss.
- Combi cycle (max. 250°C): ideal for most kinds of cooking. Impressive reduction of cooking times and food shrinkage. The humidity generated by the food and the steam generator can be controlled by air-o-clima with

- Lambda sensor for consistent results regardless of the food load.
- air-o-steam ovens can cook by controlling either the cooking time or the product's core temperature through a 6-sensor probe.
- Regeneration cycle: it produces the best humidity conditions for quickly heating the products to be regenerated (max. 250°C) on the plate.
- Fan speeds: full, half speed (for delicate cooking such as for baking cakes) and HOLD (pulse ventilation for baking and low temperature cooking). The "HOLD utility" is also perfect for keeping food warm at the end of the cooking cycle.
- Low power cycle: for delicate cooking such as for baking cakes.
- Eco-delta: the temperature

- inside the cooking cell is higher than the temperature of the food and rises accordingly.
- Low Temperature Cooking (LTC, automatic cycle): indicated for large pieces of meat, automatically selects the cooking parameters to achieve the lowest weight loss. It features ARTE (Algorithm for Remaining Time Estimation).
- Exhaust valve electronically controlled to extract the humidity excess.
- Break phase: set a time to delay the start of cooking programs or to program a break between two cooking cycles (for example to allow rising).
- 20 pre-set programs and 100 7-step free cooking programs.



**Electrolux**

**Electrolux air-o-steam - level A  
Combi LW 20 GN 1/1-electric**

- air-o-clean: 4 different pre-set cycles to clean the cooking cell, according to the actual requirements. The cleaning system is built-in (no need for add-ons).
- Quick cooling: useful when passing to a type of cooking that requires a lower temperature than the previous one. It works automatically and manually.
- Manual injection of water in the cell.
- Automatic steam generator water draining with an automatic scale diagnosis system.
- HACCP management as standard: it allows recording the cooking programme according to H.A.C.C.P. standard (Hazard Analysis and Critical Control Points). According to the system requested it will be possible to record the cooking data with the oven's printer (optional) or directly in a Personal Computer (PC network installation required).

**PERFORMANCE**

- air-o-clima: controls and displays the exact (single degree of accuracy) humidity degree of the oven atmosphere in hot air, combi and regeneration cycles. Air-o-clima measures physically the real humidity level inside the cooking cell and acts consequently according to the set value. With hot air cycles, air-o-clima also manages to exhaust the excess humidity generated by the food.
- air-o-flow: blows fresh air from outside through the bi-functional fan, which pulls the air in from the backside of the oven after it is pre-heated, thus guaranteeing an even cooking process.
- Multi-sensor food probe: 6 sensors, ½ °C accuracy.

**CONSTRUCTION**

- Stainless steel 304 throughout, with seamless joints in the cooking cell.

- Height adjustable legs.
- Double thermo-glazed door equipped with drip pans to catch condensate and prevent slippery floor for maximum security and four holding positions allowing easier loading and unloading.
- Halogen lighting in the cooking cell.
- Access to main components from the front panel.
- Automatic scale diagnosis system in the steam generator to detect the presence of scale build-up.
- IPX5 water protection.
- air-o-steam ovens meet IMQ safety requirements.

	AOS201EAA1 267004	AOS201EAH1 267014	AOS201EAN1 267024	AOS201EAK1 267104
<b>TECHNICAL DATA</b>				
Power supply	Electric	Electric	Electric	Electric
Number of grids	20	16	20	20
Runners pitch - mm	63	80	63	63
Cooking cycles - °C				
air-convection	300	300	300	300
steam	130	130	130	100
combi	250	250	250	250
Convection	●	●	●	●
Steaming	●	●	●	●
Convection/steaming	●	●	●	●
Humidity control	●	●	●	●
Cook&hold	●	●	●	●
Regeneration	●	●	●	●
Low temp steaming	●	●	●	●
Two-speed fan	●	●	●	●
Multi Point Probe	●	●	●	●
Automatic cleaning system	●	●	●	●
N° of programs	100	100	100	100
External dimensions - mm				
width	993	993	993	993
depth	957	957	957	957
height	1795	1795	1795	1795
Internal dimensions - mm				
width	460	460	460	460
depth	715	715	715	715
height	1450	1450	1450	1450
Power - kW				
boiler	24	24	20	24
auxiliary	0.8	0.8	0.8	0.8
electric	34.5	34.5	34.5	34.5
cooking chamber	34	34	34	34
Net weight - kg.	284	284	284	284
Supply voltage	400 V, 3N, 50/60	400 V, 3N, 50/60	230 V, 3, 50/60	400 V, 3N, 50/60

Internet: <http://www.electrolux.com/foodservice>

**Electrolux air-o-steam - level A  
Combi LW 20 GN 1/1-electric**

EGAO40

2010-04-13

	AOS201EAA1 267004	AOS201EAH1 267014	AOS201EAN1 267024	AOS201EAK1 267104
<b>INCLUDED ACCESSORIES</b>				
*NOT TRANSLATED*	1	1	1	1
CONTROL PANEL FILTER-20 GN1/1 OVENS-LW	1		1	1
TROLLEY TRAY RACK F. 20X1/1GN,63MM PITCH	1		1	1
TROLLEY TRAY RACK F.16X1/1GN,80MM PITCH		1		
<b>ACCESSORIES</b>				
*NOT TRANSLATED*	922086	922086	922086	922086
*NOT TRANSLATED*	922094	922094	922094	922094
*NOT TRANSLATED*	922165	922165	922165	922165
*NOT TRANSLATED*	922166	922166	922166	922166
*NOT TRANSLATED*	922189	922189	922189	922189
*NOT TRANSLATED*	922190	922190	922190	922190
*NOT TRANSLATED*	922191	922191	922191	922191
*NOT TRANSLATED*	922209	922209	922209	922209
*NOT TRANSLATED*	922215	922215	922215	922215
*NOT TRANSLATED*	922239	922239	922239	922239
*NOT TRANSLATED*	922275	922275	922275	922275
*NOT TRANSLATED*	922284	922284	922284	922284
*NOT TRANSLATED*	922285	922285	922285	922285
1 GRID GN1/1 FOR 8 WHOLE CHICKENS(1.2KG)	922266	922266	922266	922266
2 FAT FILTERS FOR 20X1/1 & 2/1 OVEN	922179	922179	922179	922179
2 GRIDS GN 1/1 FOR CHICKENS (8 PER GRID)	922036	922036	922036	922036
AUTOMATIC WATER SOFTENER FOR OVENS	921305	921305	921305	921305
BANQUET RACK-45PLATES-85MM PITCH-20GN1/1	922072	922072	922072	922072
BANQUET RACK-54PLATES-74MM PITCH-20GN1/1	922016	922016	922016	922016
CONTROL PANEL FILTER-20 GN1/1 OVENS-LW		922230		
EXTERNAL SIDE SPRAY UNIT	922171	922171	922171	922171
HEAT SHIELD FOR 20 GN 1/1 OVENS	922243	922243	922243	922243
NON-STICK U-PAN GN 1/1 H=20 MM	922090	922090	922090	922090
NON-STICK U-PAN GN 1/1 H=40 MM	922091	922091	922091	922091
NON-STICK U-PAN GN 1/1 H=65 MM	922092	922092	922092	922092
OVEN GRILL (ALUMINIUM) GN 1/1	922093	922093	922093	922093
PAIR OF 1/1GN AISI 304 GRIDS	922017	922017	922017	922017
PASTRY TROLLEY(400X600)-AOS 20GN1/1,80MM	922068	922068	922068	922068
RESIN SANITIZER FOR WATER SOFTENER	921306	921306	921306	921306
THERMAL BLANKET FOR 20X1/1GN	922014	922014	922014	922014
TROLLEY TRAY RACK F. 20X1/1GN,63MM PITCH	922007	922007	922007	922007
TROLLEY TRAY RACK F.16X1/1GN,80MM PITCH	922010	922010	922010	922010
WATER FILTER FOR 20 2/1 OVENS 1.8 L/MIN.	922104	922104	922104	922104

Internet: <http://www.electrolux.com/foodservice>

**Electrolux air-o-steam - level A  
Combi LW 20 GN 1/1-electric**

267004, 267104, 267024, 267014

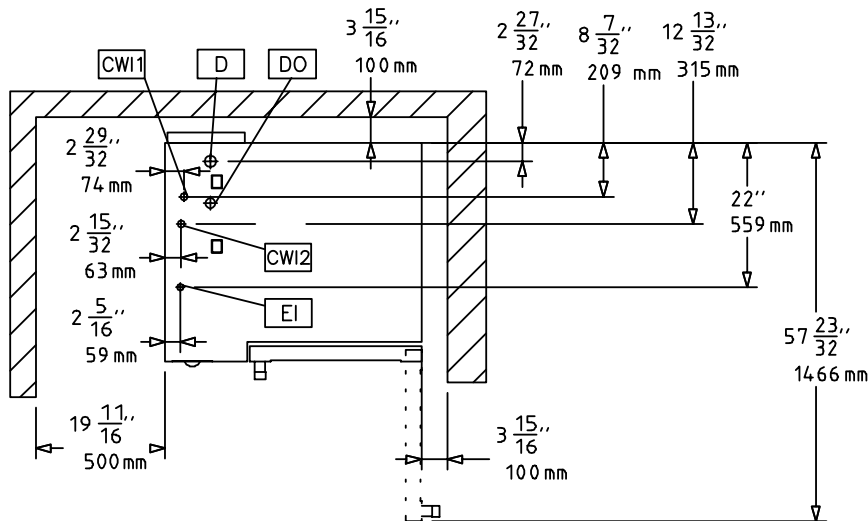
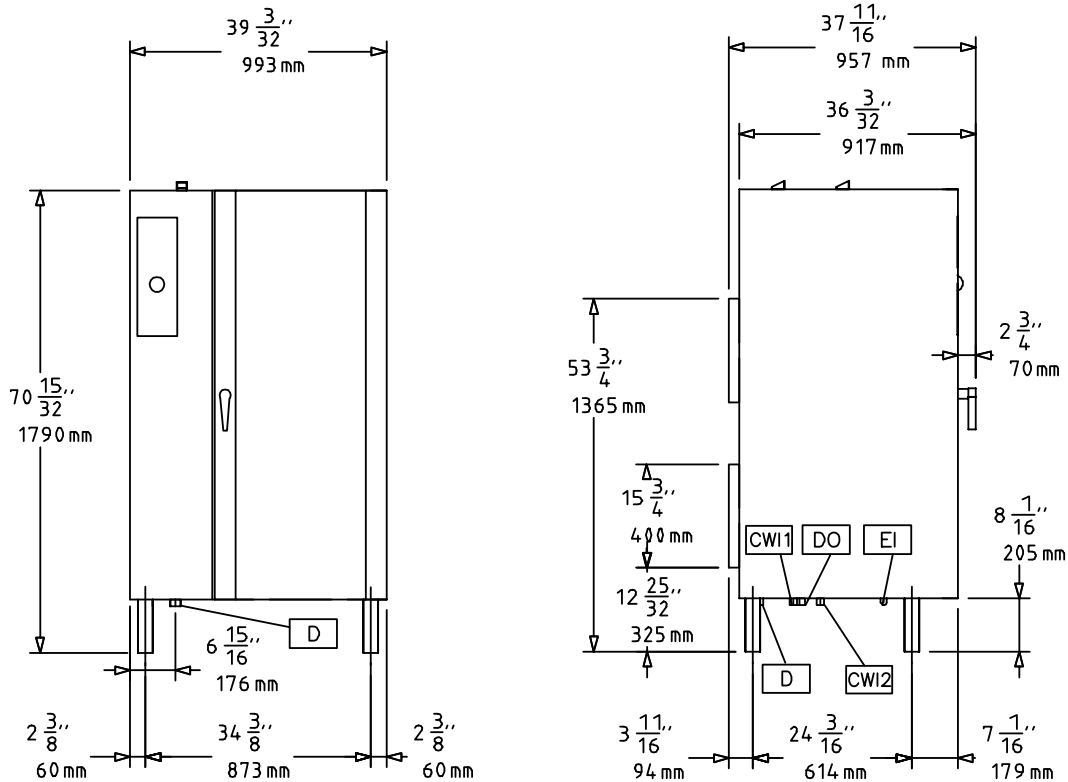

EGAO40  
2010-04-13

LEGEND	AOS201EAA1 267004	AOS201EAH1 267014	AOS201EAN1 267024	AOS201EAK1 267104
CWI - Cold water inlet	3/4"	3/4"	3/4"	3/4"
D - Water drain	1"1/4	1"1/4	1"1/4	1"1/4
DO - Overflow drain pipe	●	●	●	●
EI - Electrical connection	400 V, 3N, 50/60	400 V, 3N, 50/60	230 V, 3, 50/60	400 V, 3N, 50/60
WIC - Cooling water inlet	3/4"	3/4"	3/4"	3/4"

## Free Manuals Download Website

<http://myh66.com>

<http://usermanuals.us>

<http://www.somanuals.com>

<http://www.4manuals.cc>

<http://www.manual-lib.com>

<http://www.404manual.com>

<http://www.luxmanual.com>

<http://aubethermostatmanual.com>

Golf course search by state

<http://golfingnear.com>

Email search by domain

<http://emailbydomain.com>

Auto manuals search

<http://auto.somanuals.com>

TV manuals search

<http://tv.somanuals.com>