

Viscount[®] II Hydraulic Motor

307158ZAF
EN

Reciprocating hydraulic motor for use with Graco high performance coating pumps.



Important Safety Instructions

Read all warnings and instructions in this manual.
Save these instructions.

See page 2 for model information, including maximum hydraulic fluid input pressure.

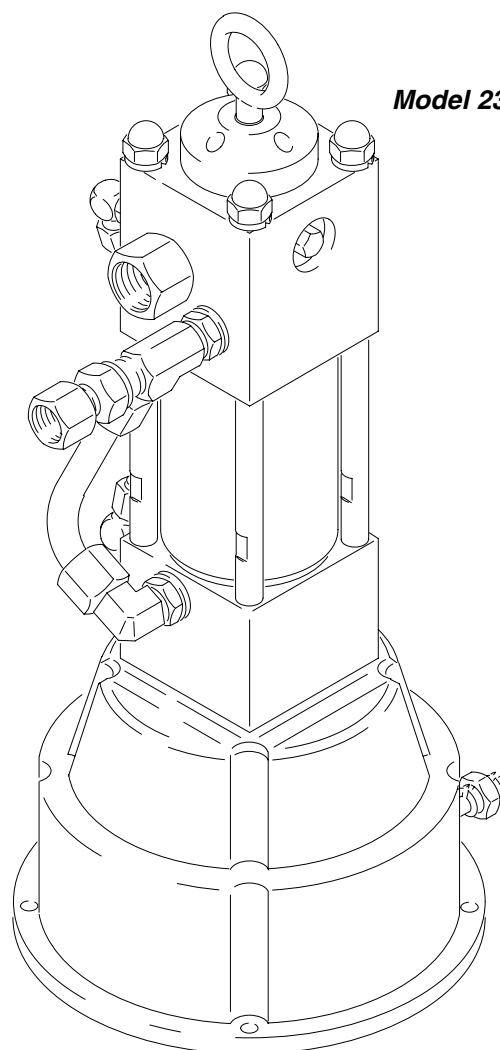

Model 235345

04471

PROVEN QUALITY. LEADING TECHNOLOGY.

Table of Contents

Warnings	3	Mounting Hole Layout	22
Installation	6	Dimensions	22
Service	8	Technical Data	23
Parts List & Drawings		Warranty	24
Model 217022	14	Graco Information	24
Model 217338	16		
Model 235345	18		
Model 262818 and 24W139	20		

Models

Model	Series	Maximum Hydraulic Fluid Input Pressure	Description
217022	D	1500 psi (10 MPa, 103 bar)	Replacement motor for GH533, GH733, and GH833 Sprayers
217338	E	1500 psi (10 MPa, 103 bar)	Replacement motor for Viscount® II Plural Component Pump
235345	A	1500 psi (10 MPa, 103 bar)	Viscount® II Motor, Interchanges with King® Air Motor
262818	A	1800 psi (12 MPa, 124 bar)	Replacement motor for XP and Xtreme Sprayer, Interchanges with NXT 6500 NXT Air Motor and 8 in. tie rod diameter lowers
24W139	A	1900 psi (13.1 MPa, 131 bar)	Hydraulic motor for Hydra-Clean® Sprayers, Interchanges with NXT 6500 NXT Air Motor and 8 in. tie rod diameter lowers

Warnings

Warning Symbol



This symbol alerts you to the possibility of serious injury or death if you do not follow the instructions.

Caution Symbol



This symbol alerts you to the possibility of damage to or destruction of equipment if you do not follow the corresponding instructions.

! WARNING



INSTRUCTIONS

EQUIPMENT MISUSE HAZARD

Equipment misuse can cause the equipment to rupture or malfunction and result in serious injury.

- This equipment is for professional use only.
- Read all instruction manuals, tags, and labels before operating the equipment.
- Use the equipment only for its intended purpose. If you are uncertain about usage, call your Graco distributor.
- Do not alter or modify this equipment. Use only genuine Graco parts and accessories.
- Check equipment daily. Repair or replace worn or damaged parts immediately.
- Do not exceed the maximum working pressure stated on the equipment or in the **Technical Data** for your equipment. Do not exceed the maximum working pressure of the lowest rated component in your system.
- Use fluids and solvents which are compatible with the equipment wetted parts. Refer to the **Technical Data** section of all equipment manuals. Read the fluid and solvent manufacturer's warnings.
- Handle hoses carefully. Do not pull on hoses to move equipment.
- Route hoses away from traffic areas, sharp edges, moving parts, and hot surfaces. Do not expose Graco hoses to temperatures above 82°C (180°F) or below -40°C (-40°F).
- Do not move or lift pressurized equipment.
- Wear hearing protection when operating this equipment.
- Comply with all applicable local, state, and national fire, electrical, and safety regulations.

WARNING

SKIN INJECTION HAZARD



Spray from the gun, hose leaks or ruptured components can inject fluid into your body and cause extremely serious injury, including the need for amputation. Fluid splashed in the eyes or on the skin can also cause serious injury.



- Fluid injected into the skin might look like just a cut, but it is a serious injury. **Get immediate surgical treatment.**
- Do not point the gun at anyone or at any part of the body.
- Do not put your hand or fingers over the spray tip.
- Do not stop or deflect leaks with your hand, body, glove or rag.
- Do not “blow back” fluid; this is not an air spray system.
- Always have the tip guard and the trigger guard on the gun when spraying.
- Check the gun diffuser operation weekly. Refer to the gun manual.
- Be sure the gun trigger safety operates before spraying.
- Lock the gun trigger safety when you stop spraying.
- Follow the **Pressure Relief Procedure** on page 8 if the spray tip clogs and before cleaning, checking or servicing the equipment.
- Tighten all fluid connections before operating the equipment.
- Check the hoses, tubes, and couplings daily. Replace worn, damaged, or loose parts immediately. Permanently coupled hoses cannot be repaired; replace the entire hose.
- Use only Graco approved hoses. Do not remove any spring guard that is used to help protect the hose from rupture caused by kinks or bends near the couplings.



MOVING PARTS HAZARD

Moving parts can pinch or amputate your fingers.

- Keep clear of all moving parts when starting or operating the pump.
- Before servicing the equipment, follow the **Pressure Relief Procedure** on page 8 to prevent the equipment from starting unexpectedly.

WARNING



FIRE AND EXPLOSION HAZARD

Improper grounding, poor ventilation, open flames or sparks can cause a hazardous condition and result in a fire or explosion and serious injury.

- Ground the equipment and the object being sprayed. Refer to **Grounding** on page 7.
- If there is any static sparking or you feel an electric shock while using this equipment, **stop spraying immediately**. Do not use the equipment until you identify and correct the problem.
- Provide fresh air ventilation to avoid the buildup of flammable fumes from solvents or the fluid being sprayed.
- Keep the spray area free of debris, including solvent, rags, and gasoline.
- Before operating this equipment, electrically disconnect all equipment in the spray area.
- Before operating this equipment, extinguish all open flames or pilot lights in the spray area.
- Do not smoke in the spray area.
- Do not turn on or off any light switch in the spray area while spraying or while there are any fumes in the air.
- Do not operate a gasoline engine in the spray area.



TOXIC FLUID HAZARD

Hazardous fluid or toxic fumes can cause serious injury or death if splashed in the eyes or on the skin, inhaled, or swallowed.

- Know the specific hazards of the fluid you are using.
- Store hazardous fluid in an approved container. Dispose of hazardous fluid according to all local, state and national guidelines.
- Always wear protective eyewear, gloves, clothing and respirator as recommended by the fluid and solvent manufacturer.

Installation

⚠ WARNING

Maximum Hydraulic Input Pressure

The maximum safe hydraulic input pressure to this motor depends on the lower displacement pump to which it is connected.

With Graco Displacement Pump Models 207474, 207655, 210208, 217527, 217339, 222796, 222801, 222803, 222805, 222810, and 222811 use a maximum of 1500 psi (10 MPa, 103 bar) hydraulic input pressure.

For Graco Displacement Pump Models 24B923 and 687055, use a maximum of 1900 psi (13.1 MPa, 131 bar) hydraulic input pressure.

Never exceed 1000 psi (7 MPa, 70 bar) hydraulic input pressure with the motor connected to any displacement pump other than those listed above; serious injury or damage to the equipment may result.

⚠ WARNING

To reduce the risk of serious injury whenever you are instructed to relieve pressure, always follow the **Pressure Relief Procedure** on page 8.

Be sure you always shut off the supply line shutoff valve (E) first, and then the return line shutoff valve. This is to prevent overpressurizing the motor or its seals. When starting up the hydraulic system, open the return line shutoff valve first.

⚠ CAUTION

Keep the hydraulic system clean

To reduce the risk of damaging the hydraulic power supply, blow out all hydraulic lines with air, flush thoroughly with solvent, and then blow out with air again before connecting the lines to the motor.

Always plug the hydraulic inlets, outlets and lines when disconnecting them to avoid introducing dirt and other contaminants into the system.

Carefully follow the manufacturer's recommendations on reservoir and filter cleaning, and periodic changes of hydraulic fluid.

⚠ CAUTION

Recommended Hydraulic Oil

Use Graco-approved Hydraulic Oil, Part No. 169236 (5 gal) or 207428 (1 gal) or a premium, ISO grade 46 petroleum-based hydraulic oil containing rust and oxidation inhibitors and anti-wear agents.

Before using any other type of oil in this motor, contact your Graco distributor. Unauthorized use of lesser grade oil or substitutes may void the warranty.

Hydraulic Oil Working Temperature Models 217022 and 217338

The recommended hydraulic oil operating temperature is 80 – 115°F (27 – 45°C). The motor seals will wear faster and leakage may occur if the pump is operated at higher oil temperatures.

If the hydraulic oil temperature approaches 130°F (54°C), check the hydraulic fluid supply cooling system, filters, etc. and clean or repair as needed.

Models 235435, 262818, and 24W139

The recommended hydraulic oil operating temperature is 80 – 160°F (27 – 71°C). The motor seals will wear faster and leakage may occur if the pump is operated at higher oil temperatures.

If the hydraulic oil temperature approaches 180°F (82°C), check the hydraulic fluid supply cooling system, filters, etc. and clean or repair as needed.

Refer to the complete pump manual for detailed installation information or contact your Graco distributor.

NOTE: A 1 in. npt seal (57) is supplied in a plastic bag with the motor. Thread the seal onto the threads of your hydraulic return line fitting (A). Thread the fitting into the upper housing (40) and torque as needed. Then tighten the seal (57) against the motor to provide a secure seal. See Fig. 1.

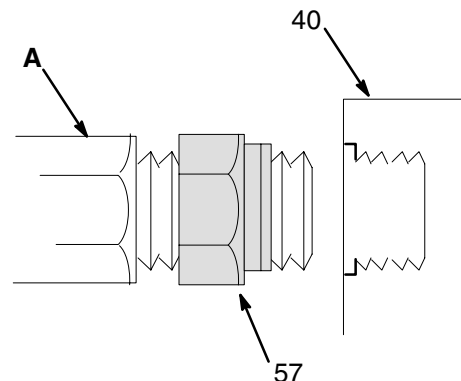

Fig. 1

04467

Installation

Grounding

⚠ WARNING

For your safety, read the **FIRE AND EXPLOSION HAZARD WARNINGS** on page 5, and ground your entire system as instructed below. This section also includes details on how to connect the grounding wire and clamp to the various hydraulic motors.

Proper grounding is an essential part of maintaining a safe system.

To reduce the risk of static sparking, ground the pump. Check your local electrical code for detailed grounding instructions for your area and type of equipment. Be sure to ground all of this equipment:

1. *Pump*: use a ground wire and clamp as shown to the right.
 2. *Hydraulic hoses and fluid outlet hoses*: use only electrically conductive hoses.
 3. *Hydraulic power supply and air compressor*: follow manufacturer's recommendations.
 4. *Spray gun*: obtain grounding through connection to a properly grounded fluid hose and pump.
 5. *Fluid supply container*: according to local code.
 6. *Object being sprayed*: according to local code.
7. *Any pails used when flushing*: Use only metal, grounded pails when flushing. Make firm metal-to-metal contact between the metal part of the spray gun and the pail. Use the lowest possible pressure.
 8. *To maintain grounding continuity when flushing or relieving pressure*, always hold a metal part of the gun firmly to the side of a grounded metal pail, and then trigger the spray gun.

Models 217338, 235345, 262818, and 24W139

Loosen the locknut (A) of the grounding lug and washer. Insert one end of the wire (B) in the grounding lug (61) and tighten the locknut securely. See Fig. 2. Connect the other end of the wire to a true earth ground, as recommended by your local code. Order Part No. 237569, Ground Wire and Clamp.

Model 217022

The ground wire and clamp are supplied with your GH Sprayer. Connect the clamp to a true earth ground as recommended by your local code.

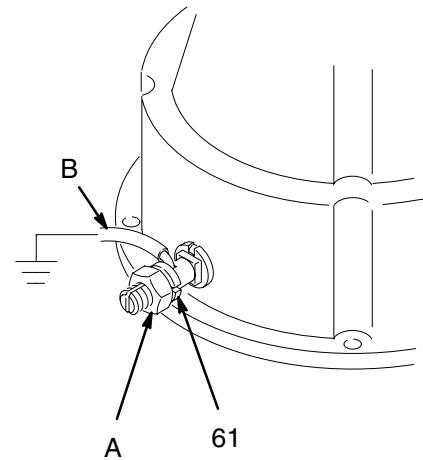

Fig. 2

04468

Service

Pressure Relief Procedure

WARNING



SKIN INJECTION HAZARD

The system pressure must be manually relieved to prevent the system from starting or spraying accidentally. Fluid under high pressure can be injected through the skin and cause serious injury. To reduce the risk of an injury from injection, splashing fluid, or moving parts, follow the **Pressure Relief Procedure** whenever you:

- are instructed to relieve the pressure,
- stop spraying,
- check or service any of the system equipment,
- or install or clean the spray tip.

1. Lock the gun trigger safety.
2. Shut off the hydraulic power supply.
3. Close the supply line shutoff valve, and then the return line shutoff valve.
4. Unlock the gun trigger safety.
5. Hold a metal part of the gun firmly to the side of a grounded metal pail, and trigger the gun to relieve pressure.
6. Lock the gun trigger safety.
7. Open the drain valve (required in your system), having a container ready to catch the drainage.
8. Leave the drain valve open until you are ready to spray again.

If you suspect that the spray tip or hose is completely clogged, or that pressure has not been fully relieved after following the steps above, very slowly loosen the tip guard retaining nut or hose end coupling and relieve pressure gradually, then loosen completely. Now clear the obstruction.

Before you start:

Be sure you have all necessary parts on hand.

1. **Repair Kit 220457** is available for Models 217022 and 217338.

Repair Kit 223654 is available for Models 235345, 262818, and 24W139.

2. The repair kits must be purchased separately. An asterisk behind a reference number in the parts list, for example (25*), indicates that the part is included in the repair kit.
3. Clean all parts as you disassemble them and inspect them for wear or damage. Replace parts as necessary.

Disassembly (Refer to Fig. 3)

NOTE: Use all the replacement parts that are in the repair kit.

1. Flush the displacement pump if possible.

WARNING

To reduce the risk of serious injury whenever you are instructed to relieve pressure, always follow the **Pressure Relief Procedure** on page 8.

2. **Relieve the pressure.**
3. Stop the pump at the bottom of its stroke.

CAUTION

Avoid getting dust or dirt in the motor during service. Cleanliness is essential when repairing an hydraulic motor.

4. Disconnect the displacement pump hoses. Disconnect the hydraulic hoses and plug all hydraulic connections and lines to prevent contamination.

Service

Disassembly (continued – refer to Fig. 3)

CAUTION

When removing the displacement pump, hold it securely. The pump is heavy and could fall off the motor.

5. Disconnect the displacement pump from the motor, as explained in your separate pump manual.
6. Place the hydraulic motor in a bench vise.
7. Push or lightly tap the piston (49) up as far as possible.

NOTE: The tie rod nuts (3), socket screws (8), cap-screws (24), and retainer (32) are fastened with Loctite® TL-242. Heat may be used sparingly to soften adhesive sealant during disassembly.

8. *For Models 217022, 217338, 262818, and 24W139*, loosen, but do not remove, the four tie rod nuts (3) and the nuts (B) on the hydraulic tube (48).

For Model 235345, you need to remove the cap screws (21), the drip pan (26), the drip cover (31), and machine screw (42) *before* loosening the tie rod nuts. Then remove the four tie rod nuts (3). Loosen the nuts (B) on the hydraulic tube (48) and loosen the tie rods (35).

9. Remove the motor from the vise and lay it in a pan.
10. Remove one detent assembly: retaining plug (28), o-ring (25), spring (29), ball guide (27) and ball (7). If the ball or other parts stick in the upper housing (40), turn the motor over and tap lightly. Do not allow the parts to fall into the motor. Repeat the procedure for the other detent assembly.
11. Remove the tie rods (35), but do not remove the crown nuts (22).
12. Remove the socket screws (8) and the end cap (44). Pull the stop plug (43) from the upper housing (40).

13. Unscrew the top and bottom compression nuts (B) on the hydraulic tube (48). Rotate the upper housing (40) and remove the tube, being careful not to damage the flare (A). Allow the oil to drain from the motor into the pan.

CAUTION

With the tie rods removed, the assembly may separate at the joints between the cylinder (39) and the upper and lower housings (40 and 41).

14. Rock the upper housing (40) to work it free and lift it about 3 inches off the cylinder (39). The cylinder can stay in the lower housing (41).
15. Hold the trip rod (36) with an adjustable wrench on the flats of the rod, and remove the top hex nut (20) from the trip rod.
16. Remove the upper housing (40).
17. Remove the trip rod guides (34), compression springs (38) and valve spool (37) from the upper housing. Inspect the bearing inside of the guide (51) in place. If bearing is damaged replace item 51.

NOTE: Inspect the trip rod (36) above the shoulder for damage. There must be no reduction in diameter. Replace if necessary.

18. Pull the trip rod and piston from the lower housing (41) and cylinder (39). Place the piston flats (49) in a vise; tighten the vise *on the flats of the piston*. Use a face spanner to remove the retainer (32). Remove the trip rod (36) from the piston (49).
19. Remove the trip rod locknut (9) and piston stop (33). If the piston is replaced, remove the spring (55) to use in the new piston.
20. *For Models 217022 and 217338*, place the lower housing (41) on top of vice jaws. Pinch the adapter plate (14) in the jaws. Twist and remove. Inspect the bearing (30) and wiper (18) for wear. Replace if necessary.
21. Turn lower housing over and remove the seal (23) and backup seal (23a).
22. *For Models 235345, 262818, and 24W139*, remove the bearing (45), packings (23), and o-ring (12, Model 235345 only).

Service

Model 217022 shown

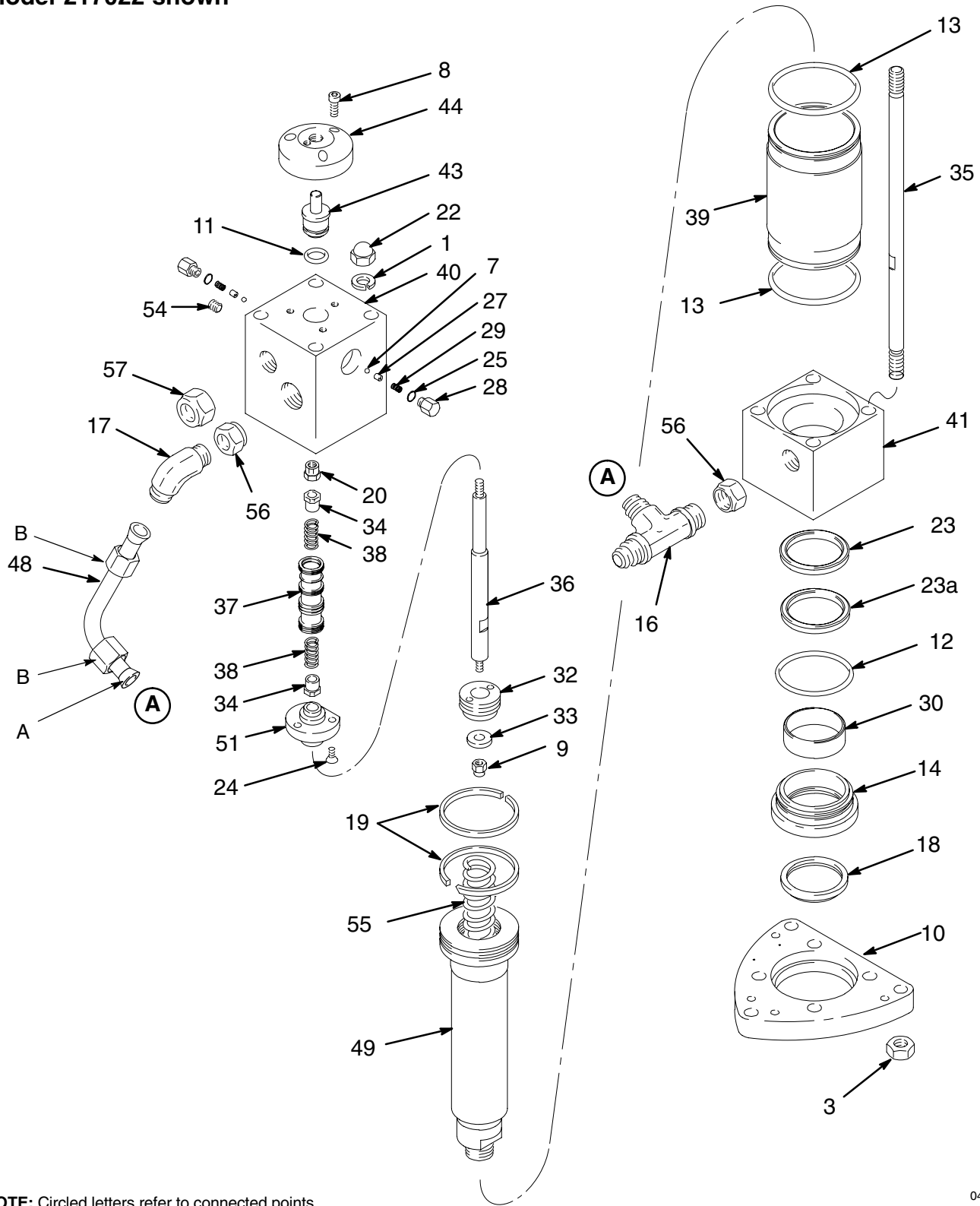

NOTE: Circled letters refer to connected points.

04464

Fig. 3

Service

Reassembly (Refer to Fig. 4)

NOTE: Model 217022 uses one seal (23) and a back-up seal (23a).

1. Lubricate the seal(s) (23) with hydraulic oil. Install them in the lower housing (41) with the *lips facing up toward the top of the motor*.
2. *For Models 217022 and 217338*, install the o-ring (12*) onto the adapter (14). Install the adapter (14) into the lower housing (41), making sure it seats properly. *For Model 235345*, install the o-ring (12) onto the lower housing (41).
3. Place the piston flats in a vise. Install the spring (55) inside the piston (49). The compression rings (19) must be positioned with the joints about 180° opposed. Be sure the o-ring (26) is in place on Model 235345.
4. Install the piston stop (33) and locknut (9) on the trip rod. Torque the nut to 117–123 in-lb (13.2–13.9 N.m). Slide the trip rod (36) into the piston (49). Apply thread sealant to the retainer (32) threads. With the piston flats in a vise, tighten the retainer until it is flush or below the piston surface. This is important to prevent the retainer from backing out during operation and damaging the motor.

NOTE: *For Models 235345, 262818, and 24W139*, set base (2) on workbench during reassembly. *For Models 217022 and 217338*, place adapter (14) in vise jaws and lower housing (41) on top of jaws.

5. Install the o-ring (13) onto the cylinder (39). Install the cylinder (39) into the lower housing (41).
6. Install the trip rod and piston into the cylinder (39) and lower housing (41) so the piston is recessed at least 1 inch (25 mm) from the top of the cylinder.
7. If the bearing and guide (51) was removed, install it on the upper housing (40) with the three screws (24) (apply thread sealant).
8. Hold the flats of the trip rod with an adjustable wrench and install the upper housing (40). The trip rod will protrude from the top.
9. Slide the lower trip rod guide (34) and spring (38) onto the trip rod. Install the spool (37) with the detent at the top. Install the top spring (38) and guide (34) on the trip rod. Install the top hex nut (20). Torque the nut to 82–88 in-lb (9.3–9.9 N.m).

10. Remove the adjustable wrench. Seat the upper housing (40) onto the cylinder (39), so the tube fittings align with those on the lower housing.

Reinstall the hydraulic tube (48) and **loosely** tighten the compression nuts. See the Parts Drawing for your motor.

11. Replace the o-ring (11) on the stop plug (43). Seat the plug into the upper housing (40).
12. Install the end cap (44), using thread sealant on the socket screws (8).
13. Lubricate the threads of the tie rods (35) and install them with lockwashers (1). If the crown nuts (22) were removed, reinstall them and torque them onto the rods to 70–80 ft-lb (95–108 N.m).
14. *For Models 217022, 217338, 262818, and 24W139*, take the motor out of the vise jaws and lay it on its side. Install the lower plate (10).

NOTE: *For Model 217022*, align the point of adapter plate (10) in the same direction as the fluid tube (16).

15. *For Models 217022, 217338 and 262818*, apply thread sealant to the lower threads of the tie rods (35) and torque the tie rod nuts (3) to 70–80 ft-lb (95–108 N.m).

For Model 235345 and 24W139, torque tie rods into base, apply thread sealant, then torque the tie rod nuts (3) to 70–80 ft-lb (95–108 N.m).

16. With the motor on its side, install one detent assembly: the ball (7), guide (27) *with the concave surface toward the ball*, spring (29), o-ring (25*) and retaining plug (28). Torque the plug to 152–158 in-lb (17.2–17.9 N.m). Repeat for the other side of the motor.
17. *For Model 235345*, slide the drip cover (31) onto the piston (49) up to the o-ring (30). Install screw (42) into the piston. Attach the drip pan (26) to the base using screws (21).
18. Snugly tighten the compression nuts on the hydraulic tube (48) and torque to 60–80 ft-lb (81–108 N.m).
19. Install the motor on the displacement pump. Reconnect all fluid lines. Be sure the ground wire is connected before operating the pump.

Service

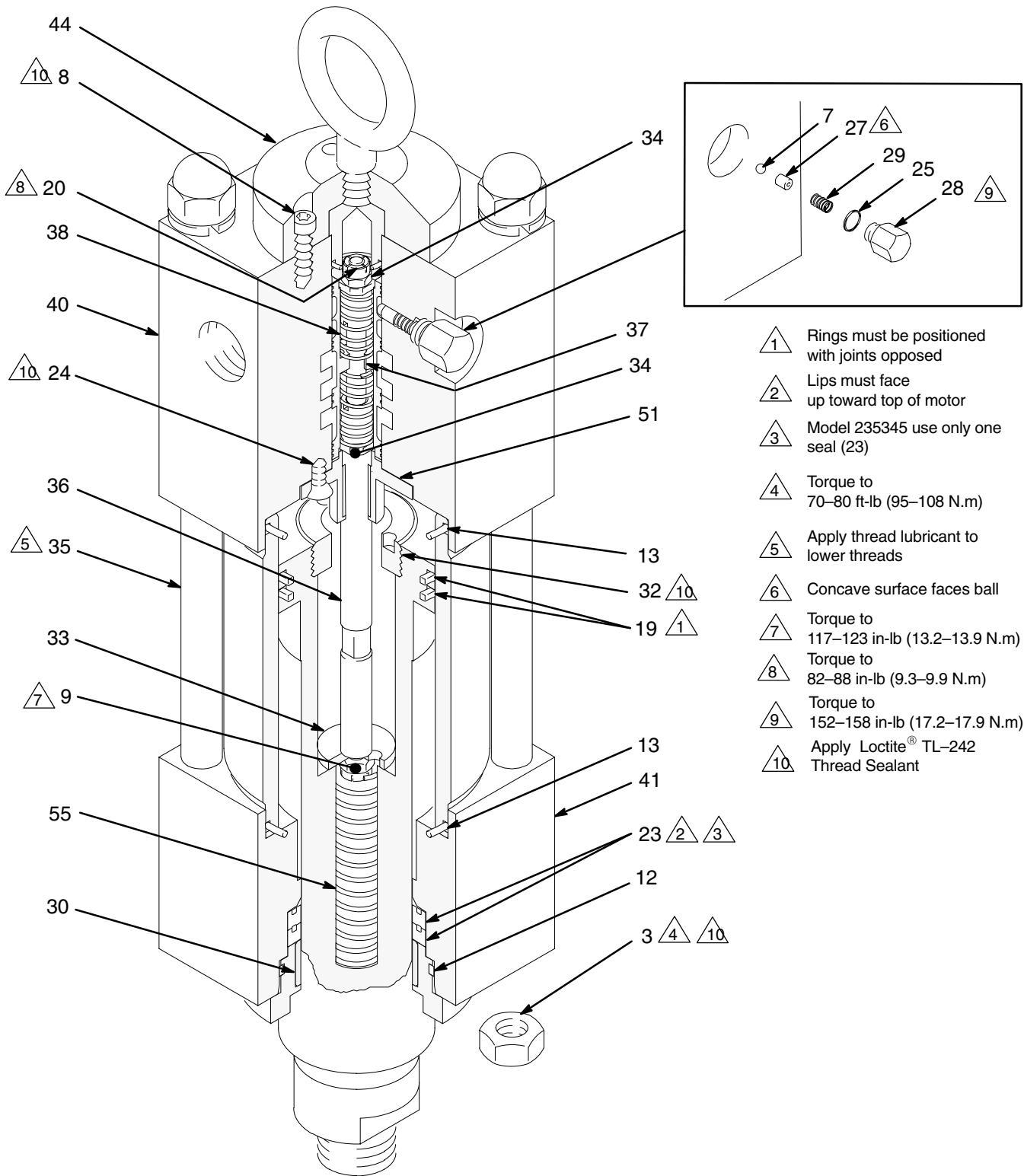











-  Rings must be positioned with joints opposed
-  Lips must face up toward top of motor
-  Model 235345 use only one seal (23)
-  Torque to 70–80 ft-lb (95–108 N.m)
-  Apply thread lubricant to lower threads
-  Concave surface faces ball
-  Torque to 117–123 in-lb (13.2–13.9 N.m)
-  Torque to 82–88 in-lb (9.3–9.9 N.m)
-  Torque to 152–158 in-lb (17.2–17.9 N.m)
-  Apply Loctite® TL-242 Thread Sealant

Fig. 4

04487

Parts

Model 217022, Series D

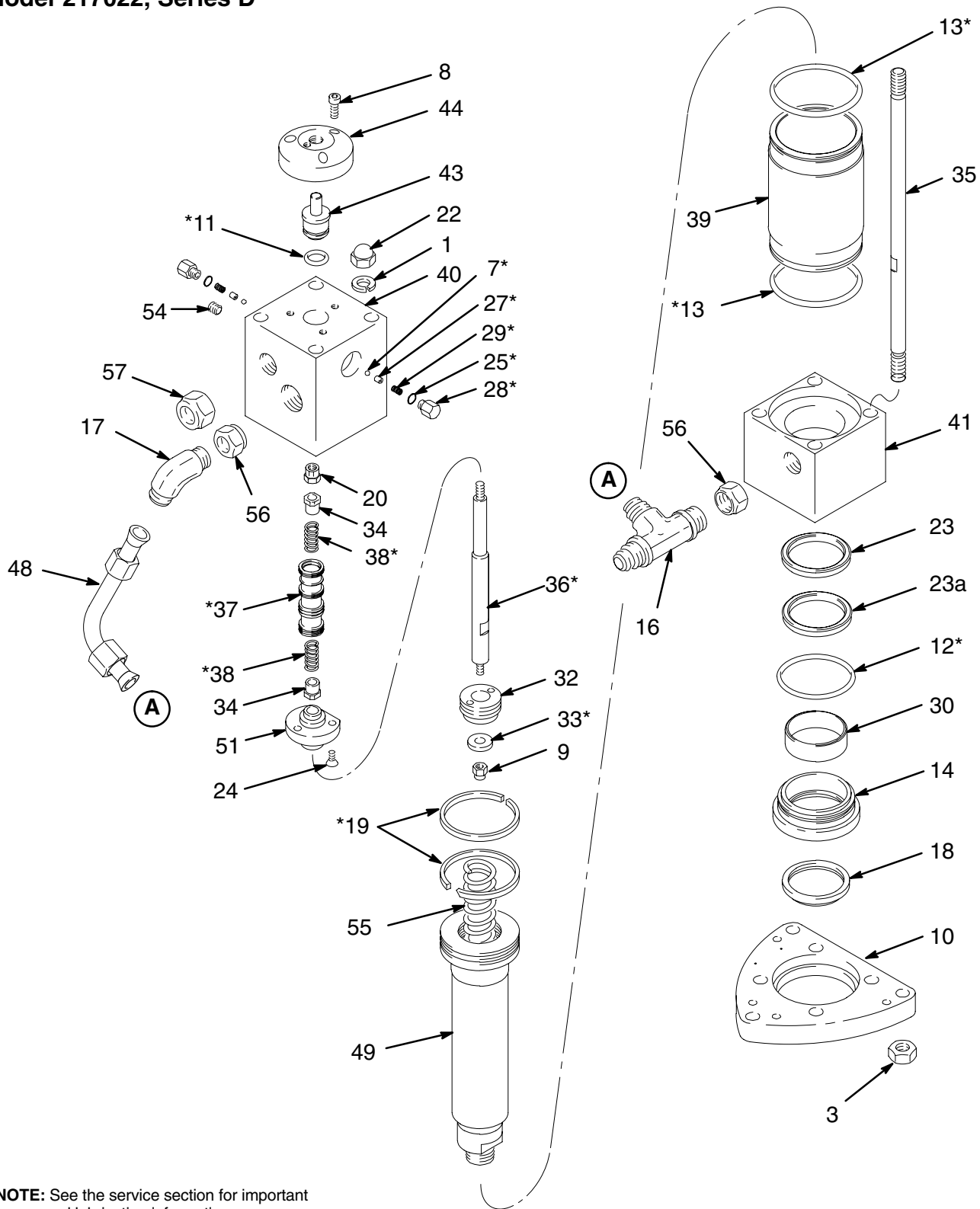

NOTE: See the service section for important torque and lubrication information.

NOTE: Circled letters refer to connected points.

04464

Parts

Model 217022, Series D

Includes items 1–57

Ref. No.	Part No.	Description	Qty.	Ref. No.	Part No.	Description	Qty.
1	100128	LOCKWASHER, spring, 5/8 in.	4	29*	108522	SPRING, helical compression	2
3	102087	NUT, hex jam, 5/8–18	4	30	171395	BEARING, sleeve	1
7*	101701	BALL, 1/4 in. dia.	2	32	171398	RETAINER	1
8	101864	CAPSCREW, soc hd, 5/16–18 x 1 in.	3	33*	181243	STOP, piston	1
9	103450	NUT, hex, self-locking, 5/16–18	1	34	183659	GUIDE, trip rod	2
10	609821	PLATE, tie	1	35	177931	ROD, tie	4
11*	104093	O-RING, nitrile rubber	1	36*	171407	ROD, trip	1
12*	104280	O-RING, nitrile rubber	1	37*	181874	SPOOL, valve	1
13*	104095	O-RING, nitrile rubber	2	38*	171411	SPRING, compression	2
14	609820	ADAPTER, plate	1	39	171412	CYLINDER	1
16	104098	TEE, tube, for 3/4 in. (19 mm) tube	1	40	172814	HOUSING, upper	1
17	104099	ELBOW, 90°, for 3/4 in. (19 mm) tube	1	41	171414	HOUSING, lower	1
18	104102	WIPER	1	43	183252	PLUG, stop	1
19*	104103	RING, piston, compression	2	44	183290	CAP, end	1
20	104105	NUT, hex lock, 1/4–20	1	48	210108	TUBE	1
22	104143	NUT, crown, 5/8–18	4	49	188086	PISTON	1
23	112130	SEAL, v-block, polyurethane	1	51	210292	BEARING and GUIDE	1
23a	112762	SEAL, backup, modular, molythane	1	54	101754	PLUG, pipe, soc hd, 3/8 npt	1
24	108538	SCREW, soc flat hd, self-locking, 1/4–20 x 1/2 in.	3	55	104664	SPRING, compression	1
25*	150111	GASKET, plug	2	56	105429	NUT, seal, 3/4 npt	2
27*	167210	GUIDE, ball	2	57	105430	NUT, seal, 1 in. npt <i>supplied in a plastic bag</i>	1
28*	167431	PLUG, spring retaining	2				

* These parts are also included in Repair Kit 220457, which may be purchased separately.

Parts

Model 217338, Series E

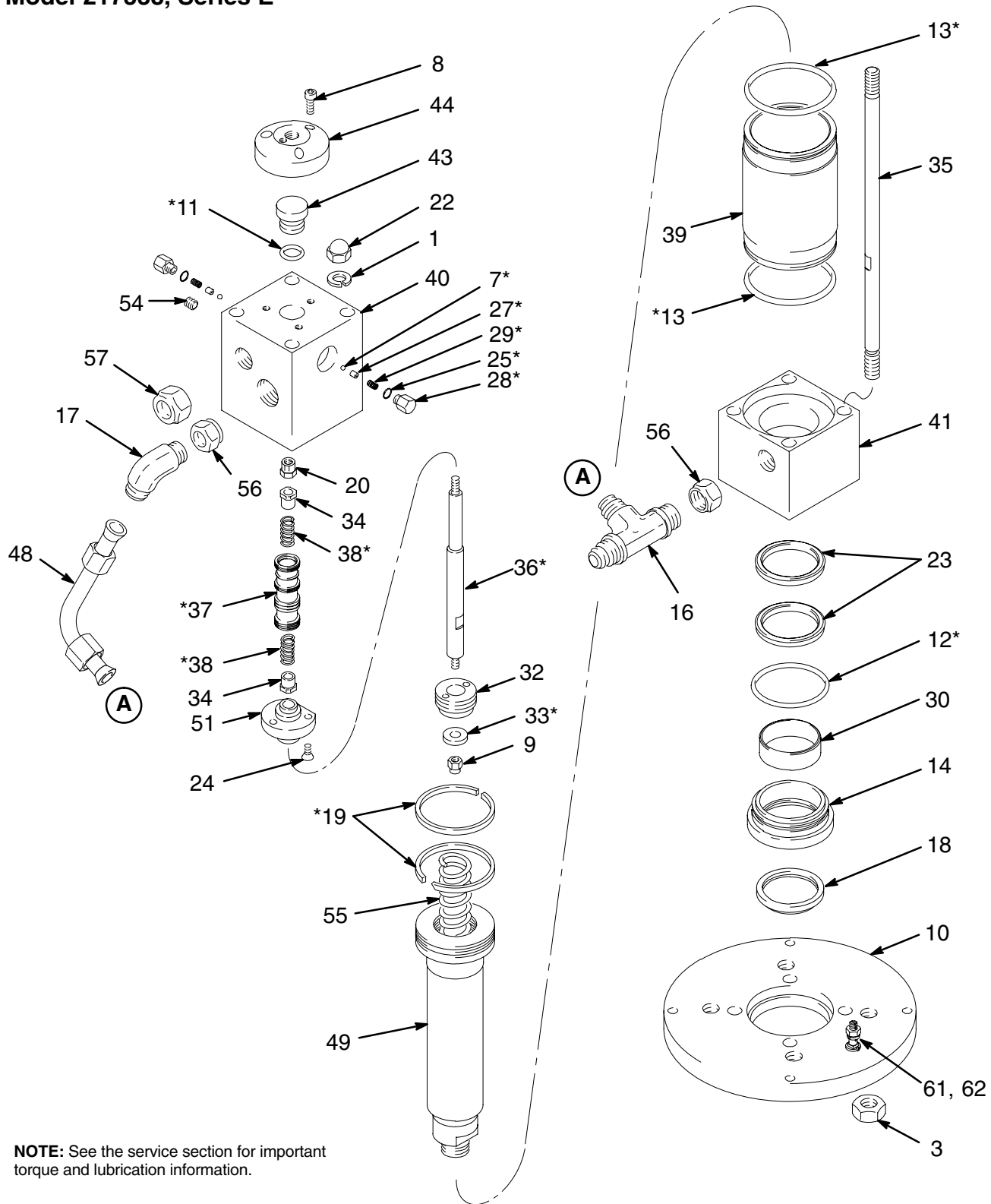

NOTE: See the service section for important torque and lubrication information.

NOTE: Circled letters refer to connected points.

04465

Parts

Model 217338, Series E

Includes items 1–62

Ref. No.	Part No.	Description	Qty.	Ref. No.	Part No.	Description	Qty.
1	100128	LOCKWASHER, spring, 5/8 in.	4	32	171398	RETAINER	1
3	100155	NUT, hex jam, 5/8–18	4	33*	181243	STOP, piston	1
7*	101701	BALL, 1/4 in. dia.	2	34	183659	GUIDE, trip rod	2
8	101864	CAPSCREW, soc hd, 5/16–18 x 1 in.	3	35	171405	ROD, tie	4
9	103450	NUT, hex, self-locking, 5/16–18	1	36*	171407	ROD, trip	1
10	181889	PLATE, tie	1	37*	181874	SPOOL, valve	1
11*	104093	O-RING, nitrile rubber	1	38*	171411	SPRING, compression	2
12*	104280	O-RING, nitrile rubber	1	39	171412	CYLINDER	1
13*	104095	O-RING, nitrile rubber	2	40	172814	HOUSING, upper	1
14	609820	ADAPTER, plate	1	41	171414	HOUSING, lower	1
16	104098	TEE, tube, for 3/4 in. (19 mm) tube	1	43	171416	PLUG, stop	1
17	104099	ELBOW, 90°, for 3/4 in. (19 mm) tube	1	44	180953	CAP, end	1
18	104102	WIPER	1	48	210108	TUBE	1
19*	104103	RING, piston, compression	2	49	188086	PISTON	1
20	104105	NUT, hex lock, 1/4–20	1	51	210292	BEARING and GUIDE	1
22	104143	NUT, crown, 5/8–18	4	54	101754	PLUG, pipe, soc hd, 3/8 npt	1
23	104203	SEAL, v-block, polyurethane	2	55	104664	SPRING, compression	1
24	108538	SCREW, soc flat hd, self locking, 1/4–20 x 1/2 in.	3	56	105429	NUT, seal, 3/4 npt	1
25*	150111	GASKET, plug	2	57	105430	NUT, seal, 1 in. npt <i>supplied in a plastic bag</i>	1
27*	167210	GUIDE, ball	2	61	104029	GROUNDING LUG	1
28*	167431	PLUG, spring retaining	2	62	104582	WASHER	1
29*	108522	SPRING, helical compression	2				
30	171395	BEARING, sleeve	1				

* These parts are also included in Repair Kit 220457, which may be purchased separately.

Parts

Model 235345, Series A

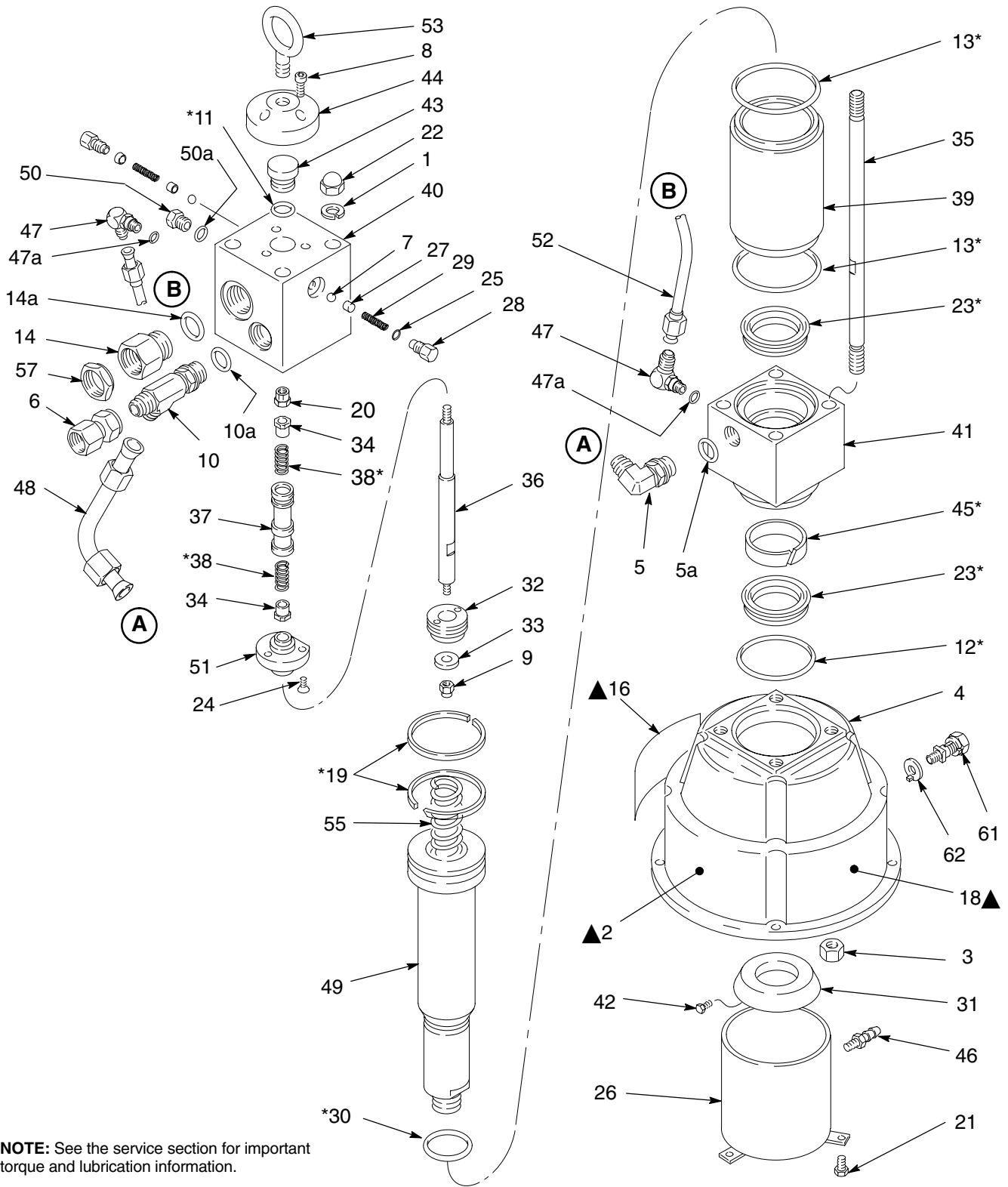

04466

Parts

Model 235345, Series A

Ref. No.	Part No.	Description	Qty.	Ref. No.	Part No.	Description	Qty.
1	100128	LOCKWASHER, spring, 5/8 in.	4	33	181243	STOP, piston	1
2▲	290331	LABEL, instruction, English	1	34	183659	GUIDE, trip rod	2
3	100155	NUT, hex jam, 5/8–18	4	35	171405	ROD, tie	4
4	186221	BASE	1	36	171407	ROD, trip	1
5	110797	ELBOW, male, 3/4 npt <i>Includes item 5a</i>	1	37	181874	SPOOL, valve	1
5a	110926	.O-RING, nitrile rubber	1	38*	171411	SPRING, compression	2
6	112574	ADAPTER, 3/4 npt (f) x 1–1/16–12	1	39	186219	CYLINDER	1
7	101701	BALL, 1/4 in. dia.	2	40	186217	HOUSING, upper	1
8	101864	CAPSCREW, soc hd, 5/16–18 x 1 in.	3	41	186218	HOUSING, lower	1
9	103450	NUT, hex, self-locking, 5/16–18	1	42	101577	SCREW, machine, hex hd; No. 10–20 x 0.375 in.	1
10	110791	TEE, 7/8–14 unf–2a x 1 1/16– 12un–2a, 37° flare for 3/4 in. dia. tube, <i>Includes item 10a</i>	1	43	171416	PLUG, stop	1
10a	110926	.O-RING, nitrile rubber	1	44	180953	CAP, end	1
11*	104093	O-RING, nitrile rubber	1	45*	186223	BEARING, piston, bronze-filled PTFE	1
12*	110800	O-RING, buna–N	1	46	103875	ADAPTER, barbed hose, 1/8 npt x 0.25 in. (6.4 mm) ID hose	1
13*	166071	O-RING, nitrile rubber	2	47	110792	ELBOW, 90°, 7/16–20 unf–2a(m) x 9/16–18 unf–2a(m), 37° flare for 3/8 in. dia. tube, <i>Includes item 47a</i>	2
14	110876	ADAPTER, 1 –11-1/2 npt x 1 5/16–12un–2a, <i>Includes item 14a</i>	1	47a	110801	.O-RING, nitrile rubber	2
14a	110927	.O-RING, nitrile rubber	1	48	210108	TUBE	1
15	177756	LABEL, identification <i>not shown</i>	1	49	188087	PISTON	1
16▲	172975	LABEL, warning	1	50	110799	PLUG, 9/16–18 unf–2b, <i>Includes item 50a</i>	1
17	100508	SCREW, type “u” drive, No. 4 x 0.188 in.	4	50a	110925	.O-RING, nitrile rubber	1
18▲	172815	PLATE, warning	1	51	210292	BEARING and GUIDE	1
19*	104103	RING, piston, compression	2	52	223608	TUBE, drain	1
20	104105	NUT, hex lock, 1/4–20	1	53	108132	RING, lift	1
21	100333	SCREW, cap, hex hd; 1/4–20 x .0.5 in.	3	55	104664	SPRING, compression	1
22	104143	NUT, crown, 5/8–18	4	57	105430	NUT, seal, 1 in. npt <i>supplied in a plastic bag</i>	1
23*	110795	SEAL, u-cup, polyurethane	2	61	104029	GROUNDING LUG	1
24	108538	SCREW, soc flat hd, self locking, 1/4–20 x 1/2 in.	3	62	104582	WASHER	1
25	110801	O-RING, nitrile rubber	2	<p>* <i>These parts are also included in Repair Kit 223654, which may be purchased separately.</i></p> <p>▲ <i>Replacement Danger and Warning labels, tags and cards are available at no cost. Label 290331 is also available in the following languages:</i> <i>German (Part No. 290396)</i> <i>French (Part No. 290397)</i> <i>Spanish (Part No. 290398).</i></p>			
26	210110	PAN, drip	1				
27	167210	GUIDE, ball	2				
28	186222	RETAINER, spring	2				
29*	108522	SPRING, helical compression	2				
30*	165295	O-RING, nitrile rubber	1				
31	171397	COVER, drip	1				
32	171398	RETAINER	1				

Parts

Model 262818, Series A

Model 24W139, Series A

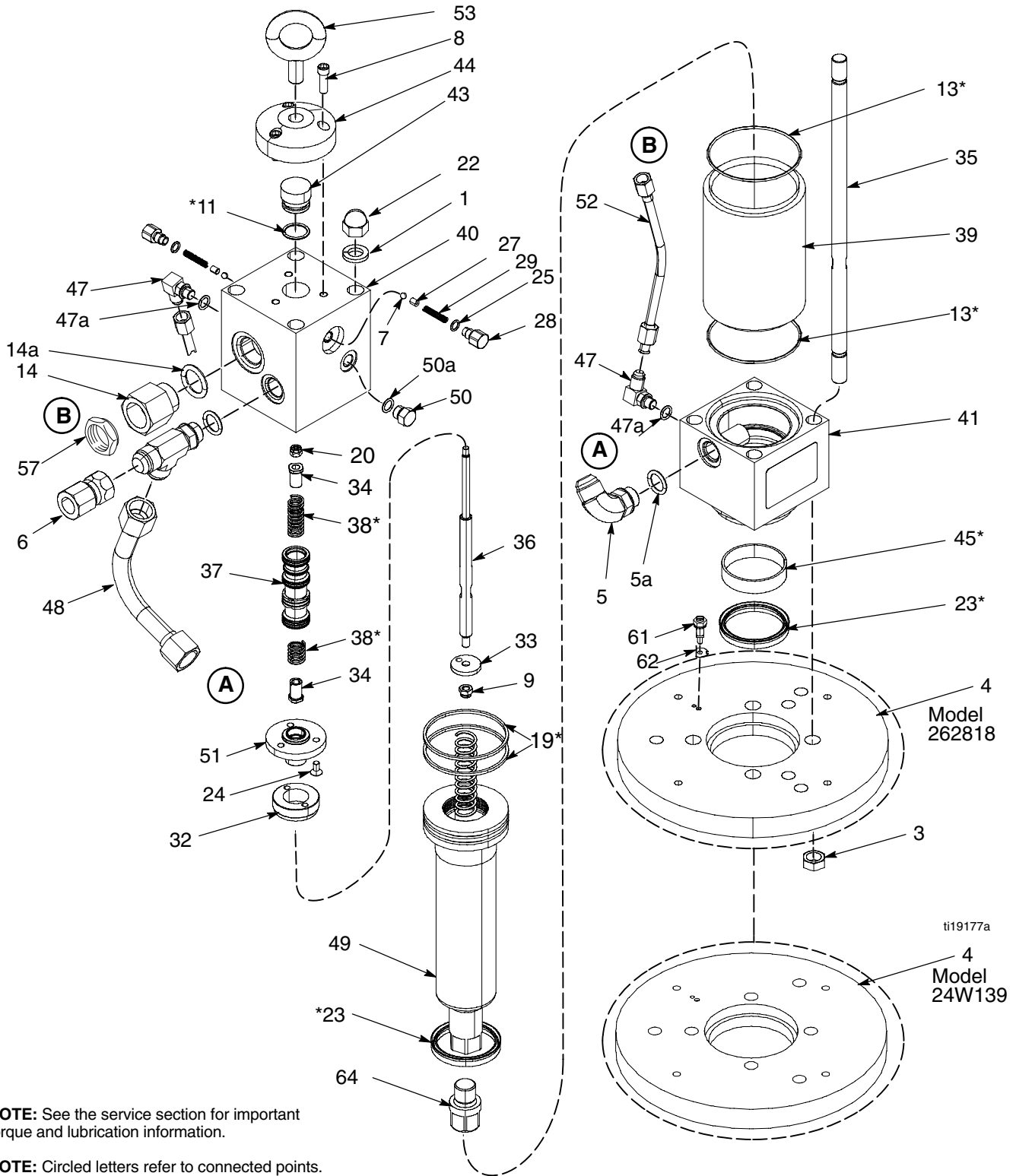

NOTE: See the service section for important torque and lubrication information.

NOTE: Circled letters refer to connected points.

Model 262818, Series A

Model 24W139, Series A

Ref. No.	Part No.	Description	Qty.	Ref. No.	Part No.	Description	Qty.
1	100128	LOCKWASHER, spring, 5/8 in.	4	34	183659	GUIDE, trip rod	2
3	100155	NUT, hex jam, 5/8-18	4	35	171405	ROD, tie	4
4	16M539	PLATE, for Model 262818	1	36	171407	ROD, trip	1
	17B757	PLATE, for Model 24W139		37	181874	SPOOL, valve	1
5	110797	ELBOW, male, 3/4 npt		38*	171411	SPRING, compression	2
		<i>Includes item 5a</i>	1	39	186219	CYLINDER	1
5a	110926	.O-RING, nitrile rubber	1	40	186217	HOUSING, upper	1
6	112574	ADAPTER, 3/4 npt (f) x 1-1/16-12	1	41	186218	HOUSING, lower	1
7	101701	BALL, 1/4 in. dia.	2	43	171416	PLUG, stop	1
8	101864	CAPSCREW, soc hd, 5/16-18 x 1 in.	3	44	180953	CAP, end	1
9	103450	NUT, hex, self-locking, 5/16-18	1	45*	186223	BEARING, piston, bronze-filled PTFE	1
10	110791	TEE, 7/8-14 unf-2a x 1 1/16-12un-2a, 37° flare for 3/4 in. dia. tube, <i>Includes item 10a</i>	1	47	110792	ELBOW, 90°, 7/16-20 unf-2a(m) x 9/16-18 unf-2a(m), 37° flare for 3/8 in. dia. tube, <i>Includes item 47a</i>	2
10a	110926	.O-RING, nitrile rubber	1	47a	110801	.O-RING, nitrile rubber	2
11*	104093	O-RING, nitrile rubber	1	48	210108	TUBE	1
13*	166071	O-RING, nitrile rubber	2	49	16M538	PISTON	1
14	110876	ADAPTER, 1 -11-1/2 npt x 1 5/16-12un-2a, <i>Includes item 14a</i>	1	50	110799	PLUG, 9/16-18 unf-2b, <i>Includes item 50a</i>	1
14a	110927	.O-RING, nitrile rubber	1	50a	110925	.O-RING, nitrile rubber	1
15	177756	LABEL, identification <i>not shown</i>	1	51	210292	BEARING and GUIDE	1
17	100508	SCREW, type "u" drive, No. 4 x 0.188 in.	4	52	223608	TUBE, drain	1
19*	104103	RING, piston, compression	2	53	108132	RING, lift	1
20	104105	NUT, hex lock, 1/4-20	1	55	104664	SPRING, compression	1
22	104143	NUT, crown, 5/8-18	4	57	105430	NUT, seal, 1 in. npt <i>supplied in a plastic bag</i>	1
23*	110795	SEAL, u-cup, polyurethane	2	61	104029	GROUNDING LUG	1
24	108538	SCREW, soc flat hd, self locking, 1/4-20 x 1/2 in.	3	62	104582	WASHER	1
25	110801	O-RING, nitrile rubber	2	64	16M653	ADAPTER, hydraulic motor, Xtreme, 7/8-14 unf-2A x 3/4-16 unf-2B	1
27	167210	GUIDE, ball	2				
28	186222	RETAINER, spring	2				
29*	108522	SPRING, helical compression	2				
32	171398	RETAINER	1				
33	181243	STOP, piston	1				

* *These parts are also included in Repair Kit 223654, which may be purchased separately.*

Mounting Hole Layout

Model 217022

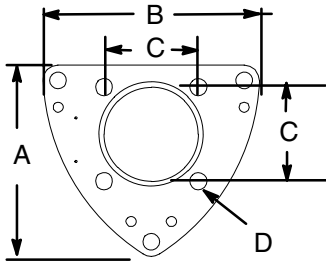

04469

Model 217338

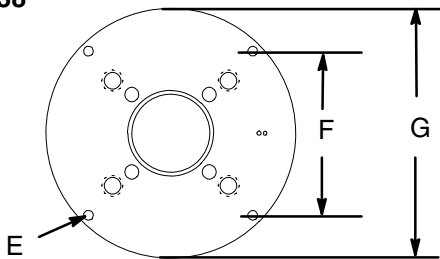

Model 235345

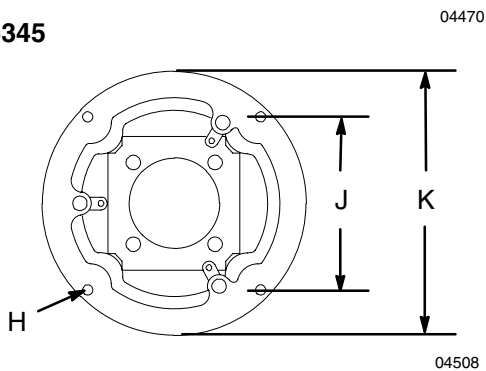

04508

Model 262818 and 24W139

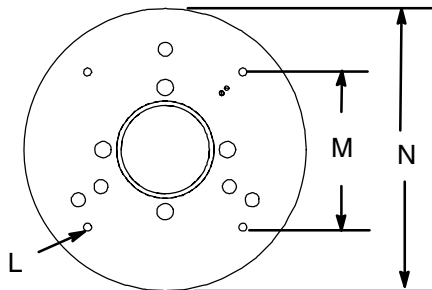

ti19178a

Model 217022			
A	7.2 in. (182.8 mm)	C	3.5 in. (88.9 mm)
B	8.1 in. (205.7 mm)	D	0.641 in. (16.3 mm)
Model 217338			
E	0.438 in. (11.1 mm)	G	11.28 in. (286.5 mm)
F	7.42 in. (188.4 mm)		
Model 235345			
H	0.438 in. (11.1 mm)	K	11.31 in. (287.2 mm)
J	7.42 in. (188.4 mm)		
Models 262818 and 24W139			
L	3/8–16 in.	N	11.25 in. (285.7 mm)
M	6.186 in. (157.1 mm)		

Dimensions

Models 217022, 217338, 24W139 and 262818 (shown)

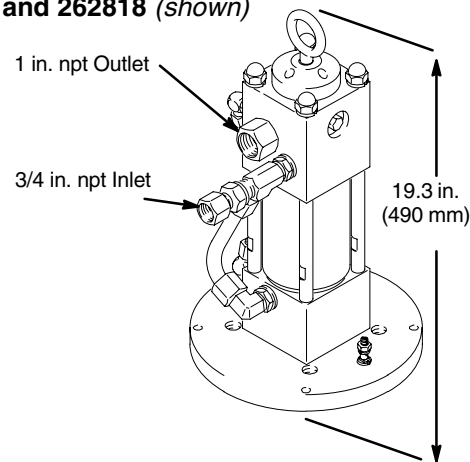

04489

NOTE: Height for Model 235345 is 25.4 in. (645.16 mm).

NOTE: Model 24W139 has a 3/4 in. #12 JIC pump inlet.

Technical Data

Viscount Hydraulic Motor		
	US	Metric
Maximum hydraulic fluid input pressure		
Also see the WARNING on page 6.		
Models 217022, 217338, 235345.	1500 psi	10 MPa, 103 bar
Model 262818	1800 psi	12 MPa, 124 bar
Model 24W139	1900 psi	13.1 MPa, 131 bar
Maximum hydraulic fluid flow	12 gpm	45.6 liter/min
Hydraulic fluid consumption	1 gal. per 5 cycles	3.8 liter per 5 cycles
Effective piston area	4.9 sq. in.	31.6 cm ²
Piston rod diameter	2.5 in.	64 mm
Stroke length	4.69 in.	119.1 mm
Thrust at 1500 psi (10 MPa, 103 bar)	7300 psi	32 472 N
Weight	approximately 96 lb.	43.5 kg

Loctite® is a registered trademark of the Loctite Corp.

Graco Standard Warranty

Graco warrants all equipment listed in this manual which is manufactured by Graco and bearing its name to be free from defects in material and workmanship on the date of sale by an authorized Graco distributor to the original purchaser for use. With the exception of any special extended or limited warranty published by Graco, Graco will, for a period of twelve months from the date of sale, repair or replace any part of the equipment determined by Graco to be defective. This warranty applies only when the equipment is installed, operated and maintained in accordance with Graco's written recommendations.

This warranty does not cover, and Graco shall not be liable for general wear and tear, or any malfunction, damage or wear caused by faulty installation, misapplication, abrasion, corrosion, inadequate or improper maintenance, negligence, accident, tampering, or substitution of non-Graco component parts. Nor shall Graco be liable for malfunction, damage or wear caused by the incompatibility of Graco equipment with structures, accessories, equipment or materials not supplied by Graco, or the improper design, manufacture, installation, operation or maintenance of structures, accessories, equipment or materials not supplied by Graco.

This warranty is conditioned upon the prepaid return of the equipment claimed to be defective to an authorized Graco distributor for verification of the claimed defect. If the claimed defect is verified, Graco will repair or replace free of charge any defective parts. The equipment will be returned to the original purchaser transportation prepaid. If inspection of the equipment does not disclose any defect in material or workmanship, repairs will be made at a reasonable charge, which charges may include the costs of parts, labor, and transportation.

Graco's sole obligation and buyer's sole remedy for any breach of warranty shall be as set forth above. The buyer agrees that no other remedy (including, but not limited to, incidental or consequential damages for lost profits, lost sales, injury to person or property, or any other incidental or consequential loss) shall be available. Any action for breach of warranty must be brought within two (2) years of the date of sale.

GRACO MAKES NO WARRANTY, AND DISCLAIMS ALL IMPLIED WARRANTIES OF MERCHANTABILITY AND FITNESS FOR A PARTICULAR PURPOSE IN CONNECTION WITH ACCESSORIES, EQUIPMENT, MATERIALS OR COMPONENTS SOLD BUT NOT MANUFACTURED BY GRACO. These items sold, but not manufactured by Graco (such as electric motors, gas engines, switches, hose, etc.), are subject to the warranty, if any, of their manufacturer. Graco will provide purchaser with reasonable assistance in making any claim for breach of these warranties.

In no event will Graco be liable for indirect, incidental, special or consequential damages resulting from Graco supplying equipment hereunder, or the furnishing, performance, or use of any products or other goods sold hereto, whether due to a breach of contract, breach of warranty, the negligence of Graco, or otherwise.

FOR GRACO CANADA CUSTOMERS

The parties acknowledge that they have required that the present document, as well as all documents, notices and legal proceedings entered into, given or instituted pursuant hereto or relating directly or indirectly hereto, be drawn up in English. Les parties reconnaissent avoir convenu que la rédaction du présente document sera en Anglais, ainsi que tous documents, avis et procédures judiciaires exécutés, donnés ou intentés à la suite de ou en rapport, directement ou indirectement, avec les procédures concernées.

Graco Information

TO PLACE AN ORDER, contact your Graco distributor, or call one of the following numbers to identify the distributor closest to you:

1-800-328-0211 Toll Free

612-623-6921

612-378-3505 Fax

All written and visual data contained in this document reflects the latest product information available at the time of publication. Graco reserves the right to make changes at any time without notice.

For patent information, see www.graco.com/patents.

Original instructions. This manual contains English. MM 307158

Graco Headquarters: Minneapolis

International Offices: Belgium, China, Japan, Korea

GRACO INC. AND SUBSIDIARIES • P.O. BOX 1441 • MINNEAPOLIS MN 55440-1441 • USA
Copyright 1974, Graco Inc. All Graco manufacturing locations are registered to ISO 9001.

www.graco.com

Revision ZAF, December 2014

Free Manuals Download Website

<http://myh66.com>

<http://usermanuals.us>

<http://www.somanuals.com>

<http://www.4manuals.cc>

<http://www.manual-lib.com>

<http://www.404manual.com>

<http://www.luxmanual.com>

<http://aubethermostatmanual.com>

Golf course search by state

<http://golfingnear.com>

Email search by domain

<http://emailbydomain.com>

Auto manuals search

<http://auto.somanuals.com>

TV manuals search

<http://tv.somanuals.com>