



Promaster 310 Grass Catcher

Owner/Operator & Parts Manual

Model
890015*

*NOTE: Installation requires a separate mower boot kit,
p/n 04916000 for 60" decks, p/n 04916100 for 50" decks.

08493200A 12/03
Supercedes 08493200
Printed in USA

TABLE OF CONTENTS

| | | | |
|-------------------|---|-----------------------|----|
| Safety | 3 | Storage | 9 |
| Assembly | 6 | Troubleshooting | 9 |
| Operation | 7 | Parts List | 10 |
| Maintenance | 8 | Warranty | 13 |

INTRODUCTION

THE MANUAL

Before operation of unit, carefully and completely read your manuals. The contents will provide you with an understanding of safety instructions and controls during normal operation and maintenance.

All reference to left, right, front, or rear are given from operator sitting in operation position and facing the direction of forward travel.

MODEL AND SERIAL NUMBERS

Transfer model & serial number label from product registration here.

When ordering replacement parts or making service inquiries, know the Model and Serial numbers of your unit.

Numbers are located on the product registration form in the unit literature package. They are printed on a serial number label, located on the frame of your unit.

- Record Unit Model and Serial numbers here.

UNAUTHORIZED REPLACEMENT PARTS

Use only Gravelly replacement parts. The replacement of any part on this vehicle with anything other than an Gravelly authorized replacement part may adversely affect the performance, durability, or safety of this unit and may void the warranty. Gravelly disclaims liability for any claims or damages, whether warranty, property damage, personal injury or death arising out of the use of unauthorized replacement parts.

PRODUCT REGISTRATION

The Gravelly dealer must register the product at the time of purchase. Registering the product will help the company process warranty claims or contact you with the latest service information. All claims meeting requirements during the limited warranty period will be honored, whether or not the product registration card is returned. Keep a proof of purchase if you do not register your unit.

Customer Note: If Dealer does not register your product, please fill out, sign and return the product registration card to Gravelly.

DISCLAIMER

Ariens reserves the right to discontinue, make changes to, and add improvements upon its products at any time without public notice or obligation. The descriptions and specifications contained in this manual were in effect at printing. Equipment described within this manual may be optional. Some illustrations may not be applicable to your unit.

DELIVERY

Customer Note: If you have purchased this product without complete assembly and instruction by your retailer, it is your responsibility to:

1. Read and understand all assembly instructions in this manual. If you do not understand or have difficulty following the instructions, contact your nearest Gravelly Dealer for assistance. Make sure all assembly has been properly completed and safety interlock system works properly.

NOTE: To locate your nearest Gravelly Dealer, call 800-472-8359 or go to www.gravelly.com on the internet.



WARNING: Improper assembly or adjustments can cause serious injury.

2. Understand all Safety Precautions provided in the manuals.
3. Review control functions and operation of the unit. Do not operate unit unless all controls function as described in this manual.
4. Review recommended lubrication, maintenance and adjustments.
5. Fill out Original Purchaser Registration Card and return the card to Gravelly Company.

SAFETY

SAFETY ALERTS



Look for these symbols to point out important safety precautions. They mean:

Attention!



Personal Safety Is Involved!

Become Alert!

Obey The Message!

The safety alert symbols above and signal words below are used on decals and in this manual.

Read and understand all safety messages.



DANGER: IMMINENTLY HAZARDOUS SITUATION! If not avoided, WILL RESULT in death or serious injury.



WARNING: POTENTIALLY HAZARDOUS SITUATION! If not avoided, COULD RESULT in death or serious injury.



CAUTION: POTENTIALLY HAZARDOUS SITUATION! If not avoided, MAY RESULT in minor or moderate injury. It may also be used to alert against unsafe practices.

NOTATIONS

NOTE: General reference information for proper operation and maintenance practices.

IMPORTANT: Specific procedures or information required to prevent damage to unit or attachment.

PRACTICES AND LAWS

Practice usual and customary safe working precautions, for the benefit of yourself and others. Understand and follow all safety messages. Be alert to unsafe conditions and the possibility of minor, moderate, or serious injury or death. Learn applicable rules and laws in your area. Always follow the practices set forth in this manual.

REQUIRED OPERATOR TRAINING

Original purchaser of this unit was instructed by the seller on safe and proper operation by the seller. If unit is to be used by someone other than original purchaser; loaned, rented or sold, ALWAYS provide this manual and any needed safety training before operation.

SAFETY DECALS AND LOCATIONS

ALWAYS replace missing or damaged Safety Decals. Refer to Parts List for Safety Decal locations.

Danger! - To Avoid Serious Injury



OL0900

ROTATING FAN! Stop grass pump and power unit engines before removing any part of bagger. Wait for all moving parts to stop.



OL0910

DO NOT operate mower unless guards are in place or grass pump and entire bagger are attached.

Stop engines and wait for all moving parts to stop before opening cover.



OL4140

Keep children and others away from unit while operating.



OL4690

ALWAYS wear adequate hearing protection.

Avoid tip over and loss of control:

DO NOT overload bagger.

Use extreme caution on slopes.

DO NOT make abrupt turns or speed changes.

Be aware of new turning radius.

Caution - Grass Catcher

Stop engine or motor before attaching or removing grass catcher. Under normal use the catcher bag material is subject to wear and deterioration and should be checked to insure compliance with original manufacturer specifications.

Boot Danger - Rotating Blades



OL5000

Keep feet and hands clear.

Boot Caution - Rotating Blades

Stop engine before removing or cleaning this chute. Keep hands and feet clear! Rotating blades!

Warning - Engine

DO NOT operate in poorly ventilated area.

DO NOT refuel while engine is running. Make sure no flame/spark around during refuel.

DO NOT touch exhaust system and engine while hot.

DO NOT touch spark plug cap or high tension cord during engine running.

*SEE YOUR OPERATOR'S MANUAL.

ASSEMBLY SAFETY RULES

Read, understand, and follow all safety practices in Owner/Operator Manual before beginning assembly. Failure to follow instructions could result in personal injury and/or damage to unit.

ALWAYS remove key and wire from spark plugs on unit before assembly. Unintentional engine start up can cause death or serious injury.

Sharp edges can cut. Movement of parts can cut off fingers or a hand. Wrap blade(s), wear sturdy gloves and use extreme caution when working near blades.

Installing the grass catcher on your mower requires the removal of the discharge chute deflector. Retain discharge chute and hardware in a safe location and reinstall whenever operating unit without the grass pump. DO NOT operate mower unless guards are in place or grass pump and entire bagger are attached.

OPERATIONAL SAFETY RULES

Walk Around Inspection

Complete a walk around inspection of unit and work area to understand:

- Work area
- Your unit
- All safety decals

Work Area

ALWAYS check overhead and side clearances carefully before operation. ALWAYS be aware of traffic when operating along streets or curbs.

Keep children and people away. Keep children out of work area and under watchful care of a responsible adult.

NEVER allow children to operate or play on or near unit. Be alert and shut off unit if children enter area.

Keep area of operation clear of all toys, pets, and debris. Thrown objects can cause injury.

Check for weak spots on docks, ramps or floors. Avoid uneven work areas and rough terrain. Stay alert for hidden hazards.

Avoid uneven and rough terrain. DO NOT operate near drop offs, ditches, or embankments. Unit can suddenly turn over if a wheel is over the edge of a cliff or ditch, or if an edge caves in.

Dust, fog, etc. can reduce vision and cause an accident. Operate unit only when there is good visibility and light.

Personal Safety

Only trained adults may operate unit.

Training includes actual operation.

NEVER operate unit after or during the use of medication, drugs or alcohol. Safe operation requires your complete and unimpaired attention at all times.

NEVER allow anyone to operate this unit when their alertness or coordination is impaired.

Wear adequate safety gear and protective gloves.

Wear proper footwear to improve footing on slippery surfaces.

DO NOT wear loose clothing or jewelry and tie back hair that may get caught in rotating parts.

Protect eyes, face and head from objects that may be thrown from unit. Wear appropriate hearing protection.

Avoid sharp edges. Sharp edges can cut. Moving parts can cut off fingers or a hand.

ALWAYS keep hands and feet away from all rotating parts during operation. Rotating parts can cut off body parts.

NEVER place your hands or any part of your body or clothing inside or near any moving part while unit is running.

ALWAYS disengage attachment, stop unit and engine, remove key and allow moving parts to stop before leaving operator's position.

Operation

Understand:

- How to operate all controls
- The functions of all controls
- How to STOP in an Emergency
- Braking and steering characteristics
- Turning radius and clearances

NEVER operate bagger if the tractor's safety interlock system is not working properly.

Always be aware of maximum sweep of catcher when turning. Always allow adequate clearance between catcher, personnel and other objects when turning.

As grass catcher fills, be alert to changing unit stability and control.

Disengage PTO when attachment is not in use.

ALWAYS disengage PTO, stop unit and engine, remove key, engage parking brake and allow moving parts to stop before leaving operator's position.

DO NOT operate at too fast a rate. DO NOT change engine governor settings or over-speed engine. Slow down before turning.

DO NOT mow near dropoffs, ditches or embankments. The mower could suddenly turn over if a wheel is over the edge of a cliff or ditch, or if an edge caves in.

DO NOT mow on wet grass. Reduced traction could cause sliding.

DO NOT try to stabilize the machine by putting your foot on the ground.

Know the weight of loads. Limit loads to those you can safely control and the unit can safely handle.

ALWAYS keep protective structures, guards and panels in good repair, in place and securely fastened.

DO NOT operate in reverse unless absolutely necessary. ALWAYS look down and behind before and while backing.

Watch for holes, ruts, or bumps. Uneven terrain could overturn the machine.

ALWAYS allow adequate clearance for unit, attachments, operator and objects in work area when turning. Slow down before turning.

NEVER carry passengers.

Hazardous Slopes

If you cannot back up a slope or you feel uneasy on it, do not mow it.

Mow up and down slopes, not across them.

Keep all movements on the slope *slow* and *gradual*. DO NOT make sudden changes in speed or direction.

Avoid starting or stopping on a slope. If tires lose traction, disengage the blades and proceed slowly *straight* down the slope.

DO NOT operate on slopes over 10°.

DO NOT park on slopes unless absolutely necessary. If you must park on a slope, always chock or block wheels. Always set parking brake.

Transport

Use extra care when loading or unloading unit onto trailer or truck.

Secure unit chassis to transport vehicle. NEVER secure from rods or linkages that could be damaged.

DO NOT transport machine while engine is running.

ALWAYS turn off power to attachment when transporting.

MAINTENANCE AND SERVICE SAFETY RULES

Disengage PTO, stop engine, remove key and wait for all moving parts to stop before servicing, making repairs, adjusting or when clearing debris.

ALWAYS block wheels. Know all jack stands are strong, secure and will hold weight of unit during maintenance.

ALWAYS keep protective structures, guards, and panels in good repair, in place and securely fastened. NEVER modify or remove safety devices.

Fumes from engine exhaust can cause injury or death. DO NOT run engine in an enclosed area. Always provide good ventilation.

Keep unit free of grass, leaves, or other debris. Clean up oil or fuel spills.

Check grass can and catcher parts prior to each use for any holes, abrasions, mildew, or structural damage. Replace parts when necessary.

Keep all hardware properly tightened.

Cleaning

Keep unit free of debris. Clean up oil or fuel spills.

STORAGE SAFETY RULES

DO NOT store grass can with grass in them.

For extended storage, clean unit thoroughly. See Engine Manual for proper storage.

ALWAYS lower cutting deck when unit is parked or stored.

FUEL SAFETY RULES

Fuel is highly flammable and its vapors are explosive. Handle with care. Use an approved fuel container.

NO smoking, NO sparks, NO flames. ALWAYS allow engine to cool before servicing.

NEVER fill fuel tank when engine is running or hot from operation.

NEVER fill or drain fuel tank indoors.

Replace fuel cap securely and clean up spilled fuel.

ACCESSORY AND ATTACHMENT SAFETY RULES

Use only attachments or accessories designed for your unit and properly installed.

Check attachment components frequently. If worn or damaged, replace with manufacturer's recommended parts.

Grass catcher components are subject to wear, damage, and deterioration, which could expose moving parts or allow objects to be thrown. Frequently check components and replace with manufacturer's recommended parts, when necessary.

ASSEMBLY



WARNING: AVOID INJURY. Read and understand *Assembly Safety Rules* in *Safety* section before attempting to assemble unit.

Unpacking Unit

IMPORTANT: Remove contents from carton carefully. Place cover assembly on a flat piece of cardboard to avoid scratching it.

Tools Required

- Wrenches: 1/2", 9/16", 3/4", 15/16"
- Drill: 11/16"

ASSEMBLY

Refer to Parts section for illustrations and parts locations.

NOTE: Installation requires a separate mower boot kit, p/n 04916000 for 60" decks, p/n 04916100 for 50" decks.

NOTE: For units before serial number 500, drill two 11/16" diameter holes in the right side frame as shown in Figure 1. It may be necessary to cut an access hole in the side of the footrest to mark and drill the rear hole.

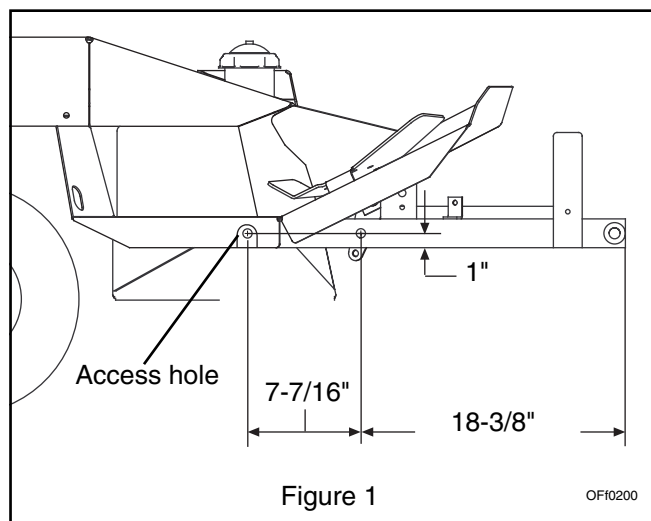

Assemble Grass Catcher Weldment

1. Attach bagger adapter plate (item #52) to right side of unit frame.
2. Attach catcher mount weldment (item #45) to bagger adapter plate.
3. Fasten tube bracket (item #32) and pivot bracket weldment (item #34) to upright. Do not tighten hardware yet.
4. Slip a clamp over each end of catcher tube (item #5). Put one end over blower (item #23) outlet flange and the other end onto the tube bracket. Tighten the bottom clamp.

5. Fasten catcher tube to the tube bracket. Use the two holes nearest the tube end.
6. Fasten ring weldment (item #35) to the pivot bracket weldment. With the ring in the raised position, place the grass can on the catcher weldment (item #50). Lower the ring onto the grass can. Tighten the hardware installed in step 3 above.
7. Connect the catcher tube to the inlet on the grass catcher cover (item #29). Raise the ring and pull the cover inside the ring. Fold the edge of the cover around the ring and secure with the snaps on the cover.



CAUTION: When emptying grass can, always remove hold down strap from ring weldment.

8. Put one end of the hold down strap (item #36) through the hole on the catcher weldment. Bend the S-hook so it cannot snap out of the hole. Hook the other end of the hold down strap through the tab on the ring weldment.
9. Put the hose adapter (item #19) in place at the blower inlet and retain with two locking handles (item #20).

Install Mower Boot



WARNING: Never operate mower without discharge chute deflector or complete grass catcher installed.

1. Remove discharge chute deflector from mower deck. **Keep discharge chute and hardware to reinstall when bagger gets removed.**
2. Fasten boot bracket to mower boot.
3. Place the mower boot over the discharge opening and fasten to deck with boot bracket.

Connect Bagger to Unit

1. Connect catcher weldment to catcher mount with klik pins (item #44).
2. Connect the blower hose (item #59) to the blower inlet and secure with clamp.
3. Connect the blower hose to the mower boot and secure with clamp.



CAUTION: Deflected material may cause injury. **ALWAYS** operate mower with bagger cover closed and secured with hold down strap, grass pump assembly fastened securely or with discharge chute deflector in operating position.

REMOVING BAGGER

1. Disconnect hose from blower inlet and mower boot.
2. Remove klik pins from catcher weldment and remove catcher from unit.

3. Remove mower boot from deck.
4. Replace original discharge chute deflector.

OPERATION



WARNING: AVOID INJURY. Read and understand *Operational Safety Rules* in *Safety* section before operating.

Throttle Lever

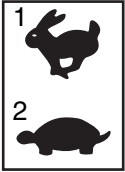

OE0340

Move lever to FAST (1) position to increase engine speed. Move lever to SLOW (2) position to decrease engine speed.

NOTE: An automatic clutch controls grass pump fan engagement and speed. Increasing engine speed engages the clutch and increases fan speed.

Choke



OE0590

Pull choke control out to start a cold engine. Push control in as engine warms up.

Engine Switch

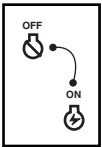

Turn switch to On to start engine.
Turn switch to Off to shut-off engine.

Recoil Starter Handle

When pulled, handle will crank engine.

IMPORTANT: DO NOT let handle snap back against unit.

BEFORE EACH USE

1. Check catcher parts for wear, deterioration or damage. Replace **ONLY** with Gravely original service parts before operating.
2. Ensure all hardware is tight.
3. Remove any grass build up from catcher parts.
4. Ensure hoses are secure to mower boot, grass blower and catcher.
5. Place cover on grass can, close and secure cover with hold down strap.

TO STOP IN AN EMERGENCY

Turn unit ignition key to OFF.

Turn grass catcher engine switch to OFF.

BAGGING

Starting

IMPORTANT: ALWAYS start grass catcher engine before starting unit engine.

1. Start grass catcher engine per engine manual instructions.
2. Set grass catcher engine throttle to fastest speed.

NOTE: An automatic clutch controls grass pump fan engagement and speed. Increasing engine speed engages the clutch and increases fan speed.

3. Start unit engine and engage PTO according to unit owner's manual.
4. Set unit throttle to fastest speed.
5. Choose a slow ground speed.

Shut Off

1. Disengage PTO.
2. Shut off unit according to unit owner's manual.
3. Shut off grass catcher engine and wait for all moving parts to stop.

EMPTYING GRASS CAN

If catcher stops picking up grass clippings, grass can may be full.

To empty grass can:

1. Disengage PTO, stop unit engine and remove ignition key. Wait for all moving parts to stop before leaving operator's position.
2. Stop grass catcher engine. Wait for all moving parts to stop before touching catcher parts.



CAUTION: When emptying grass can, always remove hold down strap from ring weldment.

3. Remove cover.
4. Remove grass can from catcher weldment.
5. Empty grass can.
6. Replace can on catcher weldment.
7. Close cover and secure can with hold down strap.

UNCLOGGING GRASS CATCHER



WARNING: MOVING PARTS can cut or amputate body parts.

NEVER attempt to clear grass pump while engine is running.

ALWAYS stop unit and grass catcher engines, remove key, and wait for moving parts to stop.

Sharp edges can cut. Moving parts can cut off fingers or a hand. Wrap blade(s), wear sturdy gloves and use extreme caution when working near blades or impeller.



WARNING: PINCH POINT! Use extreme caution when unclogging grass blower. Impeller can cut or pinch your hand, even when not in operation. Wear sturdy gloves when working near impeller.

If hose or grass blower gets clogged, stop forward motion and allow unit to clear itself. If unit will not clear itself, unclog the hose/grass blower manually as instructed below.

To unclog:

1. Stop unit engine and remove ignition key. Wait for all moving parts to stop.

Stop grass catcher engine, wait for all moving parts to stop and disconnect spark plug wire.

2. Loosen hose clamp on hose.
3. Remove hose from grass blower.

If clog is in hose:

1. Remove clogged grass.
2. Reinstall hose and tighten hose clamp.

If clog is in grass blower:



WARNING: Impeller blades can cut or amputate fingers or hands. Block impeller blades to prevent rotation before proceeding.

1. Remove hose adapter.
2. Clear grass from blower.
3. Reinstall hose adapter and hose and tighten hose clamp.

OPERATING TIPS

- Cut grass when it is dry.
- Cut grass in two passes when cutting thick, long or wet grass. Make the first cut higher than desired. Make the second cut at desired height.
- Always use full throttle when bagging.
- Clean deck after each use to reduce clogging.

MAINTENANCE

Gravelly Dealers will provide any service or adjustments which may be required to keep your unit operating at peak efficiency.



WARNING: AVOID INJURY. Read and understand *Maintenance and Service* in *Safety* section before attempting any maintenance.

MAINTENANCE SCHEDULE

The chart below shows the recommended maintenance schedule that should be performed on a regular basis.

MAINTENANCE SCHEDULE

| Service Performed | Each Use | Every 10 hrs. |
|----------------------|----------|---------------|
| Check Fasteners | • | |
| Inspect Bagger Parts | • | |
| Clean Unit | • | |
| Check Engine Oil | • | |
| Change Engine Oil | | * |
| Check Belt | | • |
| Lubricate Unit | | • |
| Check Spark Plug | | ** |

* Change engine oil according to manufacturer's recommendations. See engine manual for specific instructions.

** See engine manual for schedule and specific instructions.

CHECK FASTENERS

Be certain that all hardware is tight before each use. Pay special attention to the guards and safety shields.

INSPECT CATCHER PARTS

Before each use, inspect grass catcher parts for any holes, abrasions, or structural damage. Replace any worn or damaged parts.

CLEAN UNIT

Clear away grass build up in catcher before and after each use.

CHECK ENGINE OIL

Check engine oil before each use. See engine manual for instructions.

CHANGE ENGINE OIL

See engine manual for oil change schedule and instructions.

CHECK BELT

Check belt for wear and proper tension every 10 hours. Replace belt if worn or deteriorated.

To replace:

1. Remove belt guard.
2. Loosen four bolts and lock nuts holding blower to catcher weldment.
3. Loosen 3/8" jam nut.
4. Place new belt on grass pump drive pulley, idler and deck pulley.

5. Adjust tension.
6. Replace belt guard.

To adjust tension:

1. Remove belt guard.
2. Loosen hardware securing bagger engine to weldment.
3. Loosen four bolts and lock nuts holding blower to catcher weldment.
4. Loosen 3/8" jam nut.
5. Turn the all-thread bolt until finger pressure of 5-10 lbs deflects the belt mid-section 1/4".
6. Move the engine closer to the power unit to loosen the belt. Move it away from the power unit to tighten the belt.
7. Tighten jam nut and engine bolts.
8. Replace belt guard.

LUBRICATE UNIT

Every 10 hours and before storage:

- Grease caster weldment.

CHECK ENGINE SPARK PLUG

Check and regap spark plug according to schedule in engine manual.

STORAGE



WARNING: AVOID INJURY. Read and understand *Storage Safety Rules* in *Safety* section before operating.

IMPORTANT: NEVER spray unit with water. **DO NOT** store unit outdoors.

Clean plastic surfaces with sponge and mild detergent. Dry with a soft cloth.

Remove all debris from can and hoses before storing. Remove all dirt, grease, leaves, etc. from unit.

Store in a clean, dry area.

Ensure all fasteners are properly tightened. Inspect moving parts for damage and wear.

Touch up all rusted or chipped painted surfaces.

TROUBLESHOOTING

| PROBLEM | PROBABLE CAUSE | CORRECTION |
|--|---|---|
| Catcher fails to pickup grass or leaves. | <ol style="list-style-type: none">1. Grass can is full.2. Catcher is clogged.3. Deck is clogged.4. Mowing too fast for conditions. | <ol style="list-style-type: none">1. Shut off engine, remove key and empty grass can.2. See <i>Unclogging Grass Catcher in Operation</i>.3. Remove clog according to deck's Operator Manual.4. Mow slower. |
| Impeller stops or slows. | <ol style="list-style-type: none">1. Worn or damaged belt. | <ol style="list-style-type: none">1. Replace belt. |

CATCHER ASSEMBLY

Model 890015

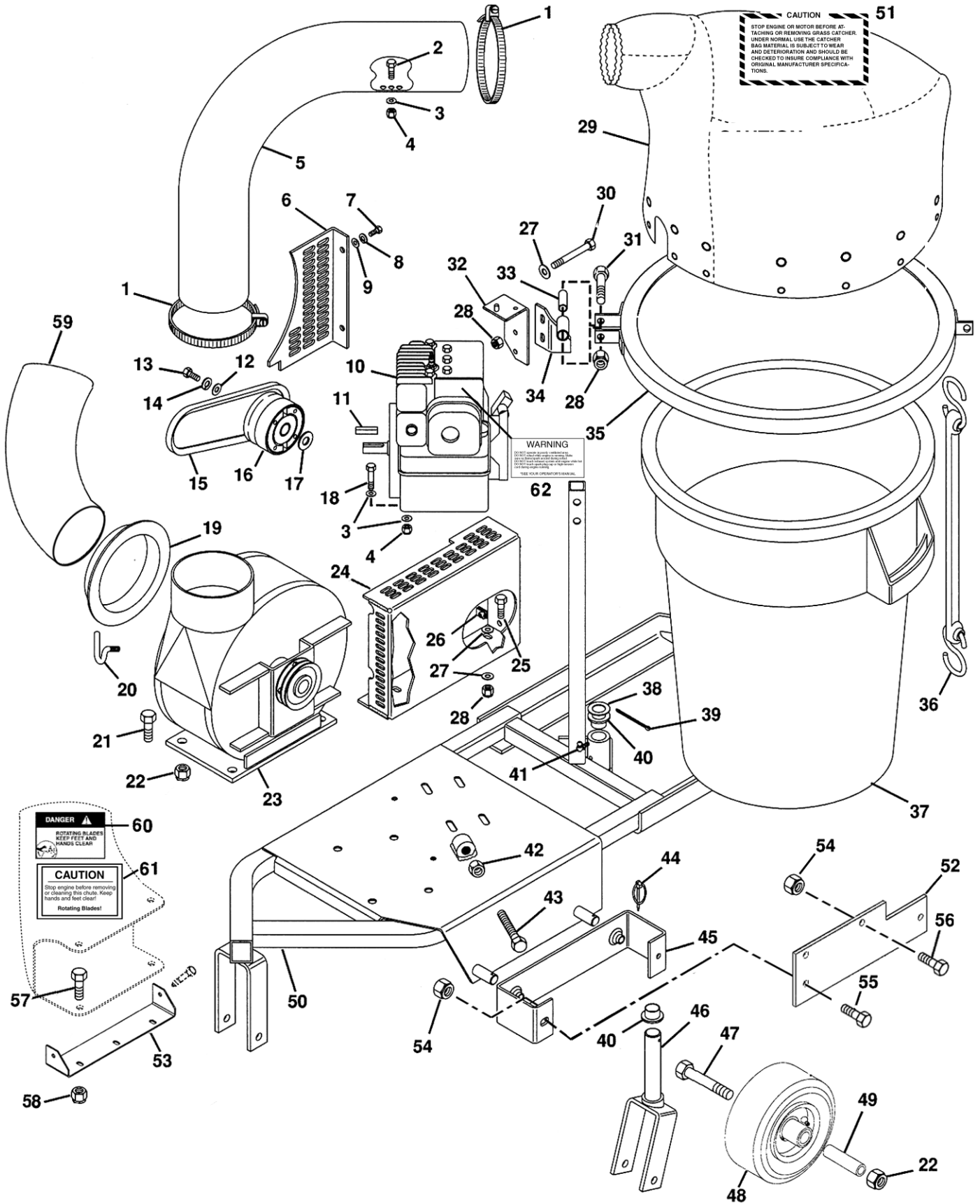

GB-10

CATCHER ASSEMBLY

Model 890015

| Item | Part No. | Qty. | Description |
|------|----------|------|--|
| 1 | 03444800 | 2 | Clamp |
| 2 | 05946900 | 2 | Bolt-Hex .31-18 x 1.00 Grade 5 |
| 3 | 06437200 | 10 | Washer-Flat .344 x .688 x .065 |
| 4 | 06529800 | 6 | Nut-Locking-Center .31-18 |
| 5 | 09032500 | 1 | Tube-Catcher |
| 6 | 08941700 | 1 | Cover-Guard |
| 7 | 05946800 | 2 | Bolt-Hex .25-20 x .75 Grade 5 |
| 8 | 06308400 | 2 | Washer-Locking .25 x .062 |
| 9 | 06437300 | 2 | Washer-Flat-Steel .281 x .620 x .065 |
| 10 | 08266600 | 1 | Engine, 5.5HP Kawasaki |
| 11 | 06609600 | 1 | Key-Hub .187 x 1.500 |
| 12 | 06435700 | 1 | Washer-Flat-Steel .38 x .875 x .083 |
| 13 | 05947300 | 1 | Bolt-Hex .31-24 x .75 Grade 5 |
| 14 | 06308600 | 1 | Washer-Locking .31 x .078 |
| 15 | 07221100 | 1 | V-Belt |
| 16 | 08941500 | 1 | Clutch |
| 17 | 06431900 | 1 | Race-Bearing-Thrust .060 |
| 18 | 05937400 | 4 | Bolt-Hex .31-18 x 1.75 Grade 5 |
| 19 | 04914351 | 1 | Weldment, Blower Adapter |
| 20 | 03444800 | 2 | Clamp-Screw |
| 21 | 05958900 | 4 | Bolt-Hex .50-13 x 1.25 Grade 5 |
| 22 | 06536300 | 8 | Nut-Locking-Center .50-13 |
| 23 | 69005000 | 1 | Assembly, PM-310 Blower |
| 24 | 08970200 | 1 | Guard |
| 25 | 05959400 | 2 | Bolt-Hex .38-16 x .75 Grade 5 |
| 26 | 07009000 | 2 | Nut-Retainer |
| 27 | 06436200 | 6 | Washer-Flat .406 x .812 x .065 |
| 28 | 06529600 | 7 | Nut-Locking-Center .38-16 |
| 29 | 08944900 | 1 | Cover-Grass Catcher |
| 30 | 05958400 | 2 | Bolt-Hex .38-16 x 2.50 Grade 5 |
| 31 | 05963300 | 1 | Bolt-Hex .38-16 x 2.00 |
| 32 | 08942700 | 1 | Bracket-Tube |
| | | | 33 08981100 1 Bushing .385 x .625 x 1.00 |
| | | | 34 08944600 1 Weldment-Pivot Bracket |
| | | | 35 08944300 1 Weldment-Ring |
| | | | 36 07528100 1 Strap-Hold Down |
| | | | 37 08707400 1 Can-Grass |
| | | | 38 05421600 1 Race-Bearing-Thrust |
| | | | 39 06712600 1 Pin-Center .12 x 1.25 |
| | | | 40 05422400 2 Bearing-Flanged |
| | | | 41 07012800 1 Fitting-Lube 90 Degree |
| | | | 42 06529400 1 Nut-Hex .38-16 |
| | | | 43 05941300 1 Bolt-Hex Spec. .38-16 x 3.00 |
| | | | 44 07014500 2 Pin-Klik |
| | | | 45 08981700 1 Weldment-Catcher Mount |
| | | | 46 08730400 1 Weldment-Castor |
| | | | 47 05964100 2 Bolt-Hex .50-13 x 5.50 |
| | | | 48 07128500 2 Wheel-Wing Gauge |
| | | | 49 08821900 2 Bushing-Axle |
| | | | 50 08981800 1 Weldment-Catcher |
| | | | 51 Caution Label (part of item 29) |
| | | | 52 04914451 1 Plate, Bagger Adapter |
| | | | 53 04918051 1 Bracket, Boot Mounting |
| | | | 54 06535300 2 Nut-Locking-Center .62-11 |
| | | | 55 05968700 2 Bolt-Hex .62-11 x 1.50 Grade 5 |
| | | | 56 05968100 2 Bolt-Hex .62-11 x 2.00 Grade 5 |
| | | | 57 05948700 2 Bolt-Hex .38-16 x 1.00 Grade 5 |
| | | | 58 06535800 2 Nut-Locking-Nylon .38-16 |
| | | | 59 04917500 1 Hose, Blower 8" x 40 |
| | | | 60 * 1 Boot Decal, Danger |
| | | | 61 * 1 Boot Decal, Caution |
| | | | 62 ** 1 Engine Decal, Warning |

* Contact Peco Industries, 1-828-684-1234.

** Contact Kawasaki Technical Support, 1-800-433-5640.

BLOWER ASSEMBLY

Model 890015

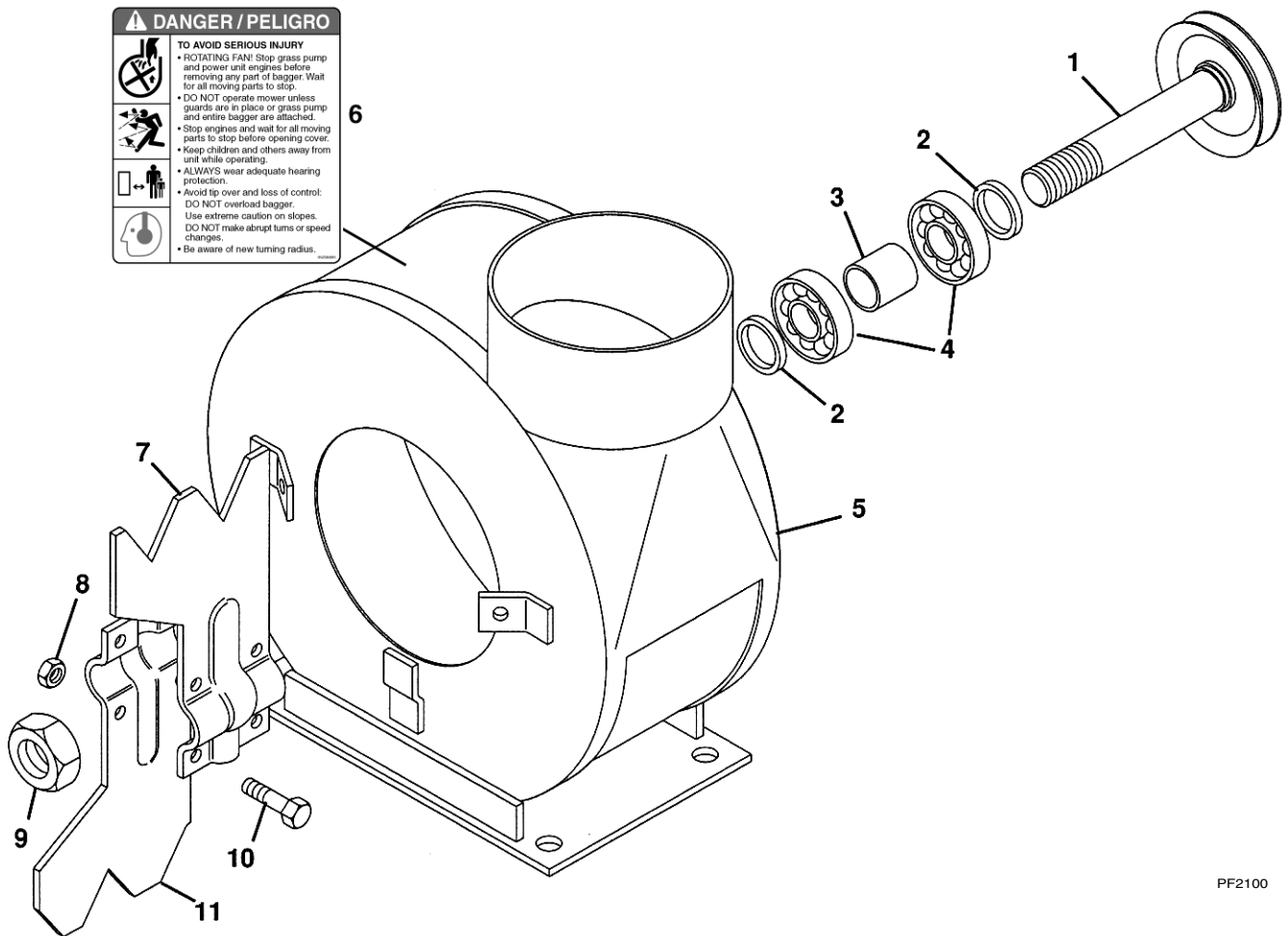

⚠ DANGER / PELIGRO

TO AVOID SERIOUS INJURY

- **ROTATING FAN!** Stop grass pump and power unit engines before removing any part of bagger. Wait for all moving parts to stop.
- DO NOT operate mower unless guards are in place or grass pump and entire bagger are attached.
- Stop engines and wait for all moving parts to stop before opening cover.
- Keep children and others away from unit while operating.
- ALWAYS wear adequate hearing protection.
- Avoid tip over and loss of control. DO NOT overload bagger.
- Use extreme caution on slopes. DO NOT make abrupt turns or speed changes.
- Be aware of new turning radius.

PF2100

| Item | Part No. | Qty. | Description |
|------|----------|------|--------------------------------------|
| 1 | 03422100 | 1 | Weldment-Spindle |
| 2 | 06418500 | 2 | Washer-Flat-Steel 1.015 x 1.5 x .125 |
| 3 | 21082200 | 1 | Spacer |
| 4 | 05416000 | 2 | Bearing-Ball 1.0 x 2.0 x .56 |
| 5 | 04914851 | 1 | Weldment, Fan Housing |
| 6 | 05234600 | 1 | Decal-Danger |
| 7 | 03021500 | 1 | Blade-Fan |
| 8 | 06529800 | 4 | Nut-Locking-Center .31-18 |
| 9 | 06512000 | 1 | Nut-Locking-Jam 1.0-14 |
| 10 | 05947000 | 4 | Bolt-Hex .31-18 x .75 Grade 5 |
| 11 | 03422000 | 1 | Blade-Fan |

WARRANTY



Gravely Division of Ariens Company
655 West Ryan Street
P.O. Box 157
Brillion, WI 54110-0157
920-756-2141
Fax 920-756-2407
www.gravely.com

2-Year Limited Warranty

Gravely Division of Ariens Company (Gravely) hereby warrants to the original consumer purchaser that all Gravely Two-Wheel, Professional G, Pro, and ProMaster products will be free from defects in material and workmanship for a period of two (2) years from the date of purchase or 1000 hours, whichever comes first.

Protection Plan

Gravely will repair or replace any part found upon examination by Gravely to be defective. Such repair or replacement will be free of charge to the purchaser (labor and parts), except as noted below.

This warranty is subject to the following exceptions, conditions, and limitations:

Usage Requirement

The duration of this warranty shall be ninety days or 1000 hours, whichever comes first, if the product is rented or leased.

Purchaser's Responsibilities

- The purchaser must perform maintenance and minor adjustments per the operator's manual.
- The purchaser must notify Gravely or an authorized Gravely service representative of the need for warranty service.
- The purchaser must transport the product to and from the place of warranty repair.

Product Registration

- Returning the product registration card to Gravely will enable the company to contact the registrant with repair or replacement part information.

Service Parts and Accessories

- Service parts and accessories not purchased with the product covered by this warranty are warranted to be free of defects for a period of ninety (90) days following the date of purchase, and will be replaced free of charge (except for labor).

Service

- Warranty service must be done by an authorized Gravely dealer. To find an authorized Gravely service representative, contact Gravely at the website, number or address above.

Battery Warranty Prorated

- One to three months - Free replacement
- Four to twelve months - Prorated over 12 months

Exclusions (No Warranty)

- Normal maintenance, services, and normal replacement items, such as spark plugs, oil, oil filters, air filters, mufflers, belts, tires, shoes, runners, scraper blades, shear bolts, mower blades, mower vanes, headlights, light bulbs, knives, etc. are not covered by this warranty.
- Any equipment which has been altered, misused, misassembled, improperly adjusted, neglected, or damaged by accident is not covered by this warranty.
- Service completed by someone other than an authorized Gravely dealer is not covered by this warranty.
- Any attachment not approved by Gravely nor any parts that are not genuine Gravely service parts are not covered by this warranty.
- Engines and engine accessories are covered only by the warranty made by the engine manufacturer, and are not covered by this warranty.
- If the product is equipped with a Hydro-Gear transmission and/or Hydro-Gear drive components, the Hydro-Gear transmission and/or drive components are covered only by the warranty made by Hydro-Gear, and are not covered by this warranty.
- This warranty applies only to products purchased in the United States (including Puerto Rico) and Canada. In all other countries, contact place of purchase.

Gravely may from time to time change the design of its products. Nothing contained in this warranty shall be construed as obligating Gravely to incorporate such design changes into previously manufactured products, nor shall such changes be construed as an admission that previous designs were defective.

LIMITATION OF REMEDY AND DAMAGES

Gravely's liability under this express warranty, and under any implied warranty that may exist, is limited to repair or replacement of any defective part. In no event shall Gravely be liable for incidental, special, or consequential damages (including lost profits). This warranty gives you specific legal rights. You may also have other rights which vary from state to state. Some states do not allow the exclusion of incidental or consequential damages, or limitations on how long an implied warranty lasts, so the above limitations and exclusions may not apply to you.

DISCLAIMER OF FURTHER WARRANTY

Gravely makes no warranty other than what is expressly made in this warranty. If the law of your state provides that an implied warranty of merchantability, or an implied warranty of fitness for a particular purpose, applies to Gravely, any such implied warranty is limited to the duration of this express warranty.

Form: GLW2-122002



GRAVELY

A Division of Ariens Company

655 West Ryan Street

P.O. Box 157

Brillion, WI 54110-0157

920-756-2141

Fax 920-756-2407

www.gravelly.com

Free Manuals Download Website

<http://myh66.com>

<http://usermanuals.us>

<http://www.somanuals.com>

<http://www.4manuals.cc>

<http://www.manual-lib.com>

<http://www.404manual.com>

<http://www.luxmanual.com>

<http://aubethermostatmanual.com>

Golf course search by state

<http://golfingnear.com>

Email search by domain

<http://emailbydomain.com>

Auto manuals search

<http://auto.somanuals.com>

TV manuals search

<http://tv.somanuals.com>