

## ML6131 Direct Coupled Actuator

### PRODUCT DATA



### FEATURES

- Mounts directly on damper shaft.
- 6 lb-in. torque.
- Selectable 45°, 60°, and 90° stroke in either clockwise (cw) or counterclockwise (ccw) directions.
- 15 second timing model suitable for use with pressure independent VAV systems.
- Magnetic coupling typically provides a maximum of 18 lb-in. stall torque eliminating the need for mechanical stops or limit switch adjustments.
- Two field-addable auxiliary switches.
- Field-addable auxiliary feedback potentiometer.
- Models available with 0° to 30° minimum position adjustment in cw or ccw directions.
- Compatible for use with Honeywell W7620 Terminal Unit Controller.
- Can be used with the Commercial Zone Damper in the W7600 Commercial Zone System.
- Manual declutch on some models.

### APPLICATION

The ML6131 Direct Coupled Actuator (DCA) is used to control dampers in applications such as variable air volume (VAV) terminal units. It is suitable for use with single pole double throw (spdt) floating thermostats or two-position control systems.

### Contents

Application .....	1
Features .....	1
Specifications .....	2
Ordering Information .....	2
Installation .....	3
Operation .....	8
Checkout .....	8

## SPECIFICATIONS

### Models:

ML6131B: 6 lb-in. torque, selectable 45°, 60°, and 90° stroke in both cw and ccw directions. 15 second timing, spdt Floating Series 60, includes auxiliary potentiometer drive for use with field-addable feedback potentiometer. Includes minimum position adjustment setscrews for cw or ccw operation. Includes 4074ENJ Bag Assembly.

**Dimensions:** See Fig. 1.

**Electrical Ratings:** Input Voltage: 24 Vac  $\pm$ 20%, 50/60 Hz.

**Power Consumption (Maximum), at 24 Vac:** 2.2W, 0.095A, 2.4 VA.

### Ambient Ratings:

Operating Temperature: 32°F to 130°F (0°C to 54°C).  
Shipping and Storage: -20°F to 120°F (-29°C to 49°C).  
Humidity: 5% to 95% RH noncondensing.

**Torque Ratings:** See Table 1.

**Minimum Life Cycle Rating:** 400,000.

**Repositions:** 1.5 million.

### Actuator Timings (At 50 Hz Nominal):

90°-18 sec.  
60°-12 sec.  
45°-9 sec.

### Actuator Timings (At 60 Hz Nominal):

90°-15 sec.  
60°-10 sec.  
45°-7.5 sec.

### Damper Shaft Mounting:

- Suitable for mounting onto 3/8 to 1/2 in. square or round damper shafts secured by two 1/4 in. 28 NF Allen screws.
- Minimum damper shaft length 1-3/4 in. (45 mm).
- Actuator may be mounted with actuator shaft in any position.

### Feedback Potentiometer Ratings (ML6131B):

200976A,C Electrical Rating: 24 Vac, 50/60 Hz, 2.25 watts.

### Resistance Output (Resistance Linear as Measured Between Terminal R-B):

0 ohms (at 0 degree, cw stroke).  
250 ohms (at 45 degree, cw stroke).  
333 ohms (at 60 degree, cw stroke).  
500 ohms (at 90 degree, cw stroke).

**Auxiliary Switch Ratings:** Electrically selective NO or NC, not simultaneous.

**Pilot Duty:** 40 VA, 24 Vac.

**Switch Differential:** 3 angular degrees maximum.

### Approvals:

Underwriters Laboratories Inc. Component Recognized:  
File No. E4436; Guide No. XAPX2.  
CSA Certified (includes auxiliary switch).

### Accessories:

201052A One Auxiliary Switch.  
201052B Two Auxiliary Switch.  
201052C Three Auxiliary Switch.  
200976A 0 to 500 ohm Auxiliary Potentiometer.  
200976C 0 to 2000 ohm Auxiliary Potentiometer.  
4074ENJ Bag Assembly—includes stop pin, shaft adapter, and minimum position screw.  
4074ENY Bag Assembly—includes stop pin and shaft adapter.  
4074EVK Short Shaft Extension Kit—to adapt actuator output hub to short VAV damper shafts.  
7640QW Metal Enclosure—for running conduit to actuator.

**Table 1. Torque Ratings.**

	Torque
Running	6 lb-in. (0.7 N•m)
Breakaway	6 lb-in. (0.7 N•m)
Stall (Typical)	7.5 lb-in. (0.8 N•m) minimum 18 lb-in. (2.0 N•m) maximum

## ORDERING INFORMATION

When purchasing replacement and modernization products from your TRADELINE® wholesaler or distributor, refer to the TRADELINE® Catalog or price sheets for complete ordering number.

If you have additional questions, need further information, or would like to comment on our products or services, please write or phone:

1. Your local Home and Building Control Sales Office (check white pages of your phone directory).
2. Home and Building Control Customer Logistics  
Honeywell Inc., 1885 Douglas Drive North  
Minneapolis, Minnesota 55422-4386

In Canada—Honeywell Limited/Honeywell Limitée, 155 Gordon Baker Road, North York, Ontario M2H 3N7.

International Sales and Service Offices in all principal cities of the world. Manufacturing in Australia, Canada, Finland, France, Germany, Japan, Mexico, Netherlands, Spain, Taiwan, United Kingdom, U.S.A.

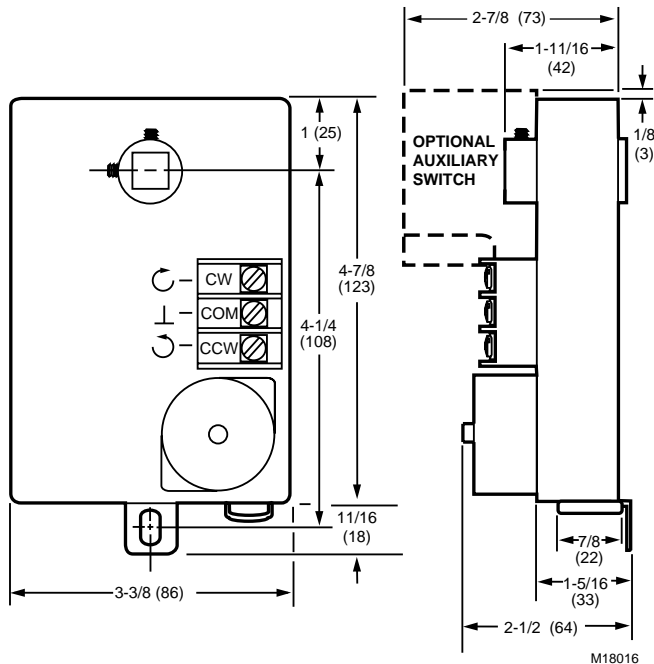

Fig. 1. Approximate dimensions of ML6131 Direct Coupled Actuator in in. (mm).

## INSTALLATION

### When Installing this Product...

1. Read these instructions carefully. Failure to follow them could damage the product or cause a hazardous condition.
2. Check the ratings given in the instructions and on the product to make sure the product is suitable for your application.
3. Installer must be a trained, experienced service technician.
4. After installation is complete, check out product operation as provided in these instructions.

### IMPORTANT

All wiring must agree with applicable codes, ordinances and regulations.

## ! WARNING

**Explosion Hazard.**  
A spark from the actuator or attached accessories can result in serious injury or death. Install the actuator in areas free of escaping gas and other explosive vapors.

## ! CAUTION

**Electrical Shock or Equipment Damage Hazard.**  
Can shock individuals or short equipment circuitry. Disconnect all power supplies before installation. Actuators with auxiliary switches can have more than one disconnect.

## ! CAUTION



**Actuator Damage Hazard.**  
Deteriorating vapors and acid fumes can damage the actuator metal parts.

Install actuator in areas free of acid fumes and deteriorating vapors.

### Location

Choose a location for the actuator that allows enough clearance for mounting accessories and for servicing.

### Mounting

These actuators are designed to open a damper or valve by driving the shaft in either the clockwise (cw)  or counterclockwise (ccw)  direction. The actuator has a mounting tab on the bottom that secures it to a damper box or valve linkage. When mounted correctly, this tab allows the actuator to float without rotating relative to the shaft. The tab is sized for 1/4 in. self-tapping sheet metal screws (not included).

## ! CAUTION

**Equipment Damage Hazard.**  
Tightly securing mounting tab to damper housing can damage actuator.

Once mounted, the actuator must be allowed to float; do not fully tighten the screw.

These actuators are shipped in the fully clockwise 90° position as viewed from the end of the damper shaft.

## ! CAUTION

**Equipment Damage Hazard.**  
Mounting actuator unevenly with damper housing can damage actuator.

Mount actuator flush with damper housing or add spacer between mounting tab and damper box housing (see Fig. 2).

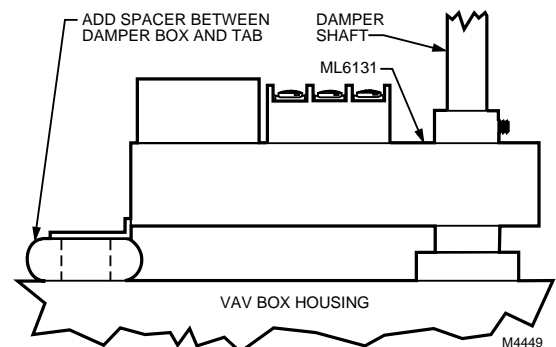

Fig. 2. Mounting actuator to VAV box when actuator is not flush with box.

## Preparation

Before mounting the actuator onto the shaft, determine the following:

1. Size of the shaft (3/8 in. to 1/2 in.).
2. Direction the shaft rotates to open the device (cw or ccw). See Fig. 3.
3. Degrees of actuator stroke for opening device (45°, 60°, or 90°).

If the shaft is 3/8 in. round or square, use part number 201391 Shaft Adapter provided inside the bag assembly shipped with the actuator. Place the adapter opposite the setscrews (see Fig. 4).

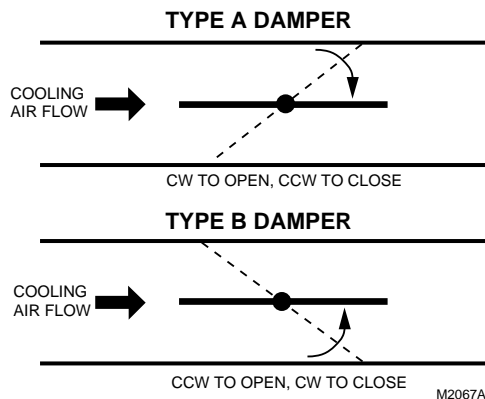

Fig. 3. Determining direction damper shaft rotates when opening.

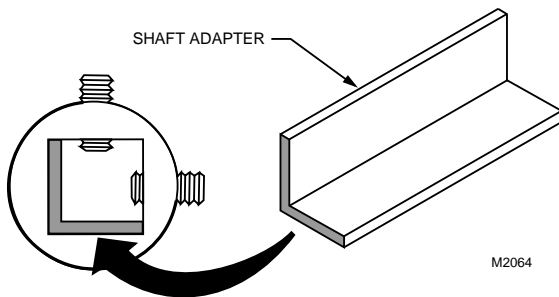

Fig. 4. Using shaft adapter for 3/8 in. shafts.

## Manual Operation (Declutch)

### CAUTION

**Personal Injury and Product Damage Hazard.**  
Do not use manual declutch without supporting the load.

Support load independent of actuator immediately prior to and while using manual declutch lever.

Manual declutch capability is available on some actuators. Use the manual declutch lever to manually adjust the actuator setting. Fig. 5 shows the location of the manual declutch lever. To operate, push the lever in the direction of the arrow on the lever cover.

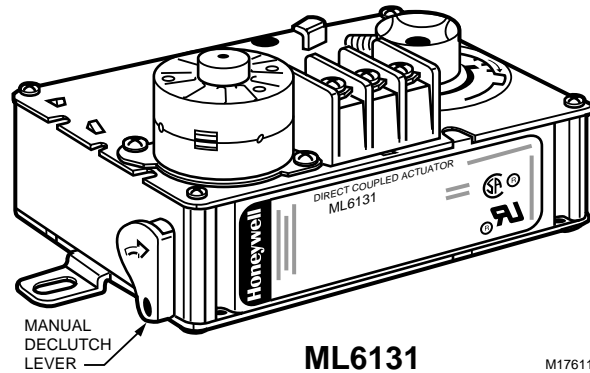

Fig. 5. Location of manual declutch lever.

## Installation

After determining the direction of the shaft rotation (cw or ccw), install the device. For valve linkage mounting, refer to the instructions shipped with the linkage. For damper mounting, proceed as follows:

1. Place the actuator onto the damper shaft.



### CAUTION

**Equipment Damage Hazard.**  
Improper range stop selection can damage light-duty dampers.

Be sure to select the proper range stop.

2. If the angle of the damper opening is either 45° or 60°, close the actuator using the manual declutch:
  - a. Disengage the hub using the declutch lever; see Manual Operation (Declutch) section.
  - b. Rotate the hub until the actuator gear train passes the proper 45° or 60° setting. (Do not insert the pin until after the actuator passes this point.)
  - c. Release the declutch lever.

NOTE: Dampers with 90° stroke do not require the range stop pin.

3. Insert the range stop pin into the appropriate (cw or ccw) 45° or 60° slot. The range stop pin is clipped into its final position only after the pin passes through both actuator plates (see Fig. 6). The range stop pin should snap into position and not be removable manually (see Fig. 7).

### IMPORTANT

*Do not fully tighten the mounting screw; the actuator must be allowed to float.*

4. With the actuator placed in its final position, secure the mounting tab to the damper box with a sheet metal screw.
5. Position the damper in the open position and securely tighten the Allen screws into the damper shaft.

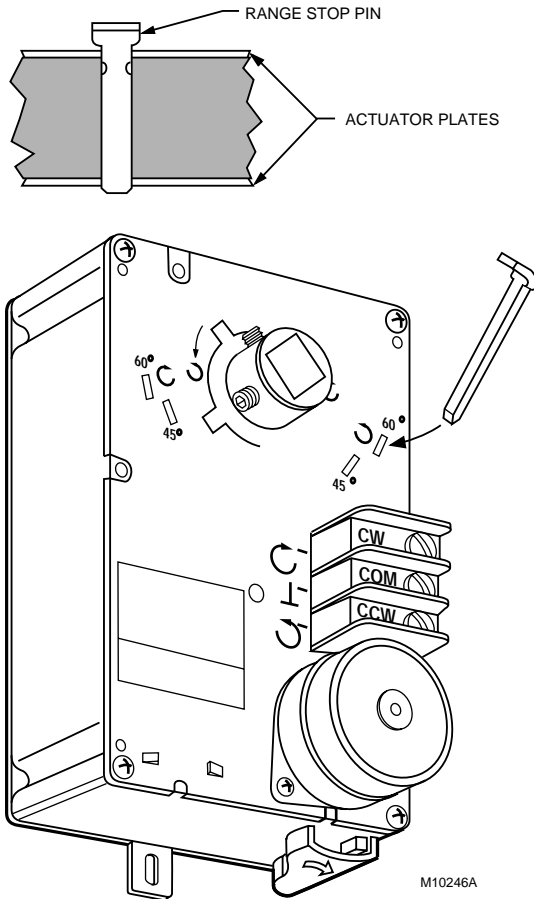

Fig. 6. Range stop pin properly inserted.

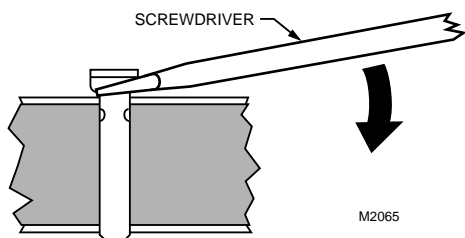

Fig. 7. Lifting a range stop pin out of its slot.

### Minimum Position Setscrew

Certain ML6131 models are equipped with two tapped holes located in the plastic housing at the top of the actuator. These holes can be used with the minimum position setscrew and locknut inside the 4074ENJ Bag Assembly (see Fig. 6). The setscrew provides for a 0° to 30° minimum position adjustment.

**NOTE:** Before starting operation, note that the 1/4 in. minimum position setscrew limits closing motion, while the range stop pin limits opening motion.

1. Determine the direction of the desired closing rotation.
2. Move the actuator to the position fully opposite the desired closing rotation (if cw closing rotation is desired, move the actuator to the full ccw position).
3. Determine the correct hole for the setscrew using Fig. 8 and the results of step 1.

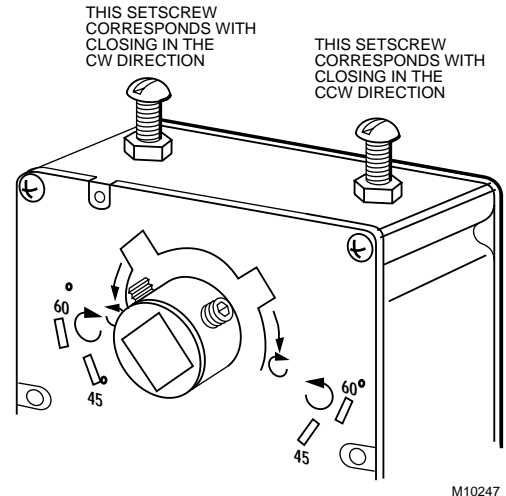

Fig. 8. Setscrew location for ML6131.



### CAUTION

**Equipment Damage Hazard.**  
Improper hub positioning or hole selection can permanently damage the device.  
Avoid backdriving the actuator with the setscrew.

4. Remove the red cap from the desired hole. Leave the other cap in position. The caps ensure that dust and other impurities do not enter the gear train through unused holes.
5. Thread the locknut fully onto the 1/4 in. setscrew.
6. Insert the setscrew into the desired hole, turning clockwise until resistance is encountered or the locknut contacts the housing.
7. If resistance is met before the setscrew is fully inserted, stop and review the initial setup procedures as detailed in steps 1 through 3.
8. Determine the angle of minimum position required for the application. With the setscrew fully inserted, the minimum position is 30°. With the setscrew fully out, the minimum position is 0°.
9. Using the conversion of approximately 1.7 angular degrees of shaft rotation per turn of the setscrew, back the screw out of the housing and stop slightly short of the calculated position. This allows the setscrew to be set accurately while taking air flow measurements.

### IMPORTANT

After initiating step 10, the setscrew cannot be turned into the housing without returning the actuator to the fully open position (as determined in step 1). The actuator follows the setscrew without damaging the housing only when backed out of the housing (turned ccw).

10. Rotate the actuator to minimum position using the manual declutch; see Manual Operation (Declutch) section.
11. With the actuator at minimum position, adjust the position more accurately using air flow measurements.

**IMPORTANT**

- After each adjustment, ensure the actuator is completely stopped before proceeding with the next adjustment.
- To reduce the minimum position, turn out the setscrew (ccw). The actuator then drives toward the closed position.
- Turning the setscrew in (cw) damages the actuator housing.
- If the device is too far closed, return to step 1.

12. When proper air flow is achieved, loosen the locknut from the setscrew until it contacts the actuator housing, then turn it an additional 1/8 turn to lock the setscrew in place.

**IMPORTANT**

Run an entire check of the operation after completing this procedure.

**Wiring**

**CAUTION**

**Electrical Shock or Equipment Damage Hazard.**  
Can shock individuals or short equipment circuitry.

Disconnect all power supplies before installation. Actuators with auxiliary switches can have more than one disconnect.

All wiring must comply with local electrical codes, ordinances and regulations. Voltage and frequency of the transformer used with the actuator must correspond with the characteristics of both the power supply and the actuator. Screw terminals are provided for easy hookup. See Fig. 9 for typical wiring.

**Auxiliary Switches**

The 201052A, B or C Auxiliary Switch is used in conjunction with the actuator. It allows for control of equipment external to the actuator (for example, electric reheat coils and fan) at an adjustable point in the stroke (0° to 90°) of the actuator.

The 201052A, B and C Auxiliary Switches are field-addable. For mounting instructions, see form 63-2218, provided with the device.

**IMPORTANT**

When operating an ML6131 from a two-position controller, a 201052B Auxiliary Switch is required for proper operation. See Fig. 10.

NOTE: See Fig. 11 for the 201052B Auxiliary Switch wiring.

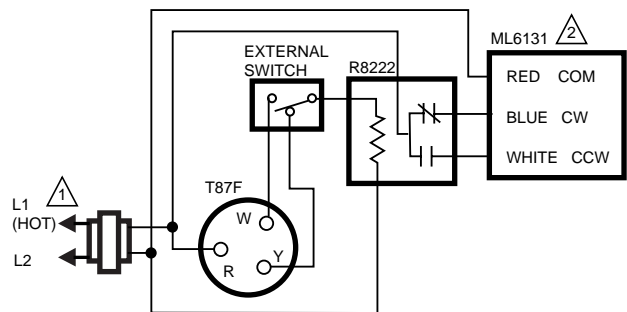

1 POWER SUPPLY. PROVIDE DISCONNECT MEANS AND OVERLOAD PROTECTION AS REQUIRED.

2 AUXILIARY SWITCHES ARE REQUIRED TO TURN OFF THE MOTOR AT EACH END OF THE STROKE.

M17613

**Fig. 9. ML6131 used with T87F in heating-only or cooling-only application.**

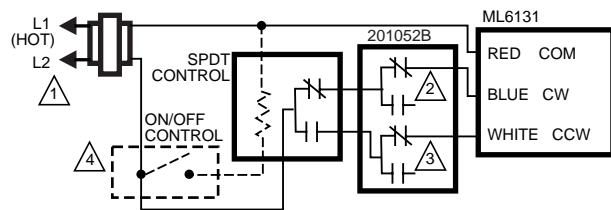

1 POWER SUPPLY. PROVIDE DISCONNECT MEANS AND OVERLOAD PROTECTION AS REQUIRED.

2 SET SWITCH TO CLOSE WHEN STROKE REACHES FULL CW POSITION.

3 SET SWITCH TO CLOSE WHEN STROKE REACHES FULL CCW POSITION.

4 ON-OFF CONTROL REQUIRES AN R8222 SPDT RELAY IN PLACE OF THE SPDT CONTROL.

M17612

**Fig. 10. 201052B Auxiliary Switch wiring.**

## Auxiliary Potentiometers

The 200976 Auxiliary Potentiometer mounts on the face of certain ML6131A actuators as shown in Fig. 11. The potentiometer shaft has a slipping collar, which means that if one of the two limits of the potentiometer is exceeded, the collar will continue to rotate, causing no damage to the potentiometer itself. To mount the potentiometer on the actuator:

1. Turn the potentiometer to align the shaft key with the slot in the potentiometer drive.
2. Tilt the potentiometer slightly so the key faces down toward the slot.
3. Insert the potentiometer into the slot, and push down so the potentiometer is flush with the actuator body and the bracket is aligned over the screw hole.
4. Insert the screw provided into the hole and fasten securely.

### IMPORTANT

*Failure to follow the calibration procedures can result in improper resistance values at desired stroke.*

### To Calibrate the 200976A,C:

### IMPORTANT

*Remove the range stop pins and minimum position setscrews prior to calibration.*

1. Drive the actuator fully closed (0°) to fully open (90°) and back again to the fully closed position. This must be done to receive the correct resistance readings at the appropriate degree of stroke.
2. Check the resistance values of the potentiometer with an ohmmeter at intervals in the stroke while referring to the table in Fig. 11 and resistance information provided in the Specifications section.
3. Replace the range stop pins and/or the minimum position setscrews using the appropriate procedures.

AUXILIARY POTENTIOMETER

MOTOR POSITION	RW RESISTANCE	RB RESISTANCE
FULLY CW 24V (COM-CW)	0 OHMS	500 OR 2000 OHMS
FULLY CCW 24V (COM-CCW)	500 OR 2000 OHMS	0 OHMS

MOTOR ROTATION	AUXILIARY POTENTIOMETER LEADS	
	RW OHMS	RB OHMS
CCW	INCREASE	DECREASE
CW	DECREASE	INCREASE

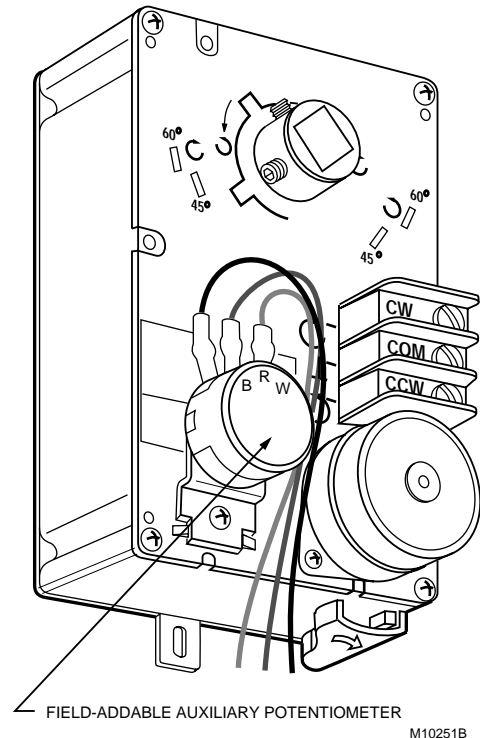

Fig. 11. ML6131 with field-addable potentiometer.

## OPERATION

### VAV Systems

VAV systems control the temperature within a space by varying the volume of supply air. Air is delivered to the space at a fixed temperature. The volume of supply air is controlled by the space thermostat modulating the supply air damper. When full heating and cooling flexibility is required in a zone, it is handled by temperature air system, or with reheat capability in the air terminal units. As individual zones shut down, the total air flow in the system is regulated by a central duct static pressure controller. The fan system is sized to handle an average peak load, not the sum of the individual peaks. As each zone peaks at a different time of day, extra air is borrowed from the off-peak zones. This transfer of air from low-load to high-load zones occurs only in true VAV systems.

In pressure independent systems, individual zone airflow sensors are used to maintain the zone air flow rate regardless of fluctuation in the total system pressure.

Pressure independent systems, when used with controllers such as the W7620, can react faster to changes in air flow demand. Therefore, these systems can use the faster 15 second ML6131 models.

### Parallel Actuators

#### **IMPORTANT**

*Over time, parallel-driving actuators can become out of sync with each other. Normally, driving all actuators to the fully-open or fully-closed position puts them back in sync.*

Using Fig. 9, parallel the CW, COM and CCW terminals. Make certain the total connected load does not exceed the current capacity of the controller or thermostat.

## CHECKOUT

To check out the ML6131, determine the direction the damper shaft moves to open the damper (cw or ccw). See Fig. 3:

1. Place 24 Vac across the appropriate COM and CW or COM and CCW terminals to energize the actuator. The ML6131 should begin to open the damper.
2. If the actuator does not run, switch the 24 Vac across the opposite COM and CW or COM and CCW terminals to determine if the damper will begin to close.
3. If the actuator does not run in either direction, replace the ML6131.

In the event the ML6131 is used with a spdt floating wall thermostat (pressure dependent systems):

1. Adjust the setpoint of the thermostat to call for cooling.
2. Observe the operation of the actuator; if the device is closed, it should begin to open.
3. If not, adjust the setpoint of the thermostat higher to determine if the wiring is correct.
4. If no movement is observed, check for the presence of 24 volts.
5. If using the T641 Thermostat, check that 24 volts are present between terminals C and Y during a call for cooling. With proper wiring and 24 volts present, the actuator should operate correctly.
6. If not, replace the actuator.

**NOTE:** When the ML6131 is used with electronic control systems such as the W7620, override the control system by programming the controller to open/close the zone damper as appropriate.

# Honeywell

#### Home and Building Control

Honeywell Inc.  
Honeywell Plaza  
P.O. Box 524  
Minneapolis, MN 55408-0524

#### Home and Building Control

Honeywell Limited-Honeywell Limitée  
155 Gordon Baker Road  
North York, Ontario  
M2H 3N7





## Free Manuals Download Website

<http://myh66.com>

<http://usermanuals.us>

<http://www.somanuals.com>

<http://www.4manuals.cc>

<http://www.manual-lib.com>

<http://www.404manual.com>

<http://www.luxmanual.com>

<http://aubethermostatmanual.com>

Golf course search by state

<http://golfingnear.com>

Email search by domain

<http://emailbydomain.com>

Auto manuals search

<http://auto.somanuals.com>

TV manuals search

<http://tv.somanuals.com>