

04973 Series Conductivity Cells

Installation and Maintenance Manual

70-82-25-17

10/07

Copyright, Notices, and Trademarks

Printed in U.S.A. – © Copyright 2007 by Honeywell Inc.
Revision– 10/07

Warranty/Remedy

Honeywell warrants goods of its manufacture as being free of defective materials and faulty workmanship. Contact your local sales office for warranty information. If warranted goods are returned to Honeywell during the period of coverage, Honeywell will repair or replace without charge those items it finds defective. The foregoing is Buyer's sole remedy and is **in lieu of all other warranties, expressed or implied, including those of merchantability and fitness for a particular purpose**. Specifications may change without notice. The information we supply is believed to be accurate and reliable as of this printing. However, we assume no responsibility for its use.

While we provide application assistance personally, through our literature and the Honeywell web site, it is up to the customer to determine the suitability of the product in the application.

Honeywell Field Solutions
512 Virginia Drive
Fort Washington, PA 19034

Brands or product names are trademarks of their respective owners

About This Document

Abstract

The purpose of this manual is to support the installation and maintenance of the 4973 Series Conductivity Cells.

Revision Notes

The following list provides notes concerning all revisions of this document.

Rev. ID	Date	Notes
0	10/96	This document is the initial release of the Honeywell version of the 4973 Series Conductivity Cell Installation and Maintenance Manual. This publication was originally released under the L&N system as 277067 Rev. N1.
1	6/99	Edits were made to add information for the 9782C and to correct some erroneous information.
2	6/03	Edits were made to add information for the DL43XX Cells for DirectLine Modules
3	6/04	Edit text and update the Installation drawings to remove 7082 information.
4	10/05	Edit text and add electrical connection drawings for UDA2182 analyzer
5	10/07	Edit text, add CRN approval, add quick disconnect info.

References

Honeywell Documents

The following list identifies all Honeywell documents that may be sources of reference for the material discussed in this publication.

Document Title	ID #
APT2000CC Transmitter User Manual	70-82-25-95
APT4000CC Analyzer User Manual	70-82-25-104
UDA2182 Analyzer User Manual	70-82-25-119

Contacts

World Wide Web

<http://hpsweb.honeywell.com>

Telephone

Contact us by telephone at the numbers listed below.

	Organization	Phone Number	
United States and Canada	Honeywell	1-800-423-9883	<i>Tech. Support</i>

Contents

1. INTRODUCTION	1
1.1 Overview	1
1.2 Description	1
2. SPECIFICATIONS.....	4
2.1 Specifications for 04973 Series	4
2.2 Specifications for 055919 Flow Chamber	4
3. INSTALLATION	5
3.1 General Requirements	5
3.2 The Differences between the Quick Disconnect and Integral Cable Option	5
3.3 In-Line Type Mounting	6
3.4 Flow-Type Mounting	6
3.5 Torque Recommendations	7
3.6 Dimension Drawings	7
4. ELECTRICAL CONNECTIONS.....	10
4.1 Overview	10
4.2 Instrument Wiring for 4973 Cells with Integral Cable.....	10
4.2.1 Model 4973 Series with Integral Cable to UDA2182 Analyzer	10
4.2.2 Model 4973 Series with Integral Cable to APT Series Analyzer/Transmitter.....	12
4.3 Instrument Wiring for 4973 Cells with Quick Disconnect Cable.....	13
4.3.1 Wiring Model 4973 with Quick Disconnect Cable to UDA2182.....	13
4.3.2 Wiring Model 4973 with Quick Disconnect Cable to Junction Box	13
4.3.3 Wiring Model 4973 with Quick Disconnect Cable to APT.....	14
5. MAINTENANCE	15
5.1 Overview	15
5.2 To Clean the Cell.....	15
5.3 Check Conductivity System	15
5.4 Troubleshooting.....	15
5.5 Air Entrapped in Cell Flow Channel	16
6. ACCESSORIES AND SPARE PARTS	17

Figures

Figure 1-1 4973 Type Conductivity Cells, for Flow and Insertion-type Applications. _____	2
Figure 1-2 Recommended Locations for Mounting a Conductivity Cell _____	3
Figure 1-3 Two Piping Arrangements for the Cell _____	3
Figure 3-1 Dimension Drawing for 055919 Flow Chamber _____	7
Figure 3-2 Dimension Drawing for 31079198 Flow Chamber _____	8
Figure 3-3 Outline and Dimensions for Conductivity Cell with Universal Head _____	8
Figure 3-4 Outline and Dimensions for Conductivity Cell with Integral Cable _____	9
Figure 4-1 Installation Diagram, 4973 Cells, with junction box head connected to UDA2182 Analyzer	10
Figure 4-2 Installation Diagram, 4973 Cells, with Integral Cable Leads Directly Connected to UDA2182 Analyzer or Connected to Junction Box _____	11
Figure 4-3 Model 4973 Series to APT Series Analyzer/Transmitter _____	12
Figure 4-4 Wiring Diagram for 4973 Cells with Quick Disconnect Cable Connected to UDA2182 Analyzer _____	13
Figure 4-5 Installation diagram for 4973 cells with Quick Disconnect Cable connected to junction box	13
Figure 4-6 Wiring Diagram for 4973 Cells with Quick Disconnect Cable Connected to APT4000 _____	14
Figure 4-7 Wiring Diagram for 4973 Cells with Quick Disconnect Cable Connected to APT2000 _____	14

1. Introduction

1.1 Overview

The **4973 Type cells**, Figure 1-1, have a rugged configuration for reliable, continuous measurements of electrolytic conductivity in industrial water processes at temperatures up to 140°C at 250 psig. They are applicable to such measurements as the effluent of distillation equipment; anion, cationic and mixed bed ion exchangers; monitoring and controlling of washing electronic components; plating rinse tank control; boiler water condensate; boiler hot well measurements and cooling tower blowdown, and many others.

Made of polyethersulfone (PES) construction for high-corrosion resistance, the cells are supplied with 0.01 and 0.1 cell constants having titanium electrodes, and 1.0 and 10.0 cell constants with high-density, graphite electrodes.

The 4973 Cells used with UDA2182 Series or APT2000/4000 Series are equipped with the choice of:

- integral standard 20 or 50 foot lead
- quick disconnect cable option
- junction box type (universal) head with terminal connections for longer lead lengths.

For in-line applications, the 3/4" NPT male thread permits permanent installation in a pipe or tank; the cell may also be used as a laboratory dip-type cell for batch sampling.

For flow applications, the cell can be installed directly into a process stream as shown in Figure 1-2 by using a Flow Chamber or a 3/4" pipe tee as shown in Figure 1-3. These arrangements are designed to keep both the temperature compensator and cell in the main stream flow so that the cell will respond more quickly and accurately to process changes of both solution concentration and temperature.

A 316SS (P/N 31079198) and a PES (P/N 055919) Flow Chamber is available from Honeywell.

1.2 Description

All conductivity cells of the 4973 Type are suitable for use in both flow and insertion - type installations. They are one-piece molded units that cannot come apart and therefore have no replacement parts. Each has a 3/4" NPT thread.

The physical appearance of the cells is shown in Figure 1-1. The 0.01, 0.1, 1 and 10 cell constants are similar in construction with differences as noted below.

0.01 and 0.1 Cell Constants

The 0.01 cell differs from the others only by its outer electrode length of 2-3/4". The temperature compensation sensor is located inside the inner electrode. The holes in the outer electrode provide passage for the solution being measured. The 0.1 cell is similar to the 0.01 type except that its outer electrode length is 2". The temperature compensation sensor is located inside the inner electrode.

1 and 10 Cell Constants

The 1 and 10 cell constant types are similar but differ in the width of flow channel (that serves to conduct the solution being measured past the electrodes of the cell) as well as size and spacing of the electrodes. The electrodes are graphite, 1/4" D for the 1 cell constant and 1/8" D for the 10 cell constant. The temperature compensating sensor is integral with the cell body.

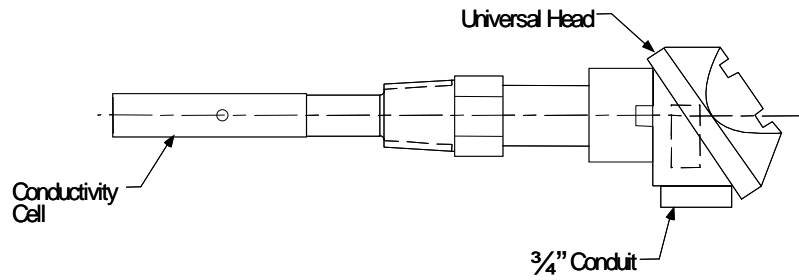
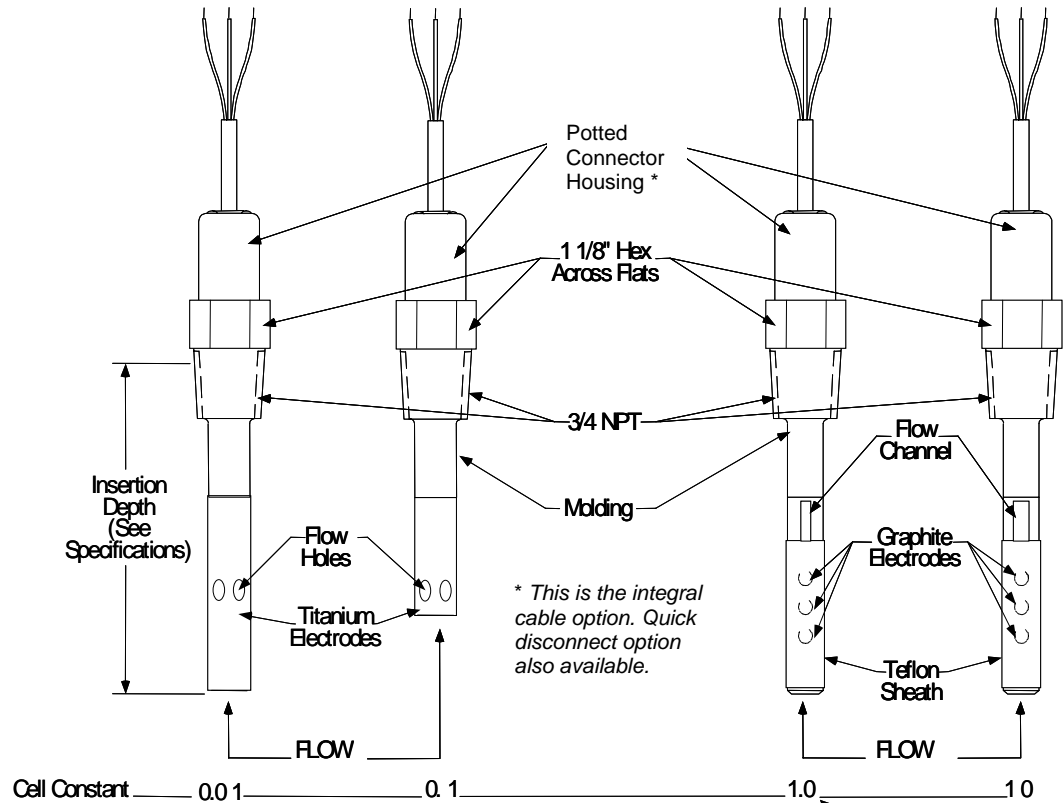
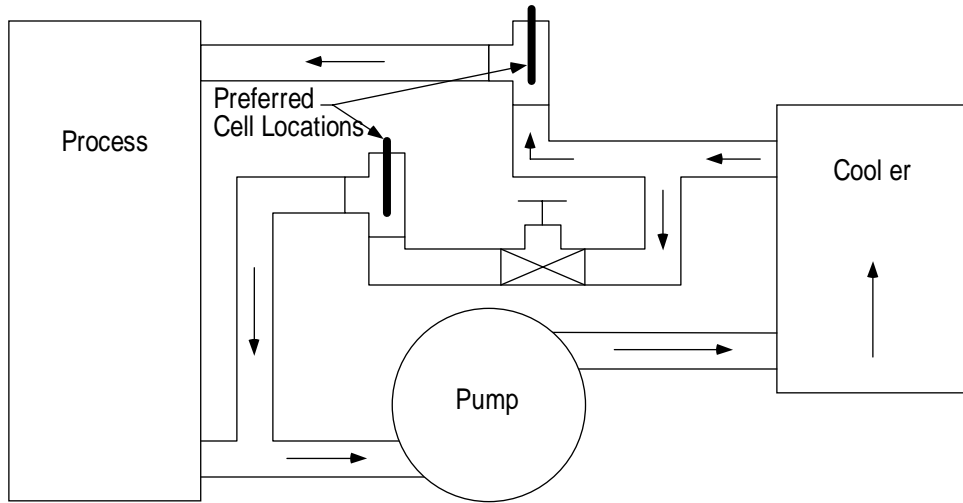

Figure 1-1 4973 Type Conductivity Cells, for Flow and Insertion-type Applications.

ATTENTION

Do not remove the Teflon sheath on 1.0 and 10 constant cells.



a/n 23340

Figure 1-2 Recommended Locations for Mounting a Conductivity Cell

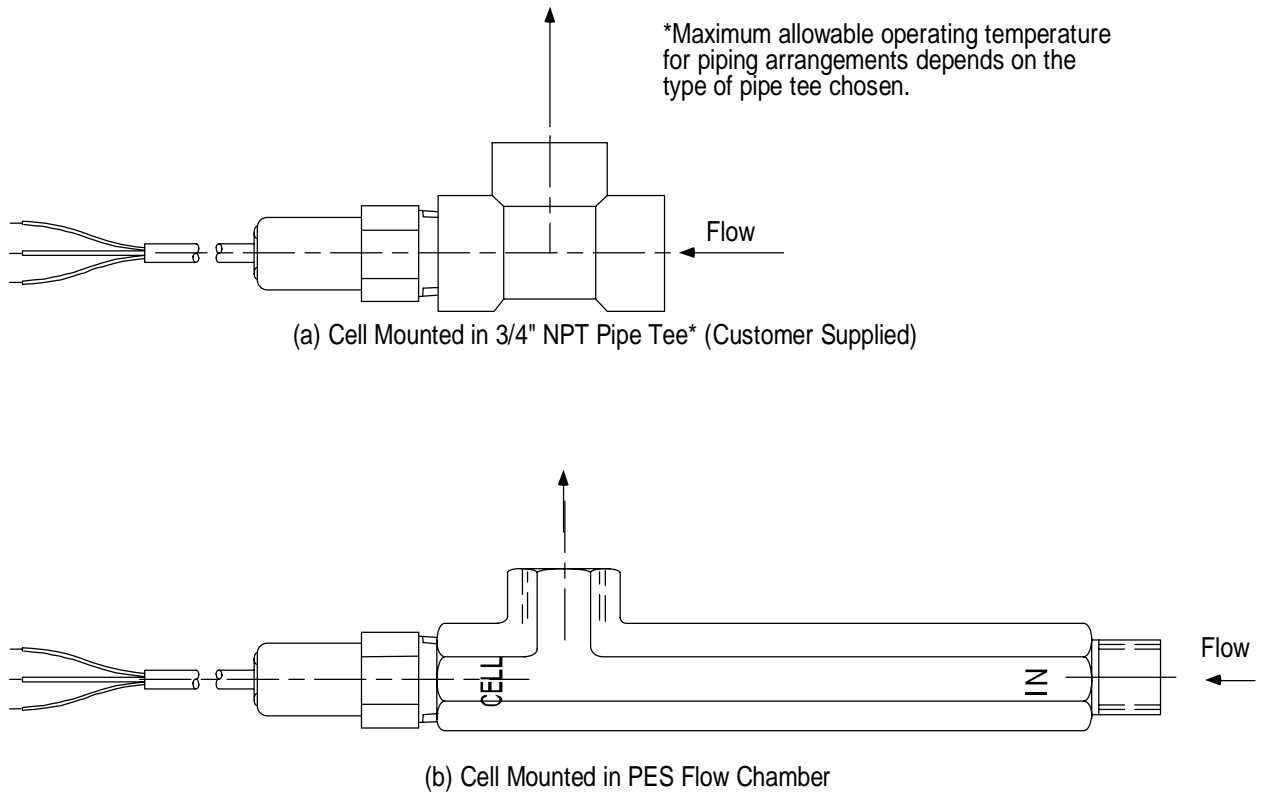

a/n 23341

Figure 1-3 Two Piping Arrangements for the Cell

2. Specifications

2.1 Specifications for 04973 Series

Parameter	Description
Cell Constant	04973 Series: 0.01, 0.1, 1.0 and 10 as specified
Electrode Material	0.01 and 0.1 constant, titanium 1.0 and 10 constant, high density graphite with Teflon sheath
Maximum Pressure Limit	1724 kPa (250 psig) at rated temperature
Maximum Continuous Temperature Limit	140°C (284°F) at rated pressure For PVC wire: 105°C (221°F)
Materials of Construction	Cell Body: PES (polyethersulfone) Electrodes: see 'Electrode Material'
Cable Options	Leadwire: PVC insulated 18 gage cable 20 and 50 feet lengths available Quick Disconnect Option Universal Head (Aluminum)
Approvals	Manufactured to comply with ASME boiler and pressure vessel code Section III, Div.1, UG-101 CRN #0F11607.5C
Insertion	3/4" NPT male, Schedule 40 and 80 pipes
Insertion Depth	3-1/2" (89 mm) for 1, 10 and 0.01 cell constants from solution end of 3/4" MNPT 2-1/2" (64mm) for 0.1 cell constant

2.2 Specifications for 055919 Flow Chamber

Parameter	Description
Maximum Flow	2 gpm @ 40psig and atmospheric discharge
Maximum Pressure	200 psig @ 25°C
Maximum Temperature	140°C (284°F) at atmospheric pressure
Dimensions	See Figure 3-1
Materials of Construction	Polyethersulfone (PES)

3. Installation

3.1 General Requirements

Observe the following before installing a conductivity cell. Specific requirements for particular types of installation are given in Sections 3.3 and 3.4.

- Do not remove the Teflon sheath on 1 or 10 constant cells, as this will change the cell constant value.
- Do not use the cell in solutions which can affect the fittings or the cell materials. If in doubt, contact Honeywell.
- Avoid all chlorinated hydrocarbons.
Titanium and PES (0.01 and 0.1 cell constants) and Graphite, Teflon and PES (1.0 and 10 cell constants) are the only cell materials in contact with measured solutions. These materials are inert to corrosive chemicals such as mineral acids, oxidizing agents and caustic solutions.
- Avoid trapped air; see that air is not trapped in the cell flow channels.
- Do not use the cell in solutions having temperatures or pressures greater than the maximum limits stated in the Specifications.
- Avoid locations where the operator must take an awkward position to install or remove the cell.
- When tightening, do not exceed the torque limits provided in Section 3.5. Over-tightening can break the cell or severely stress it causing cracks to develop, leading to eventual malfunction.

3.2 The Differences between the Quick Disconnect and Integral Cable Option

The cable options of quick disconnect and integral cable do not affect the performance of the cell. These options only relate to how the cell is connected to the instrument.

ATTENTION

- The electrical connections are different for these options. Please refer to Section 4 for instructions.
- The wire colors for the integral cable and quick disconnect option are not the same.

- Integral cable means the cable is potted into the cell. The cable and cell are one entity and cannot be separated.
- The quick disconnect option means the cell is connected to the cell by a receptacle on the top of the cell. The cell and the cable are separate entities. When the time comes to replace the cell, the cable does not have to be replaced. The cable can simply be mated with another cell that has the quick disconnect option. This option can not be used in immersion applications.

ATTENTION

The quick disconnect cable can be purchased from Honeywell.

3.3 In-Line Type Mounting

In addition to the General Requirements outlined above, note the following with regard to insertion-type mounting:

- Make certain the liquid head is above the cell location during measurement. A vertical insertion (from above) or a horizontal insertion can be used.
- Allow at least one-half inch clearance beyond the end of the cell and 1/8 to 3/16 inch radius clearance to permit circulation of the solution.
- It is usually best to have the solution flow up into the end of the cell since it is less likely to result in clogging by solids settling in the cell channels.
- To be sure that a representative sample is being measured at all times, the solution must continuously move through the cell channels. In a rapidly moving solution, the assembly may be mounted so that the existing circulation forces the solution through the channels. When measurements are made in quiescent solutions, artificial means must be provided to force the solution through the cell. In some cases, this may be accomplished by moving the cell up and down.

Installation

Tighten the cell into a 3/4" NPT threaded opening (do not exceed a tightening torque greater than that indicated in Section 3.5) using a Teflon thread compound (preferably Teflon tape).

3.4 Flow-Type Mounting

In addition to the General Requirements outlined in Section 3.1, note the following with regard to flow-type mounting:

- When mounting the cell in a pipe tee or flow chamber such as shown in Figure 1-3, have the solution enter the tee from below and exit to the side or from side and exit top. Be sure the electrodes are always as far as possible below the horizontal pipe run so that they are always covered to insure flooding of the cell under all conditions; otherwise, the conductivity reading may indicate a value that is lower than expected.
- In general, the cell should be mounted so that the sample will flow through the channel toward the mounting end of the cell, exiting through the other channel hole or through the outer electrode holes. See Figure 1-1.
- Locate the cell on the pressure side, not the vacuum side, of pumps. See Figure 1-2.
- Avoid a horizontal cell mounting having the flow channel, see Figure 1-1, opposite to the flow exit of the pipe line, especially for the 1 and 10 constant cells. If necessary, refer to Section 5.5.
- The 3/4" tee arrangement, Figure 1-3, assures that the cell is immersed well into the flow stream to obtain a representative sample. The tee is not supplied.

Installation

1. Tighten the cell into a 3/4" pipe tee (do not exceed a tightening torque greater than that indicated in Section 3.5).
2. If the flow-cell housing is used, assemble the cell and housing and install it in the process flow line or in a bypass line as indicated in Figure 1-2.
3. To avoid cracking the 055919 flow chamber, use Teflon tape on cell threads and tighten cell only enough to prevent leakage.

3.5 Torque Recommendations

For inserting a cell in metal fittings or bushings - 40 ft-lb maximum. For inserting a cell in plastic fittings or bushings - 10 ft-lb maximum. Always use pipe sealant (preferably Teflon tape).

3.6 Dimension Drawings

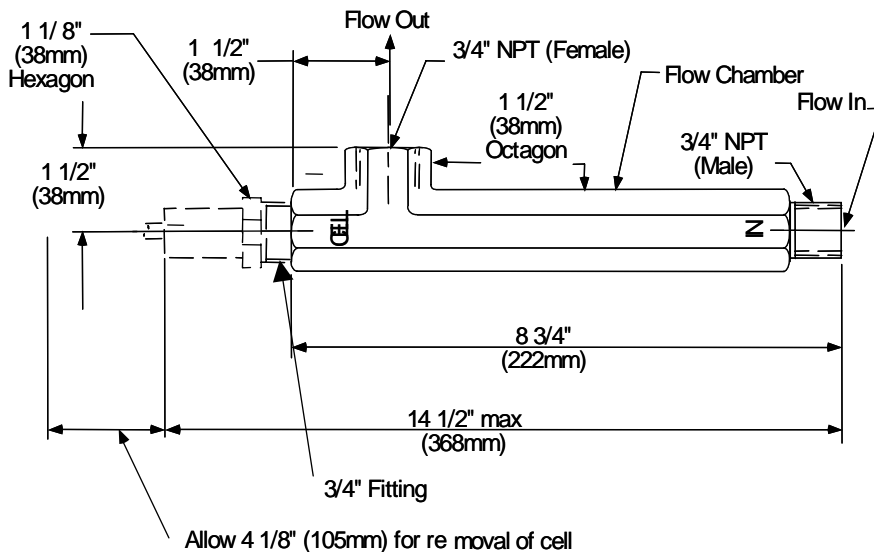

Notes:

1. Mount cell and flow chamber horizontally as shown above with flow exit up to eliminate possible air gap around cell body.
2. If cell and flow chamber must be mounted vertically, attach a short length of tubing to flow exit as shown below and form a trap to ensure filling of flow chamber, especially at low flow.

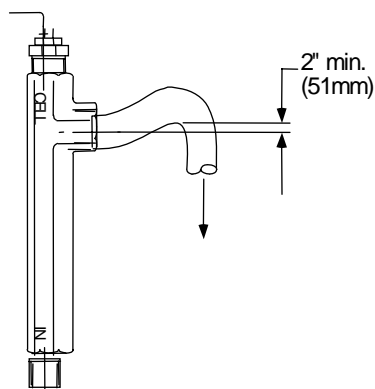

ah 23342

Figure 3-1 Dimension Drawing for 055919 Flow Chamber

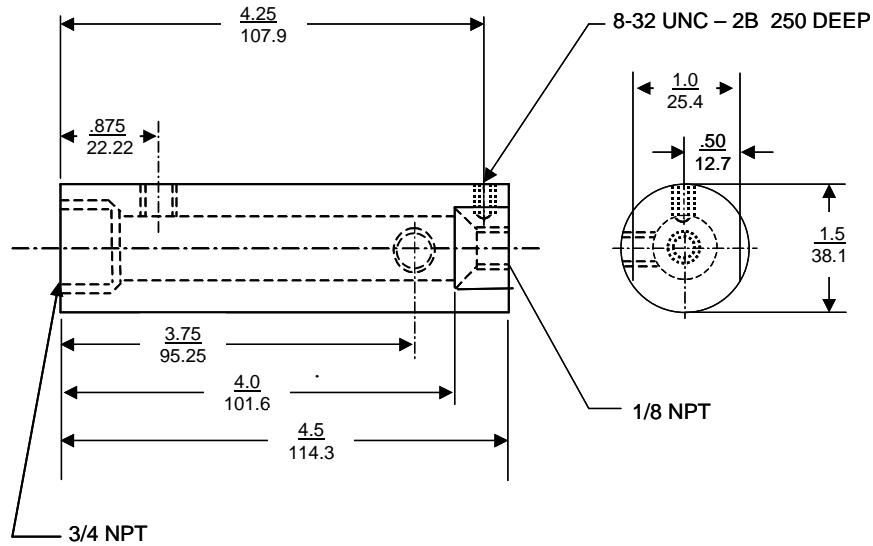
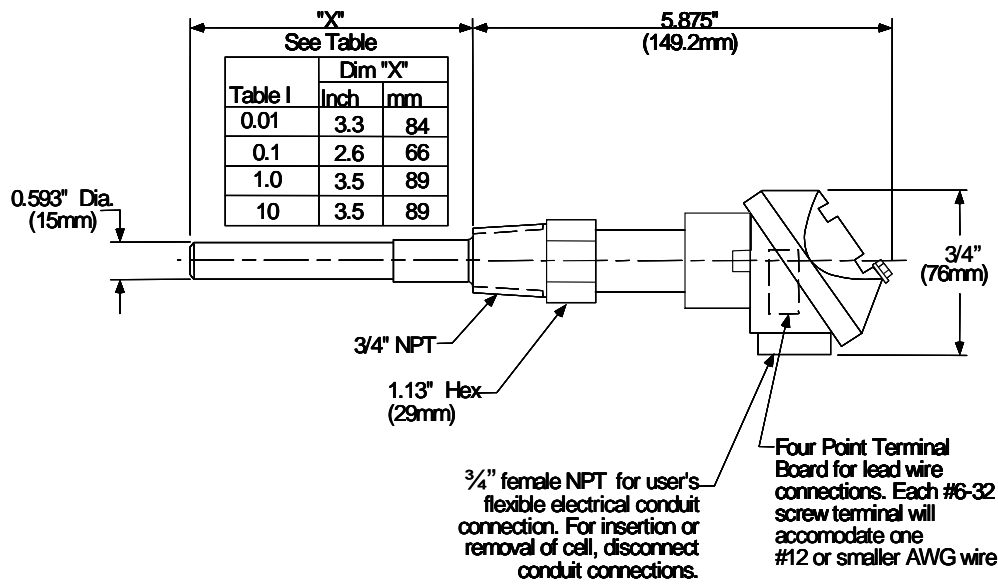
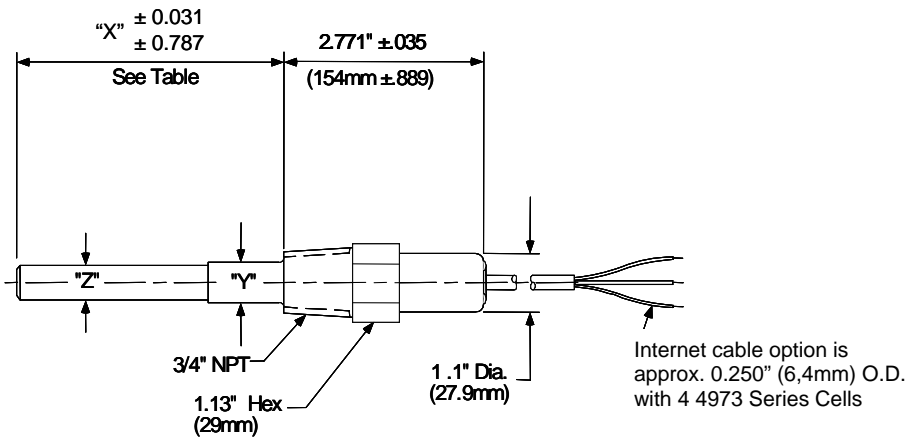

Figure 3-2 Dimension Drawing for 31079198 Flow Chamber



NOTE: For existing users with conduit, a 3/4" x 1/2" adapter bushing will be required to use existing conduit.

Figure 3-3 Outline and Dimensions for Conductivity Cell with Universal Head



Suffix A	Dim "X"		Dim "Y"		Dim "Z"	
	Inch	mm	Inch	mm	Inch	mm
0.01	3.3	84	.703	17.85	.542	13.76
0.1	2.6	66	.703	17.85	.542	13.76
1.0	3.5	89	.593	15.06	.625	15.87
10	3.5	89	.593	15.06	.564	14.32

Figure 3-4 Outline and Dimensions for Conductivity Cell with Integral Cable

4. Electrical Connections

4.1 Overview

The terminal board connections for the various Honeywell measuring instruments are given in the appropriate Figures in this section.

To avoid the possibility of AC pickup in the cell leads, separate them from all AC line-voltage wiring or run them in a separate grounded conduit.

ATTENTION

Do not use shielded cable except where shown in the following figures.

4.2 Instrument Wiring for 4973 Cells with Integral Cable

4.2.1 Model 4973 Series with Integral Cable to UDA2182 Analyzer

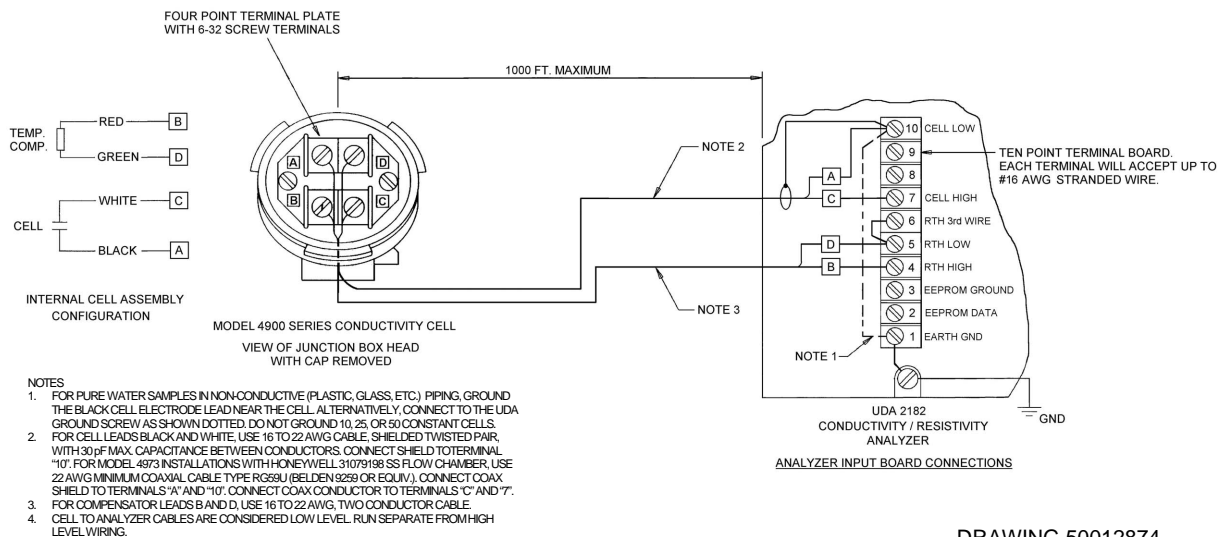

DRAWING 50012874

Figure 4-1 Installation Diagram, 4973 Cells, with junction box head connected to UDA2182 Analyzer

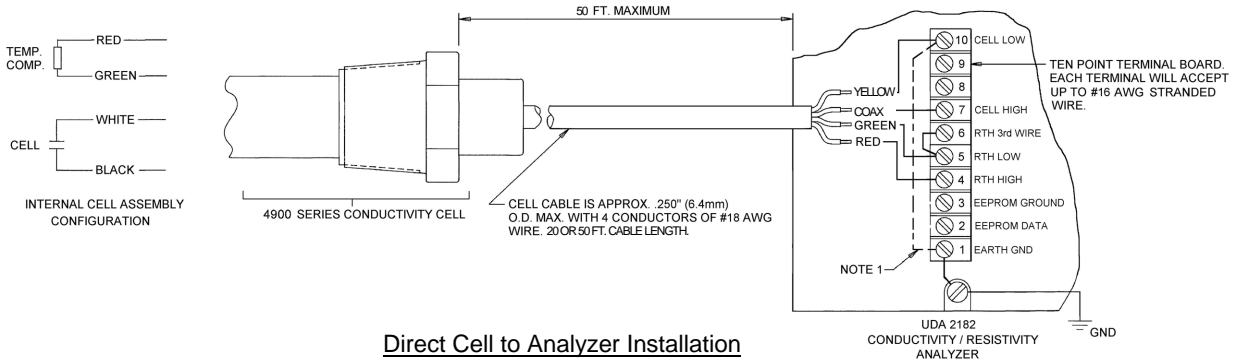

Direct Cell to Analyzer Installation

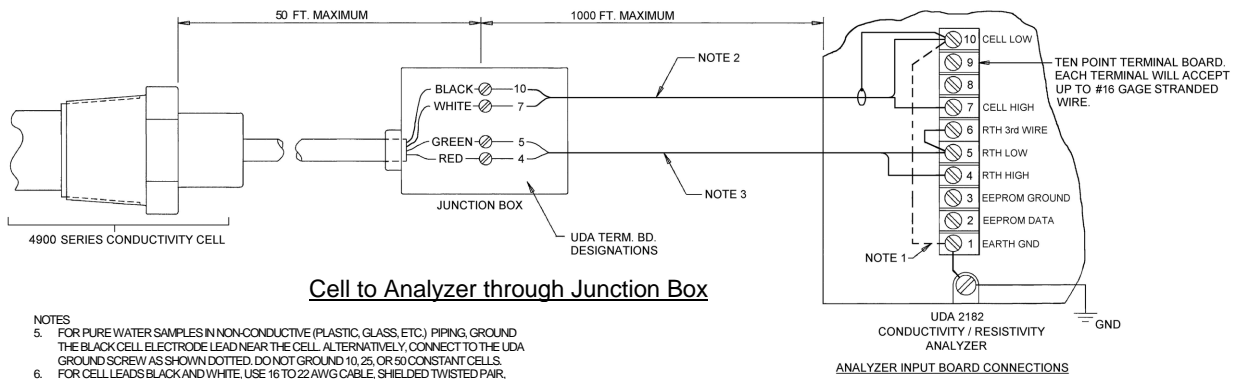

Cell to Analyzer through Junction Box

NOTES

5. FOR PURE WATER SAMPLES IN NON-CONDUCTIVE (PLASTIC, GLASS, ETC.) PIPING, GROUND THE BLACK CELL ELECTRODE LEAD NEAR THE CELL. ALTERNATIVELY, CONNECT TO THE UDA GROUND SCREW AS SHOWN DOTTED. DO NOT GROUND 10, 25, OR 50 CONSTANT CELLS.
6. FOR CELL LEADS BLACK AND WHITE, USE 16 TO 22 AWG CABLE, SHIELDED TWISTED PAIR, WITH 30 pF MAX. CAPACITANCE BETWEEN CONDUCTORS. CONNECT SHIELD TO TERMINAL "10". FOR MODEL 4973 INSTALLATIONS WITH HONEYWELL 31079198 SS FLOW CHAMBER, USE 22 AWG MINIMUM COAXIAL CABLE TYPE RG59U (BELDEN 9259 OR EQUIV.). CONNECT COAX SHIELD FROM "BLACK" TO TERMINAL "10". CONNECT COAX CONDUCTOR FROM "WHITE" TO TERMINAL "7".
7. FOR COMPENSATOR LEADS RED AND GREEN, USE 16 TO 22 AWG, TWO CONDUCTOR CABLE.
8. CELL TO ANALYZER CABLES ARE CONSIDERED LOW LEVEL. RUN SEPARATE FROM HIGH LEVEL WIRING.

DRAWING 50012875

Figure 4-2 Installation Diagram, 4973 Cells, with Integral Cable Leads Directly Connected to UDA2182 Analyzer or Connected to Junction Box

4.2.2 Model 4973 Series with Integral Cable to APT Series Analyzer/Transmitter

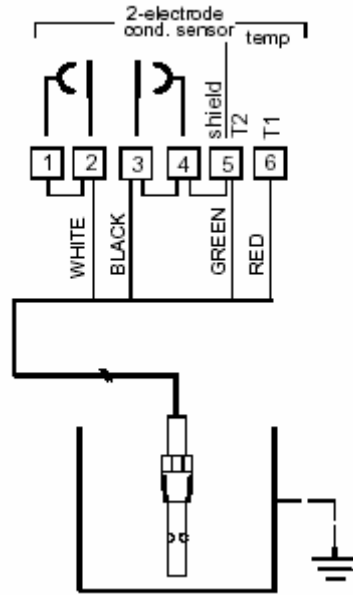

04973 series cells with integral cable leads connected to an APT4000

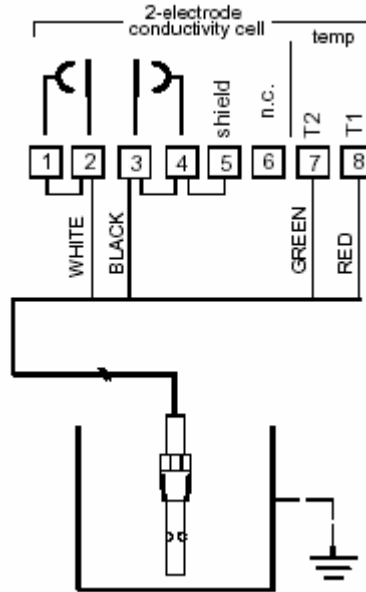

04973 series cells with integral cable leads connected to an APT2000

Figure 4-3 Model 4973 Series to APT Series Analyzer/Transmitter

4.3 Instrument Wiring for 4973 Cells with Quick Disconnect Cable

4.3.1 Wiring Model 4973 with Quick Disconnect Cable to UDA2182

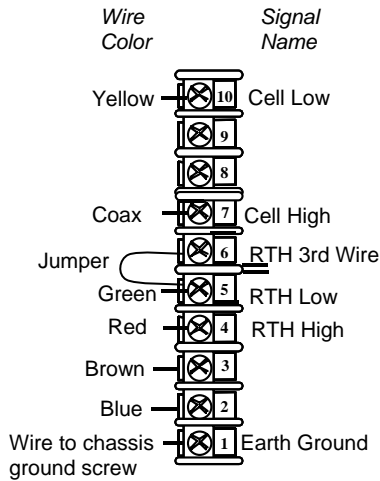

Figure 4-4 Wiring Diagram for 4973 Cells with Quick Disconnect Cable Connected to UDA2182 Analyzer

4.3.2 Wiring Model 4973 with Quick Disconnect Cable to Junction Box

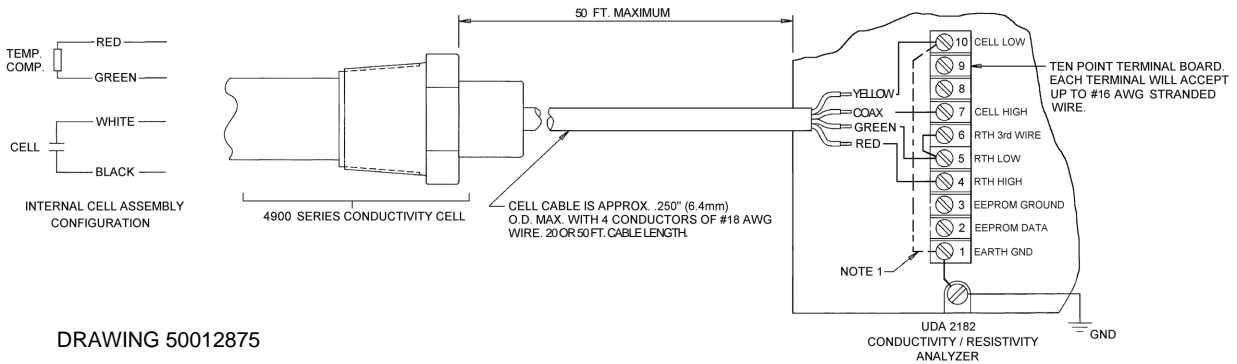

Figure 4-5 Installation diagram for 4973 cells with Quick Disconnect Cable connected to junction box

4.3.3 Wiring Model 4973 with Quick Disconnect Cable to APT

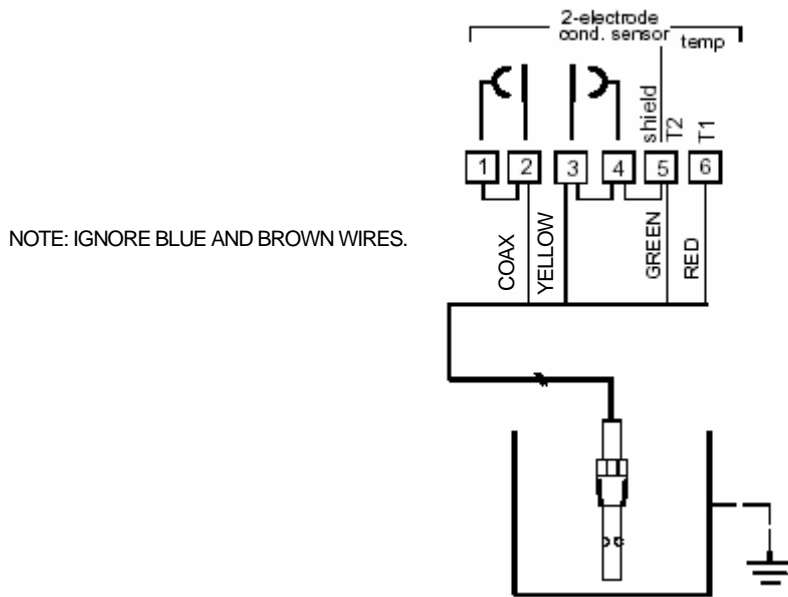

Figure 4-6 Wiring Diagram for 4973 Cells with Quick Disconnect Cable Connected to APT4000

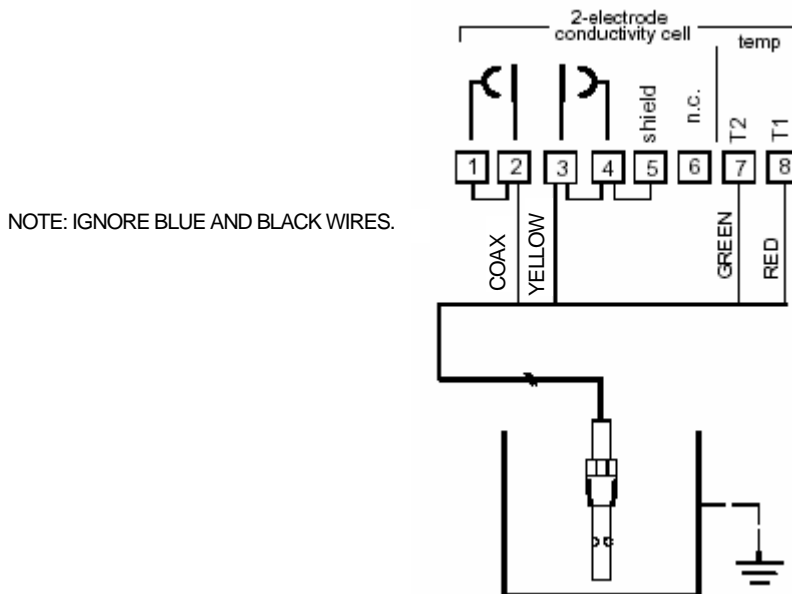

Figure 4-7 Wiring Diagram for 4973 Cells with Quick Disconnect Cable Connected to APT2000

5. Maintenance

5.1 Overview

The only maintenance that may be required is occasional cleaning. When cleaning, avoid scratching electrode surfaces. Do not use a brush or pipe cleaner.

5.2 To Clean the Cell

The cell will require cleaning if sludge, slime, etc., accumulate in the flow channels. Since the materials of construction are chemically inert, chemical agents may be used and are recommended for cleaning the cells. The particular cleaning agent used must be selected according to the type of contamination to which the cell is exposed.

The cell housing is made of a polyethersulfone, PES, and must not be cleaned with acetone, chloroform, toluene, benzene, or other chlorinated hydrocarbons.

In general, a "quick" rinse in a 10% inorganic acid is effective and often adequate. Another method is to use a strong stream of water to dislodge particles; then reverse flush. After cleaning, rinse the cell thoroughly in tap water and then distilled water, if available. Take care not to scratch electrode surfaces.

5.3 Check Conductivity System

To check the conductivity system comprising the conductivity cell, leadwires, and measuring instrument, make a measurement in a reference solution of known conductivity. Alternatively, use a second cell having the same constant and temperature compensation and compare the two readings. Be sure the cells are not touching the bottom or sides of the container for this test.

If Table II of the conductivity cell model number is 333, the normal resistance of the temperature sensor as measured across the red (B) and green (D) leads is 8550 ohms at 25 C.

To check the electrode insulation, connect an ohmmeter across the black (A) and white (C) leads. With a dry and clean cell, the resistance should be greater than 50 megaohms.

5.4 Troubleshooting

A series of below normal conductivity readings could indicate that the cell is not filled with solution resulting in a lack of response.

If the plastic surface of the cell has a grayish dull appearance instead of its normal glassy appearance, the cell has been exposed to temperature above its specified maximum. Check the solution temperature and replace the conductivity cell.

5.5 Air Entrapped in Cell Flow Channel

If measurement errors appear for horizontal mountings of a 1 or 10 constant cell, it may be that air is entrapped in the cell flow channel. Take one of the following actions to eliminate this problem:

- Increase flow to at least 1 gpm.
- Rotate the cell mounting so that its flow channel faces the same direction as the pipeline flow exit.
- Install the cell and/or flow chamber vertically.

6. Accessories and Spare Parts

Description	Part Number
Flow Cell Housing (PES)	055919
Flow Cell Housing (316 SS)	31079198
Junction Box	31316260
Teflon Shield	
White for 1 const. cell	31021599
Clear for 10 const. cell (see note below)	31018760
Extension Cables for Sensors with Quick Disconnect Option	
2 m (6.56 ft.)	50024092-001
3 m (9.84 ft.)	50024092-002
6 m (19.69 ft.)	50024092-003
15 m (49.21 ft.)	50024092-004
Extension Cable must be purchased from Honeywell	
Cell Extension Leadwire	
For ATC value of 333: Standard Range 9782 or 7082, also APT 2000 To 500 ft.: 3-conductor, 18 gage cable (Belden 9493) and Coax cable (Belden 9259) To 1000 ft.: Coax cable (Belden 9259) Wide Range 9782 and 7082 To 500 ft.: 4-conductor, 18 gage cable only To 1000 ft.: 4-conductor (3 used), 16 gage only	834059 835024 835024 31834052 834055
For all cells with an ATC other than 333: 3-conductor, 18 gage cable (Belden 9493) only	834059

Note: For 10 constant cell, heat shrink the clear shield onto the cell using a 300°F max. temp.
(Cal Factor may change)

Honeywell

Honeywell Field Solutions
512 Virginia Drive
Fort Washington, PA 19034

70-82-25-17 10 07 Printed in USA

<http://hpsweb.honeywell.com>

Free Manuals Download Website

<http://myh66.com>

<http://usermanuals.us>

<http://www.somanuals.com>

<http://www.4manuals.cc>

<http://www.manual-lib.com>

<http://www.404manual.com>

<http://www.luxmanual.com>

<http://aubethermostatmanual.com>

Golf course search by state

<http://golfingnear.com>

Email search by domain

<http://emailbydomain.com>

Auto manuals search

<http://auto.somanuals.com>

TV manuals search

<http://tv.somanuals.com>