

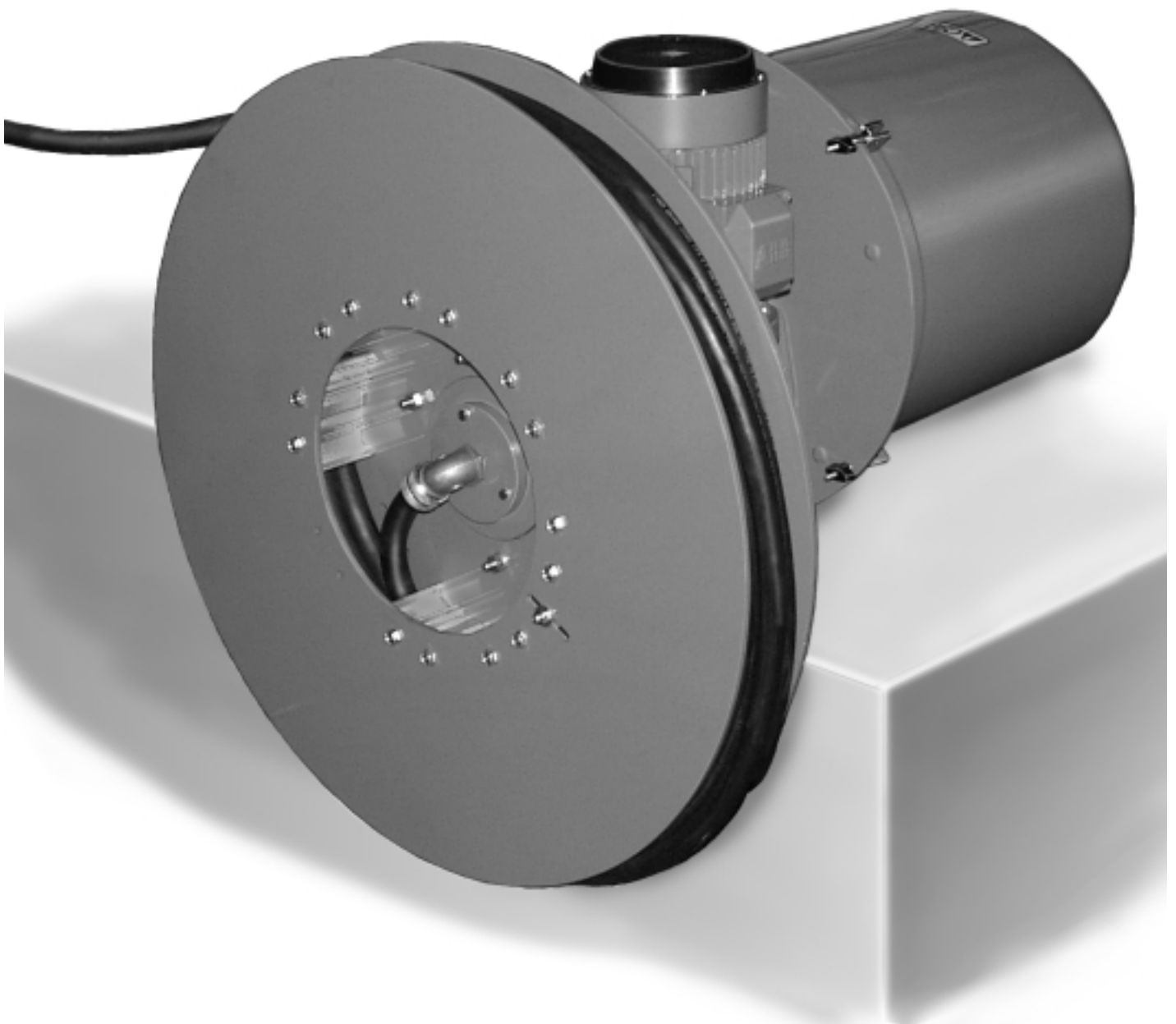

Maintenance Instructions

MRH Motor Reel



Wiring

Motor can be wired for either 230 volt or 460 volt, 3 phase, 60 hz A.C.
Follow jumper diagrams below.

NOTE:

Wiring should be done only by qualified, licensed electrician. Failure to follow standard safety precautions could lead to serious injury.

BLK	V2	⊕	⊕	W1	BRN
GRN	U2	⊕	⊕	V1	YLW
BLU	W2	⊕	⊕	U1	RED

View inside Motor Junction Box

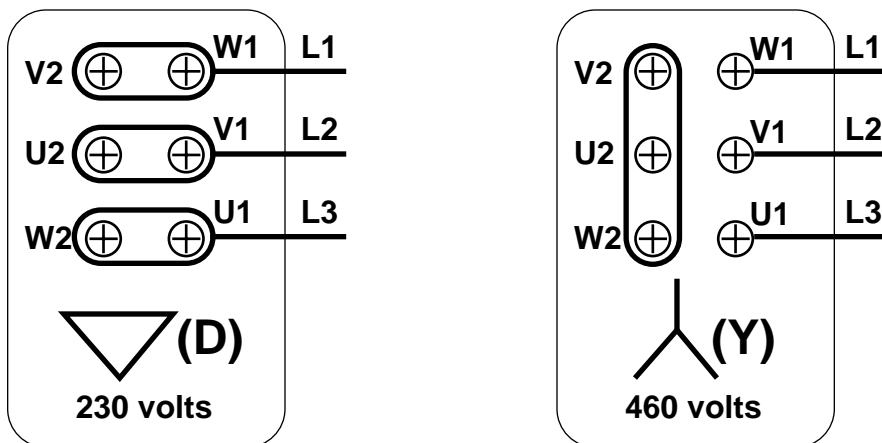

Jumpering Diagrams

- The cable reel motor must be energized during reeling in of the cable (machine travelling toward the feed point). During paying out (machine travelling away from feed point) and at stand still, the reel motor must not be energized. When paying out, the release of the cable is obtained through the controlled slippage of the hydrodynamic clutch inside the torque unit.
- The timer D (delayed opening 2-3 sec.) delays the disconnection of the cable reel motor with respect to the crane advance motors in order to ensure proper cable tension.

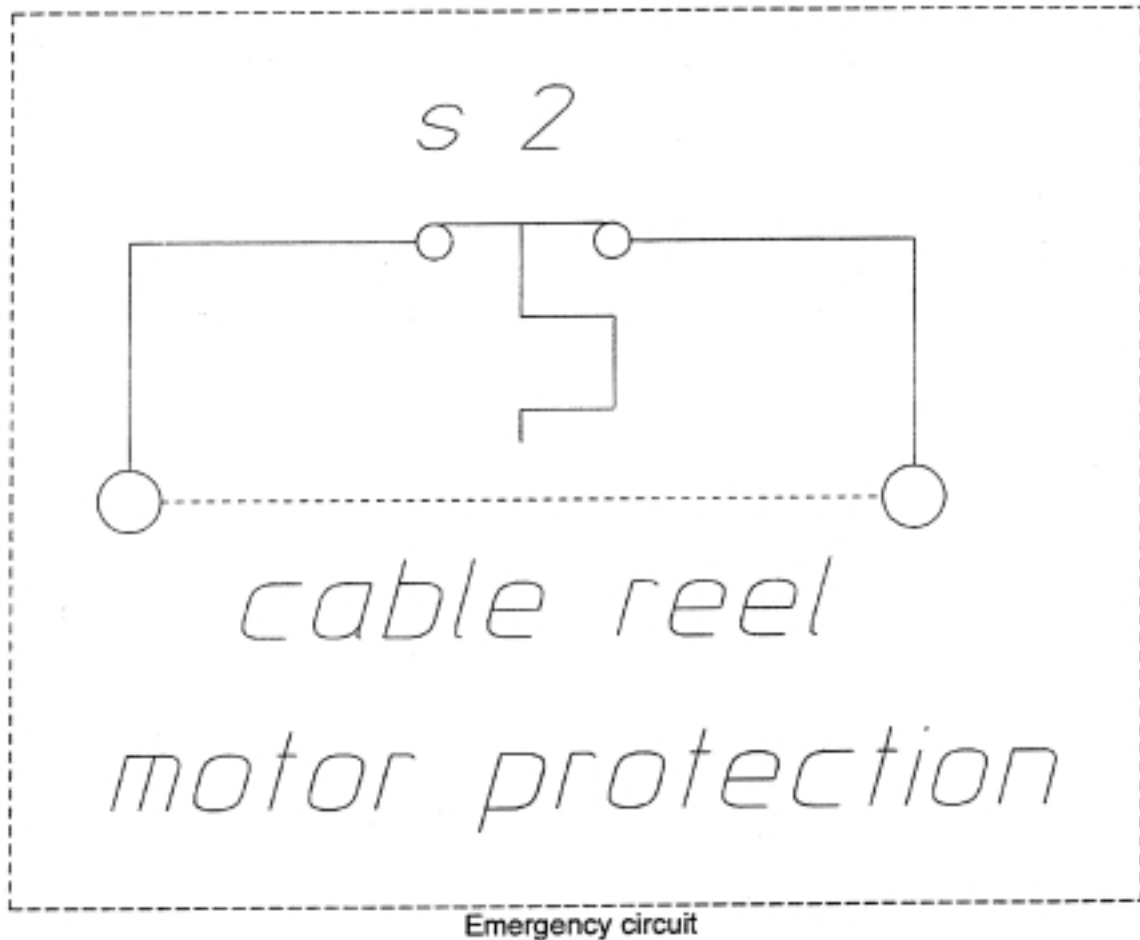

- **WARNING!** Emergency circuit contacts cannot be delayed for any reason.

TORQUE OUTPUT REGULATION

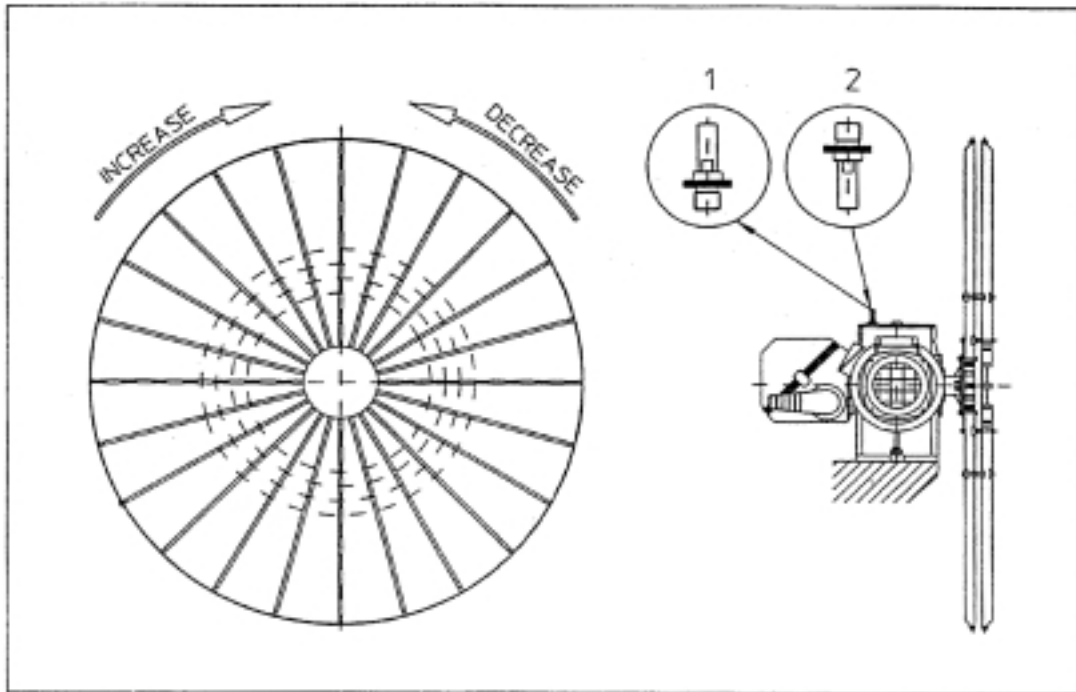

Figure 1

1. Unscrew torque regulating key (see drawing).
2. Turn key upside down and replace it into torque unit.
3. Turn drum slowly until key enters completely in the hole into locked position.
4. Turn drum clockwise to increase torque; turn drum counter-clockwise to decrease torque. (cable reel seen from the drum side).

Adjust torque by turning the drum a quarter to half a turn at a time. The torque must be sufficient to recover the cable at full drum but should not exert too much pull on the cable when drum is empty.

On completion, remove regulating key and replace it the correct way round.

WARNING!

The regulation has no safety limitation. Over torque settings may damage the worm screw and crown gear and cause internal vibrations.

Driving a crane with torque setting key locked (inserted position 2) will damage the gearbox.

NOTE! At delivery the torque output is pre-set at 75% (for units 10.0-20.0-40.0) of the nominal torque value of the unit.

It might therefore be necessary to adjust the output on site at start-up accordingly to the specific torque requirement of each application.

For the 120.0 unit the torque output is pre-set at the theoretical torque value for the application. Field adjustment is always required.

Torque unit	10.0	20.0	40.0	120.0
Drums turns min. to max. torque settings	1.5	1.5	2.5	3

HOW TORQUE UNIT WORKS

Gleason series MRH reels feature torque units which work on a patented self braking hydrodynamic clutch system.

The Functions of the torque unit are:

- To provide a constant torque on the drum shaft.
- To gear the drum rotating speed to the reeling diameter of the cable.
- To brake the drum when stationary.
- To allow a controlled unreeling of the cable.
- To regulate the torque output according to the requirements of each application.

The torque unit is powered by a motor rotating at a constant speed. Normally a conventional electric squirrel cage motor is used but the unit can also be powered by an air or a hydraulic motor.

The torque of the driving motor is transmitted to the drum shaft through a hydrodynamic clutch which is combined with a worm gear reduction. The output torque is only minimally affected by the rotating speed of the input and output shafts. The output torque can be set from zero to maximum torque through a spring arrangement in the clutch.

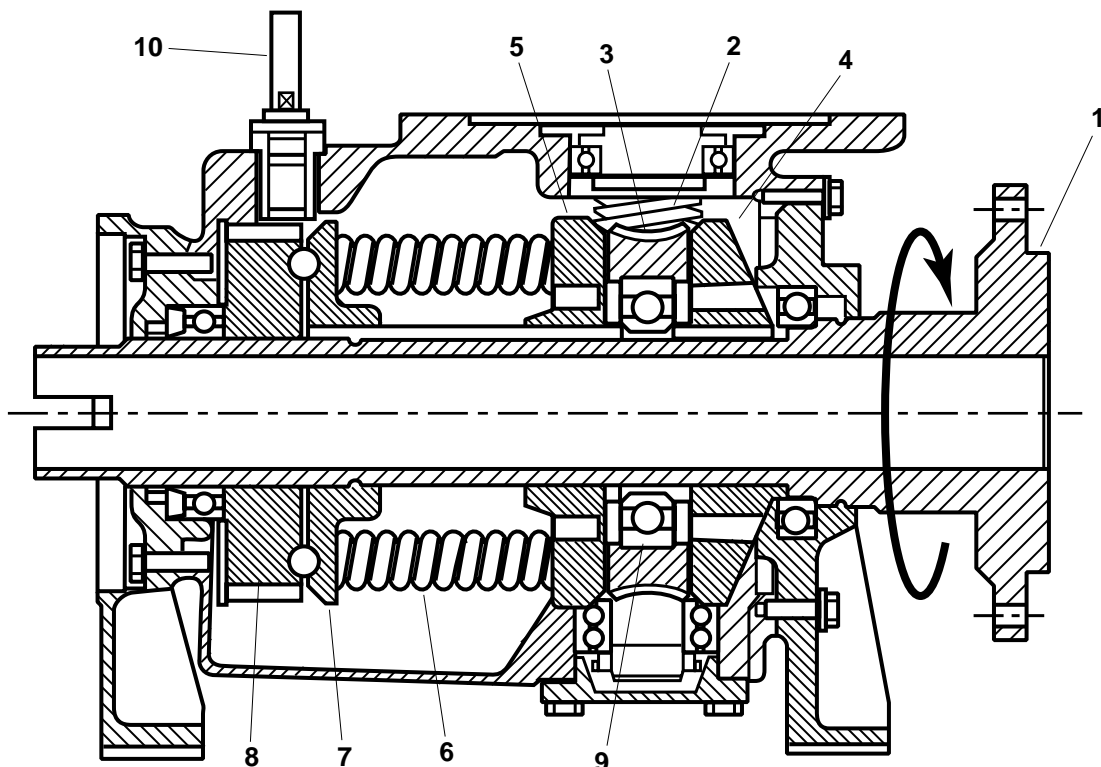

Section View of Torque Unit

Following is a brief description of the torque unit components:

(Please refer to drawing on page 5)

The bronze crown gear (item 3) has specially machined surfaces on both sides. Freely mounted on the drum shaft (item 1), the crown gear is linked to the motor via a worm gear (item 2).

There are two friction plates (items 4 & 5), one on each side of the crown gear. They are made of steel and are fixed to the drum shaft with keys. The friction plates are also specially machined so that an oil film is created between the plates and the crown gear. The oil film allows slippage as torque is transferred from the crown gear to the friction plates. Pulling force on the cable remains constant, even with the motor running at a constant speed, and is fully adjustable.

The special machining on the clutch surfaces assures that they remain lubricated, even when clutch is not moving, eliminating the normally occurring "stick-slip" effect. Variation between dynamic and static friction remains within 3-10% depending on size of the torque unit.

Since the worm gear is irreversible, the clutch also acts as a brake when the motor is off. This provides two major advantages:

- A) Electro-magnetic brake, required on conventional cable reels, is not needed.
- B) Braking torque is the same as reeling torque, avoiding uneven pulling force on the cable when the motor is switched on and off.

The torque unit has an adjustable spring assembly to vary the pressure on the clutch and obtain the required output. The spring assembly consists of the rear friction plate (item 5), compressions springs (item 6), the spring holder plate (item 7) and the torque regulating nut (item 8).

The springs are placed between the rear friction plate and the spring holder which is fixed onto the drum shaft with a key, allowing it to slide along the shaft. The torque regulating nut is screwed onto the drum shaft and pushes against the spring holder plate through a series of steel ball bearings.

Torque can be regulated by placing the torque regulating key (item 10) upside down into the torque unit, preventing the regulating nut from rotating. With the regulating nut held in position, the drum can be turned manually or with the help of the cable reel motor to increase or decrease the pressure on the spring assembly thereby increasing or decreasing the torque output of the clutch. Refer to "TORQUE OUTPUT REGULATION", page 4, for details.

MAINTENANCE INSTRUCTIONS

Gleason cable and hose reels are designed so that maintenance is reduced to a minimum. However, in order to guarantee a correct and continuous function of the reel, it is necessary to follow a few simple rules, hereafter described.

AFTER FIRST OPERATING WEEK:

Drum

- Verify the tightening of all bolts and nuts including the ones fixing the torque unit onto its support, the collector, the drum and the motor to the torque unit.
- In case that the drum is of a monospiral type check that the spacing between the wheels at the inner ring is cable diameter + 10% (max. 4mm) and at the outer diameter corresponds to cable diameter + 2-3 mm.

Collector (if any)

- Verify tightening of all electrical connections and check ring - brush alignment. All carbon brushes must be in the grooves of the rings.
Note! Always switch current off before removing collector cover.

AT REGULAR INTERVALS (TWO MONTHS):

The frequency of these regular checks will also depend on the severity of the environment in which the reel is working and on the duty cycle intensity.

Collector (if any)

- Verify tightening of all electrical connections and check ring - brush alignment. All carbon brushes must be in the grooves of the rings.

Note! Always switch current off before removing collector cover.

- If necessary clean collector inside noting the following:
 - a) Never use water when cleaning. Use vacuum cleaner, brush or lint-free cloth.
 - b) Sliprings must be dry, clean and free from oil or other covering stains.
 - c) If any part is found to be damaged it must be replaced as soon as possible with a new original spare part.
 - d) After cleaning the rings remount the collector housing ensuring that the drainage holes are downwards. Also make sure the rubber gasket is in place with its joint downwards as well. This will ensure a good sealing.

Rotary joint (if any)

- Change the gasket **only** if there are some dribbles. The ball bearings do not need any maintenance, since they normally are life-lubricated; on the contrary there will be special instructions about the lubrication.

Torque unit

- Check oil level through the level gauge, and, if necessary, top it up with the oil type specified further on.
- With the aid of a dynamometer check that the output torque has not changed since start-up due to the setting of mechanical components during run-in. The torque should be set so that the cable is pulled up evenly, without slackening or excessive tension.

Electric motor (if any)

- Keep the motor surface clean, in order to ensure a proper cooling. The ball bearings do not need any maintenance, since they are of the sealed type, life-lubricated.

Hydraulic motor (if any)

- Check fittings.

Drum

- Check regularly the gap between spokes: at the inner ring is cable diameter + 10% (max. 4mm) and at the outer diameter corresponds to cable diameter + 2-3 mm.

EVERY TWELVE MONTHS:

General

- Carry out all the operations described in the previous points.

Torque unit

- Change oil in the torque unit. The oil to be used for ambient temperatures between -15° and +38°C is Esso GX 85W-140. For ambient temperatures between -24°C and +38°C use oil Esso GX 80W-90.

For higher or lower temperatures please contact the manufacturer or one of his representatives.

Note! When the reel is used for severe applications (i.e. vertical recovery or continuous operation) the oil should be changed about every 500 hours of work.

- Recheck the torque. If torque adjustment is needed decrease or increase the torque setting for a lower or higher torque requested by the single application.
- Limit switch (if any) : check cam positions and that switches are operating.
- Heaters (if any) : check that they are operating.

Torque Unit Oil Capacity

Torque Unit	Oil Capacity U.S. gal
10.0	.45
20.0	.58
40.0	4.24
120.0	7.16
200.0	17.76
300.0	17.76
550.0	25.97
700.0	25.97

TROUBLE SHOOTING THE HYDRODYNAMIC DRIVE

Below is a trouble shooting scheme for the hydrodynamic drive unit.

The main reason for failure of this unit is heat, heat is created because of:

FAILURE	CAUSE	ACTION
Motor not running	Fuses lines etc	Change if necessary.
	Motor starter in crane command	If burnt change
	Timer relay in crane command (used to switch off the cable reel motor with slight delay)	If burnt change
	Signal to cable reel motor starter from crane control	Cable reel motor should be on only when cable reel is to <u>reel in</u> cable Cable reel motor should be <u>off</u> when cable reel is to <u>reel out</u> cable Timer relay used to delay stop of cable reel motor when crane is stopped.
	Signal from cable guide pendulum - microswitch to sense left/right side of centre point of track	Only for centre feed applications, check signal and logic's to motor starter
	Crane command logic sensing microswitch on cable guide (see above) and crane travel direction	Only for centre feed applications, check that logic is correct and motor starter works when it should
	Motor burnt	Change motor
Motor running No torque	Torque not set in torque unit	Set torque see torque setting instructions When setting torque only turn drum 1/4 of a turn at a time and check result. Then, readjust if necessary. Maximum torque is needed when drum is nearly full (horizontal travel application) Check functions in this area. Do not set torque higher than necessary.

FAILURE	CAUSE	SOLUTION
Motor running No torque		Too much torque will only result in: <ul style="list-style-type: none"> • higher stress on cable than necessary • more heat in gearbox than necessary • you paying for energy lost in heat
	Check that motor key is in place on the motor shaft	Mount motor with key in shaft Check that the key does not slide up when motor is put in place
Motor running too little torque	Torque not set	Set torque
	Oil damaged	Change oil When oil gets burnt or damaged the result can be a loss in output torque. Change only to specified oil type
	Torque unit	Disassemble and check friction plates.
	Excessive cable length and/or weight	Check design data
	Torque unit friction plates worm out	Replace worm out parts.
Reel working vibrations or sounds when reeling out	Check oil	Change oil If oil is not correct type or there is water in the oil vibrations can easily happen. Type should be ESSO GX 85W140 or ESSO GX 80W90 for low ambient temperature applications. No similar oils from other manufacturers are recommended. If unit is set to a very high torque this phenomena can occur during running in when the crane is moving slowly (reel rotating) Consult with Gleason for a possible solution.
Cable drops when standing No braking effect	Check torque unit	This will normally happen if unit has been overheated and the oil has been burnt. Teeth on crown gear not existing anymore.

FAILURE	CAUSE	ACTION
Cable drops when standing No braking effect	Check torque unit	Two alternatives are: 1. Unit is heavily overloaded or motor has run 100%. This problem will appear within short time days to week. 2. Unit is slightly overloaded or unit is working very intensively and oil has not been changed at regular intervals. Oil will degenerate a little by little until the total volume of oil is destroyed the crown gear will wear out. Units with very high working intensity should have their oil changed every 3 months.
	Check motor	If motor is not running when cable reel is to reel in crane with trip. Check signal from crane to motor starter. Check logic so motor is running when crane moves to center point (against cable) Check that motor starts again after inverting direction without stopping. (Joy-Stick full speed left to full speed right) Check that motor starts again after inverting direction with a stop in-between (brakes applied)
	Check motor	Check that motor is not always on. Motor should be on <u>only</u> when reeling in. Check motor delay off timer. If delay is too long or timer is not working gearbox will overheat. Correct timer setting is approx. 5 sec.
Reel pulling too hard	Lower torque	Set torque level.
Crane tripped when reeling in	Slack cable switch in cable guide	Check that signal is correct and that signal is not too early. A movement of the pendulum must be accepted, signal should come slightly before pendulum reaches its vertical position.

FAILURE	CAUSE	ACTION
Crane trippes when reeling in	Slack cable switch in cable guide	NOTE: The signal should break the crane emergency in a definitive way. Resetting must be done manually after that the reason for the slack cable has been determined and the cable stretched manually so that the pendulum is reset to its normal working position. Resetting may <u>not</u> be done by the driver from the driver cabin.
	Torque set too low	Set torque See torque setting instructions (see notes under motor running no torque)
Crane trippes when reeling out or cable drops when reeling out	Motor should not run	If motor is running backwards stop motor. Motor should always run only in one direction -the reeling in direction When reeling out or standing still motor should stopped.
Cable drops slowly when standing still - Motor not on	Torque unit reversible due to crane vibrations	Mount brake motor or Mount anti return unit on motor fan.
Cable reel trippes when reeling out - overtension	Overtension switch	Set switch to less sensitive position or Set torque lower
Collector : defective or discontinuous conduction	Incorrect wiring cable	Rewiring
Collector: short circuit	<ul style="list-style-type: none"> • overvoltage • humidity • defective cable • contact between more cables 	Replace collector
Incorrect cable position	Cable guide roller blocked	Replace roller
	Misalignment of the cable guide	Correct the alignment of cable guide with the cable
Sheathing cable damaged	Heavy machine cut it	Repair cable or replace
	Other causes	Control all cable guide rollers and replace if necessary Check pull force and regulate it Check the feed pit



Gleason Reel Corp.

600 South Clark St. • P.O Box 26

Mayville, WI 53050

920-387-4120

www.hubbell-gleason.com

Free Manuals Download Website

<http://myh66.com>

<http://usermanuals.us>

<http://www.somanuals.com>

<http://www.4manuals.cc>

<http://www.manual-lib.com>

<http://www.404manual.com>

<http://www.luxmanual.com>

<http://aubethermostatmanual.com>

Golf course search by state

<http://golfingnear.com>

Email search by domain

<http://emailbydomain.com>

Auto manuals search

<http://auto.somanuals.com>

TV manuals search

<http://tv.somanuals.com>